

## WhisperFit® EZ™ Ventilation Fans and Fan/Lights



### WhisperFit® EZ™ VENTILATION FAN

FV-08-11VF5  
FV-08-11VFM5  
FV-08-11VFL5E (with 3" duct adapter)



- Ideal for remodeling and hotel new construction or renovation
- Pick-A-Flow™ Airflow Selector – one fan, you choose the CFM (80 or 110)
- Single-hinged Flex-Z Fast™ bracket provides flexible, fast and easy installation
- Low profile housing design fits in 2 x 6 construction
- 4" duct with 3" duct adapter included
- New! Lighted model incorporates one 10W dimmable LED chip panel with <1W LED night light for warm, long-life energy efficient illumination (night light must be wired separately)
- Fan model FV-08-11VFM5 incorporates a SmartAction® Motion Sensor
- Engineered to comply with upcoming ENERGY STAR® requirements for increased efficiency (CFM/Watt)
- Can be used to comply with ASHRAE 62.2, LEED, IAP, California Title 24 and WA Ventilation Code

#### ADDITIONAL BENEFITS

- Slide and snap-in junction box and duct collar provide even greater installation flexibility
- Built-in metal flange provides blocking for penetrations through drywall as an Air Barrier, and assists with the decrease in leakage in the Building Envelope during blower door testing
- UL listed for tub/shower enclosure when GFCI protected
- Lighted model features 70 Lumens Per Watt (LPW), the highest LPW in the industry
- 3-year warranty on parts, 5 year on LED chip panel



## The ideal retrofit solution, premium low profile design and ultra-quiet performance

WhisperFit® EZ™ is the perfect solution for any remodeler looking to quickly and easily replace an existing fan from below the ceiling. This fan enables you to utilize existing duct, while its low profile housing design ensures a proper fit in any ceiling. The single-hinged Flex-Z Fast™ bracket provides flexible, fast and easy installation for easy positioning through a ceiling cavity. The slide and snap-in junction box and duct collar provide greater flexibility when wiring and attaching the duct. Once installed, use the Pick-A-Flow™ airflow selector to customize the airflow to meet your customers' needs. All of these great features combined make WhisperFit® EZ™ the fastest, easiest, ENERGY STAR® retrofit fan available.

### With WhisperFit® EZ™, installation is as **Easy as 1-2-3!**

**Step 1:** Single-Hinged Flex-Z Fast™ bracket installed with existing 3" duct and wiring



Single-Hinged Flex-Z Fast™ Installation Bracket

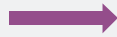

Existing 3" Duct and wiring

**Step 2:** Fan can be installed with motor in a 2 x 6 joist using the existing duct and included 4" to 3" duct adapter



**Step 3:** Fan is installed and ready to go!



## Powerful Performance and Quiet Operation at 0.25" Static Pressure

ASHRAE, ENERGY STAR®, LEED for Homes, and HVI have set the industry standard for performance measurement at 0.25" WhisperFit® EZ™ fans not only provide powerful CFM output at 0.25", but our soles have also been certified at 0.25", so they are quiet under pressure and after installation.



Specifications		WhisperFit® EZ™															
		FV-08-11VF5								FV-08-11VFM5							
		4"		3"		4"		3"		4"		3"		4"		3"	
Characteristics (HVI tested data for 0.1" S.P.)	Static Pressure in inches w.g.	0.1	0.25	0.1	0.25	0.1	0.25	0.1	0.25	0.1	0.25	0.1	0.25	0.1	0.25	0.1	0.25
	Air Volume (CFM)	110	104	100	85	80	73	70	61	110	102	100	88	80	71	70	59
	Noise (sones)	0.8	1.2	1.3	1.5	0.3	0.6	0.5	1.1	0.8	1.2	1.3	1.5	0.3	0.8	0.5	1.1
	Power Consumption (watts)	26.5	26.4	26.4	25.9	21.1	20.7	20.9	20.3	27.0	26.8	26.8	26.3	21.6	21.1	21.4	20.8
	Energy Efficiency (CFM/Watt)	4.2	4.0	3.9	3.5	3.8	3.5	3.5	3.2	4.1	3.8	3.8	3.3	3.7	3.3	3.5	3.0
	Speed (RPM)	961	1179	1215	1369	848	1123	1005	1236	955	1174	1197	1352	847	1131	1008	1229
	Amps (Current)	0.23	0.23	0.22	0.22	0.18	0.17	0.17	0.17	0.23	0.23	0.23	0.22	0.18	0.18	0.18	0.17
	MAX. Amps (Current)	0.23				0.20				0.23				0.18			
	Power Rating (V/Hz)	120/60				120/60				120/60				120/60			
	Specifications	Motor Type	AC				AC				AC				AC		
Type of Motor Bearing		Ball				Ball				Ball				Ball			
Thermal Fuse Protection		Yes				Yes				Yes				Yes			
Blower Wheel Type		Sirocco				Sirocco				Sirocco				Sirocco			
ENERGY STAR Qualified*		Yes				Yes				Yes				Yes			
Installation	Duct Diameter (inches)	4		3		4		3		4		3		4		3	
	Mounting Opening (inches sq.)	10-1/2				10-1/2				10-1/2				10-1/2			
	Grille Size (inches sq.)	13				13				13				13			
Light Specifications	Lamp Watts	N/A				N/A				N/A				N/A			
	Lumens (lm)	N/A				N/A				N/A				N/A			
	Lumens Per Watt (LPW)	N/A				N/A				N/A				N/A			
	Color Rendering Index	N/A				N/A				N/A				N/A			
	Color Temperature (Kelvin)	N/A				N/A				N/A				N/A			
	Rated Life (hours)	N/A				N/A				N/A				N/A			
	Lamp Model #	N/A				N/A				N/A				N/A			
	Type of Lamp Socket	N/A				N/A				N/A				N/A			
Night Light Specs	Night Light Watts	N/A				N/A				N/A				N/A			
Shipping	Gross Weight (lbs)	11.2				11.2				11.2				11.2			
Approved Code/ Standard/Regulation	UL Tub/Shower Enclosure	Yes				Yes				Yes				Yes			
	Washington VIAQ Code	Yes				Yes				Yes				Yes			
	California Title 24 Compliant	Yes				Yes				Yes				Yes			
	Mfg in ISO 9001 Certified Facility	Yes				Yes				Yes				Yes			

As tested by an EPA recognized lab  
**NOTE: 0.25" =Powerful Performance**

**NEW**



## LED Lighting

Includes a 10 Watt dimmable LED chip panel/3000 Kelvin Warm White/90CRI/700 lumens/70 LPW/ENERGY STAR® 2.0 certified/JA-8 compliant for CA Title 24/50,000 hours rated average life / <1W LED night light.



**NEW!**

Specifications		WhisperFit® EZ™ (Fan/Light Model)							
		FV-08-11VFL5E							
		4"		3"		4"		3"	
Characteristics (HVI tested data for 0.1" S.P.)	Static Pressure in inches w.g.	0.1	0.25	0.1	0.25	0.1	0.25	0.1	0.25
	Air Volume (CFM)	110	102	100	86	80	72	70	60
	Noise (sones)	1.0	1.3	1.3	1.5	0.4	0.7	0.6	1.0
	Power Consumption (watts)	26.6	26.5	26.4	25.8	20.9	20.5	20.8	20.2
	Energy Efficiency (CFM/Watt)	4.2	3.9	3.9	3.4	3.8	3.5	3.7	3.2
	Speed (RPM)	1033	1240	1270	1399	905	1164	1065	1263
	Amps (Current)	0.23	0.22	0.22	0.22	0.17	0.17	0.17	0.17
	MAX. Amps (Current)	0.23				0.17			
	Power Rating (V/Hz)	120/60				120/60			
Specifications	Motor Type	AC				AC			
	Type of Motor Bearing	Ball				Ball			
	Thermal Fuse Protection	Yes				Yes			
	Blower Wheel Type	Sirocco				Sirocco			
	ENERGY STAR Qualified*	Yes				Yes			
Installation	Duct Diameter (inches)	3		4		3		4	
	Mounting Opening (inches sq.)	10-1/2				10-1/2			
	Grille Size (inches sq.)	13				13			
Light Specifications	Lamp Watts	10.0				10			
	Lumens (lm)	700				700			
	Lumens Per Watt (LPW)	70				70			
	Color Rendering Index	90				90			
	Color Temperature (Kelvin)	3,000				3,000			
	Rated Life (hours)	50,000				50,000			
	Lamp Model #	N/A				N/A			
Type of Lamp Socket	LED Chip				LED Chip				
Night Light Specs	Night Light Watts	0.2				0.2			
Shipping	Gross Weight (lbs)	5.7				5.7			
Approved Code/ Standard/Regulation	UL Tub/Shower Enclosure	Yes				Yes			
	Washington VIAQ Code	Yes				Yes			
	California Title 24 Compliant	Yes				Yes			
	Mfg in ISO 9001 Certified Facility	Yes				Yes			

As tested by an EPA recognized lab

**NOTE: 0.25" = Powerful Performance**



**FV-08-11VF5**

**FV-08-11VF5**

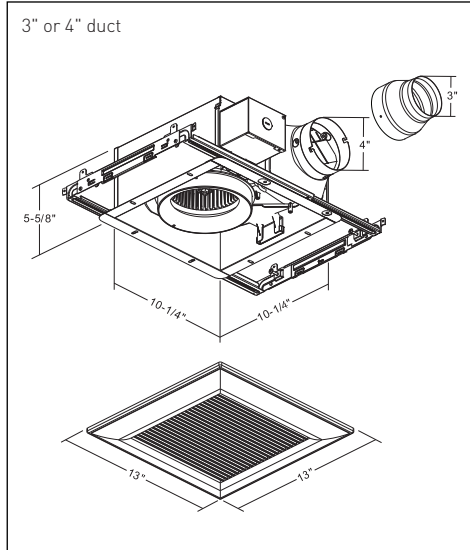

**FV-08-11VF5**

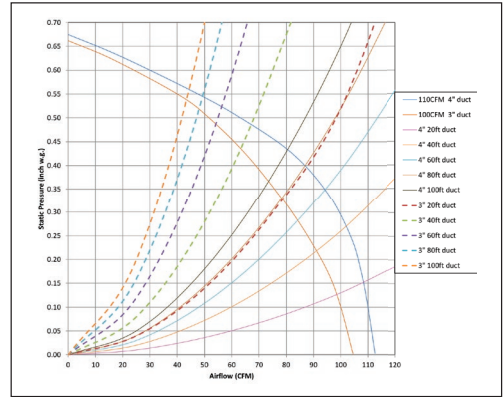

**FV-08-11VFM5**

**FV-08-11VFM5**

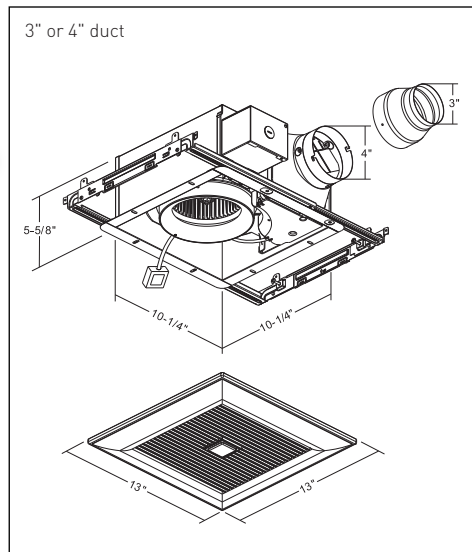

**FV-08-11VFM5**

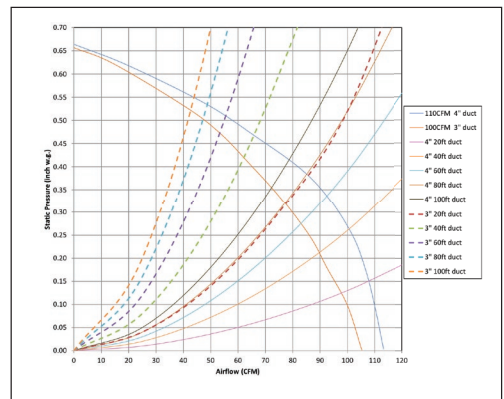

**FV-08-11VFL5E**  
(with 3" duct adapter)

**FV-08-11VFL5E**

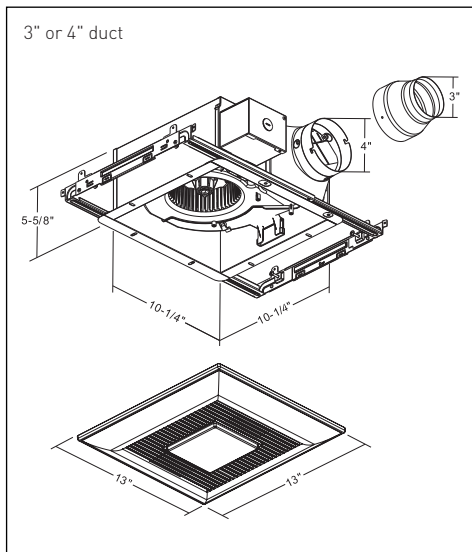

**FV-08-11VFL5E**

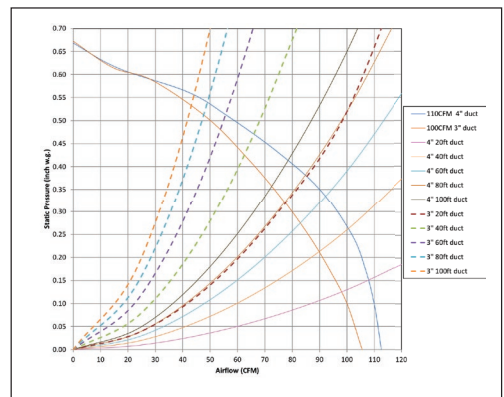

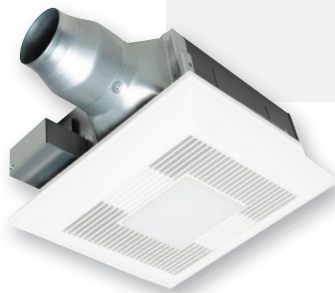

**Panasonic Life Solutions Company of America**  
**IAQ Division**  
Two Riverfront Plaza  
Newark, NJ 07102  
[WhisperFitEZfan.com](http://WhisperFitEZfan.com)

**For Order Information**  
PHONE: 866-292-7299  
FAX: 888-553-0723  
[ventfans@us.panasonic.com](mailto:ventfans@us.panasonic.com)