

### Specification Submittal Data / Panasonic Ventilation Fan

#### Description

Customizable ceiling mount ventilating fan, low sone and rated for continuous operation. ENERGY STAR® rated and certified by the Home Ventilating Institute (HVI). Evaluated by the Underwriters Laboratories and conforms to both UL and cUL standards.

#### Motor/Blower:

- Enclosed brushless ECM smart motor technology rated for continuous operation
- Adjustable ventilation rates at 50 – 80 – 110 CFM
- Power rating of 120 volts and 60 Hz
- UL and cUL listed for tub/shower enclosure when GFCI protected
- Motor equipped with thermal cutoff fuse
- Removable permanently lubricated plug-in motor

#### Housing:

- Environmentally friendly 26 gauge Zinc-Aluminum-Magnesium (ZAM) housing
- Integrated dual 4" or 6" diameter duct adapter
- Built-in damper reduces back draft and helps with blower door testing
- Built-in metal flange provides blocking for penetrations through drywall as an Air Barrier, and assists with the decrease in leakage in the Building Envelope during blower door testing
- Suitable for installation in ceilings insulated up to R60
- Articulating and expandable installation bracket up to 24"

#### Grille:

- Attractive design using Poly Pro material
- Attaches directly to housing with torsion springs
- Includes a motion sensor cap for use as a cover when motion sensor Plug 'n Play™ module has not been selected

#### Warranty:

- ECM Motor: 6 Years from original purchase date
- ALL Parts: 3 Years from original purchase date

#### Architectural Specifications:

Customizable ceiling mount ventilation fan, ENERGY STAR® rated with built-in speed selector. Select from 50/80/110 CFM with <0.3 sone as certified by the Home Ventilating Institute (HVI) at 0.1 w.g. with 51/80/110 CFM and no more than 0.4/0.5/0.8 sones at 0.25 w.g. and 51/79/108 CFM at 0.375 w.g. Power Consumption shall be no greater than 9.9/7.9/6.5 watts at 0.1 w.g. and 15.4/13.1/11.2 watts at 0.25 w.g. and 9.6/13.4/20.0 watts at 0.375 w.g. ENERGY STAR® rated with efficiency of no less than 16.2/15.7/11.1 CFM/watt at 0.1 w.g. and 8.3/8.3/7.1 CFM/watt at 0.25 w.g. and 5.3/5.9/5.4 CFM/watt at 0.375 w.g. The motor shall be enclosed with brushless ECM motor engineered to run continuously. ECM motor speed shall automatically increase when the fan senses static pressure to maintain selected CFM. Power rating shall be 120v/60Hz. Duct diameter shall be no less than 4", inclusive of an integrated dual 4" or 6" duct adapter. **Plug 'N Play™ modules** provide up to three additional features. Select from Multi-Speed with Time Delay, Condensation Sensor, and Motion Sensor. Fan shall be RoHS Compliant and UL and cUL listed for tub/shower enclosure when GFCI protected. Also suitable for installation in ceilings insulated up to R60. Fan can be used to comply with ASHRAE 62.2, LEED, ENERGY STAR® IAP, EarthCraft, California Title-24 and WA Ventilation Code.



#### ECM Motor Technology:

When fan senses static pressure, its speed is automatically increased to ensure that the desired CFM is not compromised, which allows the fan to perform as rated.

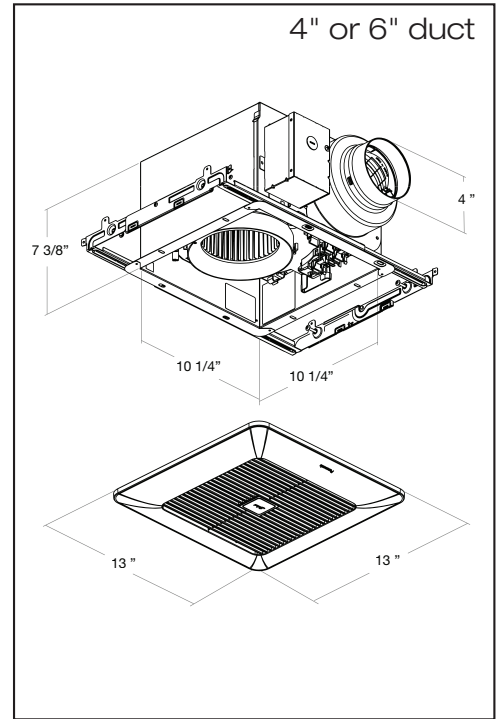

FV-0511VK2

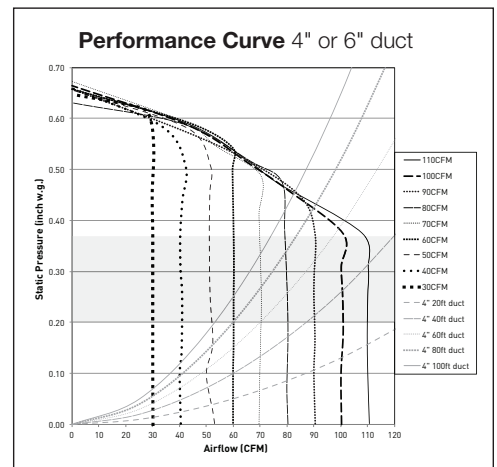

\*Industry research indicates static pressure in typical installations ranges from 0.20" to 0.375"

Model	Quantity	Comments	Project:
			Location:
			Architect:
			Engineer:
			Contractor:
			Submitted by:
			Date:

For complete Installation Instructions visit [us.panasonic.com/ventfans](http://us.panasonic.com/ventfans)

## Plug 'N Play™ Modules

Plug 'N Play™ modules provide up to three additional features. Select from Multi-Speed with Time Delay, Motion Sensor, and Condensation Sensor.



### FV-VS15VK1: Multi-Speed with Time Delay

Allows you to select the proper CFM settings to satisfy ASHRAE 62.2 continuous ventilation requirements. The fan runs continuously at a pre-set lower level (0, 30-100 CFM, in 10 CFM increments), then elevates to a maximum level of operation (50-80-110 CFM) when the wall switch is turned on, or when the motion sensor or Condensation Sensor module is activated. A High/Low delay timer returns the fan to the pre-set CFM level after a period of time set by the user.



### FV-MSVK1: Motion Sensor

Automatically activates when someone enters the room. Once the settings have been applied, the fan becomes truly automatic. This module also activates a 20 minute delay off timer for the fan.



### FV-CSVK1: Condensation Sensor

Helps control bathroom condensation to prevent mold and mildew. Sensor technology detects relative humidity and temperature to anticipate dew point, automatically turning the fan on to control humidity. Built-in Relative Humidity (RH) sensitivity adjustment enables fine tuning for moist conditions and for satisfying CalGreen requirements. When the condensation sensor is used in conjunction with multi-speed functionality, the fan will kick up to high speed when the condensation sensor detects moisture in the room. This module also activates a 20 minute delay off timer for the fan.

Fan Specifications	WhisperGreen Select™ FV-0511VK2								
	0.1	0.25	0.375	0.1	0.25	0.375	0.1	0.25	0.375
Static Pressure in inches w.g.	0.1	0.25	0.375	0.1	0.25	0.375	0.1	0.25	0.375
Air Volume (CFM)	110	110	108	80	80	79	50	51	51
Noise (sones)	<0.3	0.8	-	<0.3	0.5	-	<0.3	0.4	-
Power Consumption (watts)	9.9	15.4	20.0	5.1	9.6	13.4	3.1	6.2	9.6
Energy Efficiency (CFM/Watt)	11.1	7.1	5.4	15.7	8.3	5.9	16.2	8.3	5.3
Speed (RPM)	920	1182	1356	795	1113	1315	722	1054	1266
Current (amps)	0.10	0.16	0.20	0.06	0.10	0.14	0.04	0.07	0.10
MAX. Current(amps)	0.20								
Power Rating (V/Hz)	120/60								
ENERGY STAR rated	Yes								

\*Industry research indicates static pressure in typical installations ranges from 0.20" to 0.375"

Fan Specifications	WhisperGreen Select™: FV-0511VK2 + FV-VS15VK1 (Multi Speed Plug 'N Play™ Module)																										
	0.1	0.25	0.375	0.1	0.25	0.375	0.1	0.25	0.375	0.1	0.25	0.375	0.1	0.25	0.375	0.1	0.25	0.375	0.1	0.25	0.375	0.1	0.25	0.375	0.1	0.25	0.375
Static Pressure in inches w.g.	0.1	0.25	0.375	0.1	0.25	0.375	0.1	0.25	0.375	0.1	0.25	0.375	0.1	0.25	0.375	0.1	0.25	0.375	0.1	0.25	0.375	0.1	0.25	0.375	0.1	0.25	0.375
Air Volume (CFM)	110	110	108	100	101	101	90	90	90	80	80	79	70	71	70	60	60	60	50	51	51	40	41	40	30	30	30
Noise (sones)	<0.3	0.8	-	<0.3	0.7	-	<0.3	0.6	-	<0.3	0.5	-	<0.3	0.5	-	<0.3	0.4	-	<0.3	0.4	-	<0.3	0.3	-	<0.3	0.3	-
Power Consumption (watts)	9.9	15.4	20.0	7.9	13.1	17.8	6.5	11.2	16.0	5.1	9.6	13.4	4.3	8.5	12.1	3.7	6.9	10.5	3.1	6.2	9.6	2.7	5.5	7.8	2.4	4.6	6.8
Energy Efficiency (CFM/Watt)	11.1	7.1	5.4	12.7	7.7	5.7	13.9	8.0	5.6	15.7	8.3	5.9	16.7	8.5	5.9	16.3	8.7	5.7	16.2	8.3	5.3	14.8	7.4	5.1	12.6	6.6	4.4
Speed (RPM)	920	1182	1356	889	1164	1356	839	1135	1351	795	1113	1315	760	1112	1309	751	1061	1287	722	1054	1266	707	1057	1251	711	1039	1259
Current (amps)	0.10	0.16	0.20	0.09	0.14	0.18	0.07	0.12	0.16	0.06	0.10	0.14	0.05	0.09	0.13	0.05	0.08	0.11	0.04	0.07	0.10	0.04	0.07	0.09	0.04	0.06	0.08
MAX. Current(amps)	0.20																										
Power Rating (V/Hz)	120/60																										
ENERGY STAR rated	Yes																										

\*Industry research indicates static pressure in typical installations ranges from 0.20" to 0.375"

Panasonic Life Solutions Company of America  
IAQ Division  
Two Riverfront Plaza  
Newark, NJ 07102

us.panasonic.com/ventfans

