

Job Name:

System Reference:

Date:

Indoor Unit:
SVZ-KP12NAOutdoor Unit:
SUZ-KA12NAR1

INDOOR UNIT FEATURES

- Ducted air handler provides a solution to cool and heat larger zones
- Highly efficient completely enclosed EC motor
- Selectable external static pressure: 0.30, 0.50 and 0.80 in.WG with 3 fan speeds at each static setting
- 1 inch R4.2 fiberglass free insulation reduces condensation and increases efficiency
- Positive pressure cabinet with air leakage of less than 2.0% at 1.0 in. w.g. (Tested per ASHRAE Standard 193)
- Unique blow through design allows simple coil cleaning when the blower is removed
- Multi-position installation: horizontal (left or right), vertical (upflow)
- Optional electric heat kit for additional heating capacity
- Optional humidifier control, ERV control and auxiliary heat control
- Optional downflow kit

OUTDOOR UNIT FEATURES

- Variable speed INVERTER-driven compressor
- Innovative Joint Lap DC Motor leads to high efficiency and reliability
- Pulse Amplitude Modulation technology
- High-performance grooved piping for increased heat exchange efficiency

SPECIFICATIONS: SVZ-KP12NA & SUZ-KA12NAR1

Cooling ¹	Maximum Capacity	Btu/h	12,000
	Rated Capacity	Btu/h	12,000
	Minimum Capacity	Btu/h	3,700
	Maximum Power Input	W	960
	Rated Power Input	W	960
	Moisture Removal	Pints/h	1.80
	Sensible Heat Factor		0.83
	Power factor	%	90.0
Heating at 47°F ²	Maximum Capacity	Btu/h	13,500
	Rated Capacity	Btu/h	13,500
	Minimum Capacity	Btu/h	5,000
	Maximum Power Input	W	1,210
	Rated Power Input	W	1,210
	Power factor	%	96.0
Heating at 17°F ³	Maximum Capacity	Btu/h	8,800
	Rated Capacity	Btu/h	8,800
	Maximum Power Input	W	1,060
	Rated Power Input	W	1,060
Efficiency	SEER		17.0
	EER ¹		12.5
	HSPF (IV)		10.0
	COP at 47° F ²		3.20
	COP at 17° F ³		2.40
	ENERGY STAR® Certified (ENERGY STAR products are third-party certified by an EPA-recognized Certification Body.)		Yes
Electrical	Voltage, Phase, Frequency		208/230V,1-phase,60Hz
	Guaranteed Voltage Range	V AC	187 - 253
	Voltage: Indoor - Outdoor, S1-S2	V AC	208 / 230
	Voltage: Indoor - Outdoor, S2-S3	V DC	24
	Voltage: Indoor - Remote Controller	V DC	12
	Recommended Fuse/Breaker Size	A	15
	Recommended Wire Size (Indoor - Outdoor)	AWG	14
Indoor unit	MCA	A	3
	Fan Motor Full Load Amperage	A	2.4
	Fan Motor Output	W	121
	Airflow Rate, Dry	CFM	278-381-448
	Airflow Rate, Wet	CFM	278-381-448
	External Static Pressure	in.WG	0.3 - 0.5 - 0.8
	Sound Pressure Level at 0.14 in. WG	dB(A)	29-36-39
	Drain Pipe Size	In. (mm)	3/4 (19.05) FPT
	Condensate Lift Mechanism, Max. Distance	In. (mm)	N/A

SPECIFICATIONS: SVZ-KP12NA & SUZ-KA12NAR1

	Heat Exchanger Type		Plate fin coil
	External finish color		Hot-dip coated steel (ZAM)
	Unit Dimensions	W: In. (mm)	17 (432)
		D: In. (mm)	21-5/8 (548)
		H: In. (mm)	39-13/16 (1,011)
	Package Dimensions	W: In. (mm)	18 (460)
		D: In. (mm)	28-3/4 (730)
H: In. (mm)		44-3/8 (1,130)	
Unit Weight	Lbs. (kg)	93 (42)	
Package Weight	Lbs.	106	
Indoor unit operating temperature range	Cooling Intake Air Temp (Maximum / Minimum)	°F	95 DB, 71 WB / 67 DB, 57 WB
	Heating Intake Air Temp (Maximum / Minimum)	°F	80 DB, 67 WB / 70 DB, 60 WB
Outdoor Unit	MCA	A	12
	MOCP	A	15
	Fan Motor Full Load Amperage	A	0.5
	Fan Motor Output	W	55
	Airflow Rate	CFM	1,229 / 1,172
	Refrigerant Control		LEV
	Defrost Method		Reverse cycle
	Heat Exchanger Type		Plate fin coil
	Sound Pressure Level, Cooling ¹	dB(A)	49
	Sound Pressure Level, Heating ²	dB(A)	51
	Compressor Type		DC INVERTER-driven
	Compressor Model		KNB092FQAHC
	Compressor Rated Load Amps	A	6.6
	Compressor Locked Rotor Amps	A	8.2
	Compressor Oil Type // Charge	oz.	NEO22 // 10.8
	External Finish Color		Munsell 3Y 7.8/1.1
	Base Pan Heater		Optional (MAC-640BH-U)
	Unit Dimensions	W: In. (mm)	31-1/2 (800)
		D: In. (mm)	11-1/4 (285)
		H: In. (mm)	21-5/8 (550)
Package Dimensions	W: In. (mm)	37 (940)	
	D: In. (mm)	14-3/4 (380)	
	H: In. (mm)	24-1/2 (630)	
Unit Weight	Lbs. (kg)	77 (35)	
Package Weight	Lbs. (kg)	84 (38)	
Outdoor Unit Operating Temperature Range	Cooling Air Temp (Maximum / Minimum)	°F	115 / 14
	Cooling Thermal Lock- out / Re-start Temperatures**	°F	-7 / -4
	Heating Air Temp (Maximum / Minimum)	°F	75 / 12
	Heating Thermal Lock- out / Re-start Temperatures**	°F	-7 / -4

SPECIFICATIONS: SVZ-KP12NA & SUZ-KA12NAR1

Refrigerant	Type		R410A
	Charge	Lbs, oz	2, 9
Piping	Gas Pipe Size O.D. (Flared)	In.(mm)	3/8 (9.52)
	Liquid Pipe Size O.D. (Flared)	In.(mm)	1/4 (6.35)
	Maximum Piping Length	Ft. (m)	65 (20)
	Maximum Height Difference	Ft. (m)	40 (12)
	Maximum Number of Bends		10

Notes

AHRI Rated Conditions (Rated data is determined at a fixed compressor speed)	¹ Cooling (Indoor // Outdoor)	°F	80 DB, 67 WB // 95 DB, 75 WB
	² Heating at 47°F (Indoor // Outdoor)	°F	70 DB, 60 WB // 47 DB, 43 WB
	³ Heating at 17°F (Indoor // Outdoor)	°F	70 DB, 60 WB // 17 DB, 15 WB

*Applications should be restricted to comfort cooling only; equipment cooling applications are not recommended for low ambient temperature conditions.

**System cuts out at -7°F (-21.7°C) to avoid thermistor error and automatically restarts at -4°F (-20°C).

ACCESSORIES: SVZ-KP12NA

Wireless Signal Receiver	<input type="checkbox"/> PAR-FA32MA-W
Wireless Signal Receiver	<input type="checkbox"/> PAR-FA32MA-E
Wireless Remote Controller	<input type="checkbox"/> PAR-FL32MA-E
Backlit, Wall-mounted, Wireless Controller	<input type="checkbox"/> MHK1
Portable Central Controller	<input type="checkbox"/> MCCH1
Wired MA Controller	<input type="checkbox"/> PAR-33MAA
Simple MA Controller	<input type="checkbox"/> PAC-YT53CRAU
Touch MA Controller	<input type="checkbox"/> PAR-CT01MAU-SB
Airzone ZBS Wired Blueface Principal Controller White	<input type="checkbox"/> AZZBSBLUEFACECB
Airzone ZBS Wired Think Controller White	<input type="checkbox"/> AZZBSTHINKCB
Airzone ZBS Wireless Think Controller White	<input type="checkbox"/> AZZBSTHINKRB
Airzone ZBS Wired Lite Controller White	<input type="checkbox"/> AZZBSLITECB
Airzone ZBS Wireless Lite Controller White	<input type="checkbox"/> AZZBSLITERB
Wired Remote Sensor	<input type="checkbox"/> PAC-SE41TS-E
Wireless Temperature and Humidity Sensor	<input type="checkbox"/> PAC-USWHS003-TH-1
Outside Air Sensor for MHK1	<input type="checkbox"/> MOS1
Flush Mount Remote Temperature Sensor	<input type="checkbox"/> PAC-USSEN001-FM-1
Wireless Interface	<input type="checkbox"/> PAC-USWHS002-WF-1
Thermostat Interface	<input type="checkbox"/> PAC-US444CN-1
kumo station®	<input type="checkbox"/> PAC-WHS01HC-E
USNAP Interface	<input type="checkbox"/> PAC-WHS01UP-E
IT Extender	<input type="checkbox"/> PAC-WHS01IE-E
BACnet® and MODBUS® Interface	<input type="checkbox"/> PAC-UKPRC001-CN-1
External Fan / Heater Control Relay Adapter	<input type="checkbox"/> CN24RELAY-KIT-CM3
Connector cable for remote display	<input type="checkbox"/> PAC-SA88HA-EP
Connector for CN32 (remote on/off)	<input type="checkbox"/> PAC-SE55RA-E
Remote Operation Adapter ¹	<input type="checkbox"/> PAC-SF40RM-E
MegaBlue Advanced Blue Diamond Condensate Pump w/ Reservoir & Sensor	<input type="checkbox"/> X87-835 - 110 to 250V
MaxiBlue Advanced Blue Diamond Mini Condensate Pump w/ Reservoir & Sensor (110V) up to 48,000 Btu/h [recommended]	<input type="checkbox"/> X87-711 - 110V
Advanced Blue Diamond Mini Condensate Pump w/ Reservoir & Sensor (208/230V) [recommended]	<input type="checkbox"/> X87-721 - 208/230V
Drain Pan Level Sensor	<input type="checkbox"/> DPLS2
(30A/600V/UL) [fits 2" X 4" utility box] - Black	<input type="checkbox"/> TAZ-MS303
(30A/600V/UL) [fits 2" X 4" utility box] - White	<input type="checkbox"/> TAZ-MS303W
Separate Power Terminal Block Kit	<input type="checkbox"/> SPTB1
Electric Heat Lockout Control	<input type="checkbox"/> ETC-211000-000
Downflow Kit	<input type="checkbox"/> DFK-S
3kW Electric Heater	<input type="checkbox"/> EH03-SVZ-S
5kW Electric Heater	<input type="checkbox"/> EH05-SVZ-S

¹ Unable to use with wireless remote controller

ACCESSORIES: SUZ-KA12NAR1

Air Outlet Guide	<input type="checkbox"/> MAC-881SG
Optional Defrost Heater	<input type="checkbox"/> MAC-640BH-U
Hail Guard	<input type="checkbox"/> HG-B4
Outdoor Unit 3-1/4 inch Mounting Base (Pair) - Plastic	<input type="checkbox"/> DSD-400P
Condensing Unit Mounting Pad 16" x 36" x 3"	<input type="checkbox"/> ULTRILITE1
Outdoor Unit Stand — 12" High	<input type="checkbox"/> QSMS1201M
Outdoor Unit Stand — 18" High	<input type="checkbox"/> QSMS1801M
Outdoor Unit Stand — 24" High	<input type="checkbox"/> QSMS2401M
Heavy Duty Wall Mounting Bracket— Coated Steel	<input type="checkbox"/> QSWB2000M-1
Heavy Duty Wall Mounting Bracket — 316 Series Stainless Steel	<input type="checkbox"/> QSWBSS
15' x 1/4" x 15' / 3/8" Lineset (Twin-Tube Insulation)	<input type="checkbox"/> MLS143812T-15
30' x 1/4" x 30' / 3/8" Lineset (Twin-Tube Insulation)	<input type="checkbox"/> MLS143812T-30
50' x 1/4" x 50' / 3/8" Lineset (Twin-Tube Insulation)	<input type="checkbox"/> MLS143812T-50
65' x 1/4" x 65' / 3/8" Lineset (Twin-Tube Insulation)	<input type="checkbox"/> MLS143812T-65

DIMENSIONS: SVZ-KP12NA

Unit:mm(in.)

Note: Electrical entrance for SVZ located on both left and right side of the cabinet.
See right or Left side view for knockout locations.

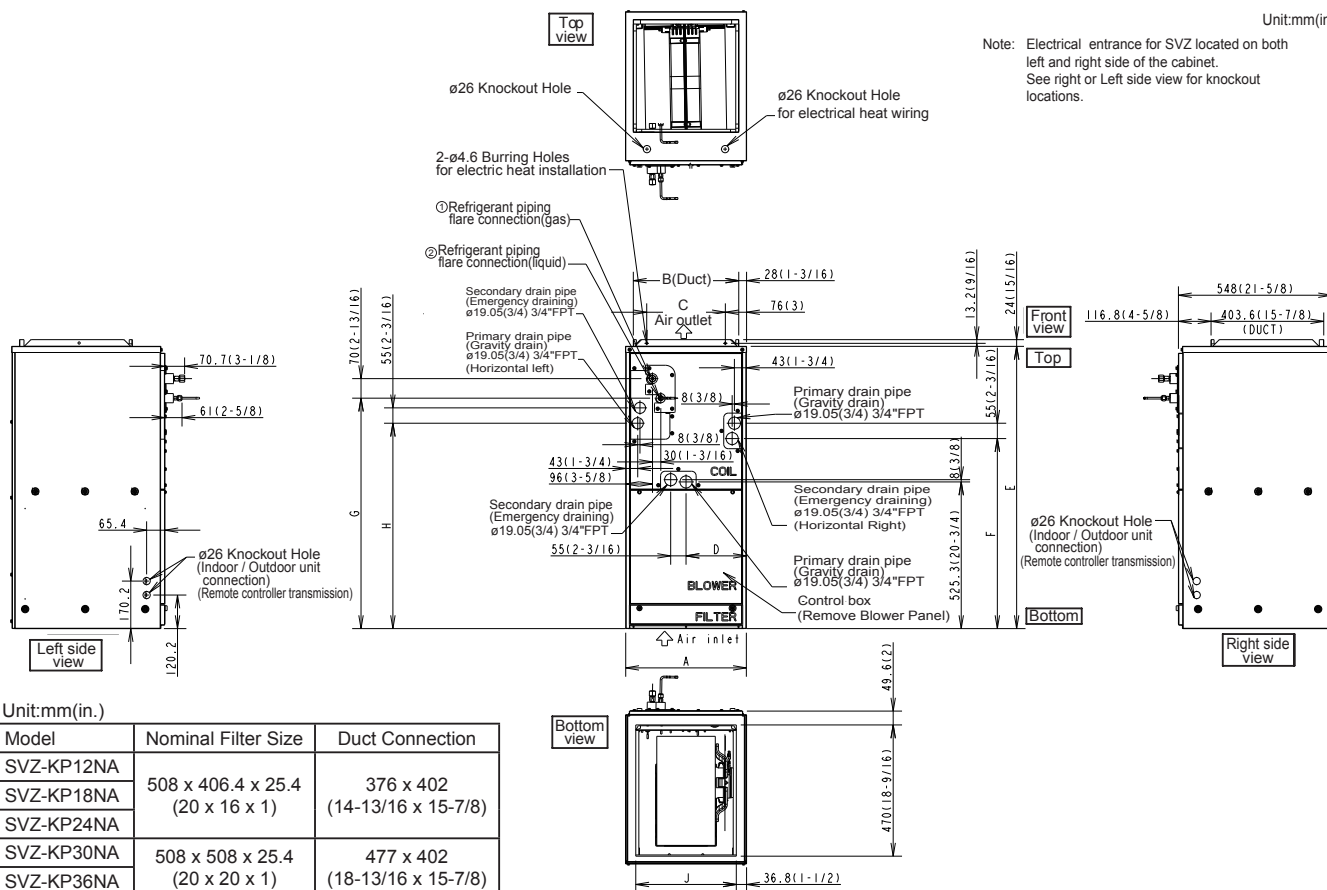

Unit:mm(in.)

Model	Nominal Filter Size	Duct Connection
SVZ-KP12NA	508 x 406.4 x 25.4 (20 x 16 x 1)	376 x 402 (14-13/16 x 15-7/8)
SVZ-KP18NA		
SVZ-KP24NA		
SVZ-KP30NA	508 x 508 x 25.4 (20 x 20 x 1)	477 x 402 (18-13/16 x 15-7/8)
SVZ-KP36NA		

Model	A	B	C	D	E	F	G	H	J	Gas Pipe	Liquid pipe
SVZ-KP12NA	432 (17)	376 (14-13/16)	281 (11-1/8)	224 (8-7/8)	1,010.8 (39-13/16)	680 (26-13/16)	823 (32-7/16)	735.5 (29)	360 (14-3/16)	ø 9.52 (3/8)	ø 6.35 (1/4)
SVZ-KP18NA										ø 12.7 (1/2)	
SVZ-KP24NA											
SVZ-KP30NA	534 (21)	477 (18-13/16)	382.6 (15-1/8)	266.5 (10-1/2)	1,113.8 (43-7/8)	737 (29-1/16)	953.5 (37-9/16)	792 (31-3/16)	461 (18-3/16)	ø 15.88 (5/8)	ø 9.52 (3/8)
SVZ-KP36NA											

DIMENSIONS: SUZ-KA12NAR1

Unit: inch

REQUIRED SPACE

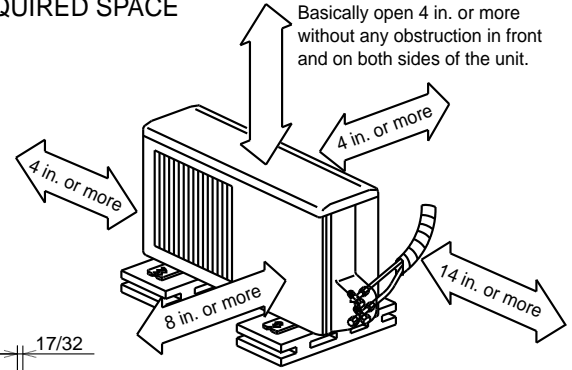
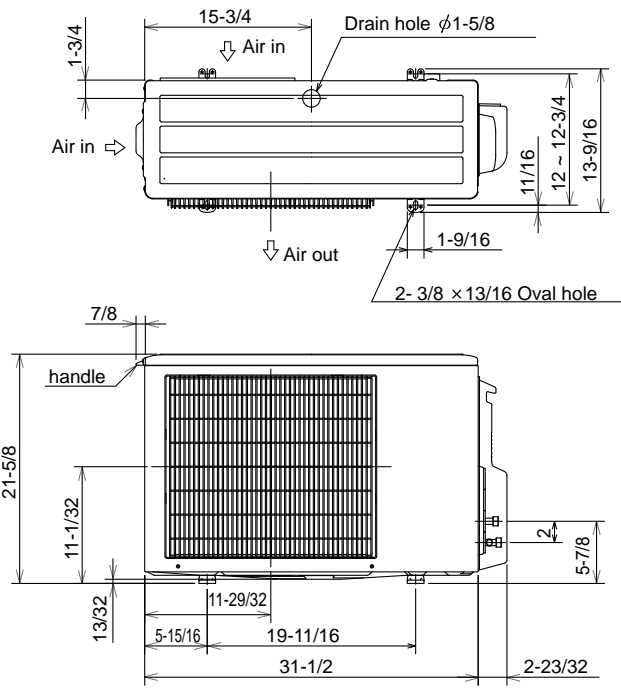

Open two sides of left, right, or rear side.

- Liquid pipe : 1/4 (flared)
- Gas pipe : 3/8 (flared) (KA09/12)
- 1/2 (flared) (KA15)



1340 Satellite Boulevard, Suwanee, GA 30024
 Toll Free: 800-433-4822 www.mehvac.com

FORM# SVZ-KP12NA / SUZ-KA12NAR1 - 201902Ver2



Specifications are subject to change without notice.

© 2019 Mitsubishi Electric Trane HVAC US LLC. All rights reserved.