



# CITY MULTI

Air Conditioners

**PVFX-P08, 12, 18, 24, 30, 36, 48, 54 NAMU-E\***

---

SERVICE PARTS MANUAL

## Table of Contents

1. EXTERNAL PARTS .....	3
2. HEX ASSEMBLY PARTS .....	4
3. BLOWER PARTS .....	5
4. CONTROL BOX PARTS .....	6

# 1. EXTERNAL PARTS

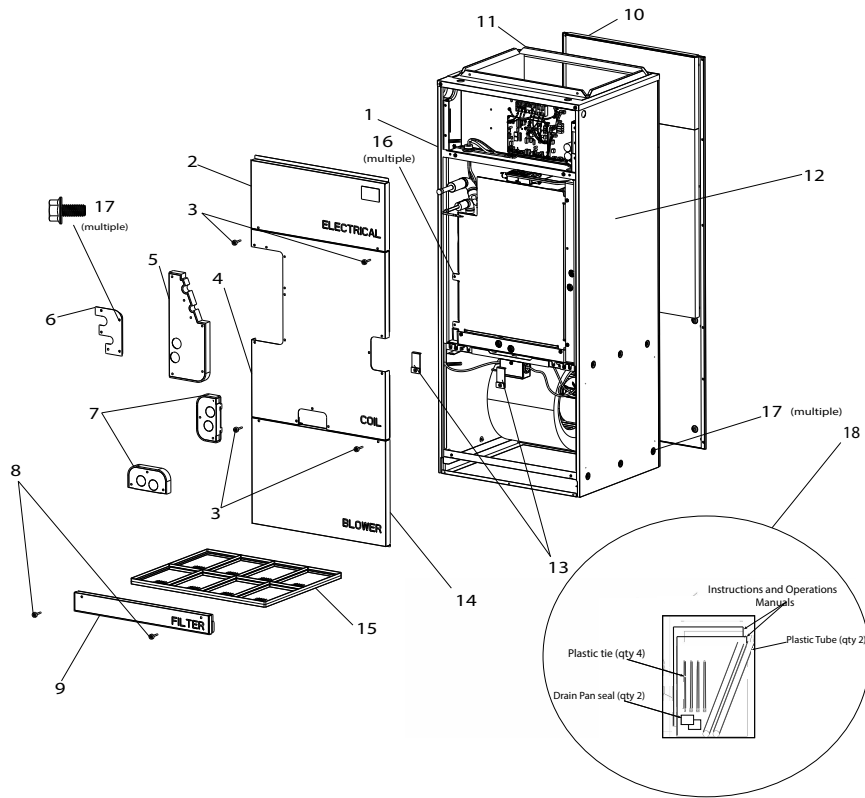

No.	Service Part No.	Part Name	Symbol in Wiring Diagram	Quantity per unit								Remarks
				PVFY-P								
				08NAMU-E*	12NAMU-E*	18NAMU-E*	24NAMU-E*	30NAMU-E*	36NAMU-E*	48NAMU-E*	54NAMU-E*	
1	U41 B03 641	CABINET LEFT S	CN20	1	1	1	1					Black ZAM *
	U41 B02 641	CABINET LEFT M						1	1			Black ZAM *
	U41 B01 641	CABINET LEFT L								1	1	Black ZAM *
2	U41 B01 638	FRONT PANEL ELECTRICAL S		1	1	1	1					Black ZAM
	U41 B02 638	FRONT PANEL ELECTRICAL M						1	1			Black ZAM
	U41 B03 638	FRONT PANEL ELECTRICAL L								1	1	Black ZAM
3	U41 002 087	SCREW M 5X40		4	4	4	4	4	4	4	4	
	U41 B01 639	FRONT PANEL HEX S		1	1	1	1					Black ZAM
4	U41 B02 639	FRONT PANEL HEX M						1	1			Black ZAM
	U41 B03 639	FRONT PANEL HEX L								1	1	Black ZAM
5	U41 B01 635	PIPE/ DRAIN PANEL S		1	1	1	1					Black ZAM
	U41 B02 635	PIPE/ DRAIN PANEL M						1	1			Black ZAM
	U41 B03 635	PIPE/ DRAIN PANEL L								1	1	Black ZAM
6	U41 B04 635	PIPE PANEL		1	1	1	1	1	1	1	1	Black ZAM
7	U41 B05 635	DRAIN PANEL		2	2	2	2	2	2	2	2	Black ZAM
8	U41 001 087	PLASTIC THUMB SCREW		2	2	2	2	2	2	2	2	M 5X35
9	U41 B01 636	FRONT PANEL FILTER S		1	1	1	1					Black ZAM
	U41 B02 636	FRONT PANEL FILTER M						1	1			Black ZAM
	U41 B03 636	FRONT PANEL FILTER L								1	1	Black ZAM
10	U41 B03 640	CABINET BACK S		1	1	1	1					Black ZAM
	U41 B02 640	CABINET BACK M						1	1			Black ZAM
	U41 B01 640	CABINET BACK L								1	1	Black ZAM
11	U41 B03 643	TOP PANEL S		1	1	1	1					Black ZAM
	U41 B02 643	TOP PANEL M						1	1			Black ZAM
12	U41 B01 643	TOP PANEL L								1	1	Black ZAM
	U41 B03 642	CABINET RIGHT S	CNMF	1	1	1	1					Black ZAM **
	U41 B02 642	CABINET RIGHT M						1	1			Black ZAM **
U41 B01 642	CABINET RIGHT L								1	1	Black ZAM **	
13	U41 001 086	COIL BRACKET		1	1	1	1	2	2	2	2	
14	U41 B01 637	FRONT PANEL BLOWER S		1	1	1	1					Black ZAM
	U41 B02 637	FRONT PANEL BLOWER M						1	1			Black ZAM
	U41 B03 637	FRONT PANEL BLOWER L								1	1	Black ZAM
15	U41 004 500	FILTER-PLASTIC S		1	1	1	1					16X20
	U41 005 500	FILTER-PLASTIC M						1	1			20X20
	U41 006 500	FILTER-PLASTIC L								1	1	24X20
16	U41 008 087	SCREW H 5X10 KNURLED (10 pack)		46	46	46	46	46	46	46	46	pack of 10 screws
17	U41 009 087	SCREW M5X12 BLACK (10 pack)		52	52	52	52	52	52	52	52	pack of 10 screws
18	U41 007 818	ACCESSORY BAG		1	1	1	1	1	1	1	1	

\* The return air thermistor adapter harness is pre-installed in the Cabinet Left panel. See Blower Parts section for Thermistor. See Control Box Parts for adapter harness kit.

\*\* The motor harness is pre-installed in the Cabinet Right panel.

# 2. HEX ASSEMBLY PARTS

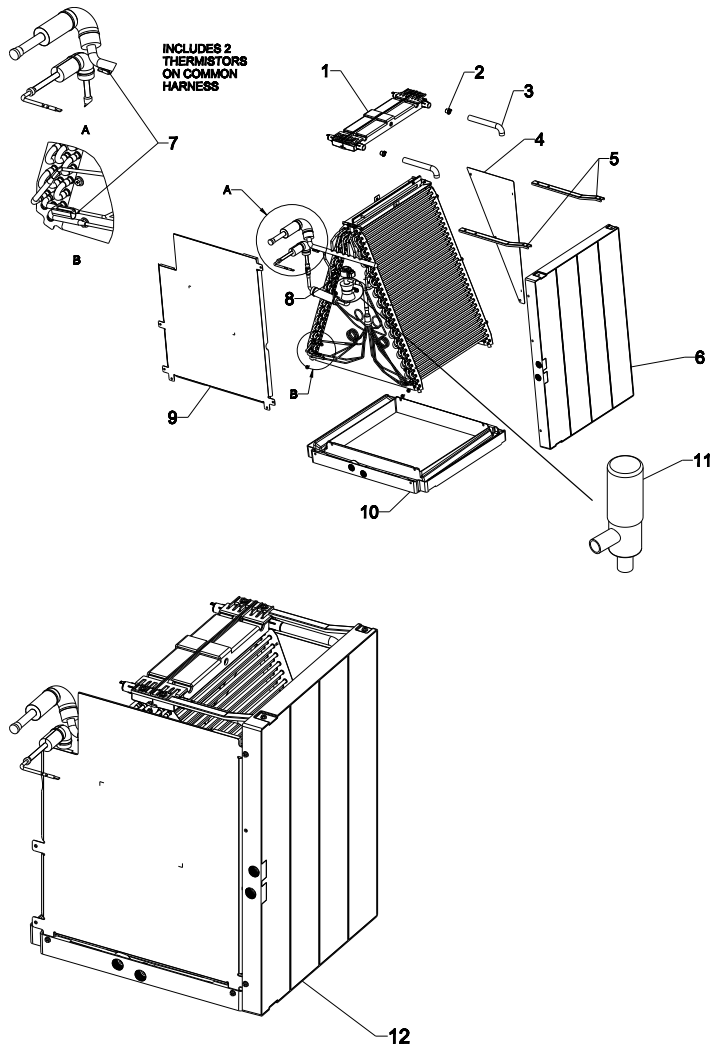

No.	Service Part No.	Part Name	Symbol in Wiring Diagram	Quantity per unit								Remarks	
				PVFY-P									
				08NAMU-E*	12NAMU-E*	18NAMU-E*	24NAMU-E*	30NAMU-E*	36NAMU-E*	48NAMU-E*	54NAMU-E*		
1	U41 012 529	DRAIN PAN ASSY TOP		2	2	2	2	2	2	2	2		
2	U41 002 558	PLUG-TOP DRAIN PAN		4	4	4	4	4	4	4	4		
3	U41 001 525	HOSE-TOP DRAIN PAN		2	2	2	2	2	2	2	2		
4	U41 001 668	PLATE GUIDE REAR S		1	1	1	1						
	U41 002 668	PLATE GUIDE REAR M						1	1				
	U41 003 668	PLATE GUIDE REAR L								1	1		
5	U41 001 662	SIDE PAN BRACKET S		2	2	2	2						
	U41 002 662	SIDE PAN BRACKET M						2	2				
	U41 003 662	SIDE PAN BRACKET L								2	2		
6	U41 009 529	DRAIN PAN ASSY SIDE S		1	1	1	1						
	U41 010 529	DRAIN PAN ASSY SIDE M						1	1				
	U41 011 529	DRAIN PAN ASSY SIDE L								1	1		
7	U41 003 200	THERMISTOR LIQUID/GAS PIPE SENSOR ASSY	CN44	1	1	1	1						TH22/TH23
	U41 004 200	THERMISTOR LIQUID/GAS PIPE SENSOR ASSY						1	1				
	U41 005 200	THERMISTOR LIQUID/GAS PIPE SENSOR ASSY								1	1		
8	U41 001 243	SOLENOID COIL PAM	CN60	1	1	1	1	1	1	1	1		
	U41 004 668	PLATE GUIDE FRONT S		1	1	1	1						
9	U41 005 668	PLATE GUIDE FRONT M						1	1				
	U41 006 668	PLATE GUIDE FRONT L								1	1		
	U41 006 529	DRAIN PAN ASSY LOWER S		1	1	1	1						
10	U41 007 529	DRAIN PAN ASSY LOWER M						1	1				
	U41 008 529	DRAIN PAN ASSY LOWER L								1	1		
	U41 004 401	LEV PAM		1	1	1	1						
11	U41 005 401	LEV PAM						1	1	1			
	U41 006 401	LEV PAM									1		
	U41 030 480	HEAT EXCHANGER P08		1									Includes all HEX parts
12	U41 011 480	HEAT EXCHANGER P12			1	1							Includes all HEX parts
	U41 012 480	HEAT EXCHANGER P24					1						Includes all HEX parts
	U41 013 480	HEAT EXCHANGER P30						1	1				Includes all HEX parts
	U41 014 480	HEAT EXCHANGER P48									1		Includes all HEX parts
	U41 015 480	HEAT EXCHANGER P54										1	Includes all HEX parts

# 3. BLOWER PARTS

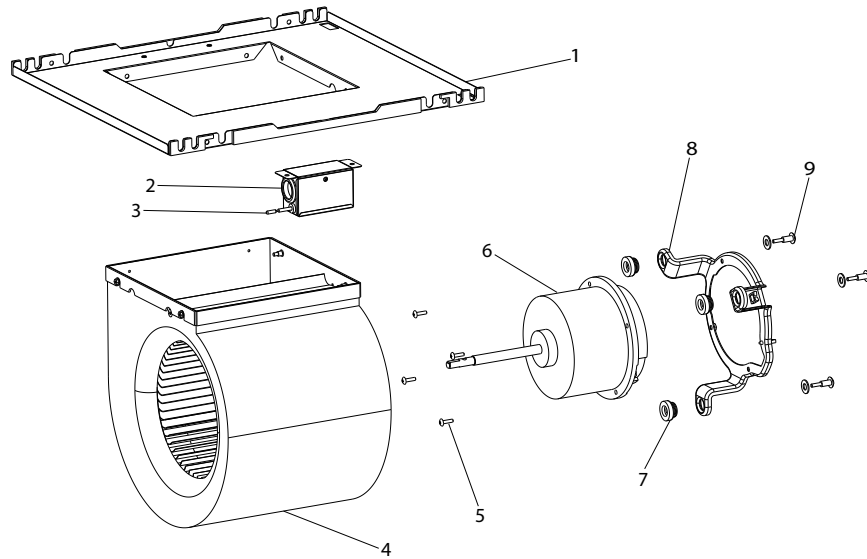

No.	Service Part No.	Part Name	Symbol in Wiring Diagram	Quantity per unit								Remarks	
				PV FY-P									
				08NAMU-E*	12NAMU-E*	18NAMU-E*	24NAMU-E*	30NAMU-E*	36NAMU-E*	48NAMU-E*	54NAMU-E*		
1	U41 015 638	FRAME FAN S		1	1	1	1						
	U41 016 638	FRAME FAN M						1	1				
	U41 017 638	FRAME FAN L								1	1		
2	U41 002 104	BUSHING SRB-R-2		1	1	1	1	1	1	1	1	1	
3	U41 001 287	THERMISTOR RETURN AIR	CN20	1	1	1	1	1	1	1	1	1	TH1
4	U41 008 129	FAN CASE S		1	1	1	1						
	U41 009 129	FAN CASE M						1	1				
	U41 010 129	FAN CASE L								1	1		
5	U41 005 087	BOLT MOTOR (S, M)		4	4	4	4	4	4				
	U41 006 087	BOLT MOTOR (L)								4	4		
	U41 003 128	BLOWER MOTOR S		1	1	1	1						
6	U41 004 128	BLOWER MOTOR M						1	1				
	U41 005 128	BLOWER MOTOR L								1	1		
	U41 103 104	RUBBER GROMMET								3	3		
8	U41 001 130	MOTOR BRACKET S M		1	1	1	1	1	1				
	U41 002 130	MOTOR BRACKET L								1	1		
	U41 003 087	SCREW SPECIAL								3	3		
9	U41 003 130	MOTOR BRACKET BOLT KIT		3	3	3	3	3	3				

# 4. CONTROL BOX PARTS

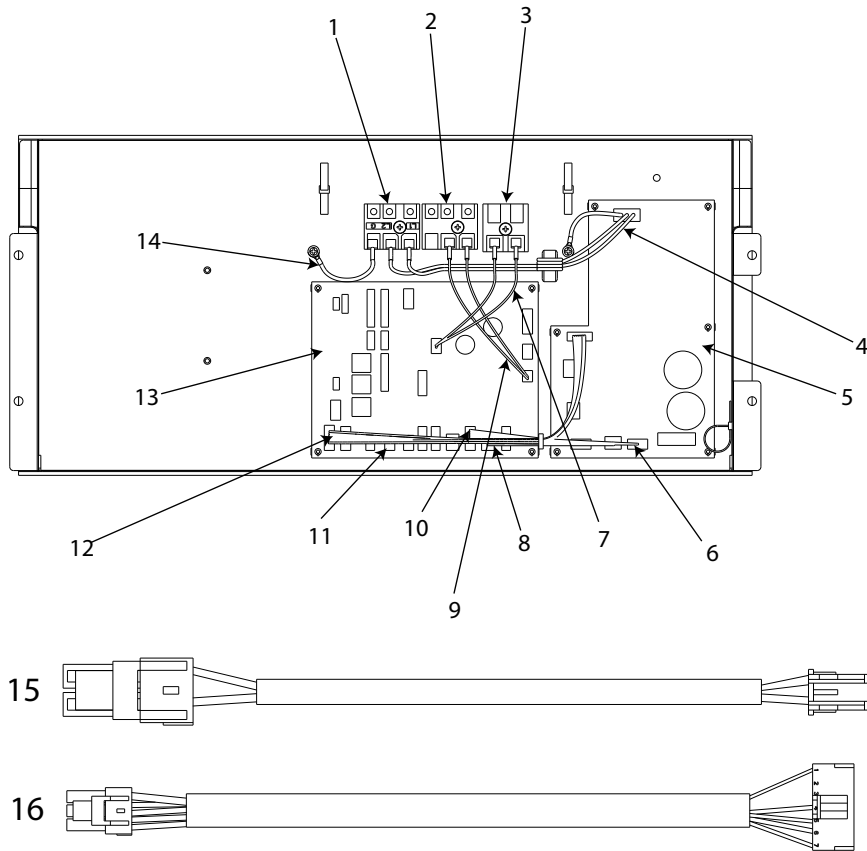

No.	Service Part No.	Part Name	Symbol in Wiring Diagram	Quantity per unit								Remarks	
				PV-FY-P									
				08NAMU-E*	12NAMU-E*	18NAMU-E*	24NAMU-E*	30NAMU-E*	36NAMU-E*	48NAMU-E*	54NAMU-E*		
1	U41 001 246	TERMINAL BED ASSY	TB2	1	1	1	1	1	1	1	1	1	L1, L2, G
2	U41 002 246	TERMINAL BED ASSY	TB5	1	1	1	1	1	1	1	1	1	M1, M2, S
3	U41 003 246	TERMINAL BLOCK	TB15	1	1	1	1	1	1	1	1	1	1, 2
4	U41 007 392	LEAD WIRE ASSY CND S	CND	1	1	1	1	1	1	1	1	1	to Terminal Bed Assy (L1, L2)
	U41 008 392	LEAD WIRE ASSY CND L	CND								1	1	
5	U41 001 281	POWER BOARD		1	1	1	1						
	U41 002 281								1	1			
	U41 003 281										1	1	
6	U71 019 392	LEAD WIRE ASSY XA	CNXA2	1	1	1	1	1	1	1	1	1	to PWR BD CNXA1
7	U41 005 392	LEAD WIRE ASSY CN3A	CN3A	1	1	1	1	1	1	1	1	1	to Terminal Block (1, 2)
8	U71 020 392	LEAD WIRE ASSY XC	CNXC2	1	1	1	1	1	1	1	1	1	to PWR BD CNXC1
9	U41 006 392	LEAD WIRE ASSY CN2M	CN2M	1	1	1	1	1	1	1	1	1	to Terminal Bed Assy (M1, M2)
10	U41 003 392	LEAD WIRE ASSY XB	CNXB2	1	1	1	1	1	1	1	1	1	to PWR BD CNXB1
11	U41 001 G08	JUMPER CONNECTOR	CN4F	1	1	1	1	1	1	1	1	1	
12	U41 014 392	LEAD WIRE ASSY CN7V	CN7V	1	1	1	1	1	1	1	1	1	to PWR BD CNEC1
13	U41 A03 280	CONTROL BOARD		1	1	1	1	1	1	1	1	1	Includes jumper connector, item No. 11
14	U41 009 392	LEAD WIRE ASSY EARTH	(GND)	1	1	1	1	1	1	1	1	1	
15	U41 004 392	RETURN AIR THERMISTOR ADAPTER HARNESS KIT	CN20	1	1	1	1	1	1	1	1	1	Does not include thermistor assembly. See HEX Parts for THERMISTOR RETURN AIR  (Harness also pre-installed in Cabinet Left Panel. See External parts)
16	U41 026 392	MOTOR POWER HARNESS KIT	CNMF	1	1	1	1	1	1	1	1	1	(Harness also pre-installed in Cabinet Right Panel. See External parts)

---

This product is designed and intended for use in the residential, commercial and light-industrial environment.

**mitsubishi** **MITSUBISHI ELECTRIC US, INC.**

[www.mitsubishielectric-usa.com](http://www.mitsubishielectric-usa.com)

Toll Free: 800-433-4822