

Job Name:
System Reference:

Date:

GENERAL FEATURES

Quiet Operation
Optional base pan heater to prevent ice in drain pan
Limited warranty: five years parts and seven years compressors



Outdoor Unit: MXZ-8C48NA

ACCESSORIES

Three-port Branch Box (PAC-MKA30BC)
Five-port Branch Box (PAC-MKA50BC)
Distribution Pipe for Flare Connection
- (MSDD-50AR; necessary for installing two branch boxes)
Distribution Pipe for Brazed Connection
- (MSDD-50BR; necessary for installing two branch boxes)
3/8" x 1/2" Port Adapter (MAC-A454JP)
1/2" x 3/8" Port Adapter (MAC-A455JP)
1/2" x 5/8" Port Adapter (MAC-A456JP)
1/4" x 3/8" Port Adapter (PAC-493PI)
3/8" x 5/8" Port Adapter (PAC-SG76RJ)
Base Heater (PAC-SJ20BH-E)

(For data on specific indoor units, see the MXZ-C Technical and Service Manual.)

Specifications			Model Name
Unit Type			MXZ-8C48NA
Cooling* (Non-ducted / Ducted)	Rated Capacity	Btu/h	48,000 / 48,000
	Capacity Range	Btu/h	15,500 - 48,000
	Rated Total Input	W	4,000 / 5,050
Heating at 47°F* (Non-ducted / Ducted)	Rated Capacity	Btu/h	54,000 / 54,000
	Capacity Range	Btu/h	22,500 - 54,000
	Rated Total Input	W	4,220 / 4,990
Heating at 17°F* (Non-ducted/Ducted)	Rated Capacity	Btu/h	35,000 / 35,000
	Maximum Capacity	Btu/h	36,600 / 36,600
	Rated Total Input	W	3,720 / 4,420
Connectable Capacity		Btu/h	12,000 - 62,400
Electrical Requirements	Power Supply	Voltage, Phase, Hertz	208 / 230V, 1-Phase, 60 Hz
	Recommended Fuse/Breaker Size	A	40
	MCA	A	37
Voltage	Indoor - Outdoor S1-S2	V	AC 208 / 230
	Indoor - Outdoor S2-S3	V	DC ±24
Compressor			Hermetic
Fan Motor (ECM)		F.L.A.	0.4+0.4
Sound Pressure Level	Cooling	dB(A)	51
	Heating	dB(A)	54
External Dimensions (H x W x D)		In mm	52-11/16 x 41-11/32 x 13+1 (1338 x 1050 x 330+25)
Net Weight		Lbs / kg	269 (122)
External Finish			Munsell No. 3Y 7.8/11
Refrigerant Pipe Size O.D.	Liquid (High Pressure)	In / mm	3/8 (9.52)
	Gas (Low Pressure)	In / mm	5/8 (15.88)
Max. Refrigerant Line Length		Ft / m	492 (150)
Max. Piping Length between outdoor unit and branch boxes		Ft / m	180 (55)
Max. Piping Length after branch box		Ft / m	82 (25)
Max. Total Piping Length between branch boxes and indoor units		Ft / m	311 (95)
Max. Refrigerant Pipe Height Difference	If IDU is Above ODU	Ft / m	131 (40)
	If IDU is Below ODU	Ft / m	164 (50)
Connection Method			Flared/Flared
Refrigerant			R410A

* Rating Conditions per AHRI Standard:

Cooling | Indoor: 80° F (27° C) DB / 67° F (19° C) WB

Cooling | Outdoor: 95° F (35° C) DB / 23.9° C (75° F) WB

Heating at 47°F | Indoor: 70° F (21° C) DB / 60° F (16° C) WB

Heating at 47°F | Outdoor: 47° F (8° C) DB / 43° F (6° C) WB

Heating at 17° F | Indoor: 70° F (21° C) DB

Heating at 17° F | Outdoor: 17° F (-8° C) DB / 15° F (-9° C) WB

SPECIFICATIONS: MXZ-8C48NA

OPERATING RANGE:

	Outdoor
Cooling	23 to 115° F (-5 to 46° C) DB*1
Heating	-4 to 59° F (-20 to 15° C) WB

*1. D.B. 5 to 115° F [D.B. -15 to 46° C], when an optional Air Outlet Guide is installed.

ENERGY EFFICIENCIES:

Indoor Unit Type	SEER	EER	HSPF	COP @ 47°F	COP @ 17°F
Non-ducted	18.9	12.00	11.4	3.75	2.60
Ducted and Non-ducted	16.8	10.75	10.8	3.46	2.45
Ducted	14.7	9.50	10.1	3.17	2.30

NOTES:

- Minimum of two Indoor Units must be connected to the MXZ-8C48NA.
- Minimum installed capacity cannot be less than 12,000 Btu/h.
- Total connected capacity must not exceed 130% of outdoor unit capacity.
- System can operate with only one Indoor Unit turned on.
- Information provided at 208/230V.
- For Reference:
 - MXZ-C Technical & Service Manual for detailed specifications and additional information per Indoor Unit Combination.
 - MXZ Series Multi-Zone Indoor/Outdoor Combination Table for allowed unit combinations.

MVZ CONNECTION RULES:

- Up to 2 MVZ's may be connected to this system*.
- When 2 MVZ's are connected, no additional indoor units can be used*.
- When 1 MVZ is connected, additional indoor units can be connected.
- When 1 MVZ is connected, total connected capacity must not exceed 130%.

*No limitation to the number of units connected when the SPTB1 accessory is used, total connected capacity must not exceed 130% (refer to SPTB1 documentation for more information).

NOTES:

MXZ-8C48NA SYSTEM DESIGN

Outdoor unit		MXZ-8C48NA	
		5HP	
	Rated capacity (kBTU/h)	Cooling	48
		Heating	54
		Refrigerant R410A	
Connectable indoor unit	Capacity	Type 06 to Type 36	
		Caution: The indoor unit which rated capacity exceeds 36 kBTU/h (Type 36) can NOT be connected.	
	Number of units	2 to 8 units	
	Total system wide capacity	25 to 130% of outdoor unit capacity (12 to 62.4 kBTU/h)	
Connectable	Number of units	1 or 2 units	

Branch box	PAC-MKA50BC & PAC-MKA51BC	PAC-MKA30BC & PAC-MKA31BC
Number of branches (Indoor unit that can be connected)	5 branches (MAX. 5 units)	3 branches (MAX. 3 units)

Note: A maximum of 2 branch boxes can be connected to 1 outdoor unit.

- If Using One Branch Box
Flare connection employed (No brazing)

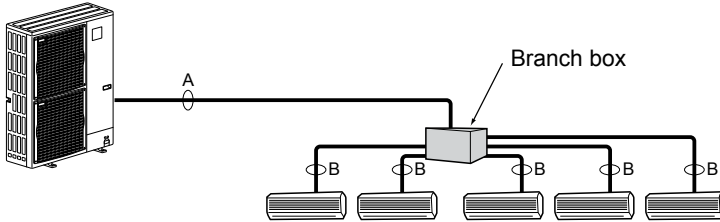

- If Using Two Branch Boxes

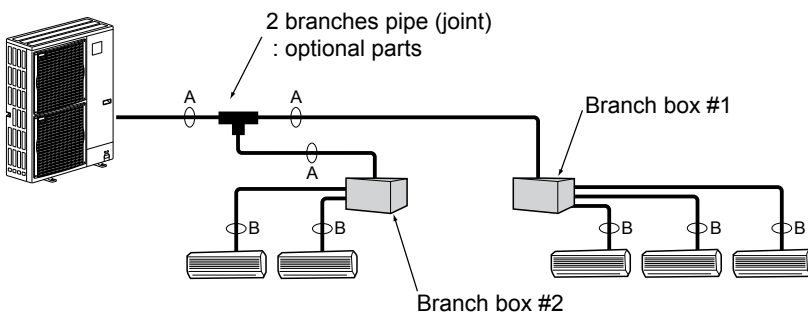

- Installation procedure (2 branches pipe (joint))
Refer to the installation manuals of MSDD-50AR-E and MSDD-50BR-E.

Branch Box Combinations	
Three-port	Five-port
1	0
0	1
1	1
2	0
0	2 (Up to 8 IDU)

Piping connection size

	A	B
Liquid	$\phi 9.52$ mm (3/8 inch)	The piping connection size differs according to the type and capacity of indoor units. Match the piping connection size of branch box with indoor unit. If the piping connection size of branch box does not match the piping connection size of indoor unit, use optional different-diameter (deformed) joints to the branch box side. (Connect deformed joint directly to the branch box side.)
Gas	$\phi 15.88$ mm (5/8 inch)	

MXZ-8C48NA COOLING AND HEATING CAPACITY AND CHARACTERISTICS

1. Method for obtaining system cooling and heating capacity:

To obtain the system cooling and heating capacity and the electrical characteristics of the outdoor unit, first add up the ratings of all the indoor units connected to the outdoor unit (see table below). For Standard Capacity Diagram, please refer to the MXZ-C Technical & Service Manual.

(1) Capacity of indoor unit

	Model Number for indoor unit	Model 06	Model 09	Model 12	Model 15	Model 18	Model 24	Model 30	Model 36
M series	Model Capacity [kBTU/h]	6.0	9.0	12.0	14.0* ¹ 15.0* ²	17.2* ³ 18.0* ⁴	22.5	—	—
P series		—	—	12.0	—	18.0	24.0	30.0	35.0
SEZ		—	8.1	11.5	14.1	17.2	—	—	—
SLZ		—	8.4	11.1	15.0	—	—	—	—
MVZ		—	—	12.0	—	18.0	24.0	30.0	36.0

*1 The value is for MSZ-GE15NA.

*2 The value is for MSZ-FH15NA.

*3 The value is for MSZ-GE/FH18NA.

*4 The value is for MSZ-FE18NA or MFZ-KA18NA.

(2) Sample calculation

1 System assembled from indoor and outdoor unit (in this example the total capacity of the indoor units is greater than that of the outdoor unit)

- Outdoor unit MXZ-5C42NAHZ
- Indoor unit MSZ-GE09NA × 2 + MSZ-FH15NA × 2

2 According to the conditions in 1, the total capacity of the indoor unit will be: 9.0 × 2 + 15.0 × 2 = 48.0

3 The following figures are obtained from the 16.8 total capacity of indoor units, referring the standard capacity diagram in "4-3-3. MXZ-5C42NAHZ <cooling>" and "4-3-4. MXZ-5C42NAHZ <heating>".

Capacity (kBTU/h)		Outdoor unit power consumption (kW)		Outdoor unit current (A)/ 230 V	
Cooling	Heating	Cooling	Heating	Cooling	Heating
A 42.0	B 48.0	3.46	4.37	15.26	19.31

2. Method for obtaining the heating and cooling capacity of an indoor unit:

(1) The capacity of each indoor unit (kW) = the capacity A (or B) × $\frac{\text{model capacity}}{\text{total model capacity of all indoor units}}$

(2) Sample calculation (using the system described above in 4-1-1. (2)):

During cooling:

- The total model capacity of the indoor unit is:
9.0 × 2 + 15.0 × 2 = 48.0 kBTU/h
Therefore, the capacity of MSZ-GE09NA and MSZ-FH15NA will be calculated as follows by using the formula in 4-1-2. (1):

$$\text{Model 09} = 42.0 \times \frac{9.0}{48.0} = 7.88 \text{ kBTU/h}$$

$$\text{Model 15} = 42.0 \times \frac{15.0}{48.0} = 13.13 \text{ kBTU/h}$$

During heating:

- The total model capacity of indoor unit is:
10.9 × 2 + 18.0 × 2 = 57.8 kBTU/h
Therefore, the capacity of MSZ-GE09NA and MSZ-FH15NA will be calculated as follows by using the formula in 4-1-2. (1):

$$\text{Model 25} = 48.0 \times \frac{10.9}{57.8} = 9.05 \text{ kBTU/h}$$

$$\text{Model 50} = 48.0 \times \frac{18.0}{57.8} = 14.95 \text{ kBTU/h}$$

MXZ-8C48NA OPERATIONAL PERFORMANCE, CONTD.

NON-DUCTED:

# of Indoor Unit	Total Nominal Capacity (x1000 Btu/h)	Total Indoor Unit Capacity (Btu/h)	Operational Performance for Indoor Unit Combinations (Unit A + Unit B + Unit C + Unit D + Unit E + Unit F + Unit G + Unit H)	Cooling Capacity Range (Btu/h)							
				Heating Capacity Range (Btu/h)							
				Unit A	Unit B	Unit C	Unit D	Unit E	Unit F	Unit G	Unit H
1	6	6,000	6	6,000	-	-	-	-	-	-	-
		7,200		7,200	-	-	-	-	-	-	
1	9	9,000	9	9,000	-	-	-	-	-	-	-
		10,800		10,800	-	-	-	-	-	-	
1	12	12,000	12	12,000	-	-	-	-	-	-	-
		14,400		14,400	-	-	-	-	-	-	
1	15	15,000	15	15,000	-	-	-	-	-	-	-
		18,000		18,000	-	-	-	-	-	-	
1	18	18,000	18	18,000	-	-	-	-	-	-	-
		21,600		21,600	-	-	-	-	-	-	
1	24	24,000	24	24,000	-	-	-	-	-	-	-
		28,800		28,800	-	-	-	-	-	-	
1	30	30,000	30	30,000	-	-	-	-	-	-	-
		36,900		36,900	-	-	-	-	-	-	
1	36	36,000	36	36,000	-	-	-	-	-	-	-
		45,000		45,000	-	-	-	-	-	-	
2	12	12,000	6 + 6	6,000	6,000	-	-	-	-	-	-
		14,400		7,200	7,200	-	-	-	-	-	
2	15	15,000	6 + 9	6,000	9,000	-	-	-	-	-	-
		18,000		7,200	10,800	-	-	-	-	-	
2	18	18,000	6 + 12	6,000	12,000	-	-	-	-	-	-
		21,600		7,200	14,400	-	-	-	-	-	
2	21	21,000	6 + 15	6,000	15,000	-	-	-	-	-	-
		25,200		7,200	18,000	-	-	-	-	-	
2	24	24,000	6 + 18	6,000	18,000	-	-	-	-	-	-
		28,800		7,200	21,600	-	-	-	-	-	
2	30	30,000	6 + 24	6,000	24,000	-	-	-	-	-	-
		36,900		7,400	29,500	-	-	-	-	-	
2	36	36,000	6 + 30	6,000	30,000	-	-	-	-	-	-
		45,000		7,300	37,700	-	-	-	-	-	
2	42	42,000	6 + 36	6,000	36,000	-	-	-	-	-	-
		48,000		6,600	41,400	-	-	-	-	-	
2	18	18,000	9 + 9	9,000	9,000	-	-	-	-	-	-
		21,600		10,800	10,800	-	-	-	-	-	
2	21	21,000	9 + 12	9,000	12,000	-	-	-	-	-	-
		25,200		10,800	14,400	-	-	-	-	-	
2	24	24,000	9 + 15	9,000	15,000	-	-	-	-	-	-
		28,800		10,800	18,000	-	-	-	-	-	
2	27	27,000	9 + 18	9,000	18,000	-	-	-	-	-	-
		32,800		10,900	21,900	-	-	-	-	-	
2	33	33,000	9 + 24	9,000	24,000	-	-	-	-	-	-
		40,900		11,200	29,700	-	-	-	-	-	
2	39	39,000	9 + 30	9,000	30,000	-	-	-	-	-	-
		46,500		10,500	36,000	-	-	-	-	-	
2	45	45,000	9 + 36	9,000	36,000	-	-	-	-	-	-
		51,000		9,900	41,100	-	-	-	-	-	
2	24	24,000	12 + 12	12,000	12,000	-	-	-	-	-	-
		28,800		14,400	14,400	-	-	-	-	-	
2	27	27,000	12 + 15	12,000	15,000	-	-	-	-	-	-
		32,800		14,600	18,200	-	-	-	-	-	
2	30	30,000	12 + 18	12,000	18,000	-	-	-	-	-	-
		36,900		14,800	22,100	-	-	-	-	-	
2	36	36,000	12 + 24	12,000	24,000	-	-	-	-	-	-
		45,000		15,000	30,000	-	-	-	-	-	
2	42	42,000	12 + 30	12,000	30,000	-	-	-	-	-	-
		48,000		13,500	34,500	-	-	-	-	-	
2	48	48,000	12 + 36	12,000	36,000	-	-	-	-	-	-
		54,000		13,100	40,900	-	-	-	-	-	
2	30	30,000	15 + 15	15,000	15,000	-	-	-	-	-	-
		36,900		18,500	18,500	-	-	-	-	-	
2	33	33,000	15 + 18	15,000	18,000	-	-	-	-	-	-
		40,900		18,600	22,300	-	-	-	-	-	

MXZ-8C48NA OPERATIONAL PERFORMANCE, CONTD.

NON-DUCTED:

# of Indoor Unit	Total Nominal Capacity (x1000 Btu/h)	Total Indoor Unit Capacity (Btu/h)	Operational Performance for Indoor Unit Combinations (Unit A + Unit B + Unit C + Unit D + Unit E + Unit F + Unit G + Unit H)	Cooling Capacity Range (Btu/h)							
				Heating Capacity Range (Btu/h)							
				Unit A	Unit B	Unit C	Unit D	Unit E	Unit F	Unit G	Unit H
2	39	39,000	15 + 24	15,000	24,000	-	-	-	-	-	-
		46,500		17,900	28,600	-	-	-	-	-	
2	45	45,000	15 + 30	15,000	30,000	-	-	-	-	-	-
		51,000		16,700	34,300	-	-	-	-	-	
2	51	48,000	15 + 36	14,100	33,900	-	-	-	-	-	-
		54,000		15,400	38,600	-	-	-	-	-	
2	36	36,000	18 + 18	18,000	18,000	-	-	-	-	-	-
		45,000		22,500	22,500	-	-	-	-	-	
2	42	42,000	18 + 24	18,000	24,000	-	-	-	-	-	-
		48,000		20,600	27,400	-	-	-	-	-	
2	48	48,000	18 + 30	18,000	30,000	-	-	-	-	-	-
		54,000		19,900	34,100	-	-	-	-	-	
2	54	48,000	18 + 36	16,000	32,000	-	-	-	-	-	-
		54,000		17,500	36,500	-	-	-	-	-	
2	48	48,000	24 + 24	24,000	24,000	-	-	-	-	-	-
		54,000		27,000	27,000	-	-	-	-	-	
2	54	48,000	24 + 30	21,300	26,700	-	-	-	-	-	-
		54,000		23,700	30,300	-	-	-	-	-	
2	60	48,000	24 + 36	19,200	28,800	-	-	-	-	-	-
		54,000		21,100	32,900	-	-	-	-	-	
2	60	48,000	30 + 30	24,000	24,000	-	-	-	-	-	-
		54,000		27,000	27,000	-	-	-	-	-	
3	18	18,000	6 + 6 + 6	6,000	6,000	6,000	-	-	-	-	-
		21,600		7,200	7,200	7,200	-	-	-	-	
3	21	21,000	6 + 6 + 9	6,000	6,000	9,000	-	-	-	-	-
		25,200		7,200	7,200	10,800	-	-	-	-	
3	24	24,000	6 + 6 + 12	6,000	6,000	12,000	-	-	-	-	-
		28,800		7,200	7,200	14,400	-	-	-	-	
3	27	27,000	6 + 6 + 15	6,000	6,000	15,000	-	-	-	-	-
		32,800		7,300	7,300	18,200	-	-	-	-	
3	30	30,000	6 + 6 + 18	6,000	6,000	18,000	-	-	-	-	-
		36,900		7,400	7,400	22,100	-	-	-	-	
3	36	36,000	6 + 6 + 24	6,000	6,000	24,000	-	-	-	-	-
		45,000		7,500	7,500	30,000	-	-	-	-	
3	42	42,000	6 + 6 + 30	6,000	6,000	30,000	-	-	-	-	-
		48,000		6,700	6,700	34,500	-	-	-	-	
3	48	48,000	6 + 6 + 36	6,000	6,000	36,000	-	-	-	-	-
		54,000		6,500	6,500	40,900	-	-	-	-	
3	24	24,000	6 + 9 + 9	6,000	9,000	9,000	-	-	-	-	-
		28,800		7,200	10,800	10,800	-	-	-	-	
3	27	27,000	6 + 9 + 12	6,000	9,000	12,000	-	-	-	-	-
		32,800		7,300	10,900	14,600	-	-	-	-	
3	30	30,000	6 + 9 + 15	6,000	9,000	15,000	-	-	-	-	-
		36,900		7,400	11,100	18,500	-	-	-	-	
3	33	33,000	6 + 9 + 18	6,000	9,000	18,000	-	-	-	-	-
		40,900		7,400	11,200	22,300	-	-	-	-	
3	36	36,000	9 + 9 + 18	9,000	9,000	18,000	-	-	-	-	-
		45,000		11,300	11,300	22,500	-	-	-	-	
3	39	39,000	6 + 9 + 24	6,000	9,000	24,000	-	-	-	-	-
		46,500		7,200	10,700	28,600	-	-	-	-	
3	45	45,000	6 + 9 + 30	6,000	9,000	30,000	-	-	-	-	-
		51,000		6,700	10,000	34,300	-	-	-	-	
3	51	48,000	6 + 9 + 36	5,600	8,500	33,900	-	-	-	-	-
		54,000		6,200	9,300	38,600	-	-	-	-	
3	30	30,000	6 + 12 + 12	6,000	12,000	12,000	-	-	-	-	-
		36,900		7,400	14,800	14,800	-	-	-	-	
3	33	33,000	6 + 12 + 15	6,000	12,000	15,000	-	-	-	-	-
		40,900		7,400	14,900	18,600	-	-	-	-	
3	36	36,000	6 + 12 + 18	6,000	12,000	18,000	-	-	-	-	-
		45,000		7,500	15,000	22,500	-	-	-	-	
3	42	42,000	6 + 12 + 24	6,000	12,000	24,000	-	-	-	-	-
		48,000		6,900	13,700	27,400	-	-	-	-	

MXZ-8C48NA OPERATIONAL PERFORMANCE, CONTD.

NON-DUCTED:

# of Indoor Unit	Total Nominal Capacity (x1000 Btu/h)	Total Indoor Unit Capacity (Btu/h)	Operational Performance for Indoor Unit Combinations (Unit A + Unit B + Unit C + Unit D + Unit E + Unit F + Unit G + Unit H)	Cooling Capacity Range (Btu/h)							
				Heating Capacity Range (Btu/h)							
				Unit A	Unit B	Unit C	Unit D	Unit E	Unit F	Unit G	Unit H
3	48	48,000	6 + 12 + 30	6,000	12,000	30,000	-	-	-	-	-
		54,000		6,600	13,300	34,100	-	-	-	-	
3	54	48,000	6 + 12 + 36	5,300	10,700	32,000	-	-	-	-	-
		54,000		5,800	11,700	36,500	-	-	-	-	
3	36	36,000	6 + 15 + 15	6,000	15,000	15,000	-	-	-	-	-
		45,000		7,500	18,800	18,800	-	-	-	-	
3	39	39,000	6 + 15 + 18	6,000	15,000	18,000	-	-	-	-	-
		46,500		7,200	17,900	21,500	-	-	-	-	
3	45	45,000	6 + 15 + 24	6,000	15,000	24,000	-	-	-	-	-
		51,000		6,800	17,000	27,200	-	-	-	-	
3	51	48,000	6 + 15 + 30	-	14,100	28,200	-	-	-	-	-
		54,000		6,300	15,700	32,100	-	-	-	-	
3	57	48,000	6 + 15 + 36	-	12,600	30,300	-	-	-	-	-
		54,000		5,500	13,800	34,600	-	-	-	-	
3	42	42,000	6 + 18 + 18	6,000	18,000	18,000	-	-	-	-	-
		48,000		6,900	20,600	20,600	-	-	-	-	
3	48	48,000	6 + 18 + 24	-	18,000	24,000	-	-	-	-	-
		54,000		6,800	20,300	27,000	-	-	-	-	
3	54	48,000	6 + 18 + 30	5,300	16,000	26,700	-	-	-	-	-
		54,000		5,900	17,800	30,300	-	-	-	-	
3	60	48,000	6 + 18 + 36	4,800	14,400	28,800	-	-	-	-	-
		54,000		5,300	15,800	32,900	-	-	-	-	
3	54	48,000	6 + 24 + 24	-	21,300	21,300	-	-	-	-	-
		54,000		6,000	24,000	24,000	-	-	-	-	
3	60	48,000	6 + 24 + 30	-	19,200	24,000	-	-	-	-	-
		54,000		5,300	21,300	27,300	-	-	-	-	
3	27	27,000	9 + 9 + 9	9,000	9,000	9,000	-	-	-	-	-
		32,800		10,900	10,900	10,900	-	-	-	-	
3	30	30,000	9 + 9 + 12	9,000	9,000	12,000	-	-	-	-	-
		36,900		11,100	11,100	14,800	-	-	-	-	
3	33	33,000	9 + 9 + 15	9,000	9,000	15,000	-	-	-	-	-
		40,900		11,200	11,200	18,600	-	-	-	-	
3	36	36,000	9 + 9 + 18	-	9,000	18,000	-	-	-	-	-
		45,000		11,300	11,300	22,500	-	-	-	-	
3	42	42,000	9 + 9 + 24	9,000	9,000	24,000	-	-	-	-	-
		48,000		10,300	10,300	27,400	-	-	-	-	
3	48	48,000	9 + 9 + 30	9,000	9,000	30,000	-	-	-	-	-
		54,000		10,000	10,000	34,100	-	-	-	-	
3	54	48,000	9 + 9 + 36	8,000	8,000	32,000	-	-	-	-	-
		54,000		8,800	8,800	36,500	-	-	-	-	
3	33	33,000	9 + 12 + 12	9,000	12,000	12,000	-	-	-	-	-
		40,900		11,200	14,900	14,900	-	-	-	-	
3	36	36,000	9 + 12 + 15	9,000	12,000	15,000	-	-	-	-	-
		45,000		11,300	15,000	18,800	-	-	-	-	
3	39	39,000	9 + 12 + 18	9,000	12,000	18,000	-	-	-	-	-
		46,500		10,700	14,300	21,500	-	-	-	-	
3	45	45,000	9 + 12 + 24	9,000	12,000	24,000	-	-	-	-	-
		51,000		10,200	13,600	27,200	-	-	-	-	
3	51	48,000	9 + 12 + 30	8,500	11,300	28,200	-	-	-	-	-
		54,000		9,400	12,500	32,100	-	-	-	-	
3	57	48,000	9 + 12 + 36	7,600	10,100	30,300	-	-	-	-	-
		54,000		8,300	11,100	34,600	-	-	-	-	
3	39	39,000	9 + 15 + 15	9,000	15,000	15,000	-	-	-	-	-
		46,500		10,700	17,900	17,900	-	-	-	-	
3	42	42,000	9 + 15 + 18	9,000	15,000	18,000	-	-	-	-	-
		48,000		10,300	17,100	20,600	-	-	-	-	
3	48	48,000	9 + 15 + 24	9,000	15,000	24,000	-	-	-	-	-
		54,000		10,100	16,900	27,000	-	-	-	-	
3	54	48,000	9 + 15 + 30	8,000	13,300	26,700	-	-	-	-	-
		54,000		8,900	14,800	30,300	-	-	-	-	
3	60	48,000	9 + 15 + 36	7,200	12,000	28,800	-	-	-	-	-
		54,000		7,900	13,200	32,900	-	-	-	-	

MXZ-8C48NA OPERATIONAL PERFORMANCE, CONTD.

NON-DUCTED:

# of Indoor Unit	Total Nominal Capacity (x1000 Btu/h)	Total Indoor Unit Capacity (Btu/h)	Operational Performance for Indoor Unit Combinations (Unit A + Unit B + Unit C + Unit D + Unit E + Unit F + Unit G + Unit H)	Cooling Capacity Range (Btu/h)							
				Heating Capacity Range (Btu/h)							
				Unit A	Unit B	Unit C	Unit D	Unit E	Unit F	Unit G	Unit H
3	45	45,000	9 + 18 + 18	9,000	18,000	18,000	-	-	-	-	-
		51,000		10,200	20,400	20,400	-	-	-	-	-
3	51	48,000	9 + 18 + 24	8,500	16,900	22,600	-	-	-	-	-
		54,000		9,500	19,100	25,400	-	-	-	-	-
3	57	48,000	9 + 18 + 30	7,600	15,200	25,300	-	-	-	-	-
		54,000		8,400	16,800	28,800	-	-	-	-	-
3	57	48,000	9 + 24 + 24	7,600	20,200	20,200	-	-	-	-	-
		54,000		8,500	22,700	22,700	-	-	-	-	-
3	36	36,000	12 + 12 + 12	12,000	12,000	12,000	-	-	-	-	-
		45,000		15,000	15,000	15,000	-	-	-	-	-
3	39	39,000	12 + 12 + 15	12,000	12,000	15,000	-	-	-	-	-
		46,500		14,300	14,300	17,900	-	-	-	-	-
3	42	42,000	12 + 12 + 18	12,000	12,000	18,000	-	-	-	-	-
		48,000		13,700	13,700	20,600	-	-	-	-	-
3	48	48,000	12 + 12 + 24	12,000	12,000	24,000	-	-	-	-	-
		54,000		13,500	13,500	27,000	-	-	-	-	-
3	54	48,000	12 + 12 + 30	10,700	10,700	26,700	-	-	-	-	-
		54,000		11,800	11,800	30,300	-	-	-	-	-
3	60	48,000	12 + 12 + 36	9,600	9,600	28,800	-	-	-	-	-
		54,000		10,500	10,500	32,900	-	-	-	-	-
3	42	42,000	12 + 15 + 15	12,000	15,000	15,000	-	-	-	-	-
		48,000		13,700	17,100	17,100	-	-	-	-	-
3	45	45,000	12 + 15 + 18	12,000	15,000	18,000	-	-	-	-	-
		51,000		13,600	17,000	20,400	-	-	-	-	-
3	51	48,000	12 + 15 + 24	11,300	14,100	22,600	-	-	-	-	-
		54,000		12,700	15,900	25,400	-	-	-	-	-
3	57	48,000	12 + 15 + 30	10,100	12,600	25,300	-	-	-	-	-
		54,000		11,200	14,000	28,800	-	-	-	-	-
3	48	48,000	12 + 18 + 18	12,000	18,000	18,000	-	-	-	-	-
		54,000		13,500	20,300	20,300	-	-	-	-	-
3	54	48,000	12 + 18 + 24	10,700	16,000	21,300	-	-	-	-	-
		54,000		12,000	18,000	24,000	-	-	-	-	-
3	60	48,000	12 + 18 + 30	9,600	14,400	24,000	-	-	-	-	-
		54,000		10,700	16,000	27,300	-	-	-	-	-
3	60	48,000	12 + 24 + 24	9,600	19,200	19,200	-	-	-	-	-
		54,000		10,800	21,600	21,600	-	-	-	-	-
3	45	45,000	15 + 15 + 15	15,000	15,000	15,000	-	-	-	-	-
		51,000		17,000	17,000	17,000	-	-	-	-	-
3	48	48,000	15 + 15 + 18	15,000	15,000	18,000	-	-	-	-	-
		54,000		16,900	16,900	20,300	-	-	-	-	-
3	54	48,000	15 + 15 + 24	13,300	13,300	21,300	-	-	-	-	-
		54,000		15,000	15,000	24,000	-	-	-	-	-
3	60	48,000	15 + 15 + 30	12,000	12,000	24,000	-	-	-	-	-
		54,000		13,300	13,300	27,300	-	-	-	-	-
3	51	48,000	15 + 18 + 18	14,100	16,900	16,900	-	-	-	-	-
		54,000		15,900	19,100	19,100	-	-	-	-	-
3	60	48,000	18 + 18 + 24	14,400	14,400	19,200	-	-	-	-	-
		54,000		16,200	16,200	21,600	-	-	-	-	-
4	24	24,000	6 + 6 + 6 + 6	6,000	6,000	6,000	6,000	-	-	-	-
		28,800		7,200	7,200	7,200	7,200	-	-	-	-
4	27	27,000	6 + 6 + 6 + 9	6,000	6,000	6,000	9,000	-	-	-	-
		32,800		7,300	7,300	7,300	10,900	-	-	-	-
4	30	30,000	6 + 6 + 6 + 12	6,000	6,000	6,000	12,000	-	-	-	-
		36,900		7,400	7,400	7,400	14,800	-	-	-	-
4	33	33,000	6 + 6 + 6 + 15	6,000	6,000	6,000	15,000	-	-	-	-
		40,900		7,400	7,400	7,400	18,600	-	-	-	-
4	36	36,000	6 + 6 + 6 + 18	6,000	6,000	6,000	18,000	-	-	-	-
		45,000		7,500	7,500	7,500	22,500	-	-	-	-
4	42	42,000	6 + 6 + 6 + 24	6,000	6,000	6,000	24,000	-	-	-	-
		48,000		6,900	6,900	6,900	27,400	-	-	-	-
4	48	48,000	6 + 6 + 6 + 30	6,000	6,000	6,000	30,000	-	-	-	-
		54,000		6,600	6,600	6,600	34,100	-	-	-	-

MXZ-8C48NA OPERATIONAL PERFORMANCE, CONTD.

NON-DUCTED:

# of Indoor Unit	Total Nominal Capacity (x1000 Btu/h)	Total Indoor Unit Capacity (Btu/h)	Operational Performance for Indoor Unit Combinations (Unit A + Unit B + Unit C + Unit D + Unit E + Unit F + Unit G + Unit H)	Cooling Capacity Range (Btu/h)							
				Heating Capacity Range (Btu/h)							
				Unit A	Unit B	Unit C	Unit D	Unit E	Unit F	Unit G	Unit H
4	54	48,000	6 + 6 + 6 + 36	5,300	5,300	5,300	32,000	-	-	-	-
		54,000		5,800	5,800	5,800	36,500	-	-	-	-
4	30	30,000	6 + 6 + 9 + 9	6,000	6,000	9,000	9,000	-	-	-	-
		36,900		7,400	7,400	11,100	11,100	-	-	-	-
4	33	33,000	6 + 6 + 9 + 12	6,000	6,000	9,000	12,000	-	-	-	-
		40,900		7,400	7,400	11,200	14,900	-	-	-	-
4	36	36,000	6 + 6 + 9 + 15	6,000	6,000	9,000	15,000	-	-	-	-
		45,000		7,500	7,500	11,300	18,800	-	-	-	-
4	39	39,000	6 + 6 + 9 + 18	6,000	6,000	9,000	18,000	-	-	-	-
		46,500		7,200	7,200	10,700	21,500	-	-	-	-
4	45	45,000	6 + 6 + 9 + 24	6,000	6,000	9,000	24,000	-	-	-	-
		51,000		6,800	6,800	10,200	27,200	-	-	-	-
4	51	48,000	6 + 6 + 9 + 30	5,600	5,600	8,500	28,200	-	-	-	-
		54,000		6,300	6,300	9,400	32,100	-	-	-	-
4	57	48,000	6 + 6 + 9 + 36	5,100	5,100	7,600	30,300	-	-	-	-
		54,000		5,500	5,500	8,300	34,600	-	-	-	-
4	36	36,000	6 + 6 + 12 + 12	6,000	6,000	12,000	12,000	-	-	-	-
		45,000		7,500	7,500	15,000	15,000	-	-	-	-
4	39	39,000	6 + 6 + 12 + 15	6,000	6,000	12,000	15,000	-	-	-	-
		46,500		7,200	7,200	14,300	17,900	-	-	-	-
4	42	42,000	6 + 6 + 12 + 18	6,000	6,000	12,000	18,000	-	-	-	-
		48,000		6,900	6,900	13,700	20,600	-	-	-	-
4	48	48,000	6 + 6 + 12 + 24	6,000	6,000	12,000	24,000	-	-	-	-
		54,000		6,800	6,800	13,500	27,000	-	-	-	-
4	54	48,000	6 + 6 + 12 + 30	5,300	5,300	10,700	26,700	-	-	-	-
		54,000		5,900	5,900	11,800	30,300	-	-	-	-
4	60	48,000	6 + 6 + 12 + 36	4,800	4,800	9,600	28,800	-	-	-	-
		54,000		5,300	5,300	10,500	32,900	-	-	-	-
4	42	42,000	6 + 6 + 15 + 15	6,000	6,000	15,000	15,000	-	-	-	-
		48,000		6,900	6,900	17,100	17,100	-	-	-	-
4	45	45,000	6 + 6 + 15 + 18	6,000	6,000	15,000	18,000	-	-	-	-
		51,000		6,800	6,800	17,000	20,400	-	-	-	-
4	51	48,000	6 + 6 + 15 + 24	5,600	5,600	14,100	22,600	-	-	-	-
		54,000		6,400	6,400	15,900	25,400	-	-	-	-
4	57	48,000	6 + 6 + 15 + 30	5,100	5,100	12,600	25,300	-	-	-	-
		54,000		5,600	5,600	14,000	28,800	-	-	-	-
4	48	48,000	6 + 6 + 18 + 18	6,000	6,000	18,000	18,000	-	-	-	-
		54,000		6,800	6,800	20,300	20,300	-	-	-	-
4	54	48,000	6 + 6 + 18 + 24	5,300	5,300	16,000	21,300	-	-	-	-
		54,000		6,000	6,000	18,000	24,000	-	-	-	-
4	60	48,000	6 + 6 + 18 + 30	4,800	4,800	14,400	24,000	-	-	-	-
		54,000		5,300	5,300	16,000	27,300	-	-	-	-
4	60	48,000	6 + 6 + 24 + 24	4,800	4,800	19,200	19,200	-	-	-	-
		54,000		5,400	5,400	21,600	21,600	-	-	-	-
4	33	33,000	6 + 9 + 9 + 9	6,000	9,000	9,000	9,000	-	-	-	-
		40,900		7,400	11,200	11,200	11,200	-	-	-	-
4	36	36,000	6 + 9 + 9 + 12	6,000	9,000	9,000	12,000	-	-	-	-
		45,000		7,500	11,300	11,300	15,000	-	-	-	-
4	39	39,000	6 + 9 + 9 + 15	6,000	9,000	9,000	15,000	-	-	-	-
		46,500		7,200	10,700	10,700	17,900	-	-	-	-
4	42	42,000	6 + 9 + 9 + 18	6,000	9,000	9,000	18,000	-	-	-	-
		48,000		6,900	10,300	10,300	20,600	-	-	-	-
4	48	48,000	6 + 9 + 9 + 24	6,000	9,000	9,000	24,000	-	-	-	-
		54,000		6,800	10,100	10,100	27,000	-	-	-	-
4	54	48,000	6 + 9 + 9 + 30	5,300	8,000	8,000	26,700	-	-	-	-
		54,000		5,900	8,900	8,900	30,300	-	-	-	-
4	60	48,000	6 + 9 + 9 + 36	4,800	7,200	7,200	28,800	-	-	-	-
		54,000		5,300	7,900	7,900	32,900	-	-	-	-
4	39	39,000	6 + 9 + 12 + 12	6,000	9,000	12,000	12,000	-	-	-	-
		46,500		7,200	10,700	14,300	14,300	-	-	-	-
4	42	42,000	6 + 9 + 12 + 15	6,000	9,000	12,000	15,000	-	-	-	-
		48,000		6,900	10,300	13,700	17,100	-	-	-	-

MXZ-8C48NA OPERATIONAL PERFORMANCE, CONTD.

NON-DUCTED:

# of Indoor Unit	Total Nominal Capacity (x1000 Btu/h)	Total Indoor Unit Capacity (Btu/h)	Operational Performance for Indoor Unit Combinations (Unit A + Unit B + Unit C + Unit D + Unit E + Unit F + Unit G + Unit H)	Cooling Capacity Range (Btu/h)							
				Heating Capacity Range (Btu/h)							
				Unit A	Unit B	Unit C	Unit D	Unit E	Unit F	Unit G	Unit H
4	45	45,000	6 + 9 + 12 + 18	6,000	9,000	12,000	18,000	-	-	-	-
		51,000		6,800	10,200	13,600	20,400	-	-	-	-
4	51	48,000	6 + 9 + 12 + 24	5,600	8,500	11,300	22,600	-	-	-	-
		54,000		6,400	9,500	12,700	25,400	-	-	-	-
4	57	48,000	6 + 9 + 12 + 30	5,100	7,600	10,100	25,300	-	-	-	-
		54,000		5,600	8,400	11,200	28,800	-	-	-	-
4	45	45,000	6 + 9 + 15 + 15	6,000	9,000	15,000	15,000	-	-	-	-
		51,000		6,800	10,200	17,000	17,000	-	-	-	-
4	48	48,000	6 + 9 + 15 + 18	6,000	9,000	15,000	18,000	-	-	-	-
		54,000		6,800	10,100	16,900	20,300	-	-	-	-
4	54	48,000	6 + 9 + 15 + 24	5,300	8,000	13,300	21,300	-	-	-	-
		54,000		6,000	9,000	15,000	24,000	-	-	-	-
4	60	48,000	6 + 9 + 15 + 30	4,800	7,200	12,000	24,000	-	-	-	-
		54,000		5,300	8,000	13,300	27,300	-	-	-	-
4	51	48,000	6 + 9 + 18 + 18	5,600	8,500	16,900	16,900	-	-	-	-
		54,000		6,400	9,500	19,100	19,100	-	-	-	-
4	57	48,000	6 + 9 + 18 + 24	5,100	7,600	15,200	20,200	-	-	-	-
		54,000		5,700	8,500	17,100	22,700	-	-	-	-
4	42	42,000	6 + 12 + 12 + 12	6,000	12,000	12,000	12,000	-	-	-	-
		48,000		6,900	13,700	13,700	13,700	-	-	-	-
4	45	45,000	6 + 12 + 12 + 15	6,000	12,000	12,000	15,000	-	-	-	-
		51,000		6,800	13,600	13,600	17,000	-	-	-	-
4	48	48,000	6 + 12 + 12 + 18	6,000	12,000	12,000	18,000	-	-	-	-
		54,000		6,800	13,500	13,500	20,300	-	-	-	-
4	54	48,000	6 + 12 + 12 + 24	5,300	10,700	10,700	21,300	-	-	-	-
		54,000		6,000	12,000	12,000	24,000	-	-	-	-
4	60	48,000	6 + 12 + 12 + 30	4,800	9,600	9,600	24,000	-	-	-	-
		54,000		5,300	10,700	10,700	27,300	-	-	-	-
4	48	48,000	6 + 12 + 15 + 15	6,000	12,000	15,000	15,000	-	-	-	-
		54,000		6,800	13,500	16,900	16,900	-	-	-	-
4	51	48,000	6 + 12 + 15 + 18	5,600	11,300	14,100	16,900	-	-	-	-
		54,000		6,400	12,700	15,900	19,100	-	-	-	-
4	57	48,000	6 + 12 + 15 + 24	5,100	10,100	12,600	20,200	-	-	-	-
		54,000		5,700	11,400	14,200	22,700	-	-	-	-
4	51	48,000	6 + 15 + 15 + 15	5,600	14,100	14,100	14,100	-	-	-	-
		54,000		6,400	15,900	15,900	15,900	-	-	-	-
4	54	48,000	6 + 15 + 15 + 18	5,300	13,300	13,300	16,000	-	-	-	-
		54,000		6,000	15,000	15,000	18,000	-	-	-	-
4	60	48,000	6 + 15 + 15 + 24	4,800	12,000	12,000	19,200	-	-	-	-
		54,000		5,400	13,500	13,500	21,600	-	-	-	-
4	60	48,000	6 + 18 + 18 + 18	4,800	14,400	14,400	14,400	-	-	-	-
		54,000		5,400	16,200	16,200	16,200	-	-	-	-
4	36	36,000	9 + 9 + 9 + 9	9,000	9,000	9,000	9,000	-	-	-	-
		45,000		11,300	11,300	11,300	11,300	-	-	-	-
4	39	39,000	9 + 9 + 9 + 12	9,000	9,000	9,000	12,000	-	-	-	-
		46,500		10,700	10,700	10,700	14,300	-	-	-	-
4	42	42,000	9 + 9 + 9 + 15	9,000	9,000	9,000	15,000	-	-	-	-
		48,000		10,300	10,300	10,300	17,100	-	-	-	-
4	45	45,000	9 + 9 + 9 + 18	9,000	9,000	9,000	18,000	-	-	-	-
		51,000		10,200	10,200	10,200	20,400	-	-	-	-
4	51	48,000	9 + 9 + 9 + 24	8,500	8,500	8,500	22,600	-	-	-	-
		54,000		9,500	9,500	9,500	25,400	-	-	-	-
4	57	48,000	9 + 9 + 9 + 30	7,600	7,600	7,600	25,300	-	-	-	-
		54,000		8,400	8,400	8,400	28,800	-	-	-	-
4	42	42,000	9 + 9 + 12 + 12	9,000	9,000	12,000	12,000	-	-	-	-
		48,000		10,300	10,300	13,700	13,700	-	-	-	-
4	45	45,000	9 + 9 + 12 + 15	9,000	9,000	12,000	15,000	-	-	-	-
		51,000		10,200	10,200	13,600	17,000	-	-	-	-
4	48	48,000	9 + 9 + 12 + 18	9,000	9,000	12,000	18,000	-	-	-	-
		54,000		10,100	10,100	13,500	20,300	-	-	-	-
4	54	48,000	9 + 9 + 12 + 24	8,000	8,000	10,700	21,300	-	-	-	-
		54,000		9,000	9,000	12,000	24,000	-	-	-	-

MXZ-8C48NA OPERATIONAL PERFORMANCE, CONTD.

NON-DUCTED:

# of Indoor Unit	Total Nominal Capacity (x1000 Btu/h)	Total Indoor Unit Capacity (Btu/h)	Operational Performance for Indoor Unit Combinations (Unit A + Unit B + Unit C + Unit D + Unit E + Unit F + Unit G + Unit H)	Cooling Capacity Range (Btu/h)							
				Heating Capacity Range (Btu/h)							
				Unit A	Unit B	Unit C	Unit D	Unit E	Unit F	Unit G	Unit H
4	60	48,000	9 + 9 + 12 + 30	7,200	7,200	9,600	24,000	-	-	-	-
		54,000		8,000	8,000	10,700	27,300	-	-	-	-
4	48	45,000	9 + 9 + 15 + 15	8,400	8,400	14,100	14,100	-	-	-	-
		51,000		9,600	9,600	15,900	15,900	-	-	-	-
4	51	48,000	9 + 9 + 15 + 18	8,500	8,500	14,100	16,900	-	-	-	-
		54,000		9,500	9,500	15,900	19,100	-	-	-	-
4	57	48,000	9 + 9 + 15 + 24	7,600	7,600	12,600	20,200	-	-	-	-
		54,000		8,500	8,500	14,200	22,700	-	-	-	-
4	54	48,000	9 + 9 + 18 + 18	8,000	8,000	16,000	16,000	-	-	-	-
		54,000		9,000	9,000	18,000	18,000	-	-	-	-
4	60	48,000	9 + 9 + 18 + 24	7,200	7,200	14,400	19,200	-	-	-	-
		54,000		8,100	8,100	16,200	21,600	-	-	-	-
4	45	48,000	9 + 12 + 12 + 12	9,600	12,800	12,800	12,800	-	-	-	-
		54,000		10,800	14,400	14,400	14,400	-	-	-	-
4	48	48,000	9 + 12 + 12 + 15	9,000	12,000	12,000	15,000	-	-	-	-
		54,000		10,100	13,500	13,500	16,900	-	-	-	-
4	51	48,000	9 + 12 + 12 + 18	8,500	11,300	11,300	16,900	-	-	-	-
		54,000		9,500	12,700	12,700	19,100	-	-	-	-
4	57	48,000	9 + 12 + 12 + 24	7,600	10,100	10,100	20,200	-	-	-	-
		54,000		8,500	11,400	11,400	22,700	-	-	-	-
4	51	48,000	9 + 12 + 15 + 15	8,500	11,300	14,100	14,100	-	-	-	-
		54,000		9,500	12,700	15,900	15,900	-	-	-	-
4	54	48,000	9 + 12 + 15 + 18	8,000	10,700	13,300	16,000	-	-	-	-
		54,000		9,000	12,000	15,000	18,000	-	-	-	-
4	60	48,000	9 + 12 + 15 + 24	7,200	9,600	12,000	19,200	-	-	-	-
		54,000		8,100	10,800	13,500	21,600	-	-	-	-
4	57	48,000	9 + 12 + 18 + 18	7,600	10,100	15,200	15,200	-	-	-	-
		54,000		8,500	11,400	17,100	17,100	-	-	-	-
4	54	48,000	9 + 15 + 15 + 15	8,000	13,300	13,300	13,300	-	-	-	-
		54,000		9,000	15,000	15,000	15,000	-	-	-	-
4	57	48,000	9 + 15 + 15 + 18	7,600	12,600	12,600	15,200	-	-	-	-
		54,000		8,500	14,200	14,200	17,100	-	-	-	-
4	60	48,000	9 + 15 + 18 + 18	7,200	12,000	14,400	14,400	-	-	-	-
		54,000		8,100	13,500	16,200	16,200	-	-	-	-
4	48	48,000	12 + 12 + 12 + 12	12,000	12,000	12,000	12,000	-	-	-	-
		54,000		13,500	13,500	13,500	13,500	-	-	-	-
4	51	48,000	12 + 12 + 12 + 15	11,300	11,300	11,300	14,100	-	-	-	-
		54,000		12,700	12,700	12,700	15,900	-	-	-	-
4	54	48,000	12 + 12 + 12 + 18	10,700	10,700	10,700	16,000	-	-	-	-
		54,000		12,000	12,000	12,000	18,000	-	-	-	-
4	60	48,000	12 + 12 + 12 + 24	9,600	9,600	9,600	19,200	-	-	-	-
		54,000		10,800	10,800	10,800	21,600	-	-	-	-
4	54	48,000	12 + 12 + 15 + 15	10,700	10,700	13,300	13,300	-	-	-	-
		54,000		12,000	12,000	15,000	15,000	-	-	-	-
4	57	48,000	12 + 12 + 15 + 18	10,100	10,100	12,600	15,200	-	-	-	-
		54,000		11,400	11,400	14,200	17,100	-	-	-	-
4	60	48,000	12 + 12 + 18 + 18	9,600	9,600	14,400	14,400	-	-	-	-
		54,000		10,800	10,800	16,200	16,200	-	-	-	-
4	57	48,000	12 + 15 + 15 + 15	10,100	12,600	12,600	12,600	-	-	-	-
		54,000		11,400	14,200	14,200	14,200	-	-	-	-
4	60	48,000	12 + 15 + 15 + 18	9,600	12,000	12,000	14,400	-	-	-	-
		54,000		10,800	13,500	13,500	16,200	-	-	-	-
4	60	48,000	15 + 15 + 15 + 15	12,000	12,000	12,000	12,000	-	-	-	-
		54,000		13,500	13,500	13,500	13,500	-	-	-	-
5	30	30,000	6 + 6 + 6 + 6 + 6	6,000	6,000	6,000	6,000	6,000	-	-	-
		36,900		7,400	7,400	7,400	7,400	7,400	-	-	-
5	33	33,000	6 + 6 + 6 + 6 + 9	6,000	6,000	6,000	6,000	9,000	-	-	-
		40,900		7,400	7,400	7,400	7,400	11,200	-	-	-
5	36	36,000	6 + 6 + 6 + 6 + 12	6,000	6,000	6,000	6,000	12,000	-	-	-
		45,000		7,500	7,500	7,500	7,500	15,000	-	-	-
5	39	39,000	6 + 6 + 6 + 6 + 15	6,000	6,000	6,000	6,000	15,000	-	-	-
		46,500		7,200	7,200	7,200	7,200	17,900	-	-	-

MXZ-8C48NA OPERATIONAL PERFORMANCE, CONTD.

NON-DUCTED:

# of Indoor Unit	Total Nominal Capacity (x1000 Btu/h)	Total Indoor Unit Capacity (Btu/h)	Operational Performance for Indoor Unit Combinations (Unit A + Unit B + Unit C + Unit D + Unit E + Unit F + Unit G + Unit H)	Cooling Capacity Range (Btu/h)							
				Heating Capacity Range (Btu/h)							
				Unit A	Unit B	Unit C	Unit D	Unit E	Unit F	Unit G	Unit H
5	42	42,000	6 + 6 + 6 + 6 + 18	6,000	6,000	6,000	6,000	18,000	-	-	-
		48,000		6,900	6,900	6,900	6,900	20,600	-	-	-
5	48	48,000	6 + 6 + 6 + 6 + 24	6,000	6,000	6,000	6,000	24,000	-	-	-
		54,000		6,800	6,800	6,800	6,800	27,000	-	-	-
5	54	48,000	6 + 6 + 6 + 6 + 30	5,300	5,300	5,300	5,300	26,700	-	-	-
		54,000		5,900	5,900	5,900	5,900	30,300	-	-	-
5	60	48,000	6 + 6 + 6 + 6 + 36	4,800	4,800	4,800	4,800	28,800	-	-	-
		54,000		5,300	5,300	5,300	5,300	32,900	-	-	-
5	36	36,000	6 + 6 + 6 + 9 + 9	6,000	6,000	6,000	9,000	9,000	-	-	-
		45,000		7,500	7,500	7,500	11,300	11,300	-	-	-
5	39	39,000	6 + 6 + 6 + 9 + 12	6,000	6,000	6,000	9,000	12,000	-	-	-
		46,500		7,200	7,200	7,200	10,700	14,300	-	-	-
5	42	42,000	6 + 6 + 6 + 9 + 15	6,000	6,000	6,000	9,000	15,000	-	-	-
		48,000		6,900	6,900	6,900	10,300	17,100	-	-	-
5	45	45,000	6 + 6 + 6 + 9 + 18	6,000	6,000	6,000	9,000	18,000	-	-	-
		51,000		6,800	6,800	6,800	10,200	20,400	-	-	-
5	51	48,000	6 + 6 + 6 + 9 + 24	5,600	5,600	5,600	8,500	22,600	-	-	-
		54,000		6,400	6,400	6,400	9,500	25,400	-	-	-
5	57	48,000	6 + 6 + 6 + 9 + 30	5,100	5,100	5,100	7,600	25,300	-	-	-
		54,000		5,600	5,600	5,600	8,400	28,800	-	-	-
5	42	42,000	6 + 6 + 6 + 12 + 12	6,000	6,000	6,000	12,000	12,000	-	-	-
		48,000		6,900	6,900	6,900	13,700	13,700	-	-	-
5	45	45,000	6 + 6 + 6 + 12 + 15	6,000	6,000	6,000	12,000	15,000	-	-	-
		51,000		6,800	6,800	6,800	13,600	17,000	-	-	-
5	48	48,000	6 + 6 + 6 + 12 + 18	6,000	6,000	6,000	12,000	18,000	-	-	-
		54,000		6,800	6,800	6,800	13,500	20,300	-	-	-
5	54	48,000	6 + 6 + 6 + 12 + 24	5,300	5,300	5,300	10,700	21,300	-	-	-
		54,000		6,000	6,000	6,000	12,000	24,000	-	-	-
5	60	48,000	6 + 6 + 6 + 12 + 30	4,800	4,800	4,800	9,600	24,000	-	-	-
		54,000		5,300	5,300	5,300	10,700	27,300	-	-	-
5	48	48,000	6 + 6 + 6 + 15 + 15	6,000	6,000	6,000	15,000	15,000	-	-	-
		54,000		6,800	6,800	6,800	16,900	16,900	-	-	-
5	51	48,000	6 + 6 + 6 + 15 + 18	5,600	5,600	5,600	14,100	16,900	-	-	-
		54,000		6,400	6,400	6,400	15,900	19,100	-	-	-
5	57	48,000	6 + 6 + 6 + 15 + 24	5,100	5,100	5,100	12,600	20,200	-	-	-
		54,000		5,700	5,700	5,700	14,200	22,700	-	-	-
5	54	48,000	6 + 6 + 6 + 18 + 18	5,300	5,300	5,300	16,000	16,000	-	-	-
		54,000		6,000	6,000	6,000	18,000	18,000	-	-	-
5	60	48,000	6 + 6 + 6 + 18 + 24	4,800	4,800	4,800	14,400	19,200	-	-	-
		54,000		5,400	5,400	5,400	16,200	21,600	-	-	-
5	39	39,000	6 + 6 + 9 + 9 + 9	6,000	6,000	9,000	9,000	9,000	-	-	-
		46,500		7,200	7,200	10,700	10,700	10,700	-	-	-
5	42	42,000	6 + 6 + 9 + 9 + 12	6,000	6,000	9,000	9,000	12,000	-	-	-
		48,000		6,900	6,900	10,300	10,300	13,700	-	-	-
5	45	45,000	6 + 6 + 9 + 9 + 15	6,000	6,000	9,000	9,000	15,000	-	-	-
		51,000		6,800	6,800	10,200	10,200	17,000	-	-	-
5	48	48,000	6 + 6 + 9 + 9 + 18	6,000	6,000	9,000	9,000	18,000	-	-	-
		54,000		6,800	6,800	10,100	10,100	20,300	-	-	-
5	54	48,000	6 + 6 + 9 + 9 + 24	5,300	5,300	8,000	8,000	21,300	-	-	-
		54,000		6,000	6,000	9,000	9,000	24,000	-	-	-
5	60	48,000	6 + 6 + 9 + 9 + 30	4,800	4,800	7,200	7,200	24,000	-	-	-
		54,000		5,300	5,300	8,000	8,000	27,300	-	-	-
5	45	45,000	6 + 6 + 9 + 12 + 12	6,000	6,000	9,000	12,000	12,000	-	-	-
		51,000		6,800	6,800	10,200	13,600	13,600	-	-	-
5	48	48,000	6 + 6 + 9 + 12 + 15	6,000	6,000	9,000	12,000	15,000	-	-	-
		54,000		6,800	6,800	10,100	13,500	16,900	-	-	-
5	51	48,000	6 + 6 + 9 + 12 + 18	5,600	5,600	8,500	11,300	16,900	-	-	-
		54,000		6,400	6,400	9,500	12,700	19,100	-	-	-
5	57	48,000	6 + 6 + 9 + 12 + 24	5,100	5,100	7,600	10,100	20,200	-	-	-
		54,000		5,700	5,700	8,500	11,400	22,700	-	-	-
5	51	48,000	6 + 6 + 9 + 15 + 15	5,600	5,600	8,500	14,100	14,100	-	-	-
		54,000		6,400	6,400	9,500	15,900	15,900	-	-	-

MXZ-8C48NA OPERATIONAL PERFORMANCE, CONTD.

NON-DUCTED:

# of Indoor Unit	Total Nominal Capacity (x1000 Btu/h)	Total Indoor Unit Capacity (Btu/h)	Operational Performance for Indoor Unit Combinations (Unit A + Unit B + Unit C + Unit D + Unit E + Unit F + Unit G + Unit H)	Cooling Capacity Range (Btu/h)							
				Heating Capacity Range (Btu/h)							
				Unit A	Unit B	Unit C	Unit D	Unit E	Unit F	Unit G	Unit H
5	54	48,000	6 + 6 + 9 + 15 + 18	5,300	5,300	8,000	13,300	16,000	-	-	-
		54,000		6,000	6,000	9,000	15,000	18,000	-	-	-
5	60	48,000	6 + 6 + 9 + 15 + 24	4,800	4,800	7,200	12,000	19,200	-	-	-
		54,000		5,400	5,400	8,100	13,500	21,600	-	-	-
5	57	48,000	6 + 6 + 9 + 18 + 18	5,100	5,100	7,600	15,200	15,200	-	-	-
		54,000		5,700	5,700	8,500	17,100	17,100	-	-	-
5	48	48,000	6 + 6 + 12 + 12 + 12	6,000	6,000	12,000	12,000	12,000	-	-	-
		54,000		6,800	6,800	13,500	13,500	13,500	-	-	-
5	51	48,000	6 + 6 + 12 + 12 + 15	5,600	5,600	11,300	11,300	14,100	-	-	-
		54,000		6,400	6,400	12,700	12,700	15,900	-	-	-
5	54	48,000	6 + 6 + 12 + 12 + 18	5,300	5,300	10,700	10,700	16,000	-	-	-
		54,000		6,000	6,000	12,000	12,000	18,000	-	-	-
5	60	48,000	6 + 6 + 12 + 12 + 24	4,800	4,800	9,600	9,600	19,200	-	-	-
		54,000		5,400	5,400	10,800	10,800	21,600	-	-	-
5	54	48,000	6 + 6 + 12 + 15 + 15	5,300	5,300	10,700	13,300	13,300	-	-	-
		54,000		6,000	6,000	12,000	15,000	15,000	-	-	-
5	57	48,000	6 + 6 + 12 + 15 + 18	5,100	5,100	10,100	12,600	15,200	-	-	-
		54,000		5,700	5,700	11,400	14,200	17,100	-	-	-
5	60	48,000	6 + 6 + 12 + 18 + 18	4,800	4,800	9,600	14,400	14,400	-	-	-
		54,000		5,400	5,400	10,800	16,200	16,200	-	-	-
5	57	48,000	6 + 6 + 15 + 15 + 15	5,100	5,100	12,600	12,600	12,600	-	-	-
		54,000		5,700	5,700	14,200	14,200	14,200	-	-	-
5	60	48,000	6 + 6 + 15 + 15 + 18	4,800	4,800	12,000	12,000	14,400	-	-	-
		54,000		5,400	5,400	13,500	13,500	16,200	-	-	-
5	42	42,000	6 + 9 + 9 + 9 + 9	6,000	9,000	9,000	9,000	9,000	-	-	-
		48,000		6,900	10,300	10,300	10,300	10,300	-	-	-
5	45	45,000	6 + 9 + 9 + 9 + 12	6,000	9,000	9,000	9,000	12,000	-	-	-
		51,000		6,800	10,200	10,200	10,200	13,600	-	-	-
5	48	48,000	6 + 9 + 9 + 9 + 15	6,000	9,000	9,000	9,000	15,000	-	-	-
		54,000		6,800	10,100	10,100	10,100	16,900	-	-	-
5	51	48,000	6 + 9 + 9 + 9 + 18	5,600	8,500	8,500	8,500	16,900	-	-	-
		54,000		6,400	9,500	9,500	9,500	19,100	-	-	-
5	57	48,000	6 + 9 + 9 + 9 + 24	5,100	7,600	7,600	7,600	20,200	-	-	-
		54,000		5,700	8,500	8,500	8,500	22,700	-	-	-
5	48	48,000	6 + 9 + 9 + 12 + 12	6,000	9,000	9,000	12,000	12,000	-	-	-
		54,000		6,800	10,100	10,100	13,500	13,500	-	-	-
5	51	48,000	6 + 9 + 9 + 12 + 15	5,600	8,500	8,500	11,300	14,100	-	-	-
		54,000		6,400	9,500	9,500	12,700	15,900	-	-	-
5	54	48,000	6 + 9 + 9 + 12 + 18	5,300	8,000	8,000	10,700	16,000	-	-	-
		54,000		6,000	9,000	9,000	12,000	18,000	-	-	-
5	60	48,000	6 + 9 + 9 + 12 + 24	4,800	7,200	7,200	9,600	19,200	-	-	-
		54,000		5,400	8,100	8,100	10,800	21,600	-	-	-
5	54	48,000	6 + 9 + 9 + 15 + 15	5,300	8,000	8,000	13,300	13,300	-	-	-
		54,000		6,000	9,000	9,000	15,000	15,000	-	-	-
5	57	48,000	6 + 9 + 9 + 15 + 18	5,100	7,600	7,600	12,600	15,200	-	-	-
		54,000		5,700	8,500	8,500	14,200	17,100	-	-	-
5	60	48,000	6 + 9 + 9 + 18 + 18	4,800	7,200	7,200	14,400	14,400	-	-	-
		54,000		5,400	8,100	8,100	16,200	16,200	-	-	-
5	51	48,000	6 + 9 + 12 + 12 + 12	5,600	8,500	11,300	11,300	11,300	-	-	-
		54,000		6,400	9,500	12,700	12,700	12,700	-	-	-
5	54	48,000	6 + 9 + 12 + 12 + 15	5,300	8,000	10,700	10,700	13,300	-	-	-
		54,000		6,000	9,000	12,000	12,000	15,000	-	-	-
5	57	48,000	6 + 9 + 12 + 12 + 18	5,100	7,600	10,100	10,100	15,200	-	-	-
		54,000		5,700	8,500	11,400	11,400	17,100	-	-	-
5	57	48,000	6 + 9 + 12 + 15 + 15	5,100	7,600	10,100	12,600	12,600	-	-	-
		54,000		5,700	8,500	11,400	14,200	14,200	-	-	-
5	60	48,000	6 + 9 + 12 + 15 + 18	4,800	7,200	9,600	12,000	14,400	-	-	-
		54,000		5,400	8,100	10,800	13,500	16,200	-	-	-
5	60	48,000	6 + 9 + 15 + 15 + 15	4,800	7,200	12,000	12,000	12,000	-	-	-
		54,000		5,400	8,100	13,500	13,500	13,500	-	-	-
5	54	48,000	6 + 12 + 12 + 12 + 12	5,300	10,700	10,700	10,700	10,700	-	-	-
		54,000		6,000	12,000	12,000	12,000	12,000	-	-	-

MXZ-8C48NA OPERATIONAL PERFORMANCE, CONTD.

NON-DUCTED:

# of Indoor Unit	Total Nominal Capacity (x1000 Btu/h)	Total Indoor Unit Capacity (Btu/h)	Operational Performance for Indoor Unit Combinations (Unit A + Unit B + Unit C + Unit D + Unit E + Unit F + Unit G + Unit H)	Cooling Capacity Range (Btu/h)							
				Heating Capacity Range (Btu/h)							
				Unit A	Unit B	Unit C	Unit D	Unit E	Unit F	Unit G	Unit H
5	57	48,000	6 + 12 + 12 + 12 + 15	5,100	10,100	10,100	10,100	12,600	-	-	-
		54,000		5,700	11,400	11,400	11,400	14,200	-	-	-
5	60	48,000	6 + 12 + 12 + 12 + 18	4,800	9,600	9,600	9,600	14,400	-	-	-
		54,000		5,400	10,800	10,800	10,800	16,200	-	-	-
5	60	48,000	6 + 12 + 12 + 15 + 15	4,800	9,600	9,600	12,000	12,000	-	-	-
		54,000		5,400	10,800	10,800	13,500	13,500	-	-	-
5	45	45,000	9 + 9 + 9 + 9 + 9	9,000	9,000	9,000	9,000	9,000	-	-	-
		51,000		10,200	10,200	10,200	10,200	10,200	-	-	-
5	48	48,000	9 + 9 + 9 + 9 + 12	9,000	9,000	9,000	9,000	12,000	-	-	-
		54,000		10,100	10,100	10,100	13,500	-	-	-	
5	51	48,000	9 + 9 + 9 + 9 + 15	8,500	8,500	8,500	8,500	14,100	-	-	-
		54,000		9,500	9,500	9,500	9,500	15,900	-	-	-
5	54	48,000	9 + 9 + 9 + 9 + 18	8,000	8,000	8,000	8,000	16,000	-	-	-
		54,000		9,000	9,000	9,000	9,000	18,000	-	-	-
5	60	48,000	9 + 9 + 9 + 9 + 24	7,200	7,200	7,200	7,200	19,200	-	-	-
		54,000		8,100	8,100	8,100	8,100	21,600	-	-	-
5	51	48,000	9 + 9 + 9 + 12 + 12	8,500	8,500	8,500	11,300	11,300	-	-	-
		54,000		9,500	9,500	9,500	12,700	12,700	-	-	-
5	54	48,000	9 + 9 + 9 + 12 + 15	8,000	8,000	8,000	10,700	13,300	-	-	-
		54,000		9,000	9,000	9,000	12,000	15,000	-	-	-
5	57	48,000	9 + 9 + 9 + 12 + 18	7,600	7,600	7,600	10,100	15,200	-	-	-
		54,000		8,500	8,500	8,500	11,400	17,100	-	-	-
5	57	48,000	9 + 9 + 9 + 15 + 15	7,600	7,600	7,600	12,600	12,600	-	-	-
		54,000		8,500	8,500	8,500	14,200	14,200	-	-	-
5	60	48,000	9 + 9 + 9 + 15 + 18	7,200	7,200	7,200	12,000	14,400	-	-	-
		54,000		8,100	8,100	8,100	13,500	16,200	-	-	-
5	54	48,000	9 + 9 + 12 + 12 + 12	8,000	8,000	10,700	10,700	10,700	-	-	-
		54,000		9,000	9,000	12,000	12,000	12,000	-	-	-
5	57	48,000	9 + 9 + 12 + 12 + 15	7,600	7,600	10,100	10,100	12,600	-	-	-
		54,000		8,500	8,500	11,400	11,400	14,200	-	-	-
5	60	48,000	9 + 9 + 12 + 12 + 18	7,200	7,200	9,600	9,600	14,400	-	-	-
		54,000		8,100	8,100	10,800	10,800	16,200	-	-	-
5	60	48,000	9 + 9 + 12 + 15 + 15	7,200	7,200	9,600	12,000	12,000	-	-	-
		54,000		8,100	8,100	10,800	13,500	13,500	-	-	-
5	57	48,000	9 + 12 + 12 + 12 + 12	7,600	10,100	10,100	10,100	10,100	-	-	-
		54,000		8,500	11,400	11,400	11,400	11,400	-	-	-
5	60	48,000	9 + 12 + 12 + 12 + 15	7,200	9,600	9,600	9,600	12,000	-	-	-
		54,000		8,100	10,800	10,800	10,800	13,500	-	-	-
5	60	48,000	12 + 12 + 12 + 12 + 12	9,600	9,600	9,600	9,600	9,600	-	-	-
		54,000		10,800	10,800	10,800	10,800	10,800	-	-	-
6	36	36,000	6 + 6 + 6 + 6 + 6 + 6	6,000	6,000	6,000	6,000	6,000	6,000	-	-
		45,000		7,500	7,500	7,500	7,500	7,500	7,500	-	-
6	39	39,000	6 + 6 + 6 + 6 + 6 + 9	6,000	6,000	6,000	6,000	6,000	9,000	-	-
		46,500		7,200	7,200	7,200	7,200	7,200	10,700	-	-
6	42	42,000	6 + 6 + 6 + 6 + 6 + 12	6,000	6,000	6,000	6,000	6,000	12,000	-	-
		48,000		6,900	6,900	6,900	6,900	6,900	13,700	-	-
6	45	45,000	6 + 6 + 6 + 6 + 6 + 15	6,000	6,000	6,000	6,000	6,000	15,000	-	-
		51,000		6,800	6,800	6,800	6,800	6,800	17,000	-	-
6	48	48,000	6 + 6 + 6 + 6 + 6 + 18	6,000	6,000	6,000	6,000	6,000	18,000	-	-
		54,000		6,800	6,800	6,800	6,800	6,800	20,300	-	-
6	54	48,000	6 + 6 + 6 + 6 + 6 + 24	5,300	5,300	5,300	5,300	5,300	21,300	-	-
		54,000		6,000	6,000	6,000	6,000	6,000	24,000	-	-
6	60	48,000	6 + 6 + 6 + 6 + 6 + 30	4,800	4,800	4,800	4,800	4,800	24,000	-	-
		54,000		5,300	5,300	5,300	5,300	5,300	27,300	-	-
6	42	42,000	6 + 6 + 6 + 6 + 9 + 9	6,000	6,000	6,000	6,000	9,000	9,000	-	-
		48,000		6,900	6,900	6,900	6,900	10,300	10,300	-	-
6	45	45,000	6 + 6 + 6 + 6 + 9 + 12	6,000	6,000	6,000	6,000	9,000	12,000	-	-
		51,000		6,800	6,800	6,800	6,800	10,200	13,600	-	-
6	48	48,000	6 + 6 + 6 + 6 + 9 + 15	6,000	6,000	6,000	6,000	9,000	15,000	-	-
		54,000		6,800	6,800	6,800	6,800	10,100	16,900	-	-
6	51	48,000	6 + 6 + 6 + 6 + 9 + 18	5,600	5,600	5,600	5,600	8,500	16,900	-	-
		54,000		6,400	6,400	6,400	6,400	9,500	19,100	-	-

MXZ-8C48NA OPERATIONAL PERFORMANCE, CONTD.

NON-DUCTED:

# of Indoor Unit	Total Nominal Capacity (x1000 Btu/h)	Total Indoor Unit Capacity (Btu/h)	Operational Performance for Indoor Unit Combinations (Unit A + Unit B + Unit C + Unit D + Unit E + Unit F + Unit G + Unit H)	Cooling Capacity Range (Btu/h)							
				Heating Capacity Range (Btu/h)							
				Unit A	Unit B	Unit C	Unit D	Unit E	Unit F	Unit G	Unit H
6	57	48,000	6 + 6 + 6 + 6 + 9 + 24	5,100	5,100	5,100	5,100	7,600	20,200	-	-
		54,000		5,700	5,700	5,700	5,700	8,500	22,700	-	-
6	48	48,000	6 + 6 + 6 + 6 + 12 + 12	6,000	6,000	6,000	6,000	12,000	12,000	-	-
		54,000		6,800	6,800	6,800	6,800	13,500	13,500	-	-
6	51	48,000	6 + 6 + 6 + 6 + 12 + 15	5,600	5,600	5,600	5,600	11,300	14,100	-	-
		54,000		6,400	6,400	6,400	6,400	12,700	15,900	-	-
6	54	48,000	6 + 6 + 6 + 6 + 12 + 18	5,300	5,300	5,300	5,300	10,700	16,000	-	-
		54,000		6,000	6,000	6,000	6,000	12,000	18,000	-	-
6	60	48,000	6 + 6 + 6 + 6 + 12 + 24	4,800	4,800	4,800	4,800	9,600	19,200	-	-
		54,000		5,400	5,400	5,400	5,400	10,800	21,600	-	-
6	54	48,000	6 + 6 + 6 + 6 + 15 + 15	5,300	5,300	5,300	5,300	13,300	13,300	-	-
		54,000		6,000	6,000	6,000	6,000	15,000	15,000	-	-
6	57	48,000	6 + 6 + 6 + 6 + 15 + 18	5,100	5,100	5,100	5,100	12,600	15,200	-	-
		54,000		5,700	5,700	5,700	5,700	14,200	17,100	-	-
6	60	48,000	6 + 6 + 6 + 6 + 18 + 18	4,800	4,800	4,800	4,800	14,400	14,400	-	-
		54,000		5,400	5,400	5,400	5,400	16,200	16,200	-	-
6	45	45,000	6 + 6 + 6 + 9 + 9 + 9	6,000	6,000	6,000	9,000	9,000	9,000	-	-
		51,000		6,800	6,800	6,800	10,200	10,200	10,200	-	-
6	48	48,000	6 + 6 + 6 + 9 + 9 + 12	6,000	6,000	6,000	9,000	9,000	12,000	-	-
		54,000		6,800	6,800	6,800	10,100	10,100	13,500	-	-
6	51	48,000	6 + 6 + 6 + 9 + 9 + 15	5,600	5,600	5,600	8,500	8,500	14,100	-	-
		54,000		6,400	6,400	6,400	9,500	9,500	15,900	-	-
6	54	48,000	6 + 6 + 6 + 9 + 9 + 18	5,300	5,300	5,300	8,000	8,000	16,000	-	-
		54,000		6,000	6,000	6,000	9,000	9,000	18,000	-	-
6	60	48,000	6 + 6 + 6 + 9 + 9 + 24	4,800	4,800	4,800	7,200	7,200	19,200	-	-
		54,000		5,400	5,400	5,400	8,100	8,100	21,600	-	-
6	51	48,000	6 + 6 + 6 + 9 + 12 + 12	5,600	5,600	5,600	8,500	11,300	11,300	-	-
		54,000		6,400	6,400	6,400	9,500	12,700	12,700	-	-
6	54	48,000	6 + 6 + 6 + 9 + 12 + 15	5,300	5,300	5,300	8,000	10,700	13,300	-	-
		54,000		6,000	6,000	6,000	9,000	12,000	15,000	-	-
6	57	48,000	6 + 6 + 6 + 9 + 12 + 18	5,100	5,100	5,100	7,600	10,100	15,200	-	-
		54,000		5,700	5,700	5,700	8,500	11,400	17,100	-	-
6	57	48,000	6 + 6 + 6 + 9 + 15 + 15	5,100	5,100	5,100	7,600	12,600	12,600	-	-
		54,000		5,700	5,700	5,700	8,500	14,200	14,200	-	-
6	60	48,000	6 + 6 + 6 + 9 + 15 + 18	4,800	4,800	4,800	7,200	12,000	14,400	-	-
		54,000		5,400	5,400	5,400	8,100	13,500	16,200	-	-
6	54	48,000	6 + 6 + 6 + 12 + 12 + 12	5,300	5,300	5,300	10,700	10,700	10,700	-	-
		54,000		6,000	6,000	6,000	12,000	12,000	12,000	-	-
6	57	48,000	6 + 6 + 6 + 12 + 12 + 15	5,100	5,100	5,100	10,100	10,100	12,600	-	-
		54,000		5,700	5,700	5,700	11,400	11,400	14,200	-	-
6	60	48,000	6 + 6 + 6 + 12 + 12 + 18	4,800	4,800	4,800	9,600	9,600	14,400	-	-
		54,000		5,400	5,400	5,400	10,800	10,800	16,200	-	-
6	60	48,000	6 + 6 + 6 + 12 + 15 + 15	4,800	4,800	4,800	9,600	12,000	12,000	-	-
		54,000		5,400	5,400	5,400	10,800	13,500	13,500	-	-
6	48	48,000	6 + 6 + 9 + 9 + 9 + 9	6,000	6,000	9,000	9,000	9,000	9,000	-	-
		54,000		6,800	6,800	10,100	10,100	10,100	10,100	-	-
6	51	48,000	6 + 6 + 9 + 9 + 9 + 12	5,600	5,600	8,500	8,500	8,500	11,300	-	-
		54,000		6,400	6,400	9,500	9,500	9,500	12,700	-	-
6	54	48,000	6 + 6 + 9 + 9 + 9 + 15	5,300	5,300	8,000	8,000	8,000	13,300	-	-
		54,000		6,000	6,000	9,000	9,000	9,000	15,000	-	-
6	57	48,000	6 + 6 + 9 + 9 + 9 + 18	5,100	5,100	7,600	7,600	7,600	15,200	-	-
		54,000		5,700	5,700	8,500	8,500	8,500	17,100	-	-
6	54	48,000	6 + 6 + 9 + 9 + 12 + 12	5,300	5,300	8,000	8,000	10,700	10,700	-	-
		54,000		6,000	6,000	9,000	9,000	12,000	12,000	-	-
6	57	48,000	6 + 6 + 9 + 9 + 12 + 15	5,100	5,100	7,600	7,600	10,100	12,600	-	-
		54,000		5,700	5,700	8,500	8,500	11,400	14,200	-	-
6	60	48,000	6 + 6 + 9 + 9 + 12 + 18	4,800	4,800	7,200	7,200	9,600	14,400	-	-
		54,000		5,400	5,400	8,100	8,100	10,800	16,200	-	-
6	60	48,000	6 + 6 + 9 + 9 + 15 + 15	4,800	4,800	7,200	7,200	12,000	12,000	-	-
		54,000		5,400	5,400	8,100	8,100	13,500	13,500	-	-
6	57	48,000	6 + 6 + 9 + 12 + 12 + 12	5,100	5,100	7,600	10,100	10,100	10,100	-	-
		54,000		5,700	5,700	8,500	11,400	11,400	11,400	-	-

MXZ-8C48NA OPERATIONAL PERFORMANCE, CONTD.

NON-DUCTED:

# of Indoor Unit	Total Nominal Capacity (x1000 Btu/h)	Total Indoor Unit Capacity (Btu/h)	Operational Performance for Indoor Unit Combinations (Unit A + Unit B + Unit C + Unit D + Unit E + Unit F + Unit G + Unit H)	Cooling Capacity Range (Btu/h)							
				Heating Capacity Range (Btu/h)							
				Unit A	Unit B	Unit C	Unit D	Unit E	Unit F	Unit G	Unit H
6	60	48,000	6 + 6 + 9 + 12 + 12 + 15	4,800	4,800	7,200	9,600	9,600	12,000	-	-
		54,000		5,400	5,400	8,100	10,800	10,800	13,500	-	-
6	60	48,000	6 + 6 + 12 + 12 + 12 + 12	4,800	4,800	9,600	9,600	9,600	9,600	-	-
		54,000		5,400	5,400	10,800	10,800	10,800	10,800	-	-
6	51	48,000	6 + 9 + 9 + 9 + 9 + 9	5,600	8,500	8,500	8,500	8,500	8,500	-	-
		54,000		6,400	9,500	9,500	9,500	9,500	9,500	-	-
6	54	48,000	6 + 9 + 9 + 9 + 9 + 12	5,300	8,000	8,000	8,000	8,000	10,700	-	-
		54,000		6,000	9,000	9,000	9,000	9,000	12,000	-	-
6	57	48,000	6 + 9 + 9 + 9 + 9 + 15	5,100	7,600	7,600	7,600	7,600	12,600	-	-
		54,000		5,700	8,500	8,500	8,500	8,500	14,200	-	-
6	60	48,000	6 + 9 + 9 + 9 + 9 + 18	4,800	7,200	7,200	7,200	7,200	14,400	-	-
		54,000		5,400	8,100	8,100	8,100	8,100	16,200	-	-
6	57	48,000	6 + 9 + 9 + 9 + 12 + 12	5,100	7,600	7,600	7,600	10,100	10,100	-	-
		54,000		5,700	8,500	8,500	8,500	11,400	11,400	-	-
6	60	48,000	6 + 9 + 9 + 9 + 12 + 15	4,800	7,200	7,200	7,200	9,600	12,000	-	-
		54,000		5,400	8,100	8,100	8,100	10,800	13,500	-	-
6	60	48,000	6 + 9 + 9 + 12 + 12 + 12	4,800	7,200	7,200	9,600	9,600	9,600	-	-
		54,000		5,400	8,100	8,100	10,800	10,800	10,800	-	-
6	54	48,000	9 + 9 + 9 + 9 + 9 + 9	8,000	8,000	8,000	8,000	8,000	8,000	-	-
		54,000		9,000	9,000	9,000	9,000	9,000	9,000	-	-
6	57	48,000	9 + 9 + 9 + 9 + 9 + 12	7,600	7,600	7,600	7,600	7,600	10,100	-	-
		54,000		8,500	8,500	8,500	8,500	8,500	11,400	-	-
6	60	48,000	9 + 9 + 9 + 9 + 9 + 15	7,200	7,200	7,200	7,200	7,200	12,000	-	-
		54,000		8,100	8,100	8,100	8,100	8,100	13,500	-	-
6	60	48,000	9 + 9 + 9 + 9 + 12 + 12	7,200	7,200	7,200	7,200	9,600	9,600	-	-
		54,000		8,100	8,100	8,100	8,100	10,800	10,800	-	-
7	42	48,000	6 + 6 + 6 + 6 + 6 + 6 + 6	6,900	6,900	6,900	6,900	6,900	6,900	6,900	-
		54,000		7,700	7,700	7,700	7,700	7,700	7,700	7,700	-
7	45	48,000	6 + 6 + 6 + 6 + 6 + 6 + 9	6,400	6,400	6,400	6,400	6,400	6,400	9,600	-
		54,000		7,200	7,200	7,200	7,200	7,200	7,200	10,800	-
7	48	48,000	6 + 6 + 6 + 6 + 6 + 6 + 12	6,000	6,000	6,000	6,000	6,000	6,000	12,000	-
		54,000		6,800	6,800	6,800	6,800	6,800	6,800	13,500	-
7	51	48,000	6 + 6 + 6 + 6 + 6 + 6 + 15	5,600	5,600	5,600	5,600	5,600	5,600	14,100	-
		54,000		6,400	6,400	6,400	6,400	6,400	6,400	15,900	-
7	54	48,000	6 + 6 + 6 + 6 + 6 + 6 + 18	5,300	5,300	5,300	5,300	5,300	5,300	16,000	-
		54,000		6,000	6,000	6,000	6,000	6,000	6,000	18,000	-
7	60	48,000	6 + 6 + 6 + 6 + 6 + 6 + 24	4,800	4,800	4,800	4,800	4,800	4,800	19,200	-
		54,000		5,400	5,400	5,400	5,400	5,400	5,400	21,600	-
7	48	48,000	6 + 6 + 6 + 6 + 6 + 9 + 9	6,000	6,000	6,000	6,000	6,000	9,000	9,000	-
		54,000		6,800	6,800	6,800	6,800	6,800	10,100	10,100	-
7	51	48,000	6 + 6 + 6 + 6 + 6 + 9 + 12	5,600	5,600	5,600	5,600	5,600	8,500	11,300	-
		54,000		6,400	6,400	6,400	6,400	6,400	9,500	12,700	-
7	54	48,000	6 + 6 + 6 + 6 + 6 + 9 + 15	5,300	5,300	5,300	5,300	5,300	8,000	13,300	-
		54,000		6,000	6,000	6,000	6,000	6,000	9,000	15,000	-
7	57	48,000	6 + 6 + 6 + 6 + 6 + 9 + 18	5,100	5,100	5,100	5,100	5,100	7,600	15,200	-
		54,000		5,700	5,700	5,700	5,700	5,700	8,500	17,100	-
7	54	48,000	6 + 6 + 6 + 6 + 6 + 12 + 12	5,300	5,300	5,300	5,300	5,300	10,700	10,700	-
		54,000		6,000	6,000	6,000	6,000	6,000	12,000	12,000	-
7	57	48,000	6 + 6 + 6 + 6 + 6 + 12 + 15	5,100	5,100	5,100	5,100	5,100	10,100	12,600	-
		54,000		5,700	5,700	5,700	5,700	5,700	11,400	14,200	-
7	60	48,000	6 + 6 + 6 + 6 + 6 + 12 + 18	4,800	4,800	4,800	4,800	4,800	9,600	14,400	-
		54,000		5,400	5,400	5,400	5,400	5,400	10,800	16,200	-
7	60	48,000	6 + 6 + 6 + 6 + 6 + 15 + 15	4,800	4,800	4,800	4,800	4,800	12,000	12,000	-
		54,000		5,400	5,400	5,400	5,400	5,400	13,500	13,500	-
7	51	48,000	6 + 6 + 6 + 6 + 9 + 9 + 9	5,600	5,600	5,600	5,600	8,500	8,500	8,500	-
		54,000		6,400	6,400	6,400	6,400	9,500	9,500	9,500	-
7	54	48,000	6 + 6 + 6 + 6 + 9 + 9 + 12	5,300	5,300	5,300	5,300	8,000	8,000	10,700	-
		54,000		6,000	6,000	6,000	6,000	9,000	9,000	12,000	-
7	57	48,000	6 + 6 + 6 + 6 + 9 + 9 + 15	5,100	5,100	5,100	5,100	7,600	7,600	12,600	-
		54,000		5,700	5,700	5,700	5,700	8,500	8,500	14,200	-

Specifications are subject to change without notice.

MXZ-8C48NA OPERATIONAL PERFORMANCE, CONTD.

NON-DUCTED:

# of Indoor Unit	Total Nominal Capacity (x1000 Btu/h)	Total Indoor Unit Capacity (Btu/h)	Operational Performance for Indoor Unit Combinations (Unit A + Unit B + Unit C + Unit D + Unit E + Unit F + Unit G + Unit H)	Cooling Capacity Range (Btu/h)							
				Heating Capacity Range (Btu/h)							
				Unit A	Unit B	Unit C	Unit D	Unit E	Unit F	Unit G	Unit H
7	60	48,000	6 + 6 + 6 + 6 + 9 + 9 + 18	4,800	4,800	4,800	4,800	7,200	7,200	14,400	-
		54,000		5,400	5,400	5,400	5,400	8,100	8,100	16,200	-
7	57	48,000	6 + 6 + 6 + 6 + 9 + 12 + 12	5,100	5,100	5,100	5,100	7,600	10,100	10,100	-
		54,000		5,700	5,700	5,700	5,700	8,500	11,400	11,400	-
7	60	48,000	6 + 6 + 6 + 6 + 9 + 12 + 15	4,800	4,800	4,800	4,800	7,200	9,600	12,000	-
		54,000		5,400	5,400	5,400	5,400	8,100	10,800	13,500	-
7	60	48,000	6 + 6 + 6 + 6 + 12 + 12 + 12	4,800	4,800	4,800	4,800	9,600	9,600	9,600	-
		54,000		5,400	5,400	5,400	5,400	10,800	10,800	10,800	-
7	54	48,000	6 + 6 + 6 + 9 + 9 + 9 + 9	5,300	5,300	5,300	8,000	8,000	8,000	8,000	-
		54,000		6,000	6,000	6,000	9,000	9,000	9,000	9,000	-
7	57	48,000	6 + 6 + 6 + 9 + 9 + 9 + 12	5,100	5,100	5,100	7,600	7,600	7,600	10,100	-
		54,000		5,700	5,700	5,700	8,500	8,500	8,500	11,400	-
7	60	48,000	6 + 6 + 6 + 9 + 9 + 9 + 15	4,800	4,800	4,800	7,200	7,200	7,200	12,000	-
		54,000		5,400	5,400	5,400	8,100	8,100	8,100	13,500	-
7	60	48,000	6 + 6 + 6 + 9 + 9 + 12 + 12	4,800	4,800	4,800	7,200	7,200	9,600	9,600	-
		54,000		5,400	5,400	5,400	8,100	8,100	10,800	10,800	-
7	57	48,000	6 + 6 + 9 + 9 + 9 + 9 + 9	5,100	5,100	7,600	7,600	7,600	7,600	7,600	-
		54,000		5,700	5,700	8,500	8,500	8,500	8,500	8,500	-
7	60	48,000	6 + 6 + 9 + 9 + 9 + 9 + 12	4,800	4,800	7,200	7,200	7,200	7,200	9,600	-
		54,000		5,400	5,400	8,100	8,100	8,100	8,100	10,800	-
7	60	48,000	6 + 9 + 9 + 9 + 9 + 9 + 9	4,800	7,200	7,200	7,200	7,200	7,200	7,200	-
		54,000		5,400	8,100	8,100	8,100	8,100	8,100	8,100	-
8	48	48,000	6 + 6 + 6 + 6 + 6 + 6 + 6 + 6	6,000	6,000	6,000	6,000	6,000	6,000	6,000	6,000
		54,000		6,800	6,800	6,800	6,800	6,800	6,800	6,800	6,800
8	51	48,000	6 + 6 + 6 + 6 + 6 + 6 + 6 + 9	5,600	5,600	5,600	5,600	5,600	5,600	5,600	8,500
		54,000		6,400	6,400	6,400	6,400	6,400	6,400	6,400	9,500
8	54	48,000	6 + 6 + 6 + 6 + 6 + 6 + 6 + 12	5,300	5,300	5,300	5,300	5,300	5,300	5,300	10,700
		54,000		6,000	6,000	6,000	6,000	6,000	6,000	6,000	12,000
8	57	48,000	6 + 6 + 6 + 6 + 6 + 6 + 6 + 15	5,100	5,100	5,100	5,100	5,100	5,100	5,100	12,600
		54,000		5,700	5,700	5,700	5,700	5,700	5,700	5,700	14,200
8	60	48,000	6 + 6 + 6 + 6 + 6 + 6 + 6 + 18	4,800	4,800	4,800	4,800	4,800	4,800	4,800	14,400
		54,000		5,400	5,400	5,400	5,400	5,400	5,400	5,400	16,200
8	54	48,000	6 + 6 + 6 + 6 + 6 + 6 + 9 + 9	5,300	5,300	5,300	5,300	5,300	5,300	8,000	8,000
		54,000		6,000	6,000	6,000	6,000	6,000	6,000	9,000	9,000
8	57	48,000	6 + 6 + 6 + 6 + 6 + 6 + 9 + 12	5,100	5,100	5,100	5,100	5,100	5,100	7,600	10,100
		54,000		5,700	5,700	5,700	5,700	5,700	5,700	8,500	11,400
8	60	48,000	6 + 6 + 6 + 6 + 6 + 6 + 9 + 15	4,800	4,800	4,800	4,800	4,800	4,800	7,200	12,000
		54,000		5,400	5,400	5,400	5,400	5,400	5,400	8,100	13,500
8	60	48,000	6 + 6 + 6 + 6 + 6 + 6 + 12 + 12	4,800	4,800	4,800	4,800	4,800	4,800	9,600	9,600
		54,000		5,400	5,400	5,400	5,400	5,400	5,400	10,800	10,800
8	57	48,000	6 + 6 + 6 + 6 + 6 + 9 + 9 + 9	5,100	5,100	5,100	5,100	5,100	7,600	7,600	7,600
		54,000		5,700	5,700	5,700	5,700	5,700	8,500	8,500	8,500
8	60	48,000	6 + 6 + 6 + 6 + 6 + 9 + 9 + 12	4,800	4,800	4,800	4,800	4,800	7,200	7,200	9,600
		54,000		5,400	5,400	5,400	5,400	5,400	8,100	8,100	10,800
8	60	48,000	6 + 6 + 6 + 6 + 9 + 9 + 9 + 9	4,800	4,800	4,800	4,800	7,200	7,200	7,200	7,200
		54,000		5,400	5,400	5,400	5,400	8,100	8,100	8,100	8,100

DIMENSIONS: PAC-MKA30, 31BC AND PAC-MKA50, 51BC BRANCH BOXES

Unit: mm <in>

PAC-MKA30BC & PAC-MKA31BC

SUSPENSION BOLT : W3/8(M10)

REFRIGERANT PIPE FLARED CONNECTION

	A	B	C		TO OUTDOOR UNIT
LIQUID PIPE	1/4F	1/4F	1/4F		3/8F
GAS PIPE	3/8F	3/8F	3/8F		5/8F

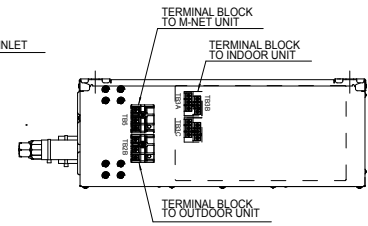
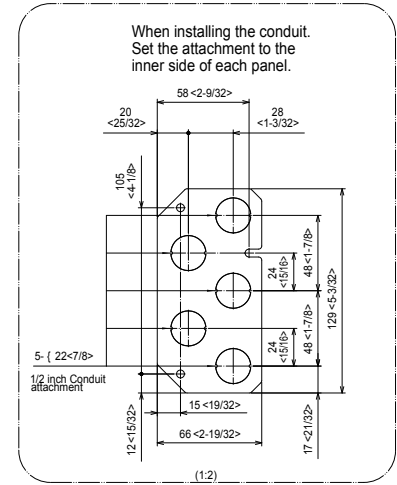
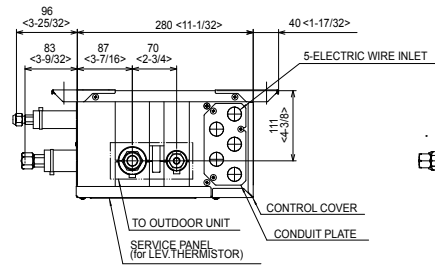
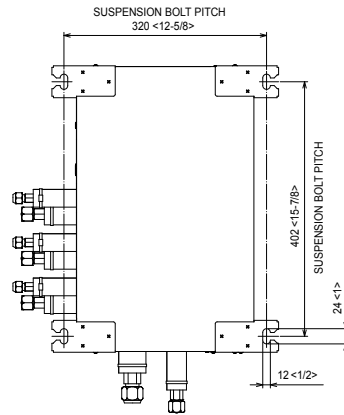
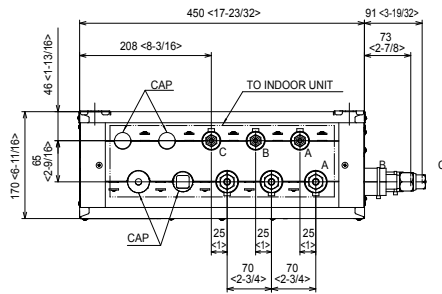

Unit: mm <in>

PAC-MKA50BC & PAC-MKA51BC

SUSPENSION BOLT : W3/8(M10)

REFRIGERANT PIPE FLARED CONNECTION

	A	B	C	D	E	To Outdoor Unit
LIQUID PIPE	1/4F	1/4F	1/4F	1/4F	1/4F	3/8F
GAS PIPE	3/8F	3/8F	3/8F	3/8F	1/2F	5/8F

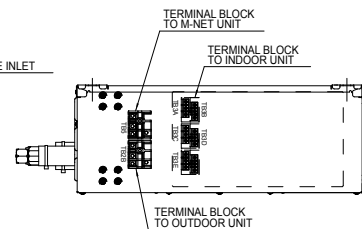
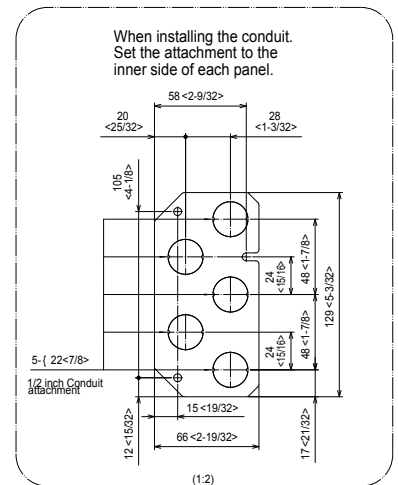
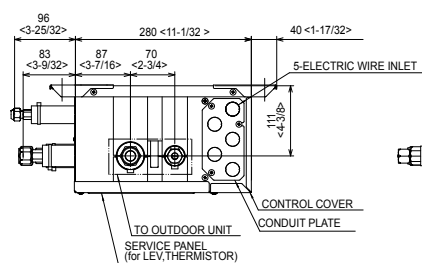
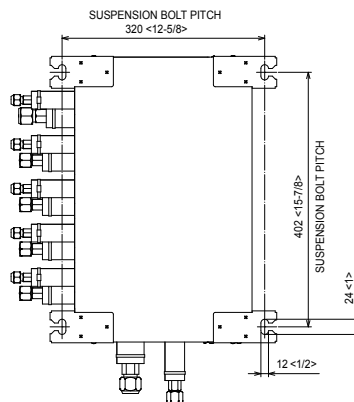
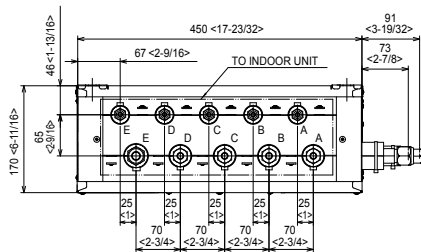

DIMENSIONS: MXZ-8C48NA

Unit: mm <in>

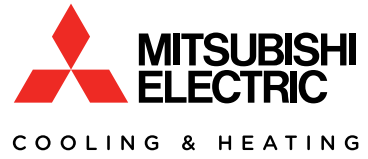
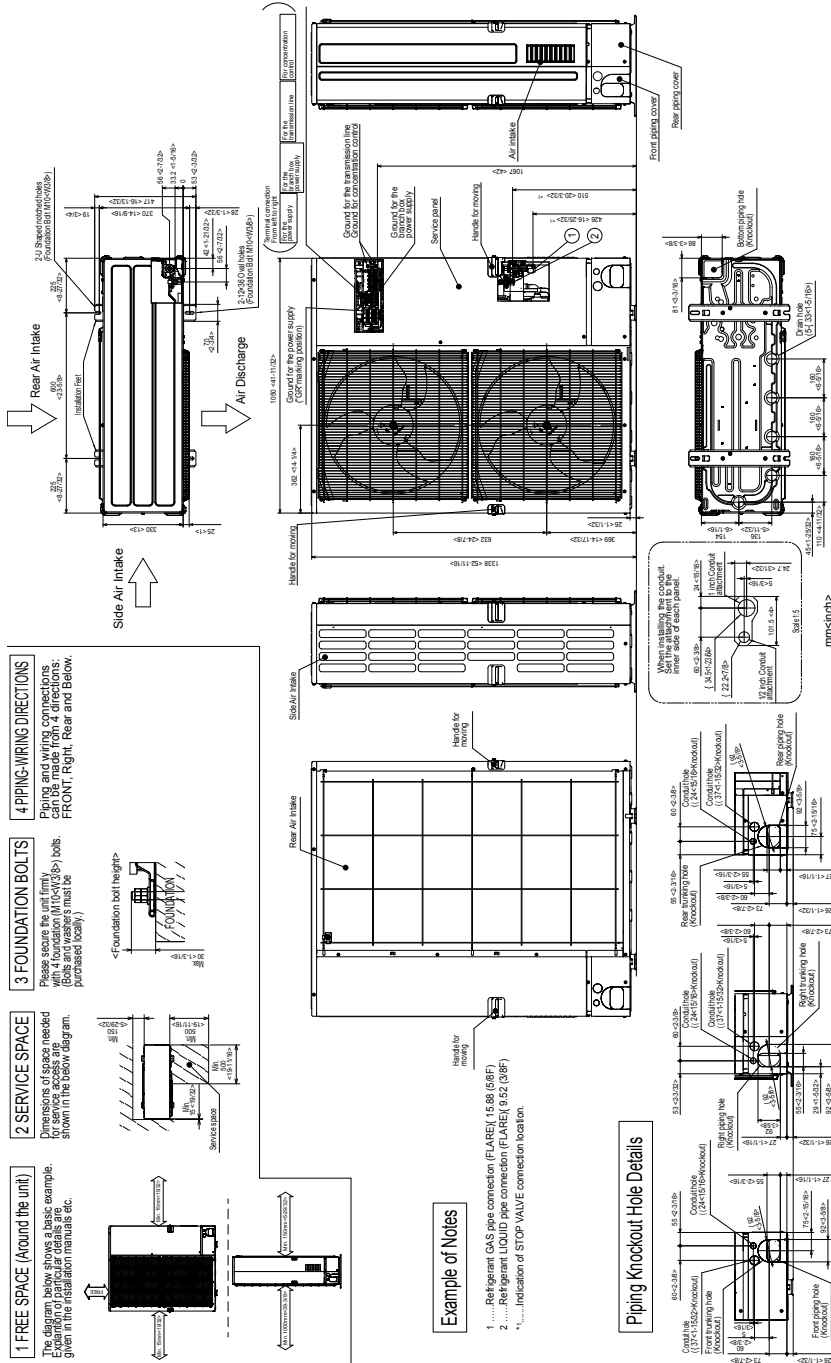

1340 Satellite Boulevard, Suwanee, GA 30024
Toll Free: 800-433-4822 www.mehvac.com

