

Revision G:

- Inverter P.C. board, service panel, terminal block and condenser net for MUZ-GE24NA have been changed.

Please void OBB549 REVISED EDITION-F.

OUTDOOR UNIT

**No. OBB549
REVISED EDITION-G**

PARTS CATALOG

Models

MUZ-GE09NA
 MUZ-GE09NA2
 MUZ-GE12NA
 MUZ-GE12NA2
 MUZ-GE15NA, - 1
 MUZ-GE15NA2
 MUZ-GE18NA, - 1
 MUZ-GE24NA
 MUY-GE09NA
 MUY-GE09NA2
 MUY-GE12NA
 MUY-GE12NA2
 MUY-GE15NA, - 1
 MUY-GE15NA2

MUZ-GE09NAH
 MUZ-GE09NAH2
 MUZ-GE12NAH
 MUZ-GE12NAH2
 MUZ-GE15NAH
 MUZ-GE15NAH2
 MUZ-GE18NAH

MUY-GE18NA, - 1
 MUY-GE24NA

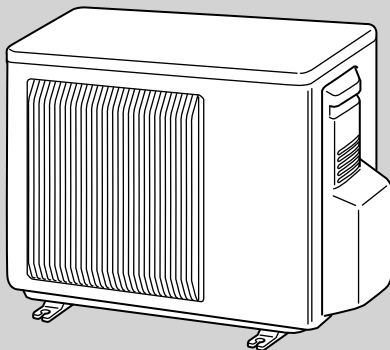

MUZ-GE09NA/NA2 MUZ-GE09NAH/NAH2
 MUZ-GE12NA/NA2 MUZ-GE12NAH/NAH2
 MUZ-GE15NA, - 1/NA2 MUZ-GE15NAH/NAH2
 MUY-GE09NA/NA2
 MUY-GE12NA/NA2
 MUY-GE15NA, - 1/NA2

CONTENTS

1. RoHS PARTS LIST..... 2
2. OPTIONAL PARTS.....14

SERVICE MANUAL (OBH549)

NOTE:
 RoHS compliant products have <G> mark on the spec name plate.

Revision A:

- MUZ-GE24NA and MUY-GE24NA have been added.
- The fan guard for MUZ-GE18NA has been changed.

Revision B:

- Descriptions regarding the outdoor fan motor has been corrected.

Revision C:

- MUZ-GE15NA-□, MUZ-GE18NA-□, MUY-GE15NA-□, and MUY-GE18NA-□ have been added.

Revision D:

- Incorrect model name and illustration have been corrected.

Revision E:

- MSZ-GE09NAH, MSZ-GE12NAH, MSZ-GE15NAH and MSZ-GE18NAH have been added.

Revision F:

- MUZ-GE09/12/15NA2, MUZ-GE09/12/15NAH2 and MUY-GE09/12/15NA2 have been added.

Revision G:

- Inverter P.C. board, service panel, terminal block and condenser net for MUZ-GE24NA have been changed.

1

RoHS PARTS LIST

MUZ-GE09NA MUZ-GE12NA MUZ-GE15NA
MUZ-GE09NAH MUZ-GE12NAH MUZ-GE15NAH
MUY-GE09NA MUY-GE12NA MUY-GE15NA

1-1. OUTDOOR UNIT STRUCTURAL PARTS AND FUNCTIONAL PARTS

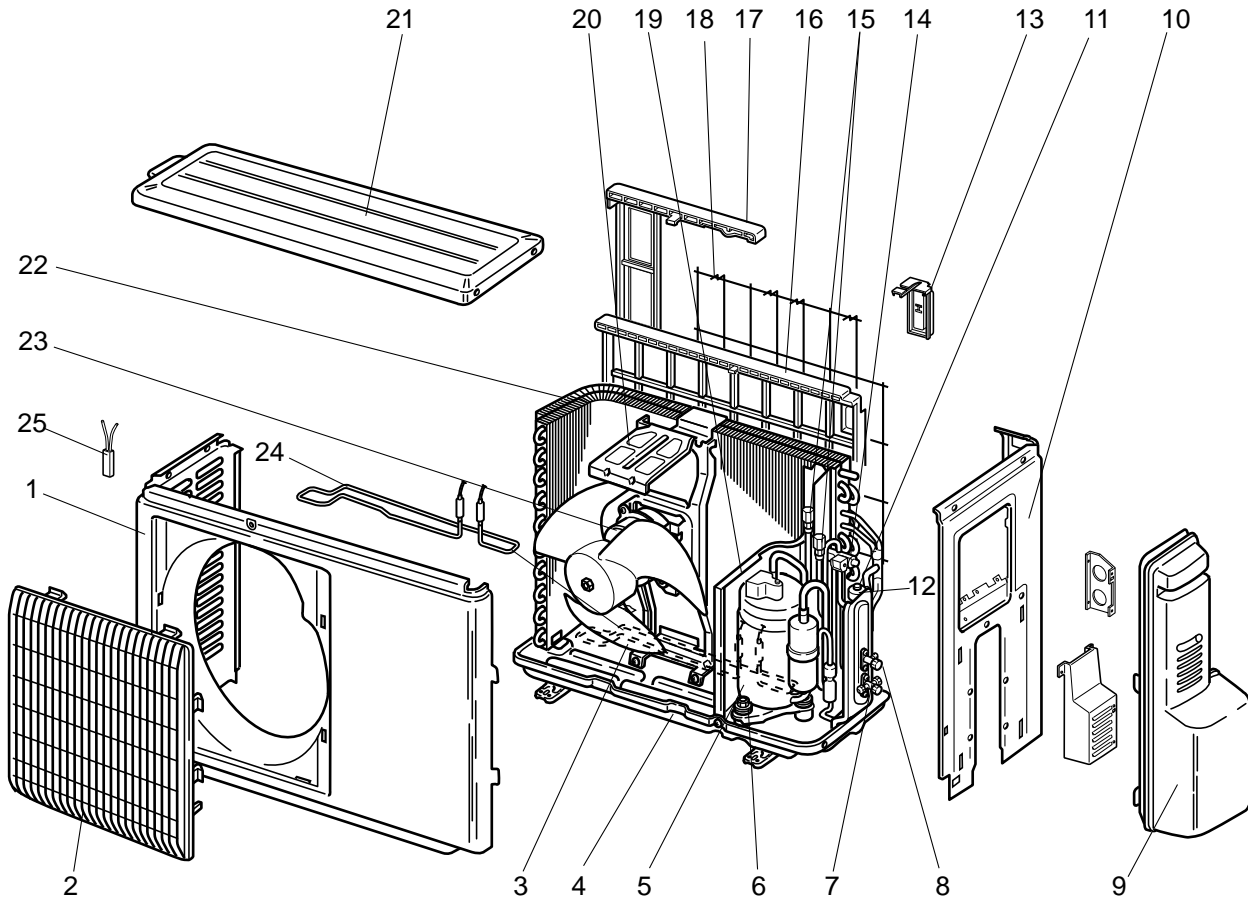

RoHS PARTS LIST

1-1. OUTDOOR UNIT STRUCTURAL PARTS AND FUNCTIONAL PARTS

Part numbers that are circled are not shown in the illustration.

No.	RoHS	Part No.	Part name	Symbol in Wiring Diagram	Q'ty/unit										Remarks	
					MUZ-GE					MUY-GE						
					09 NA	09 NAH	12 NA	12 NAH	15 NA	15NA -1	15 NAH	09 NA	12 NA	15 NA		15NA -1
1	G	E12 927 232	CABINET		1	1	1	1	1	1	1	1	1	1	1	
2	G	E12 927 521	GRILLE		1	1	1	1	1	1	1	1	1	1	1	
3	G	E12 927 501	PROPELLER		1	1	1	1	1	1	1	1	1	1	1	
4	G	E12 A82 290	BASE		1		1		1	1		1	1	1	1	
	G	E12 G68 290	BASE			1		1			1					
5	G	E12 E79 900	COMPRESSOR	MC	1	1						1				KNB073FQDHC
	G	E12 E80 900	COMPRESSOR	MC			1	1					1			KNB092FQAHC
	G	E12 E34 900	COMPRESSOR	MC					1					1		SNB130FQBH
	G	E12 G73 900	COMPRESSOR	MC						1	1				1	SNB130FQBHT
6	G	E12 C34 506	COMPRESSOR RUBBER SET						3	3	3			3	3	3RUBBERS/SET
	G	E12 065 506	COMPRESSOR RUBBER SET		3	3	3	3					3	3		3RUBBERS/SET
7	G	E12 A54 661	STOP VALVE (GAS) (ø9.52)		1	1	1	1					1	1		ø3/8
	G	E12 A56 661	STOP VALVE (GAS) (ø12.7)						1	1	1			1	1	ø1/2
8	G	E12 927 662	STOP VALVE (LIQUID) (ø6.35)		1	1	1	1	1	1	1	1	1	1	1	ø1/4
9	G	E12 A49 245	SERVICE PANEL		1	1	1	1	1	1	1	1	1	1	1	
10	G	E12 E79 233	BACK PANEL		1	1	1	1	1	1	1	1	1	1	1	
11	G	E12 A54 640	EXPANSION VALVE						1	1	1			1	1	
	G	E12 927 640	EXPANSION VALVE		1	1	1	1					1	1		
12	G	E12 927 493	EXPANSION VALVE COIL	LEV	1	1	1	1	1	1	1	1	1	1	1	
13	G	E12 928 079	THERMO HOLDER		1	1										
	G	E12 930 079	THERMO HOLDER				1	1	1	1	1					
14	G	E12 A54 961	4-WAY VALVE		1	1	1	1	1	1	1	1	1	1	1	
15	G	E12 E79 641	SERVICE PORT		2	2	2	2	2	2	2	2	2	2	2	1PC/SET
16	G	E12 838 523	CONDENSER NET										1			
	G	E12 929 523	CONDENSER NET											1	1	1
17	G	E12 928 523	CONDENSER NET		1	1										
	G	E12 930 523	CONDENSER NET				1	1	1	1	1					
18	G	E12 928 525	CONDENSER WIRE NET		1	1										
	G	E12 930 525	CONDENSER WIRE NET				1	1	1	1	1					
19	G	E12 D69 293	SEPARATOR		1								1			
	G	E12 D77 293	SEPARATOR			1										
	G	E12 C34 293	SEPARATOR				1		1	1				1	1	1
	G	E12 C36 293	SEPARATOR					1			1					
20	G	E12 929 515	MOTOR SUPPORT				1	1	1	1	1			1	1	1
	G	E12 927 515	MOTOR SUPPORT		1	1							1			
21	G	E12 927 297	TOP PANEL		1	1	1	1	1	1	1	1	1	1	1	
22	G	E12 N09 630	OUTDOOR HEAT EXCHANGER		1	1										
	G	E12 N10 630	OUTDOOR HEAT EXCHANGER				1	1	1	1	1					
	G	E12 N15 630	OUTDOOR HEAT EXCHANGER										1			
	G	E12 N16 630	OUTDOOR HEAT EXCHANGER											1	1	1
23	G	E12 E79 301	OUTDOOR FAN MOTOR	MF	1	1	1	1	1	1	1	1	1	1	1	RC0J55-□ □
24	G	E12 C36 526	DEFROST HEATER	H		1		1			1					
25	G	E12 C36 381	HEATER PROTECTOR	26H		1		1			1					
②⑥	G	E12 927 937	CAPILLARY TUBE (ø3.0×ø2.0×240)		1	1	1	1	1	1	1	1	1	1	1	O.D. 0.118 × I.D. 0.079 × 9-7/16
②⑦	G	E12 735 936	CAPILLARY TUBE (ø3.0×ø1.8×600)				2	2	2	2	2			2	2	O.D. 0.118 × I.D. 0.071 × 23-5/8

RoHS PARTS LIST

MUZ-GE09NA MUZ-GE12NA MUZ-GE15NA
MUZ-GE09NAH MUZ-GE12NAH MUZ-GE15NAH
MUY-GE09NA MUY-GE12NA MUY-GE15NA
1-2. OUTDOOR UNIT ELECTRICAL PARTS

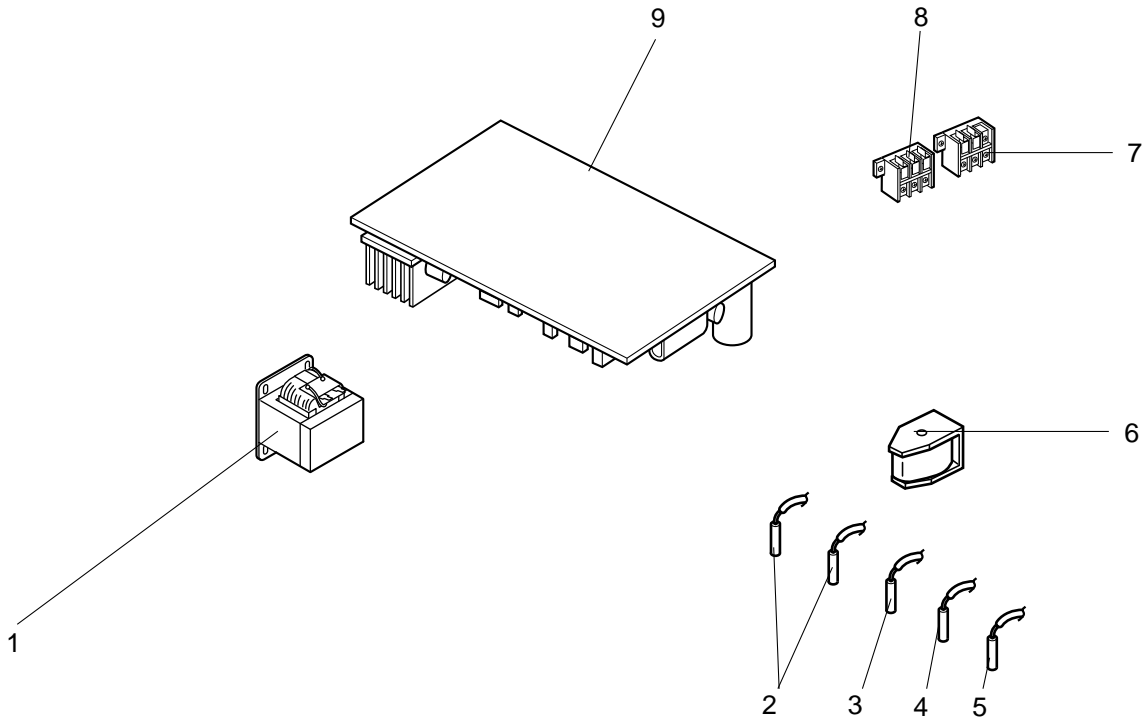

RoHS PARTS LIST

1-2. OUTDOOR UNIT ELECTRICAL PARTS

No.	RoHS	Part No.	Part name	Symbol in Wiring Diagram	Q'ty/unit										Remarks	
					MUZ-GE					MUY-GE						
					09 NA	09 NAH	12 NA	12 NAH	15 NA	15NA -[1]	15 NAH	09 NA	12 NA	15 NA		15NA -[1]
1	G	E12 G10 337	REACTOR	L61	1	1						1				
	G	E12 838 337	REACTOR	L61			1	1	1	1	1		1	1	1	
2	G	E12 C34 306	THERMISTOR SET	RT61, RT62	1	1	1	1	1	1	1					DEFROST, DISCHARGE
3	G	E12 E99 306	DISCHARGE TEMP. THERMISTOR	RT62								1	1	1	1	
4	G	E12 927 308	AMBIENT TEMPERATURE THERMISTOR	RT65	1	1	1	1	1	1	1	1	1	1	1	
5	G	E12 C34 307	OUTDOOR HEAT EXCHANGER TEMPERATURE THERMISTOR	RT68	1	1	1	1	1	1	1	1	1	1	1	
6	G	E12 C85 490	R.V. COIL	21S4	1	1	1	1	1	1	1					
7	G	E12 A53 374	TERMINAL BLOCK	TB1	1	1	1	1	1	1	1	1	1	1	1	2P
8	G	E12 927 374	TERMINAL BLOCK	TB2	1	1	1	1	1	1	1	1	1	1	1	3P
9	G	E12 E79 451	INVERTER P.C. BOARD		1											Including heat sink and RT64
	G	E12 H94 451	INVERTER P.C. BOARD			1										
	G	E12 E80 451	INVERTER P.C. BOARD				1									
	G	E12 H95 451	INVERTER P.C. BOARD					1								
	G	E12 E81 451	INVERTER P.C. BOARD						1							
	G	E12 G73 451	INVERTER P.C. BOARD							1						
	G	E12 H96 451	INVERTER P.C. BOARD								1					
	G	E12 E83 451	INVERTER P.C. BOARD									1				
	G	E12 E84 451	INVERTER P.C. BOARD										1			
	G	E12 E85 451	INVERTER P.C. BOARD											1		
	G	E12 G75 451	INVERTER P.C. BOARD												1	

RoHS PARTS LIST

MUZ-GE09NA2 MUZ-GE12NA2 MUZ-GE15NA2
MUZ-GE09NAH2 MUZ-GE12NAH2 MUZ-GE15NAH2
MUY-GE09NA2 MUY-GE12NA2 MUY-GE15NA2

1-3. OUTDOOR UNIT STRUCTURAL PARTS AND FUNCTIONAL PARTS

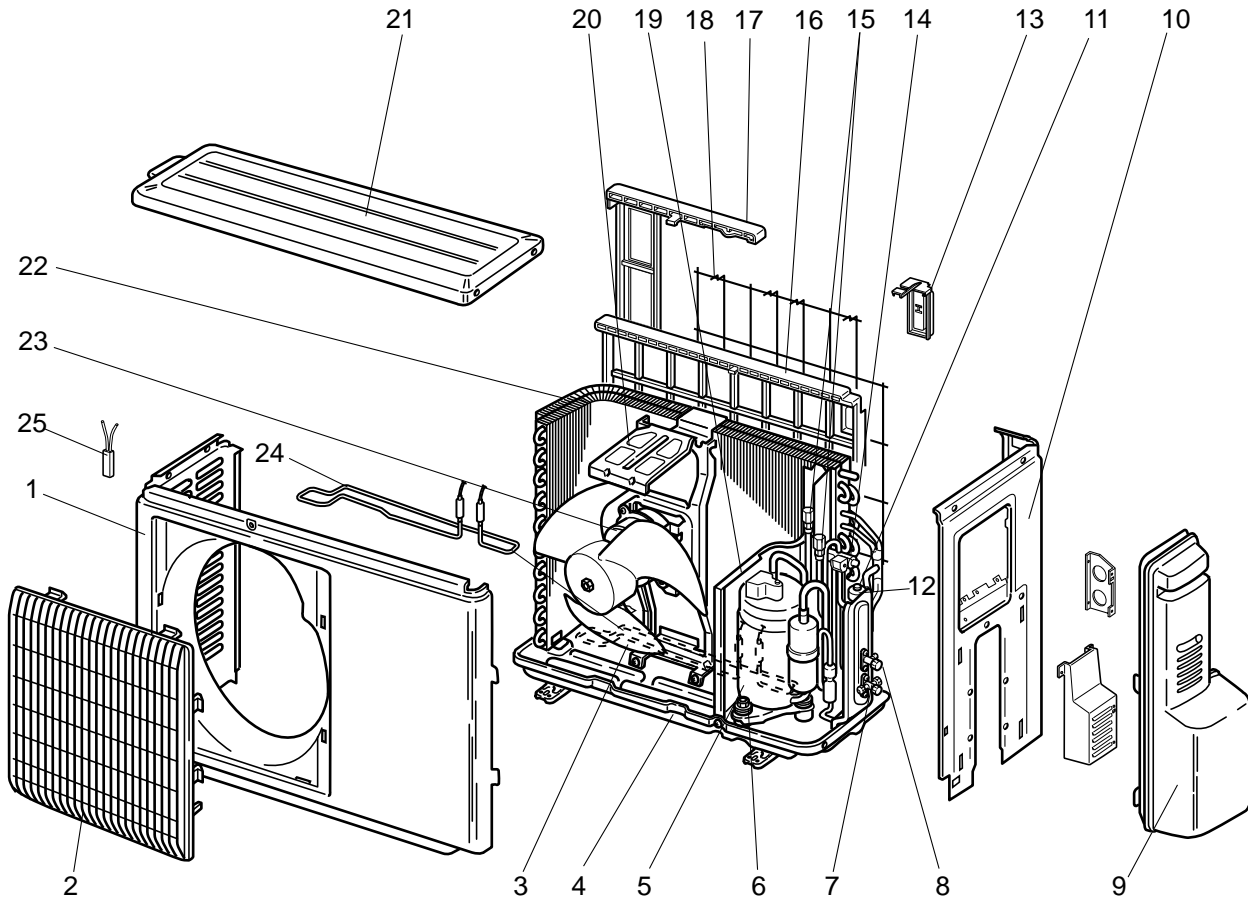

RoHS PARTS LIST

1-3. OUTDOOR UNIT STRUCTURAL PARTS AND FUNCTIONAL PARTS

Part numbers that are circled are not shown in the illustration.

No.	RoHS	Part No.	Part name	Symbol in Wiring Diagram	Q'ty/unit									Remarks	
					MUZ-GE						MUY-GE				
					09 NA2	09 NAH2	12 NA2	12 NAH2	15 NA2	15 NAH2	09 NA2	12 NA2	15 NA2		
1	G	E12 927 232	CABINET		1	1	1	1	1	1	1	1	1	1	
2	G	E12 927 521	GRILLE		1	1	1	1	1	1	1	1	1	1	
3	G	E12 927 501	PROPELLER		1	1	1	1	1	1	1	1	1	1	
4	G	E12 A82 290	BASE		1		1		1		1	1	1		
	G	E12 G68 290	BASE			1		1		1					
5	G	E12 E79 900	COMPRESSOR	MC	1	1					1				KNB073FQDHC
	G	E12 E80 900	COMPRESSOR	MC			1	1				1			KNB092FQAHC
	G	E12 G73 900	COMPRESSOR	MC					1	1			1		SNB130FQBHT
6	G	E12 C34 506	COMPRESSOR RUBBER SET					3	3				3		3RUBBERS/SET
	G	E12 065 506	COMPRESSOR RUBBER SET		3	3	3	3			3	3			3RUBBERS/SET
7	G	E12 A54 661	STOP VALVE (GAS) (ø9.52)		1	1	1	1			1	1			ø3/8
	G	E12 A56 661	STOP VALVE (GAS) (ø12.7)						1	1				1	ø1/2
8	G	E12 927 662	STOP VALVE (LIQUID) (ø6.35)		1	1	1	1	1	1	1	1	1	1	ø1/4
9	G	E12 A49 245	SERVICE PANEL		1	1	1	1	1	1	1	1	1	1	
10	G	E12 E79 233	BACK PANEL		1	1	1	1	1	1	1	1	1	1	
11	G	E12 A54 640	EXPANSION VALVE						1	1				1	
	G	E12 927 640	EXPANSION VALVE		1	1	1	1			1	1			
12	G	E12 927 493	EXPANSION VALVE COIL	LEV	1	1	1	1	1	1	1	1	1	1	
13	G	E12 928 079	THERMO HOLDER		1	1									
	G	E12 930 079	THERMO HOLDER				1	1	1	1					
14	G	E12 A54 961	4-WAY VALVE		1	1	1	1	1	1	1	1	1	1	
15	G	E12 E79 641	SERVICE PORT		2	2	2	2	2	2	2	2	2	2	1PC/SET
16	G	E12 838 523	CONDENSER NET								1				
	G	E12 929 523	CONDENSER NET									1	1		
17	G	E12 928 523	CONDENSER NET		1	1									
	G	E12 930 523	CONDENSER NET				1	1	1	1					
18	G	E12 928 525	CONDENSER WIRE NET		1	1									
	G	E12 930 525	CONDENSER WIRE NET				1	1	1	1					
19	G	E12 D69 293	SEPARATOR		1						1				
	G	E12 D77 293	SEPARATOR			1									
	G	E12 C34 293	SEPARATOR				1		1			1	1		
	G	E12 C36 293	SEPARATOR					1		1					
20	G	E12 929 515	MOTOR SUPPORT				1	1	1	1		1	1		
	G	E12 927 515	MOTOR SUPPORT		1	1					1				
21	G	E12 927 297	TOP PANEL		1	1	1	1	1	1	1	1	1	1	
22	G	E12 N09 630	OUTDOOR HEAT EXCHANGER		1	1									
	G	E12 N10 630	OUTDOOR HEAT EXCHANGER				1	1	1	1					
	G	E12 N15 630	OUTDOOR HEAT EXCHANGER								1				
	G	E12 N16 630	OUTDOOR HEAT EXCHANGER									1	1		
23	G	E12 E79 301	OUTDOOR FAN MOTOR	MF	1	1	1	1	1	1	1	1	1	1	RC0J55-□ □
24	G	E12 C36 526	DEFROST HEATER	H		1		1		1					
25	G	E12 C36 381	HEATER PROTECTOR	26H		1		1		1					
Ⓔ	G	E12 927 937	CAPILLARY TUBE (ø3.0×ø2.0×240)		1	1	1	1	1	1	1	1	1	1	O.D. 0.118 × I.D. 0.079 × 9-7/16
Ⓕ	G	E12 735 936	CAPILLARY TUBE (ø3.0×ø1.8×600)				2	2	2	2		2	2		O.D. 0.118 × I.D. 0.071 × 23-5/8

RoHS PARTS LIST

MUZ-GE09NA2 MUZ-GE12NA2 MUZ-GE15NA2
MUZ-GE09NAH2 MUZ-GE12NAH2 MUZ-GE15NAH2
MUY-GE09NA2 MUY-GE12NA2 MUY-GE15NA2

1-4. OUTDOOR UNIT ELECTRICAL PARTS

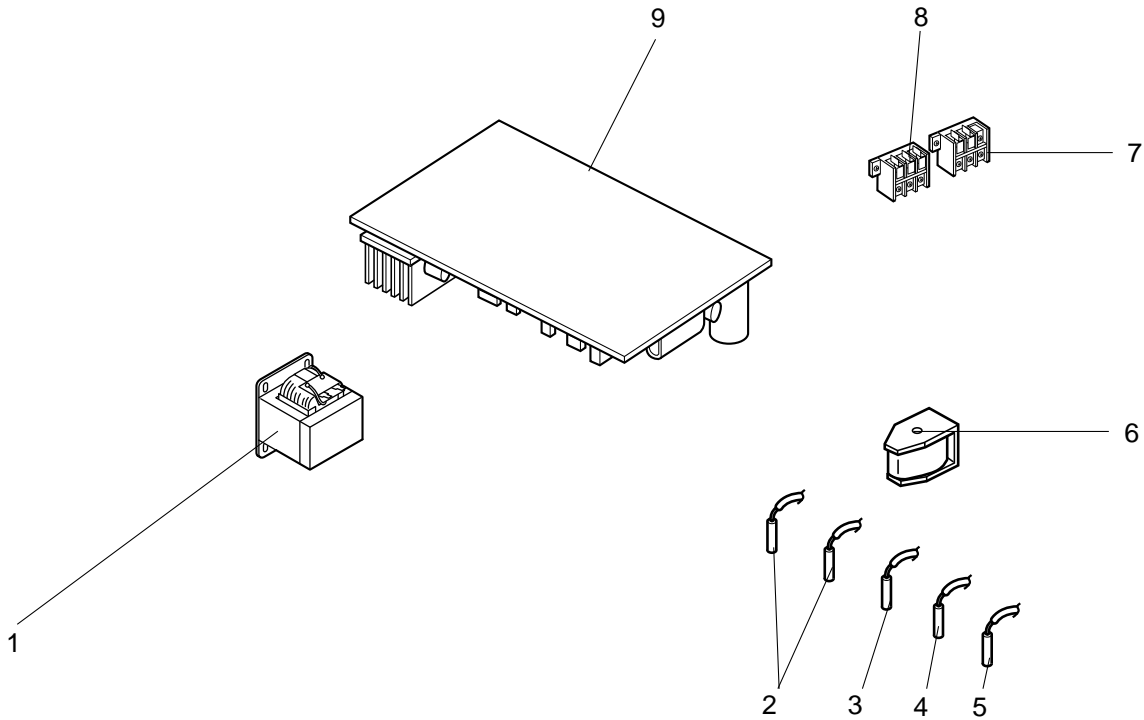

RoHS PARTS LIST

1-4. OUTDOOR UNIT ELECTRICAL PARTS

No.	RoHS	Part No.	Part name	Symbol in Wiring Diagram	Q'ty/unit									Remarks
					MUZ-GE						MUY-GE			
					09 NA2	09 NAH2	12 NA2	12 NAH2	15 NA2	15 NAH2	09 NA2	12 NA2	15 NA2	
1	G	E12 G10 337	REACTOR	L61	1	1					1			
	G	E12 838 337	REACTOR	L61			1	1	1	1		1	1	
2	G	E12 C34 306	THERMISTOR SET	RT61, RT62	1	1	1	1	1	1				DEFROST, DISCHARGE
3	G	E12 E99 306	DISCHARGE TEMP. THERMISTOR	RT62							1	1	1	
4	G	E12 927 308	AMBIENT TEMPERATURE THERMISTOR	RT65	1	1	1	1	1	1	1	1	1	
5	G	E12 C34 307	OUTDOOR HEAT EXCHANGER TEMPERATURE THERMISTOR	RT68	1	1	1	1	1	1	1	1	1	
6	G	E12 C85 490	R.V. COIL	21S4	1	1	1	1	1	1				
7	G	E12 A53 374	TERMINAL BLOCK	TB1	1	1	1	1	1	1	1	1	1	2P
8	G	E12 927 374	TERMINAL BLOCK	TB2	1	1	1	1	1	1	1	1	1	3P
9	G	E12 E79 451	INVERTER P.C. BOARD		1									Including heat sink and RT64
	G	E12 H94 451	INVERTER P.C. BOARD			1								
	G	E12 E80 451	INVERTER P.C. BOARD				1							
	G	E12 H95 451	INVERTER P.C. BOARD					1						
	G	E12 G73 451	INVERTER P.C. BOARD						1					
	G	E12 H96 451	INVERTER P.C. BOARD							1				
	G	E12 E83 451	INVERTER P.C. BOARD								1			
	G	E12 E84 451	INVERTER P.C. BOARD									1		
	G	E12 G75 451	INVERTER P.C. BOARD										1	

RoHS PARTS LIST

MUZ-GE18NA
MUZ-GF18NAH
MUY-GE18NA

1-5. OUTDOOR UNIT STRUCTURAL PARTS, ELECTRICAL PARTS AND FUNCTIONAL PARTS

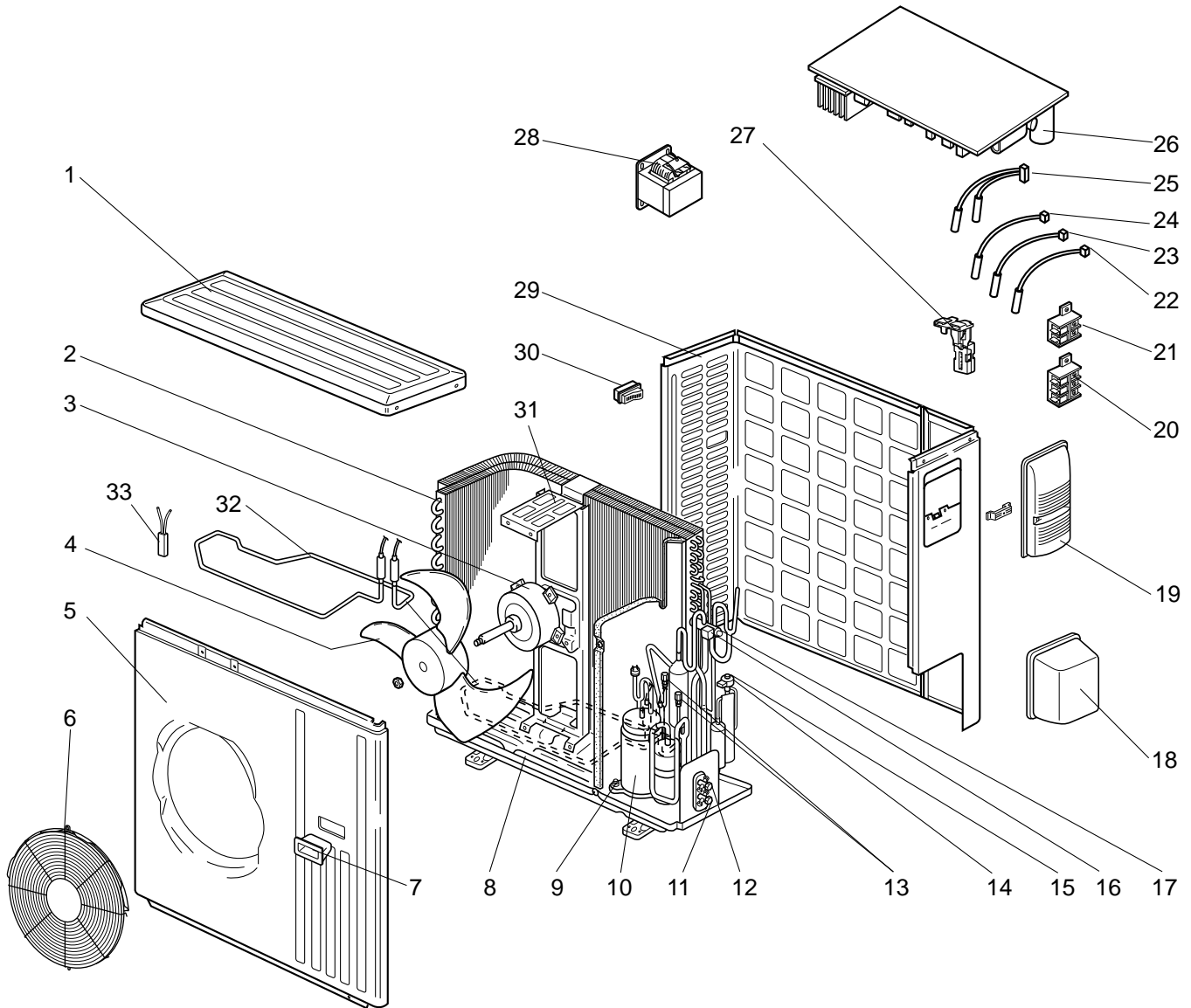

RoHS PARTS LIST

1-5. OUTDOOR UNIT STRUCTURAL PARTS, ELECTRICAL PARTS AND FUNCTIONAL PARTS

Part numbers that is circled is not shown in the illustration.

No.	RoHS	Part No.	Part Name	Symbol in Wiring Diagram	Q'ty/unit					Remarks
					MUZ-GE			MUY-GE		
					18 NA	18 NA- ①	18 NAH	18 NA	18 NA- ①	
1	G	E12 819 297	TOP PANEL		1	1	1	1	1	
2	G	E12 E82 630	OUTDOOR HEAT EXCHANGER		1	1	1			
	G	E12 E86 630	OUTDOOR HEAT EXCHANGER					1	1	
3	G	E12 E34 301	OUTDOOR FAN MOTOR	MF	1	1	1	1	1	RC0J77-□□
4	G	E12 851 501	PROPELLER		1	1	1	1	1	
5	G	E12 819 232	CABINET		1	1	1	1	1	
6	G	E12 D84 521	FAN GUARD		1	1	1			Including ice guard
	G	E12 819 521	FAN GUARD					1	1	
7	G	E12 819 009	HANDLE		1	1	1	1	1	
8	G	E12 D86 290	BASE		1	1		1	1	
	G	E12 D84 290	BASE				1			
9	G	E12 C34 506	COMPRESSOR RUBBER SET		3	3	3	3	3	3RUBBERS/SET
10	G	E12 E34 900	COMPRESSOR	MC	1			1		SNB130FQBH
	G	E12 G73 900	COMPRESSOR	MC		1	1		1	SNB130FQBHT
11	G	E12 A56 661	STOP VALVE (GAS) (ø12.7)		1	1	1	1	1	ø1/2
12	G	E12 927 662	STOP VALVE (LIQUID) (ø6.35)		1	1	1	1	1	ø1/4
13	G	E12 E79 641	SERVICE PORT		2	2	2	2	2	1 PC/SET
14	G	E12 E05 493	EXPANSION VALVE COIL	LEV	1	1	1	1	1	
15	G	E12 851 640	EXPANSION VALVE		1	1	1	1	1	
16	G	E12 E82 490	R.V. COIL	21S4	1	1	1			
17	G	E12 A56 961	4-WAY VALVE		1	1	1	1	1	
18	G	E12 819 650	VALVE COVER		1	1	1	1	1	
19	G	E12 E82 245	SERVICE PANEL		1	1	1	1	1	
20	G	E12 935 374	TERMINAL BLOCK	TB2	1	1	1	1	1	3 P
21	G	E12 A54 374	TERMINAL BLOCK	TB1	1	1	1	1	1	2 P
22	G	E12 E05 307	OUTDOOR HEAT EXCHANGER TEMP. THERMISTOR	RT68	1	1	1	1	1	
23	G	E12 D58 309	AMBIENT TEMPERATURE THERMISTOR	RT65	1	1	1	1	1	
24	G	E12 F05 308	DISCHARGE TEMPERATURE THERMISTOR	RT62				1	1	
25	G	E12 E05 308	THERMISTOR SET	RT61,RT62	1	1	1			DEFROST, DISCHARGE
26	G	E12 E82 451	INVERTER P.C. BOARD		1					Including heat sink and RT64
	G	E12 G74 451	INVERTER P.C. BOARD			1				Including heat sink and RT64
	G	E12 G72 451	INVERTER P.C. BOARD				1			Including heat sink and RT64
	G	E12 E86 451	INVERTER P.C. BOARD					1		Including heat sink and RT64
	G	E12 G76 451	INVERTER P.C. BOARD						1	Including heat sink and RT64
27	G	E12 E82 079	THERMO HOLDER		1	1	1	1	1	
28	G	E12 D58 337	REACTOR	L61	1	1	1	1	1	
29	G	E12 E82 233	BACK PANEL (OUT)		1	1	1			
	G	E12 E86 233	BACK PANEL (OUT)					1	1	
30	G	E12 817 009	HANDLE		1	1	1	1	1	
31	G	E12 851 515	MOTOR SUPPORT		1	1	1	1	1	
32	G	E12 E05 526	DEFROST HEATER	H			1			
33	G	E12 E05 381	HEATER PROTECTOR	26H			1			
③④	G	E12 853 936	CAPILLARY TUBE (ø3.6×ø2.4×50)		1	1	1	1	1	O.D. 0.142 × I.D. 0.094 × 1-31/32

RoHS PARTS LIST

MUZ-GE24NA
MUY-GE24NA

1-6. OUTDOOR UNIT STRUCTURAL PARTS, ELECTRICAL PARTS AND FUNCTIONAL PARTS

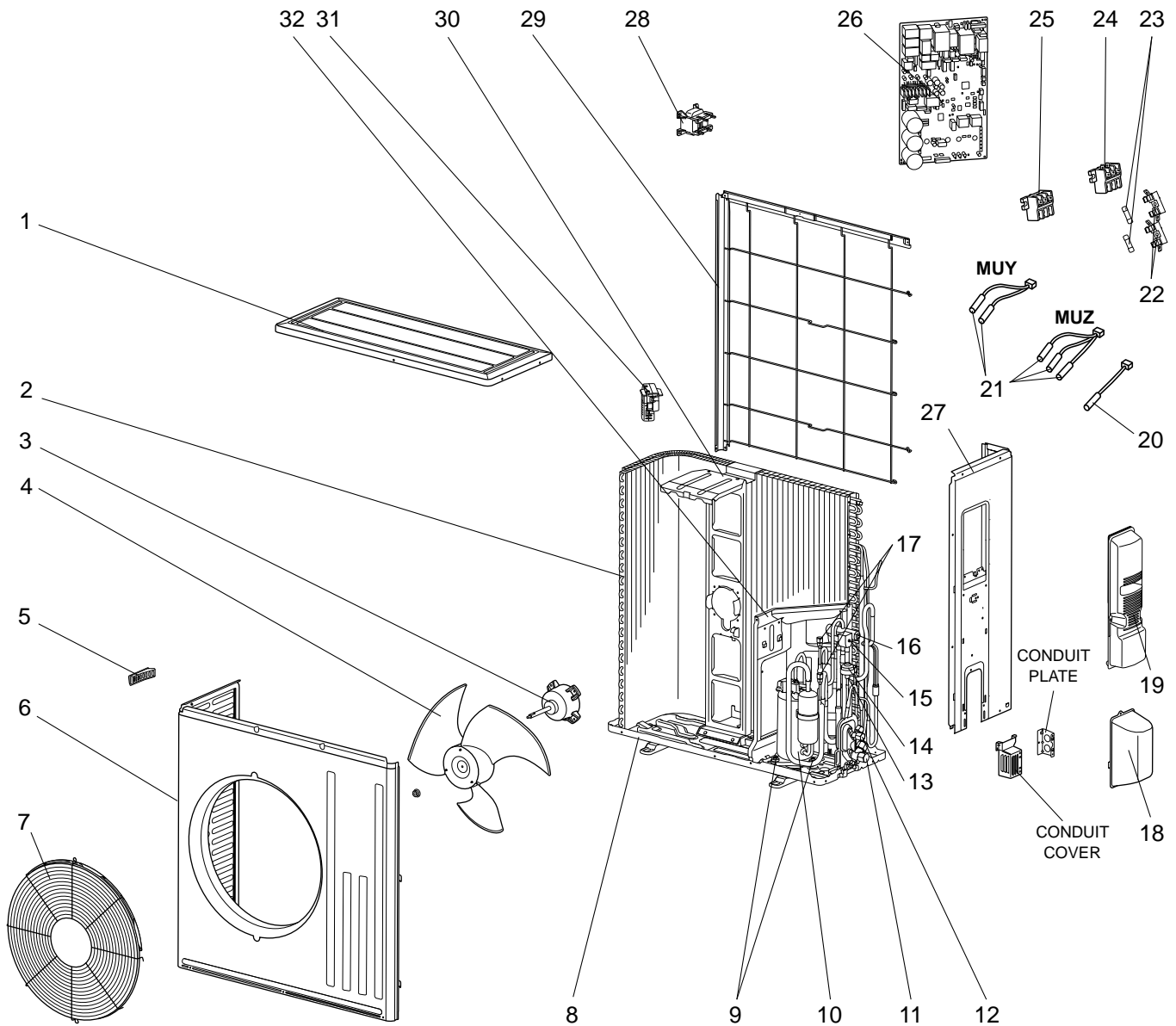

RoHS PARTS LIST

1-6. OUTDOOR UNIT STRUCTURAL PARTS, ELECTRICAL PARTS AND FUNCTIONAL PARTS

Part numbers that is circled is not shown in the illustration.

No.	RoHS	Part No.	Part Name	Symbol in Wiring Diagram	Q'ty/unit		Remarks
					MUZ-GE24NA	MUY-GE24NA	
1	G	E12 F28 297	TOP PANEL		1	1	
2	G	E12 J67 630	OUTDOOR HEAT EXCHANGER		1		
	G	E12 J43 630	OUTDOOR HEAT EXCHANGER			1	
3	G	E12 F76 301	OUTDOOR FAN MOTOR	MF	1	1	RC0J77-□□
4	G	E12 F28 501	PROPELLER		1	1	
5	G	E12 817 009	HANDLE		1	1	
6	G	E12 F28 232	CABINET		1	1	
7	G	E12 F73 521	FAN GUARD		1		Including ice guard
	G	E12 F28 521	FAN GUARD			1	
8	G	E12 F28 290	BASE		1	1	
9	G	E12 C34 506	COMPRESSOR RUBBER SET		3	3	3 RUBBERS/SET
10	G	E12 F76 900	COMPRESSOR	MC	1	1	SNB172FQKMT
11	G	E12 F76 661	STOP VALVE (GAS)		1	1	ø5/8
12	G	E12 F29 662	STOP VALVE (LIQUID)		1	1	ø3/8
13	G	E12 F28 493	EXPANSION VALVE COIL	LEV	1	1	
14	G	E12 853 640	EXPANSION VALVE		1	1	
15	G	E12 F76 490	R.V. COIL	21S4	1		
16	G	E12 A56 961	4-WAY VALVE		1	1	
17	G	E12 E79 641	SERVICE PORT		2	2	
18	G	E12 F28 650	VALVE COVER		1	1	
19	G	E12 J61 245	SERVICE PANEL		1	1	
20	G	E12 F76 309	AMBIENT TEMPERATURE THERMISTOR	RT65	1	1	
21	G	E12 F28 308	THERMISTOR SET	RT61,RT62, RT68	1		DEFROST, DISCHARGE, OUTDOOR HEAT EXCHANGER TEMPERATURE
	G	E12 F33 308	THERMISTOR SET	RT62, RT68		1	
22	G	E17 001 241	FUSE HOLDER		2	2	
23	G	E17 250 382	FUSE	F65, F66	2	2	T6.3AL250V
24	G	E12 L87 374	TERMINAL BLOCK	TB1	1	1	3 P
25	G	E12 F28 374	TERMINAL BLOCK	TB2	1	1	3 P
26	G	E12 P66 451	INVERTER P.C. BOARD		1		Including heat sink and RT64
	G	E12 J43 451	INVERTER P.C. BOARD			1	
27	G	E12 F76 233	BACK PANEL (OUT)		1	1	
28	G	E12 F28 337	REACTOR	L	1	1	
29	G	E12 L87 523	CONDENSER NET		1	1	
30	G	E12 J52 515	MOTOR SUPPORT		1	1	
31	G	E12 F76 079	THERMO HOLDER		1	1	
32	G	E12 F76 293	SEPARATOR		1	1	
33	G	E12 527 936	CAPILLARY TUBE (ø4.0×ø2.4×100)		1	1	O.D. 0.157 × I.D. 0.094× 3-15/16

2

OPTIONAL PARTS

2-1. DRAIN SOCKET

Model	Parts No.
MUZ-GE09NA	MAC-860DS
MUZ-GE09NA2	
MUZ-GE12NA	
MUZ-GE12NA2	
MUZ-GE15NA	
MUZ-GE15NA - ①	
MUZ-GE15NA2	

Model	Parts No.
MUZ-GE18NA	MAC-811DS
MUZ-GE18NA - ①	

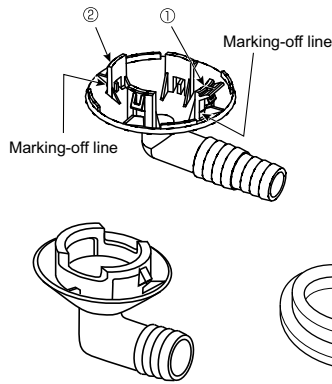

Installing a Drain Socket

For Φ 1-5/8 (Φ 42) hole
Put the tab ① in the hole first, and then the tab ②.

2-2. DEFROST HEATER

Model	Parts No.
MUZ-GE09NA	MAC-640BH-U
MUZ-GE09NA2	
MUZ-GE12NA	
MUZ-GE12NA2	
MUZ-GE15NA	
MUZ-GE15NA - ①	
MUZ-GE15NA2	

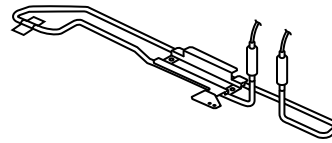

Components

① Defrost heater	1	④ Cable tie	1
② Aluminum tape	1	⑤ Self drilling screw	2
③ Heater support	1	⑥ Insulation	1

Model	Parts No.
MUZ-GE18NA	MAC-641BH-U
MUZ-GE18NA - ①	

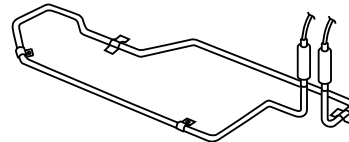

Components

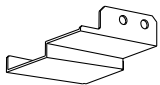
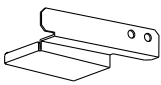
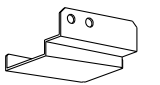
① Defrost heater	1	④ Cable tie	1	⑦ Heater cover A	1	⑧ Heater cover B	1	⑨ Heater cover C	1
② Aluminum tape	3	⑤ Self drilling screw	9						
③ Heater support	2	⑥ Clamp	1						

Note: Refer to the installation manual for the installation.

Model	Parts No.
MUZ-GE24NA	MAC-642BH-U

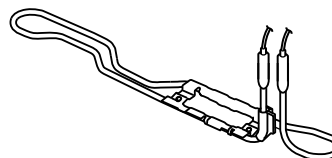

Components

① Defrost heater	1	④ Cable clamp	1
② Heater support	1	⑤ Self drilling screw	2
③ Cable tie	1	⑥ Wiring diagram	1

Note: Refer to the installation manual for the installation.

MITSUBISHI ELECTRIC CORPORATION

HEAD OFFICE: TOKYO BLDG., 2-7-3, MARUNOUCHI, CHIYODA-KU, TOKYO 100-8310, JAPAN

© Copyright 2009 MITSUBISHI ELECTRIC CORPORATION
Distributed in Nov. 2014. No. OBB549 REVISED EDITION-G
Distributed in Dec. 2013. No. OBB549 REVISED EDITION-F
Distributed in Apr. 2012. No. OBB549 REVISED EDITION-E
Distributed in Apr. 2011. No. OBB549 REVISED EDITION-D
Distributed in Apr. 2011. No. OBB549 REVISED EDITION-C
Distributed in Dec. 2010. No. OBB549 REVISED EDITION-B
Distributed in Sep. 2010. No. OBB549 REVISED EDITION-A 5
Distributed in Jul. 2009. No. OBB549 5
Made in Japan

New publication, effective Nov. 2014
Specifications are subject to change without notice.