

MU-A12WA-1

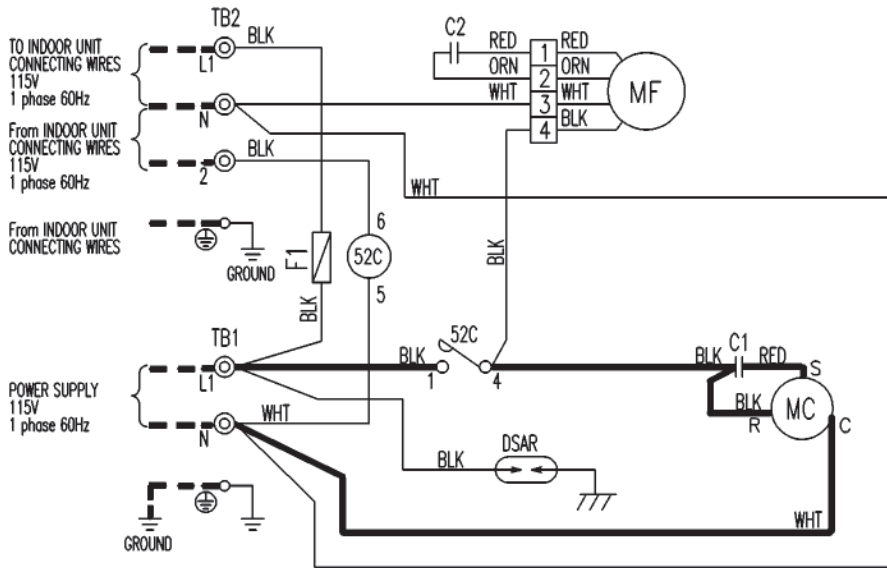

SYMBOL	NAME
C1	COMPRESSOR CAPACITOR
C2	FAN MOTOR CAPACITOR
DSAR	SURGE ABSORBER
F1	FUSE (AC250V, 3.15A)
MC	COMPRESSOR (INNER PROTECTOR)
MF	FAN MOTOR (INNER PROTECTOR)
TB1	TERMINAL BLOCK
TB2	TERMINAL BLOCK
52C	COMPRESSOR CONTACTOR

- NOTES: 1. About the indoor side electric wiring refer to the indoor unit electric wiring diagram for servicing.
 2. Use copper conductors only (For field wiring).
 3. Symbols below indicate.
 ○: Terminal block □: Connector

6 REFRIGERANT SYSTEM DIAGRAM

MU-A09WA

Unit : inch (mm)

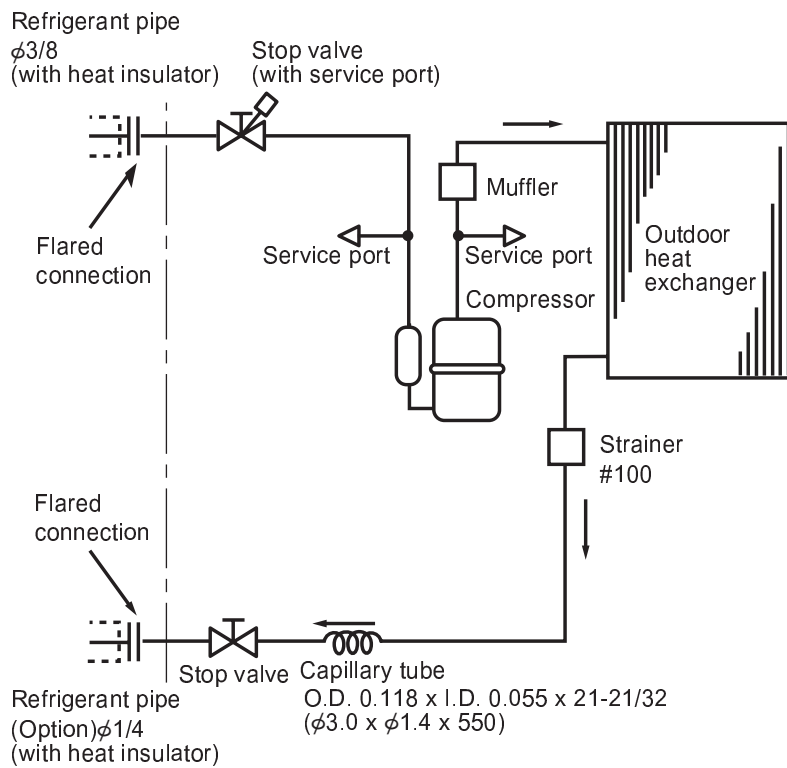

→ Refrigerant flow in cooling