

Job Name:	
System Reference:	Date:



Indoor Unit: MSZ-GE24NA



Wireless Remote Controller

**SPECIFICATIONS**

**Cooling Capacity\*** . . . . . 22,500 Btu/h  
**Heating Capacity\*** . . . . . 27,600 Btu/h

**\* Rating Conditions per AHRI Standard**

Cooling | Indoor: 80° F (27° C) DB / 67° F (19° C) WB  
 Cooling | Outdoor: 95° F (35° C) DB / 75° F (24° C) WB  
 Heating at 47° F | Indoor: 70° F (21° C) DB / 60° F (16° C) WB  
 Heating at 47° F | Outdoor: 47° F (8° C) DB / 43° F (6° C) WB

(For data on specific indoor units [all ducted, all non-ducted, and both ducted and non-ducted] combinations, see the MXZ Technical and Service Manual.)

Applications should be restricted to comfort cooling only; equipment cooling applications are not recommended for low ambient temperature conditions.

**GENERAL FEATURES**

- Wall-mounted indoor unit
- Nano Platinum and Anti-allergy Enzyme filters are included
- Quiet operation
- Auto fan speed control: Quiet, Low, Medium, High, and Super High
- Hand-held Wireless Remote Controller
- Indoor unit powered from outdoor unit using A-Control
- Auto restart following a power outage
- Limited warranty: five years parts and seven years compressor

**ACCESSORIES**

**Indoor Unit**

- Condensate Pump (BlueDiamond X87-711/721; 115/230V)
- Condensate Pump (Sauermann SI30-115/230; 115/230V)
- Anti-Allergy Enzyme Filter (MAC-2310FT-E)
- Drain Pan Level Sensor (DPLS2)

**Controller Options**

- Wireless Controller (MHK1)
- Wired Remote Controller PAR-31MAA (Requires MAC-333IF-E)
- Wireless Interface for kumo cloud™ (PAC-WHS01WF-E)
- Thermostat Interface (PAC-US444CN-1)

**Electrical Requirements**

Power Supply . . . . . 208 / 230V, 1-Phase, 60 Hz  
 MCA . . . . . 1 A

**Voltage**

Indoor - Outdoor S1-S2 . . . . . AC 208 / 230V  
 Indoor - Outdoor S2-S3 . . . . . DC ±24V  
 Indoor - Remote Controller . . . . . MHK1 DC 3V  
   PAR-31MAA DC 12V  
   PAC-YT53CRAU DC 12V

Blower Motor (ECM) . . . . . 0.76 F.L.A.

**Airflow (Quiet - Lo - Med - Hi - Super Hi)**

Cooling . . . . . 388 - 469 - 628 - 738 Dry CFM  
   347 - 420 - 562 - 661 Wet CFM  
 Heating . . . . . 388 - 469 - 628 - 738 Dry CFM

**Sound Pressure Level (Quiet - Lo - Med - Hi - Super Hi)**

Cooling . . . . . 34 - 41 - 49 - 53 dB(A)  
 Heating . . . . . 32 - 41 - 49 - 52 dB(A)

DIMENSIONS	UNIT INCHES / MM
W	43-5/16 / 1,116
D	9-3/8 / 238
H	12-13/16 / 325

Weight . . . . . 37 lbs. / 17 kg  
 External Finish . . . . . Munsell No. 1.0Y 9.2 / 0.2  
 Field Drainpipe Size O.D. . . . . 5/8" / 15.88 mm

Refrigerant Type . . . . . R410A

**Refrigerant Pipe Size O.D.**

Gas Side . . . . . 5/8" / 15.88 mm  
 Liquid Side . . . . . 3/8" / 6.35 mm

# DIMENSIONS: MSZ-GE24NA

Unit: inch

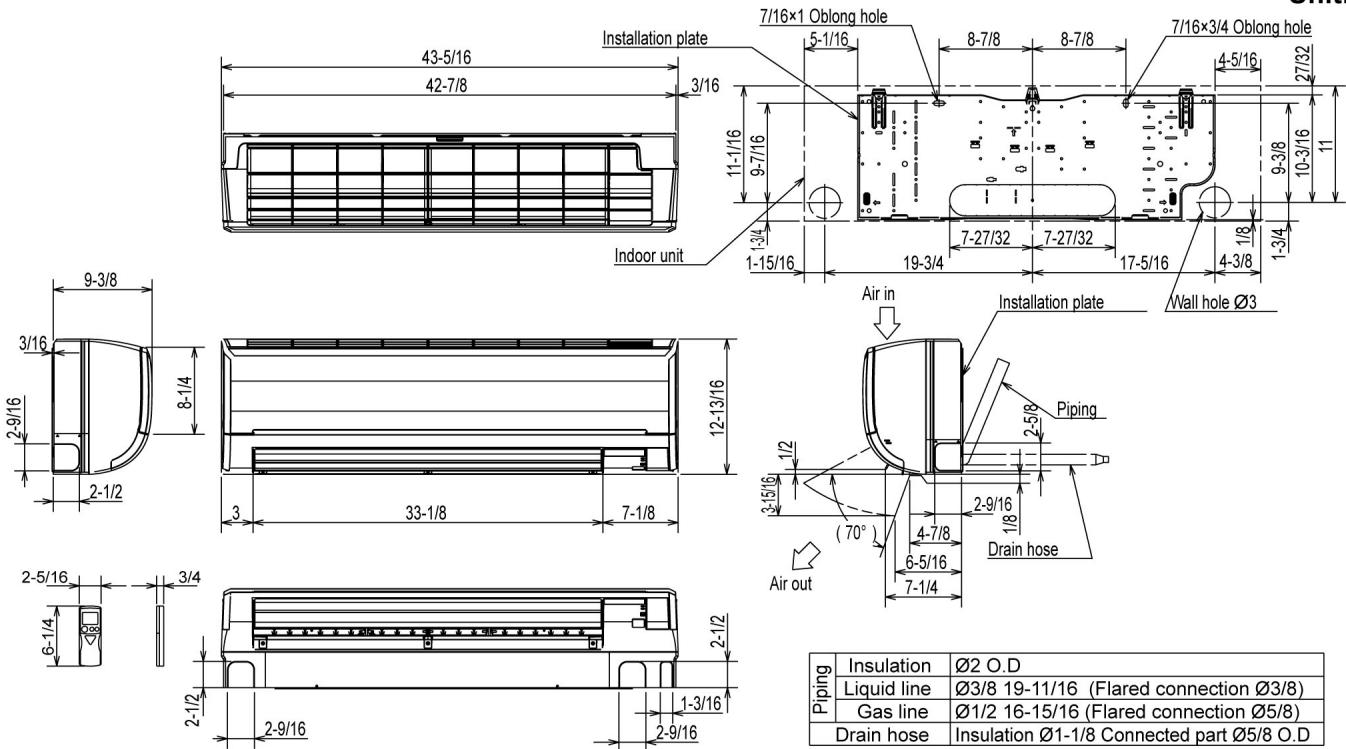

COOLING & HEATING

1340 Satellite Boulevard, Suwanee, GA 30024  
Toll Free: 800-433-4822 www.mehvac.com

