

SUBMITTAL DATA: MSZ-GE09NA-8 & MUZ-GE09NA2
9,000 BTU/H WALL-MOUNTED HEAT-PUMP SYSTEMS

Job Name:

System Reference:

Date:

GENERAL FEATURES

- Wall-mounted indoor unit
- Standard Hybrid Catechin Prefilter is included with indoor unit
- Quiet operation
- Auto fan speed control: Quiet, Low, Medium, High, and Super High
- Hand-held Wireless Remote Controller
- Indoor unit powered from outdoor unit using A-Control
- Auto restart following a power outage
- Anti-allergy Enzyme Filter
- Limited warranty: five years parts and seven years compressor

ACCESSORIES
Outdoor Unit

- Outdoor Mounting Pad (ULTRILITE1)
- Drain Pan Heater (MAC-640BH-U)
- 3-1/4" Mounting Base [Pair] (DSD-400P)
- Drain Pan Socket (MAC-860DS)
- Air Outlet Guide (MAC-889SG)
- Wall Mounting Bracket (CWMB1)

Indoor Unit

- BlueDiamond MaxiBlue Condensate Pump (X87-721, 230V)
- Sauermann Condensate Pump (SI30-230, 230V)
- Anit-Allergy Enzyme Filter (MAC-408FT-E)
- Platinum Catalyst Deodorizing Filter (MAC-308FT-E)
- Drain Pan Level Sensor (DPLS1)

Controller Options

- Wireless Wall-mounted Remote Controller Kit (MHK1)*
 - Portable Central Controller (MCCH1)*
 - Outdoor Air Sensor (MOS1)*
 - Wired Wall-mounted Controller (PAR-31MAA requires MAC-333IF)*
 - Simple MA Remote Controller (PAC-YT53CRAU requires MAC-333IF)*
- *See Submittal for information on each option.
- System Control Interface (MAC-333IF)

SPECIFICATIONS: MSZ-GE09NA-8 & MUZ-GE09NA2

Cooling *1

Rated Capacity.....9,000 Btu/h
Capacity Range.....3,800 - 12,200 Btu/h
Rated Total Input660 W
Maximum Total Input1,200 W
SEER23.2 Btu/h/W

Heating at 47° F *2

Rated Capacity.....10,900 Btu/h
Capacity Range.....4,500 - 14,100 Btu/h
Rated Total Input760 W
Maximum Total Input1,200 W
HSPF.....11.0 Btu/h/W

Heating at 17° F *3

Rated Capacity.....6,600 Btu/h
Maximum Capacity.....8,700 Btu/h
Rated Total Input700 W
Maximum Total Input950 W

Heating at 5° F

Maximum Capacity.....7,061 Btu/h

Rating Conditions:

- *1 Cooling | Indoor: 80° F (27° C) DB / 67° F (19° C) WB
- *1 Cooling | Outdoor: 95° F (35° C) DB / 75° F (24° C) WB
- *2 Heating at 47°F | Indoor: 70° F (21° C) DB / 60° F (16° C) WB
- *2 Heating at 47°F | Outdoor: 47° F (8° C) DB / 43° F (6° C) WB
- *3 Heating at 17° F | Indoor: 70° F (21° C) DB / 60° F (16° C) WB
- *3 Heating at 17° F | Outdoor: 17° F (-8° C) DB / 15° F (-9° C) WB
- *4 Heating at 5° F | Indoor: 70° F (21° C) DB / 60° F (16° C) WB
- *4 Heating at 5° F | Outdoor: 5° F (-15° C) DB / 5° F (-15° C) WB

Electrical Requirements

Power Supply208 / 230V, 1-Phase, 60 Hz
Breaker Size15 A

Voltage

Indoor - Outdoor S1-S2 AC 208 / 230V
Indoor - Outdoor S2-S3 DC +/- 24V
Indoor - Remote Controller MKH1 DC 3V
PAR-31MAA DC 12V
PAC-YT53CRAU DC 12V

Operating Conditions

Cooling

Indoor Intake Air Temp. . . (Max.) 90° F (32° C) DB / 73° F (23° C) WB
(Min.) 67° F (19° C) DB / 57° F (14° C) WB

Outdoor Intake Air Temp. (Max.) 115° F (46° C) DB
(Min.) 14° F (-10° C) DB

Heating

Indoor Intake Air Temp. . . (Max.) 80° F (27° C) DB / 67° F (19° C) WB
(Min.) 70° F (21° C) DB / 60° F (16° C) WB

Outdoor Intake Air Temp. (Max.) 75° F (24° C) DB / 65° F (18° C) WB
(Min.) -13° F (-25° C) DB / -15° F (-26° C) WB**

** System cuts out at -18° F (-28° C) to avoid thermistor error, but recovers from cutout operation and automatically restarts at -13° F (-25° C).

Indoor Unit

MCA.....1.0 A
Blower Motor (ECM).....0.76 F.L.A.
Blower Motor Output.....30 W

Airflow (Quiet - Lo - Med - Hi - Super Hi)

Cooling145-170-237-321-399 Dry CFM
109-134-201-286-364 Wet CFM
Heating.....145-170-237-321-406 Dry CFM

Sound Pressure Level (Quiet - Lo - Med - Hi - Super Hi)

Cooling19-22-30-37-43 dB(A)
Heating.....19-22-30-37-43 dB(A)

External Finish Color Munsell 1.0Y 9.2/0.2

Dimension Unit

Inches:.....11-5/8 H x 31-7/16 W x 9-1/8 D
mm:295 H x 798 W x 232 D

Weight Unit22 lbs. / 10kg

Field Drainpipe Size O.D.19/32" x 15 mm

Outdoor Unit

MCA.....12 A
Fan Motor (ECM).....0.50 F.L.A.

Sound Pressure Level

Cooling *1.....46 dB(A)
Heating *250 dB(A)

External Finish Color Munsell 3Y 7.8/1.1

External Dimensions

Inches:.....21-5/8 H x 31-1/2 W x 11-1/4 D
mm:550 H x 800 W x 285 D

Weight66 lbs. / 30kg

Refrigerant Type R410A

Refrigerant Pipe

Gas Side O.D.3/8 " / 9.52 mm
Liquid Side O.D.1/4" / 6.35 mm

Refrigerant Pipe Length

Height Difference (Max.)40' / 12 m
Length (Max.)65' / 20 m

Connection Method

Indoor/Outdoor Flared

Notes:

DIMENSIONS: MSZ-GE09NA-8 & MUZ-GE09NA2

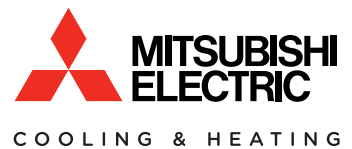
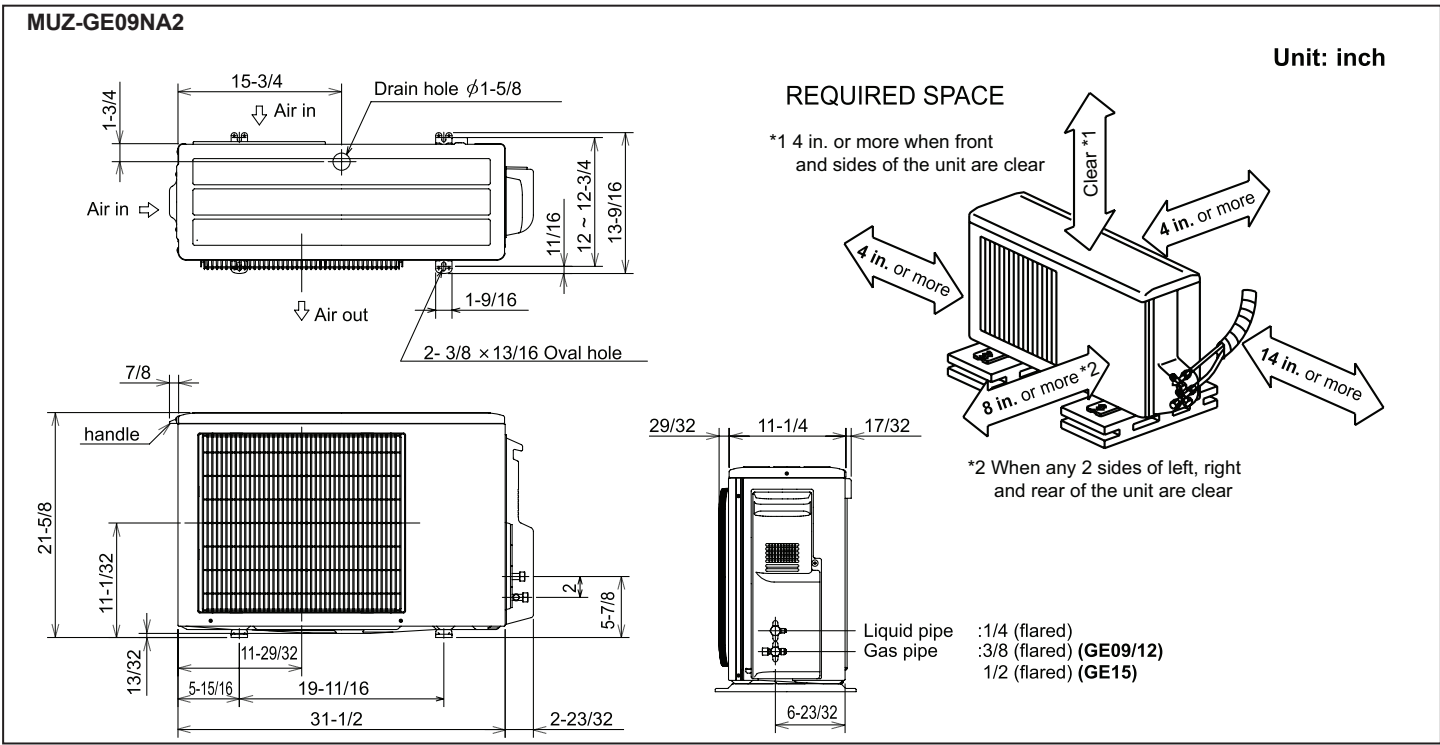
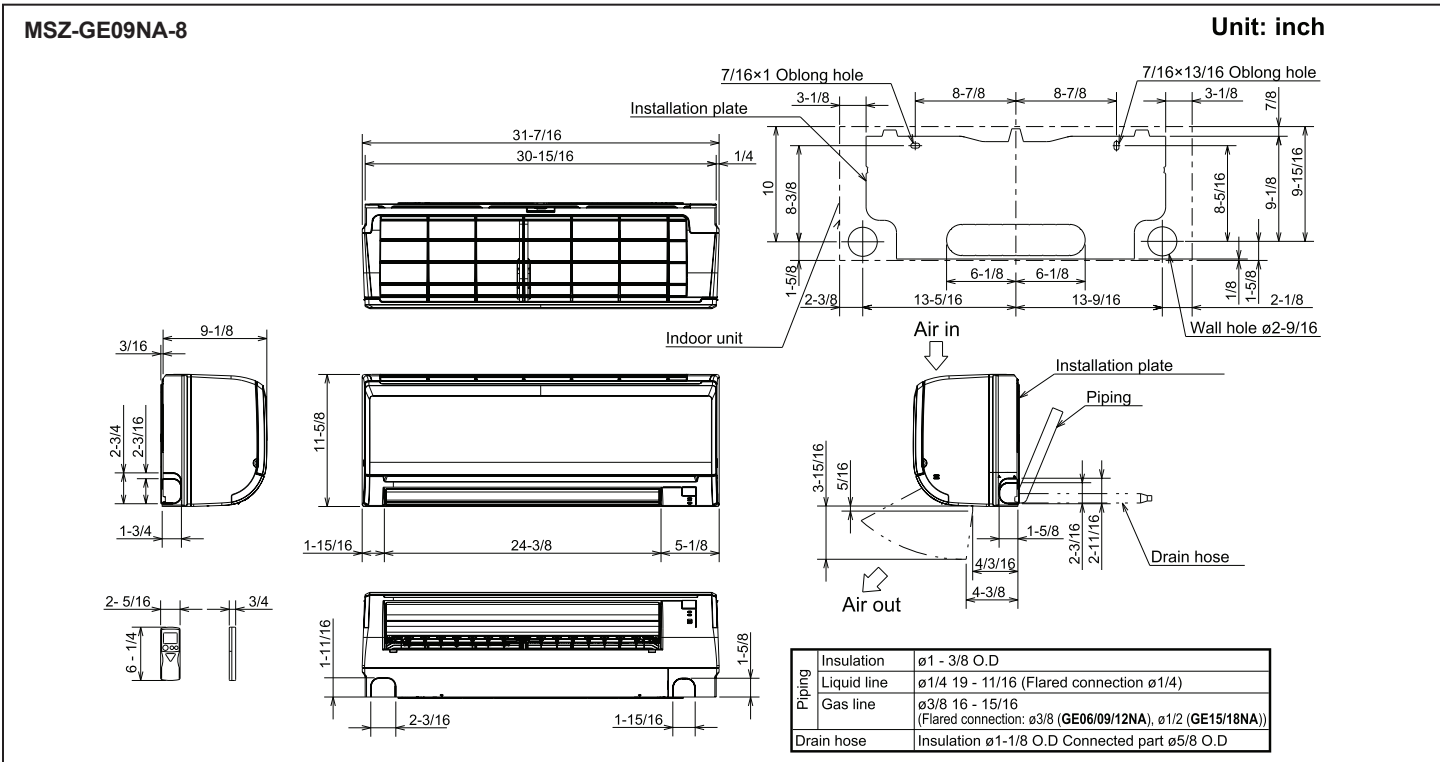

1340 Satellite Boulevard
Suwanee, GA 30024
Tele: 678-376-2900 • Fax: 800-889-9904
Toll Free: 800-433-4822
www.mehvac.com