

SUBMITTAL DATA: MS-A12WA & MU-A12WA****
 12,000 BTU/H WALL-MOUNTED AIR-CONDITIONING SYSTEMS

Job Name:	Location:	Date:
Purchaser:	Engineer:	
Submitted to:	For <input type="checkbox"/> Reference <input type="checkbox"/> Approval <input type="checkbox"/> Construction	
System Designation:	Schedule No.:	

****APPLIES TO INDOOR UNIT:**

- MS-A12WA
- MS-A12WA-1

****APPLIES TO OUTDOOR UNIT:**

- MU-A12WA
- MU-A12WA-1



Indoor Unit: MS-A12WA**



Outdoor Unit: MU-A12WA**



Wireless Remote Controller

GENERAL FEATURES

- Wall-mounted indoor unit for residential applications
- Compact side discharge outdoor unit
- Zone control
- Quiet operation for both indoor and outdoor units
- "Powerful Mode" function permits system to temporarily run at a lower/higher temperature with an increased fan speed, which quickly brings the room to the optimum comfort level
- Wireless remote controller is included
- Indoor unit powered from outdoor unit using A-Control
- Automatic restart following a power outage
- Self-check function — onboard diagnostics
- Dry Mode function is standard
- Limited warranty: five years parts and seven years compressors

ACCESSORIES
Outdoor Unit

- Low-ambient Head-pressure Controller (ICM-326HM-1)

Indoor Unit

- Condensate Pump (115V; SI3100-115)

SPECIFICATIONS
Cooling*

Rated Capacity 12,000 Btu/h
 SEER 13.0
 Total Input 1,070 W
 * Rating Conditions (Cooling) - Indoor: 80° F (27° C) DB, 67° F (19° C) WB;
 Outdoor: 95° F (35° C) DB, 75° F (24° C) WB.

Power Supply 115V, 1-Phase, 60 Hz
 Breaker Size 20 A

Voltage

Indoor - Outdoor L1-N AC 115V
 Indoor - Outdoor L2 AC 115V
 Indoor - Remote Controller Wireless

OPERATING RANGE

		Indoor Intake Air Temp.	Outdoor Intake Air Temp.
Cooling	Maximum	95° F (35° C) DB, 71° F (22° C) WB	115° F (46° C) DB
	Minimum	67° F (19° C) DB, 57° F (14° C) WB	67° F (19° C) DB

Indoor Unit

MCA 1.2 A
 Fan Motor 0.95 F.L.A.
 Airflow (Lo - Med - Hi - Powerful)
 Cooling 222 - 286 - 406 - 446 Dry CFM
 198 - 254 - 363 - 399 Wet CFM

Sound Pressure Level (Lo - Med - Hi - Powerful)

Cooling 33 - 38 - 45 - 47 dB(A)

DIMENSIONS	UNIT INCHES / MM
W	30-11/16 / 780
D	8-1/4 / 210
H	11-3/4 / 299

Weight 23 lbs. / 10 kg
 External Finish Munsell No. 3Y 7.8 / 1.1
 Field Drainpipe Size O.D. 5/8" / 15.88 mm
 Remote Controller Wireless

Outdoor Unit

Compressor Single Rotary
 MCA 16 A
 Fan Motor 0.93 F.L.A.
 Sound Pressure Level
 Cooling 52 dB(A)

DIMENSIONS	INCHES / MM
W	33-7/16 / 849
D	11-7/16 / 291
H	23-13/16 / 605

Weight 96 lbs. / 44 kg
 External Finish Munsell 3Y 7.8 / 1.1

Refrigerant Type R410A
 Refrigerant Pipe Size O.D.
 Gas Side 1/2" / 12.7 mm
 Liquid Side 1/4" / 6.35 mm
 Max. Refrigerant Pipe Length 65 ft. / 19 m
 Max. Refrigerant Pipe Height Difference 35 ft. / 11 m
 Connection Method Flared

DIMENSIONS: MS-A12WA** & MU-A12WA**

MS-A12WA**

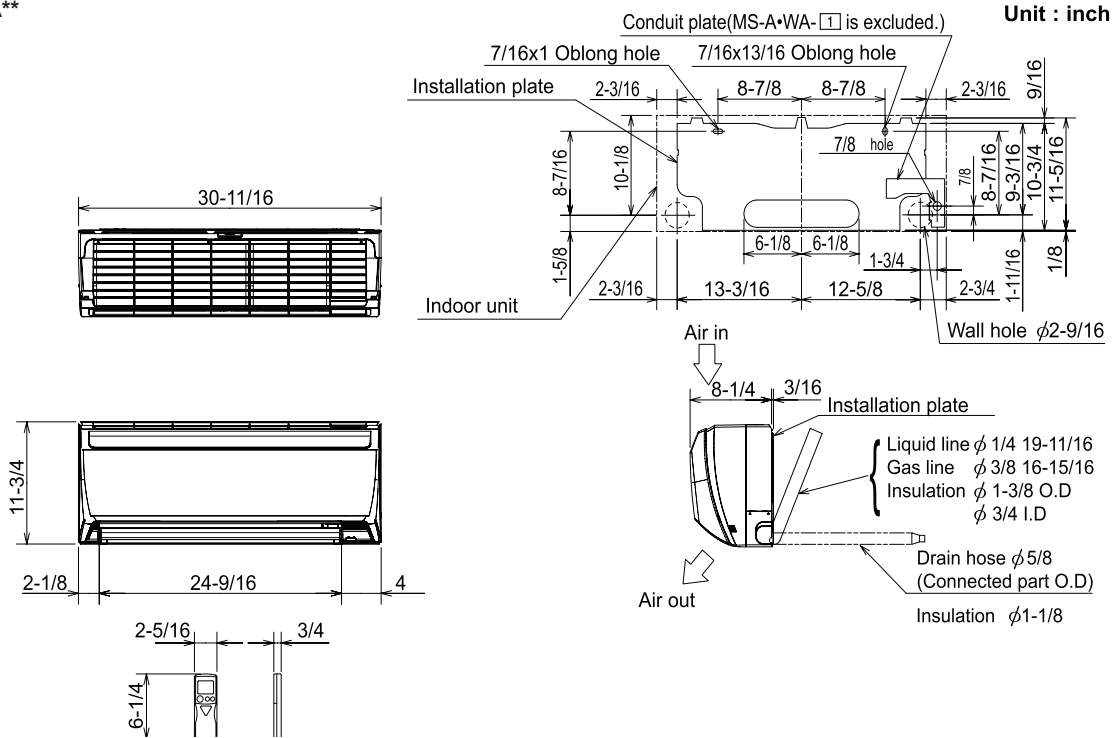

MU-A12WA**

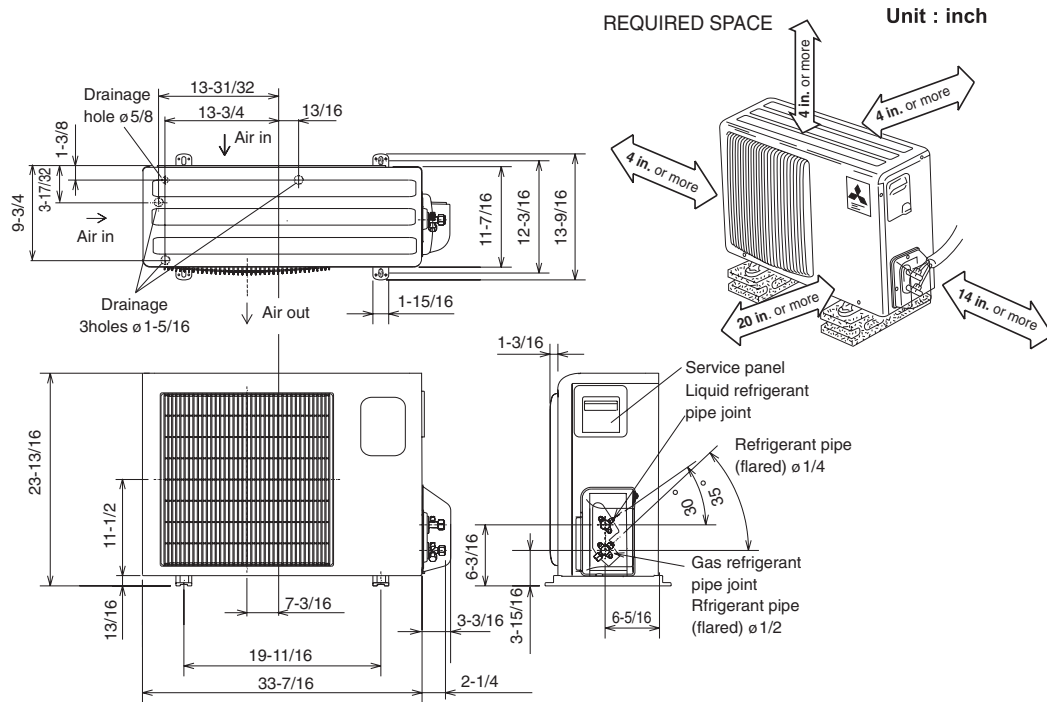

Intertek

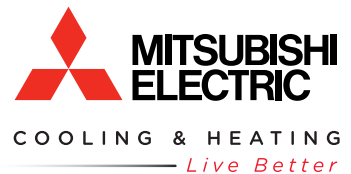

1340 Satellite Boulevard
 Suwanee, GA 30024
 Tele: 678-376-2900 • Fax: 800-889-9904
 Toll Free: 800-433-4822
 www.mehvac.com