

**SUBMITTAL DATA: MS-A09WA\*\* & MU-A09WA**

9,000 BTU/H WALL-MOUNTED AIR-CONDITIONING SYSTEMS

Job Name:	Location:	Date:
Purchaser:	Engineer:	
Submitted to:	For <input type="checkbox"/> Reference <input type="checkbox"/> Approval <input type="checkbox"/> Construction	
System Designation:	Schedule No.:	

**\*\*APPLIES TO INDOOR UNIT:**

- MS-A09WA
- MS-A09WA-1



Indoor Unit: MS-A09WA\*\*



Outdoor Unit: MU-A09WA



Wireless Remote Controller

**GENERAL FEATURES**

- Wall-mounted indoor unit for residential applications
- Compact side discharge outdoor unit
- Zone control
- Quiet operation for both indoor and outdoor units
- "Powerful Mode" function permits system to temporarily run at a lower/higher temperature with an increased fan speed, which quickly brings the room to the optimum comfort level
- Wireless remote controller is included
- Indoor unit powered from outdoor unit using A-Control
- Automatic restart following a power outage
- Self-check function — onboard diagnostics
- Dry Mode function is standard
- Limited warranty: five years parts and seven years compressors

**ACCESSORIES**
**Outdoor Unit**

- Low-ambient Head-pressure Controller (ICM-326HM-1)

**Indoor Unit**

- Condensate Pump (115V; SI3100-115)

**SPECIFICATIONS**
**Cooling\***

Rated Capacity . . . . . 9,500 Btu/h  
 SEER . . . . . 13.0  
 Total Input . . . . . 870 W  
 \* Rating Conditions (Cooling) - Indoor: 80° F (27° C) DB, 67° F (19° C) WB;  
 Outdoor: 95° F (35° C) DB, 75° F (24° C) WB.

Power Supply . . . . . 115V, 1-Phase, 60 Hz  
 Breaker Size . . . . . 15 A

**Voltage**

Indoor - Outdoor L1-N . . . . . AC 115V  
 Indoor - Outdoor L2 . . . . . AC 115V  
 Indoor - Remote Controller . . . . . Wireless

**OPERATING RANGE**

		Indoor Intake Air Temp.	Outdoor Intake Air Temp.
Cooling	Maximum	95° F (35° C) DB, 71° F (22° C) WB	115° F (46° C) DB
	Minimum	67° F (19° C) DB, 57° F (14° C) WB	67° F (19° C) DB

**Indoor Unit**

MCA . . . . . 1.2 A  
 Fan Motor . . . . . 0.95 F.L.A.  
 Airflow (Lo - Med - Hi - Powerful)  
 Cooling . . . . . 183 - 261 - 335 - 367 Dry CFM  
 162 - 233 - 300 - 328 Wet CFM  
 Sound Pressure Level (Lo - Med - Hi - Powerful)  
 Cooling . . . . . 26 - 32 - 40 - 42 dB(A)

DIMENSIONS	UNIT INCHES / MM
W	30-11/16 / 780
D	8-1/4 / 210
H	11-3/4 / 299

Weight . . . . . 23 lbs. / 10 kg  
 External Finish . . . . . Munsell No. 3Y 7.8 / 1.1  
 Field Drainpipe Size O.D. . . . . 5/8" / 15.88 mm  
 Remote Controller . . . . . Wireless

**Outdoor Unit**

Compressor . . . . . Single Rotary  
 MCA . . . . . 14 A  
 Fan Motor . . . . . 0.63 F.L.A.  
 Sound Pressure Level  
 Cooling . . . . . 47 dB(A)

DIMENSIONS	INCHES / MM
W	31-1/2 / 800
D	11-1/4 / 286
H	21-5/8 / 549

Weight . . . . . 78 lbs. / 35 kg  
 External Finish . . . . . Munsell 3Y 7.8 / 1.1

Refrigerant Type . . . . . R410A  
 Refrigerant Pipe Size O.D.  
 Gas Side . . . . . 3/8" / 9.5 mm  
 Liquid Side . . . . . 1/4" / 6.35 mm  
 Max. Refrigerant Pipe Length . . . . . 65 ft. / 19 m  
 Max. Refrigerant Pipe Height Difference . . . . . 35 ft. / 11 m  
 Connection Method . . . . . Flared



# DIMENSIONS: MS-A09WA\*\* & MU-A09WA

## MS-A09WA\*\*

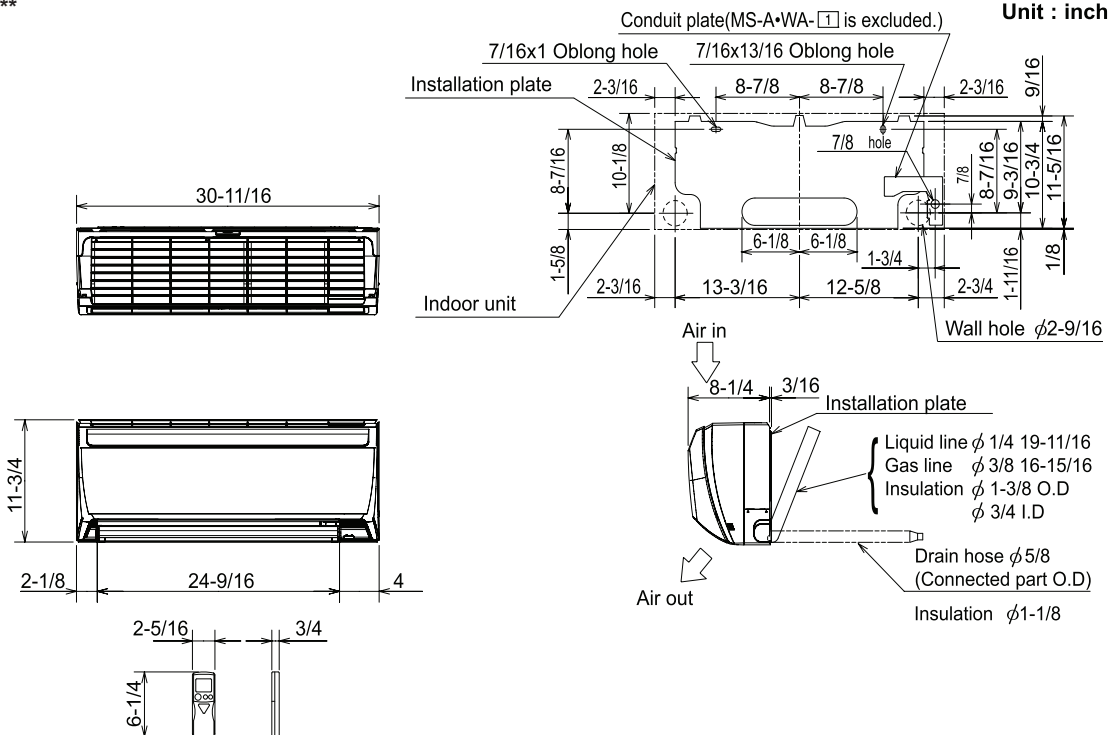

## MU-A09WA

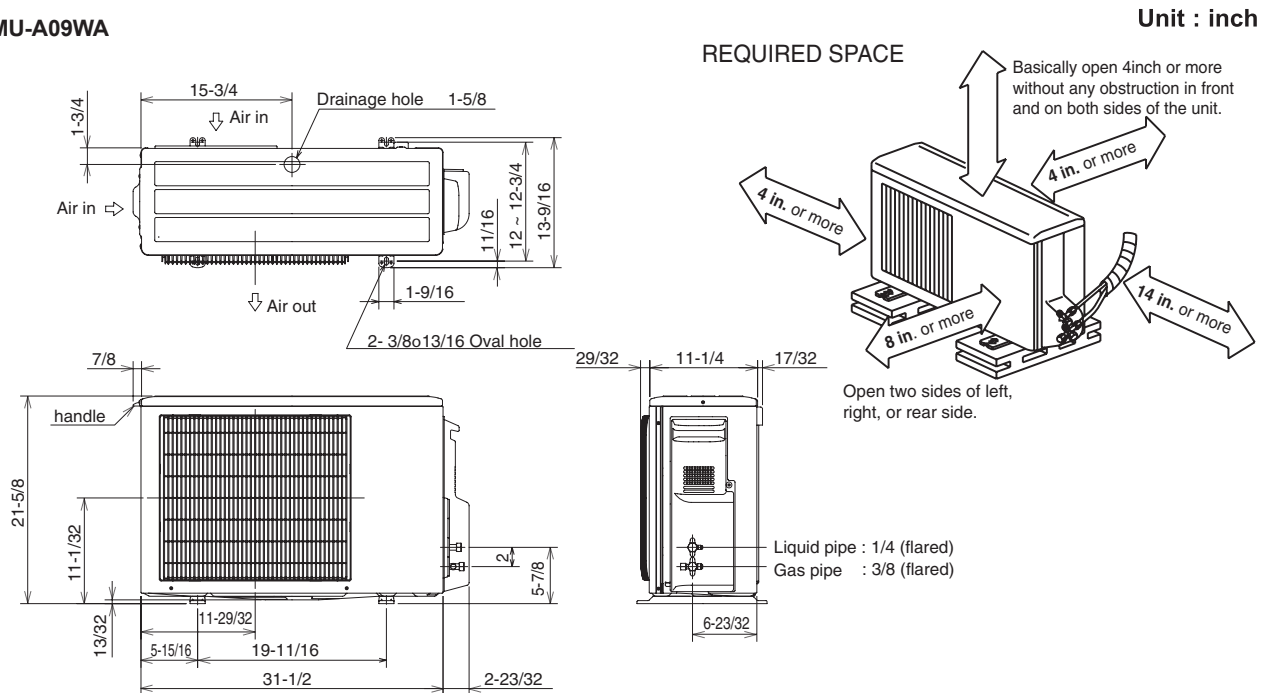

**Intertek**



1340 Satellite Boulevard  
Suwanee, GA 30024  
Tele: 678-376-2900 • Fax: 800-889-9904  
Toll Free: 800-433-4822  
www.mehvac.com