



STANDARD CONSTRUCTION

FRAME:

16 GAUGE 1" X 1" SQUARE TUBE
 16 GAUGE 1" X 1" STEEL ANGLE
 20 GAUGE 1/2" X 1/2" STEEL ANGLE

OUTSIDE CASING:

16 GAUGE ASTM A-653 HOT-DIPPED GALVANIZED STEEL SHEET
 22 GAUGE ASTM A-653 HOT-DIPPED GALVANIZED STEEL SHEET

MESH:

13 GAUGE 1 3/4" X 3/4" EXPANDED STEEL

STANDARD SIZES:

MODEL	WIDTH	DEPTH	HEIGHT	QTY
TASB175	17 5/8"	21"	17 1/4"	1
TASB215	21 5/8"	21"	17 1/4"	1
TASB235	23 5/8"	21"	17 1/4"	1

FEATURES

GALVANIZED STEEL PROVIDES EXCELLENT CORROSION RESISTANCE AND LONGEVITY.

FULLY POWDER COATED TO GIVE A LONG LASTING, CORROSION RESISTANT FINISH ("GRANITE GREY," RAL 7026).

PLASTIC CAPPED FEET TO PROTECT FLOOR SURFACE.

PRE-FILTER TRACK ACCOMMODATES A 1" THICK AIR FILTER (FILTER NOT INCLUDED).

STANDS INDIVIDUALLY BOXED FOR EASY INVENTORY.

1" PRE-FILTER TRACK

FOR TASB WITH OPTIONAL BAFFLE KIT FACTORY INSTALLED (TAS\$BK), ADD "SB" TO PART NUMBER (i.e. TASB235SB).

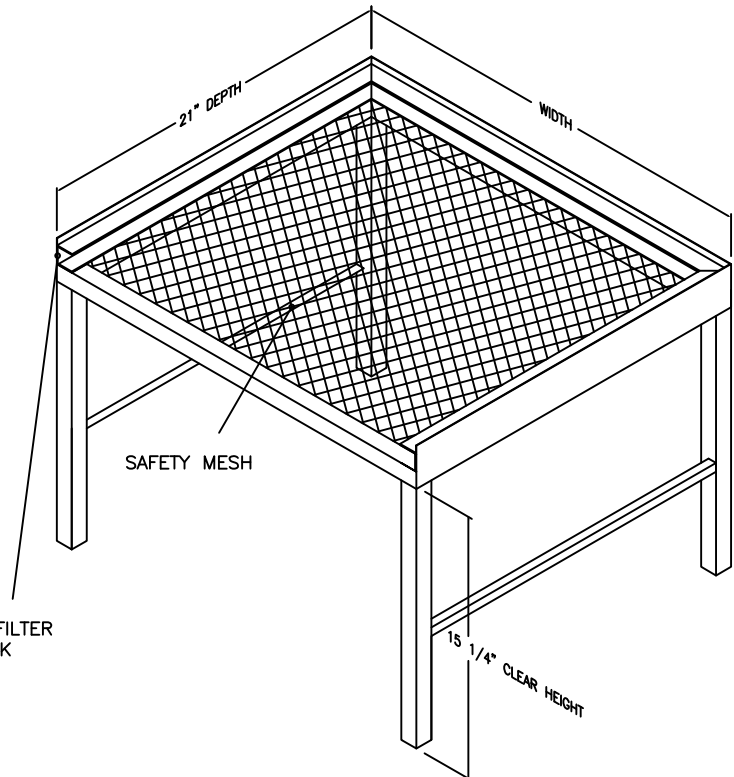

JOB NAME:
LOCATION:
ARCHITECT:
ENGINEER:
CONTRACTOR:
<p>CONTACT MIAMI TECH INC. FOR ADDITIONAL INFORMATION OR WITH SPECIAL REQUIREMENTS.</p> <p>3611 NW 74TH ST MIAMI, FL 33147 PHONE: 305-693-7054 FAX: 305-693-6152</p> <p>WEB: WWW.MIAMITECH.COM EMAIL: SALES@MIAMITECH.COM</p>

TASB

TRANE/AMERICAN STANDARD AIR HANDLER STAND
 PRODUCT SPECIFICATIONS

NOTE: ALL DRAWINGS SUBJECT TO CHANGE WITHOUT PRIOR NOTICE.



DRAWN BY: AF	DATE: 11/08/07	SCALE: NOT TO SCALE	DRAWING NO.
CHECKED BY: AV	DATE: 2/15/12	REVISION: F	TASB