

Installation Instructions for Roof Mount Tie-Down Kit

New Platform Rheem & Ruud Outdoor Units

Kit Number: RRCUTD34K

- 1) Center unit on roof mounted I-beams in the desired orientation. The I-beams must be at least 20" apart on center.
- 2) Refer to installation drawing on the reverse side of this sheet for steps 3 – 9.
- 3) Place the (2) of the 2" x 1" aluminum angles included in kit across the I-beams and against the unit base on opposite sides of the unit as shown in details 1, 2, and 5. Orient the 1" tall section of the angle against the unit and the 2" wide section of the angle on the I-beams.
- 4) Note: Clamps are recommended for holding the angle frame in place while drilling through the angles and I-beams.
- 5) Drill a 3/8" diameter hole through each of the 2" x 1" aluminum angles where they rest on the I-beams (total of 4 holes) and then through the top flange of the I-beam as shown in detail 3.
- 6) Insert 3/8" bolts included with the kit through the holes in the angle and I-beam, placing the washers under the head of the bolt and between the nut and I-beam flange as shown in detail 3. Tighten the nuts using a back-up wrench on the bolt head.
- 7) Attach each of the four (4) steel "L" brackets included in kit to the sides of the louver panels with seven (7) #10 x 3/4" self-drilling screws included with the kit per details 4 and 5. Be sure the bottom of "L" brackets are resting on the angles before attaching the brackets to the louver panels with screws. Please note the brackets are attached to the posts, not the louver panels, to maintain the ability to easily remove the louver panels when servicing the unit.
- 8) Using the hole in the bottom of each "L" bracket as a guide, drill a 1/4" diameter hole through the aluminum angle for the 1/4" bolts that will secure the four (4) brackets to the 2" x 1" angles.
- 9) Insert the 1/4" bolts included with the kit through the hole in each bracket and angle, placing the washers under the head of the bolt and between the nut and angle as shown in detail 4. Tighten the nuts using a back-up wrench on the bolt head.

RHEEM SALES COMPANY, INC.

WIND LOAD CERTIFICATION OF MECHANICAL UNIT CABINETY AND STEEL TIE-DOWN CLIPS: ROOF MOUNTED APPLICATIONS

FRANK BENNARDO, P.E.
#PE46549

06/10/2015

VALID FOR 1 PERMIT ONLY U.N.C.
VALID ONLY WITH ORIGINAL ENGINEER SEAL

ENGINEERING EXPRESS
160 SW 12th AVENUE, #106
DEERFIELD BEACH, FL 33442
Ph: (954) 354-0660 Fax: (954) 354-0443
WWW.ENGEXP.COM
CERT OF AUTH #9885
A FRANK L. BENNARDO, P.E., INC. INNOVATION

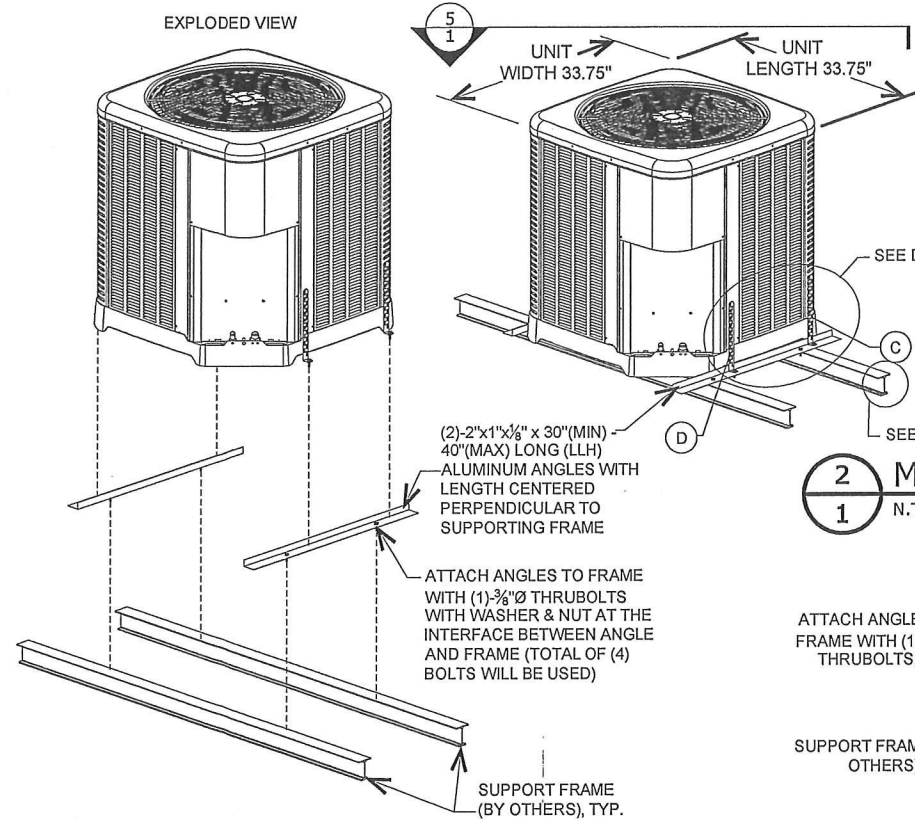

1 MOUNT EXPLODED VIEW
1 N.T.S. FRONT ISOMETRIC

2 MOUNT ISOMETRIC VIEW
1 N.T.S. FRONT ISO / BACK ISO

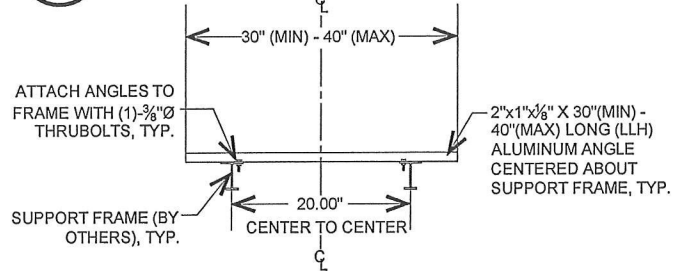

3 SUPPORT ANGLE
1 N.T.S. ELEVATION

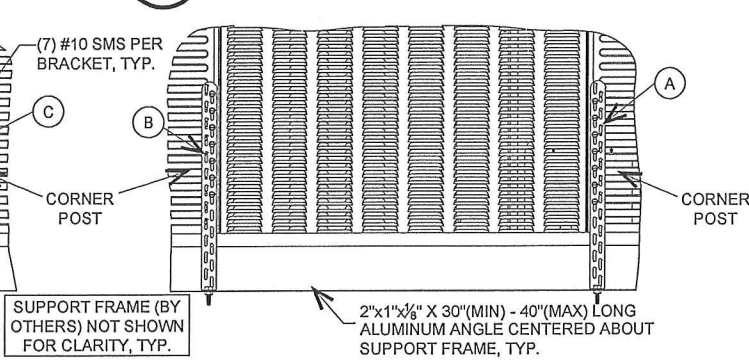

4 TIE-DOWN BRACKET ATTACHMENTS
1 N.T.S. ELEVATIONS

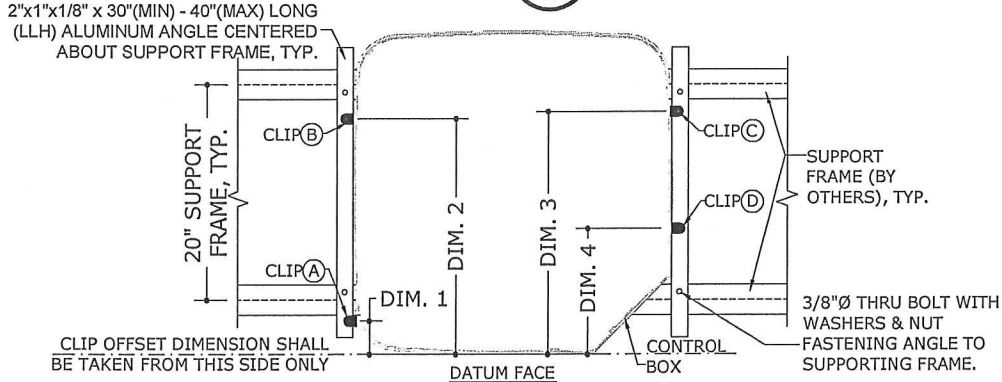

5 TIE-DOWN BRACKET LAYOUT
1 N.T.S. PLAN

NOTE: UNIT SHALL BE CENTERED ABOUT THE 20" RAIL TO RAIL SUPPORTING FRAME (BY OTHERS)

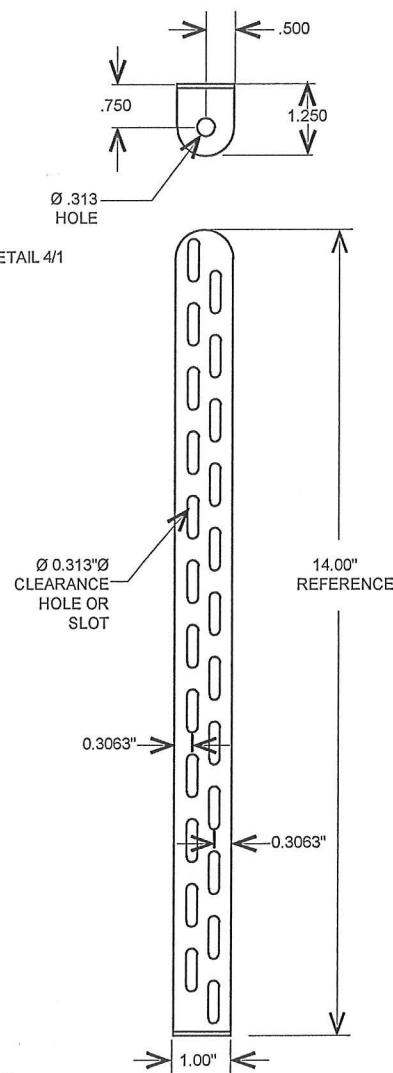

TIE-DOWN BRACKET

MIAMI TECH CLIP: 12GA (0.09") ASTM A653 Fu=90 KSI STEEL (CUTD14), MIAMI TECH KIT # RRCUTD34K

TIE-DOWN BRACKET OFFSETS:

DIM. 1	4.50" MAX OFFSET FROM DATUM FACE
DIM. 2	28.00" MIN OFFSET FROM DATUM FACE
DIM. 3	29.00" MIN OFFSET FROM DATUM FACE
DIM. 4	13.00" MAX OFFSET FROM DATUM FACE

APPLICABLE MODELS:

RA1348, RA1436, RA1442B, RA1624, RA1636B, RA1642B, RP1336, RP1348, RP1436, RP1442, RP1448, RP1530, RD1430 RP1536, RD1436, RP1542, RD1442, RA/UA1724, RA/UA2036, RA/UA2024 RP/UP1724, RP/UP1736, RA/UA1736 RP/UP2024

APPROVED DESIGN CRITERIA:

THE FOLLOWING ARE APPROVED INSTALLATION SCENARIOS FOR THE SYSTEM ILLUSTRATED HEREIN:

SCENARIO	ULTIMATE WIND SPEED	EXPOSURE	MEAN ROOF HEIGHT†	CENTROID HEIGHT*
1	175 MPH++	C	210 FT	56"
2	175 MPH++	D	130 FT	56"

*CENTROID HEIGHT IS THE HEIGHT OF THE UNIT'S GEOMETRIC CENTROID ABOVE THE LISTED MEAN ROOF HEIGHT. THE SYSTEM ILLUSTRATED HEREIN IS APPROVED FOR INSTALLATIONS TO ROOFTOP STANDS (BY OTHERS) UP TO 30" IN HEIGHT.

†MEAN ROOF HEIGHT OF THE BUILDING TO WHICH THE UNIT IS BEING INSTALLED

‡ALLOWABLE WIND SPEED (Vasd)=135.6 MPH

DESIGN NOTES:

THIS SYSTEM HAS BEEN DESIGNED IN ACCORDANCE WITH ASCE 7-10 AND THE FLORIDA BUILDING CODE FIFTH EDITION (2014) FOR USE WITHIN AND OUTSIDE THE HIGH VELOCITY HURRICANE ZONE AS INDICATED IN THE ACCOMPANYING DESIGN SCHEDULES. THE DESIGN CRITERIA USED TO CALCULATE THE ALLOWABLE ROOF-TOP HEIGHTS CONSIDERS ASCE 7-10 SECTION 29.5 FOR ROOF TOP HEIGHTS (H)>60 FT. (GC_L)_{Lateral}=1.90 OUTSIDE THE HVHZ, (GC_L)_{Uplift}=1.5 FOR ALL LOCATIONS (CONCURRENT). (GC_L)_{Lateral}=3.10 WITHIN THE HVHZ PER FBC 1620.6 (CONCURRENT WITH (GC_L)_{Uplift}). ALL OTHER DESIGN VARIABLES ARE IN ACCORDANCE WITH ASCE 7-10 CHAPTERS 26 & 29.

GENERAL NOTES:

- THIS SYSTEM HAS BEEN DESIGNED AND SHALL BE FABRICATED IN ACCORDANCE WITH THE REQUIREMENTS OF THE FLORIDA BUILDING CODE FIFTH EDITION (2014) & ASCE 7-10. THIS SYSTEM MAY BE USED WITHIN AND OUTSIDE THE HIGH VELOCITY HURRICANE ZONE. THIS DESIGN IS NOT INTENDED TO CERTIFY IMPACT RESISTANCE OF THE MECHANICAL UNIT CABINETY.
- NO 33-1/3% INCREASE IN ALLOWABLE STRESS HAS BEEN USED IN THE DESIGN OF THIS SYSTEM.
- DESIGN & CERTIFICATION OF THE UNIT CABINETY IS APPROVED THROUGH TEST REPORT #0323.01-15 BY AMERICAN TEST LAB OF SOUTH FLORIDA.
- ALL DIMENSIONS AND THE MINIMUM WEIGHT (199LB MINIMUM) OF MECHANICAL UNIT SHALL CONFORM TO LIMITATIONS STATED HEREIN. ALL MECHANICAL SPECIFICATIONS (CLEAR SPACE, TONNAGE, ETC.) SHALL BE AS PER MANUFACTURER RECOMMENDATIONS AND ARE THE EXPRESS RESPONSIBILITY OF THE CONTRACTOR.
- ALL SHEET METAL SCREWS USED TO FASTEN BRACKETS TO MECHANICAL UNITS SHALL BE #10 (14 MIN THREADS PER INCH) ASTM F593 410 STAINLESS STEEL OR EQUIVALENT ONLY. BOLTS USED TO FASTEN ALUMINUM ANGLES TO SUPPORTING FRAME (BY OTHERS) SHALL BE ASTM F593 410 STAINLESS STEEL OR EQUIVALENT AND SHALL UTILIZE SAE GRADE WASHERS & NUTS. PROVIDE (5) PITCHES MINIMUM PAST THE THREAD PLANE FOR SHEET METAL SCREWS. ALL FASTENERS SHALL HAVE APPROPRIATE CORROSION PROTECTION TO PREVENT ELECTROLYSIS. ALL FASTENER CONNECTIONS TO ALUMINUM SHALL PROVIDE 2xDIAMETER EDGE DISTANCE.
- ALUMINUM ANGLES SPECIFIED HEREIN SHALL BE 6061-T6 ALUMINUM ONLY.
- CONNECTIONS TO THE SUPPORTING FRAME (BY OTHERS) CONSIDER A FRAME MEMBER THAT IS 6061-T6 MIN ALUMINUM WITH A MINIMUM 0.094" THICK FLANGE AT ATTACHMENT POINT. PERFORMANCE OF THE RAIL AS A STRUCTURAL MEMBER TO SUPPORT THE UNIT ASSEMBLY SHALL BE PER SEPARATE CERTIFICATION.
- THE CONTRACTOR IS RESPONSIBLE TO INSULATE ALL MEMBERS FROM DISSIMILAR MATERIALS TO PREVENT ELECTROLYSIS.
- ELECTRICAL GROUND, WHEN REQUIRED, TO BE DESIGNED & INSTALLED BY OTHERS.
- THE ADEQUACY OF ANY EXISTING STRUCTURE TO WITHSTAND SUPERIMPOSED LOADS SHALL BE VERIFIED BY THE ONSITE DESIGN PROFESSIONAL AND IS NOT INCLUDED IN THIS CERTIFICATION. EXCEPT AS EXPRESSLY PROVIDED HEREIN, NO ADDITIONAL CERTIFICATIONS OR AFFIRMATIONS ARE INTENDED.
- THE SYSTEM DETAILED HEREIN IS GENERIC AND DOES NOT PROVIDE INFORMATION FOR A SPECIFIC SITE. FOR SITE CONDITIONS DIFFERENT FROM THE CONDITIONS DETAILED HEREIN, A LICENSED ENGINEER OR REGISTERED ARCHITECT SHALL PREPARE SITE SPECIFIC DOCUMENTS FOR USE IN CONJUNCTION WITH THIS DOCUMENT.
- WATER-TIGHTNESS OF EXISTING HOST SUBSTRATE SHALL BE THE FULL RESPONSIBILITY OF THE INSTALLING CONTRACTOR. CONTRACTOR SHALL ENSURE THAT ANY REMOVED OR ALTERED WATERPROOFING MEMBRANE IS RESTORED AFTER FABRICATION AND INSTALLATION OF STRUCTURE PROPOSED HEREIN. THIS ENGINEER SHALL NOT BE RESPONSIBLE FOR ANY WATERPROOFING OR LEAKAGE ISSUES WHICH MAY OCCUR AS WATER-TIGHTNESS SHALL BE THE FULL RESPONSIBILITY OF THE INSTALLING CONTRACTOR.
- FOR AN EXPLANATION OF EXPOSURE CATEGORIES THAT ACCOMPANY THE Vail WIND SPEEDS USED IN THIS DOCUMENT, SEE SECTION 26.7.3 OF ASCE 7-10.

RHEEM SALES COMPANY, INC.

MECHANICAL UNIT STEEL TIE-DOWN CLIPS

DATE	DRWN	CHKD	DATE
06/14/15	JAC	TSB	

REMARKS
INIT ISSUE

COPYRIGHT FRANK L. BENNARDO P.E.

15-2564

SCALE: N.T.S.
PAGE DESCRIPTION:
35" TALL UNIT
35.75" x 35.75" FOOT PRINT

OF 1
1