

# VA9208-AGx-x Series On/Off and Floating Point Electric Spring Return Valve Actuators

## Installation Instructions

VA9208-AGA-3, VA9208-AGC-3  
VA9208-AGA-2

Part No. 14-1379-5, Rev. A

Issued May 5, 2011

Supersedes April 4, 2011

Refer to the [QuickLIT Web site](#) for the most up-to-date version of this document.

## Applications

The VA9208-AGx-x Series On/Off and Floating Point Electric Spring Return Actuators are direct-mount valve actuators that operate on AC/DC 24 V power. These bidirectional actuators are used to provide accurate positioning on Johnson Controls® VG1000 Series 1-1/4, 1-1/2, and 2 in. (DN32, DN40, and DN50) ball valves in Heating, Ventilating, and Air Conditioning (HVAC) applications.

Integral line voltage auxiliary switches, available only on the VA9208-xxC-3 models, indicate end-stop position, or perform switching functions within the selected rotation range.

VA9208-AGA-2 actuators include plenum-rated cables and are specially configured for installation in spaces used for environmental air-handling purposes other than ducts and plenums as specified in National Fire Protection Association (NFPA) 70: National Electrical Code section 300.22(C), Other Space Used for Environmental Air. The space over a hung ceiling used for environmental air handling purposes is an example of the type of space for which these actuators are configured.

**IMPORTANT:** Use this VA9208 Series Proportional Electric Spring Return Valve Actuator only to control equipment under normal operating conditions. Where failure or malfunction of the VA9208 Series Electric Actuator could lead to personal injury or property damage to the controlled equipment or other property, additional precautions must be designed into the control system. Incorporate and maintain other devices, such as supervisory or alarm systems or safety or limit controls, intended to warn of or protect against failure or malfunction of the VA9208 Series Electric Actuator.

## Installation

Install the ball valve with the actuator at or above the center line of the horizontal piping (see Figure 1).

**IMPORTANT:** In steam applications, install the valve with the stem horizontal to the piping. Failure to follow this precaution may shorten the life of the actuator.

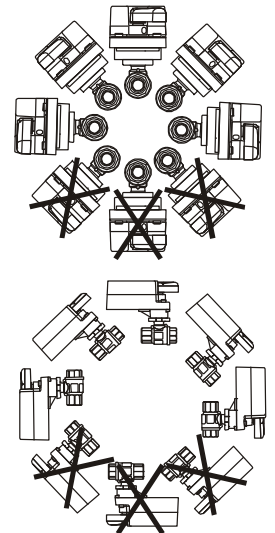

**Figure 1: Mounting Positions for Chilled Water and Condensing Atmosphere Applications**

**IMPORTANT:** Before specifying VA9208 Series Electric Spring Return Valve Actuators for plenum applications, verify acceptance of exposed plastic materials in plenum areas with the local building authority. Building codes for plenum requirements vary by location. Some local building authorities accept compliance to UL 1995, Heating and Cooling Equipment, while others use different acceptance criteria.

**IMPORTANT:** Do not install or use this VA9208 Series Electric Spring Return Valve Actuator in or near environments where corrosive substances or vapors could be present. Exposure of the actuator to corrosive environments may damage the device's internal components, and will void the warranty.

## Special Tools Needed

- Johnson Controls® M9000-200 Commissioning Tool or digital voltmeter
- T-20 TORX® driver

## Dimensions

### Valve Actuator

See Figure 2 and Table 1 for valve actuator dimensions.

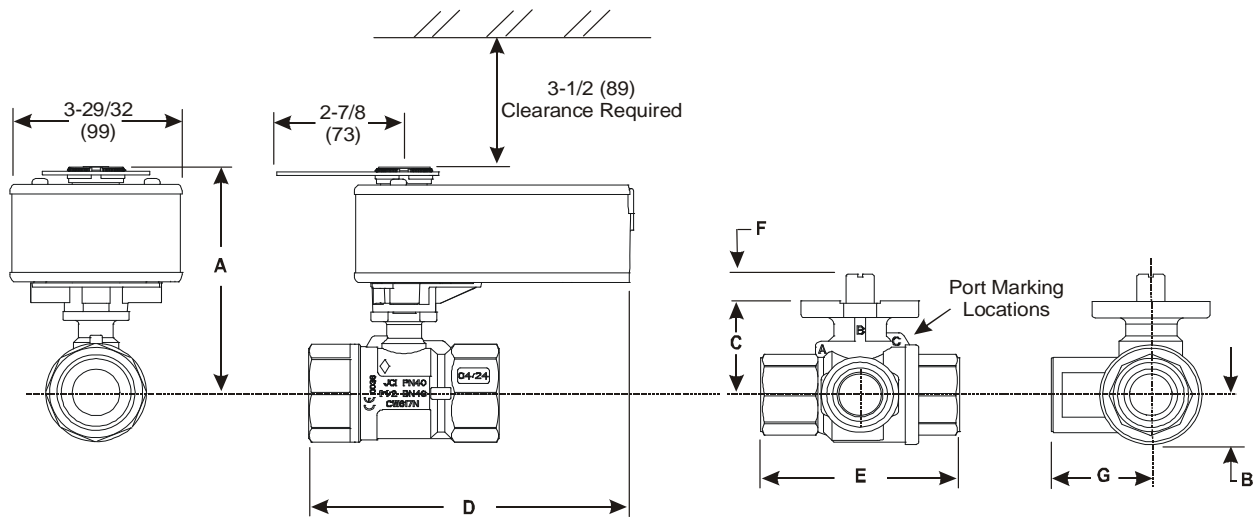

FIG-VA9208X\_dims

**Figure 2: Spring Return VA9208 Actuated VG1241, VG1245, VG1841, and VG1845 Series Ball Valve Dimensions, in. (mm)**

**Table 1: VA9208 Actuated VG1241, VG1245, VG1841, and VG1845 Series Ball Valve Dimensions, in. (mm)**

| Valve Size in. (DN) | Valve Style <sup>1</sup> | A             | B            | C            | D             | E              | F         | G            |
|---------------------|--------------------------|---------------|--------------|--------------|---------------|----------------|-----------|--------------|
| 1-1/4 (DN32)        | All                      | 5-5/32 (131)  | 1-1/32 (26)  | 1-23/32 (44) | 7-1/4 (184)   | 3-15/16 (100)  | 11/32 (9) | 1-31/32 (50) |
| 1-1/2 (DN40)        | All                      | 5-5/16 (135)  | 1-9/64 (29)  | 1-57/64 (48) | 7-7/16 (189)  | 4-21/64 (110)  | 11/32 (9) | 2-11/64 (55) |
| 2 (DN50)            | 2-Way                    | 5-17/32 (140) | 1-15/32 (37) | 2-1/8 (54)   | 7-11/16 (195) | 4-27/320 (132) | 11/32 (9) | 2-27/64 (62) |
|                     | 3-Way                    |               |              |              | 7-7/8 (200)   |                |           |              |

1. Port A must always be connected the coil (Figure 2).

### Valve Actuator with Thermal Barrier

See Figure 3 and Table 2 for valve actuator dimensions with optional M9000-561 Thermal Barrier installed.

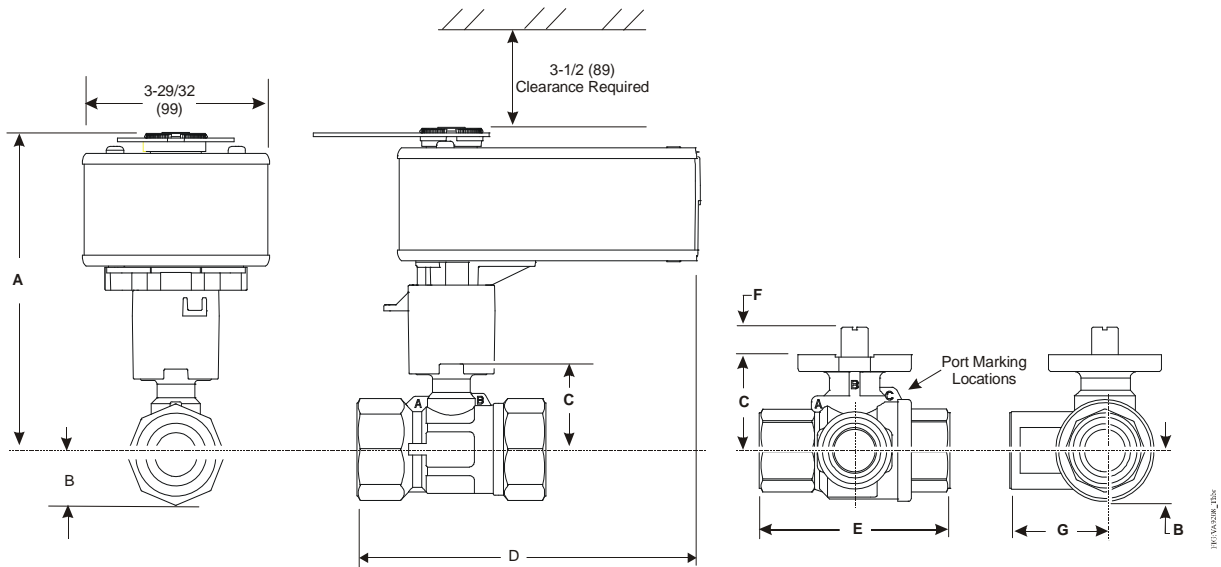

**Figure 3: Spring Return VA9208 Actuated VG1241, VG1245, VG1841, and VG1845 Series Ball Valve with Optional M9000-561 Thermal Barrier Installed Dimensions, in. (mm)**

**Table 2: VA9208 Actuated VG1241, VG1245, VG1841, and VG1845 Series Ball Valve with Optional Thermal Barrier Installed Dimensions, in. (mm)**

| Valve Size in. (DN) | Valve Style <sup>1</sup> | A             | B            | C            | D             | E             | F         | G            |
|---------------------|--------------------------|---------------|--------------|--------------|---------------|---------------|-----------|--------------|
| 1-1/4 (DN32)        | All                      | 9-17/64 (235) | 1-1/32 (26)  | 1-23/32 (44) | 7-1/4 (184)   | 3-15/16 (100) | 11/32 (9) | 1-31/32 (50) |
| 1-1/2 (DN40)        | All                      | 9-15/16 (240) | 1-9/64 (29)  | 1-57/64 (48) | 7-7/16 (189)  | 4-21/64 (110) | 11/32 (9) | 2-11/64 (55) |
| 2 (DN50)            | 2-Way                    | 9-31/32 (244) | 1-15/32 (37) | 2-1/8 (54)   | 7-11/16 (195) | 4-27/32 (123) | 11/32 (9) | N/A          |
|                     | 3-Way                    |               |              |              | 7-7/8 (200)   |               |           | 2-27/64 (62) |

1. Port A must always be connected the coil (Figure 3).

## Accessories

**Table 3: Accessories (Order Separately)**

| Code Number      | Description  |
|------------------|--|
| <b>M9000-200</b> | Commissioning Tool that Provides a Control Signal to Drive 24 V On/Off, Floating, Proportional, and/or Resistive Electric Actuators                        |
| <b>M9000-560</b> | Ball Valve Linkage Kit for applying M9203 and M9208 Series Actuators to VG1000 Series Valves (Quantity 1)  |
| <b>M9000-561</b> | Thermal Barrier Extends M(VA)9104, M(VA)9203, and M(VA)9208 Series Electric Spring Return Actuator Applications to Include Low Pressure Steam (Quantity 1) |
| <b>M9000-341</b> | Weathershield Kit for VG1000 Series Ball Valve application of M(VA)9104, M(VA)9203, and M(VA)9208 Series Electric Spring Return Actuators (Quantity 1)     |
| <b>M9208-604</b> | Replacement Manual Override Cranks with Long Crank Radius: 2.83 in. (72 mm) (Quantity 5)   |
| <b>M9208-605</b> | Replacement Manual Override Cranks with Short Crank Radius: 1.83 in. (46.5 mm) (Quantity 5)  |

## Mounting

### Mounting the Actuator to Spring Return Port A (Coil) Open

To mount the actuator to Spring Return Port A (Coil) open:

1. Turn the valve stem to the position outlined in Figure 4.

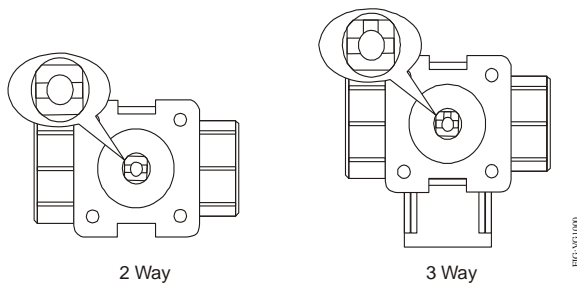
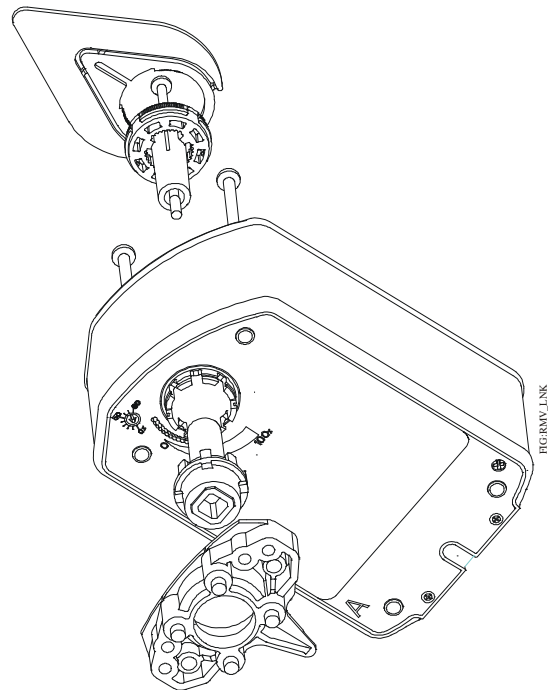

**Figure 4: Positioning the Valve Stem**

2. Mount optional M9000-561 Thermal Barrier to the valve if fluid temperature exceeds 212°F (100°C). See the [Mounting the Thermal Barrier](#) section for more information.

**Note:** Proceed to Step 7 if the ball valve linkage is on actuator Side B.

3. Remove the linkage from Side A (Figure 5).



**Figure 5: Removing the Linkage**

4. Insert the drive shaft into Side B (Figure 6).

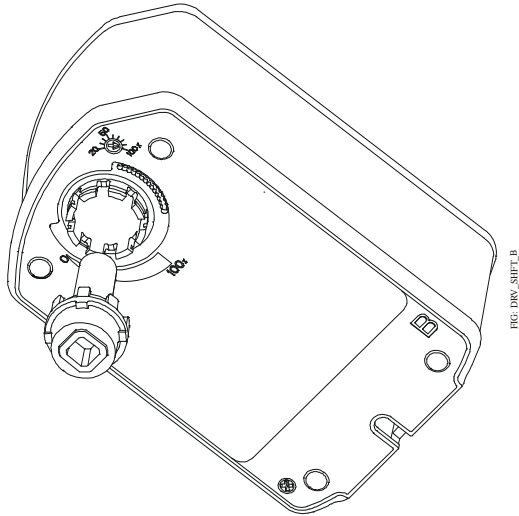

**Figure 6: Inserting the Drive Shaft**

5. Install linkage base on Side B using the two #10-14 x 2.75 in. long screws (Figure 7). The recommended torque is 20 to 24 lb-in. (2.3 to 2.7 N·m).

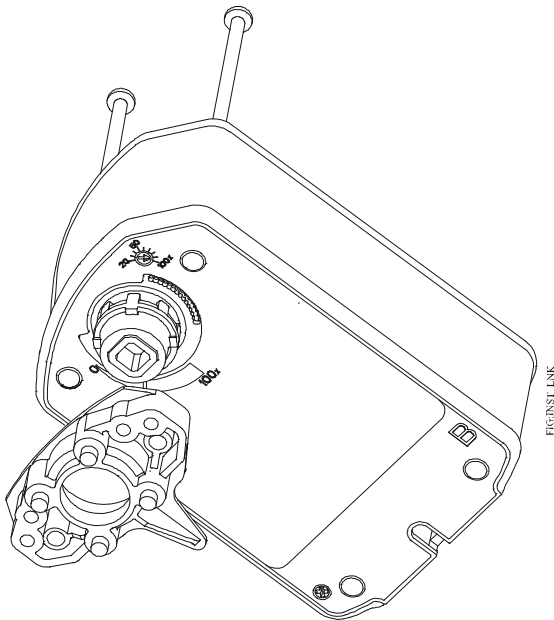

**Figure 7: Installing the Linkage**

6. Insert fixed pointer and M4x0.7x83 mm long screw into the Side A actuator hub. Direct the arrow on the pointer to 100%.

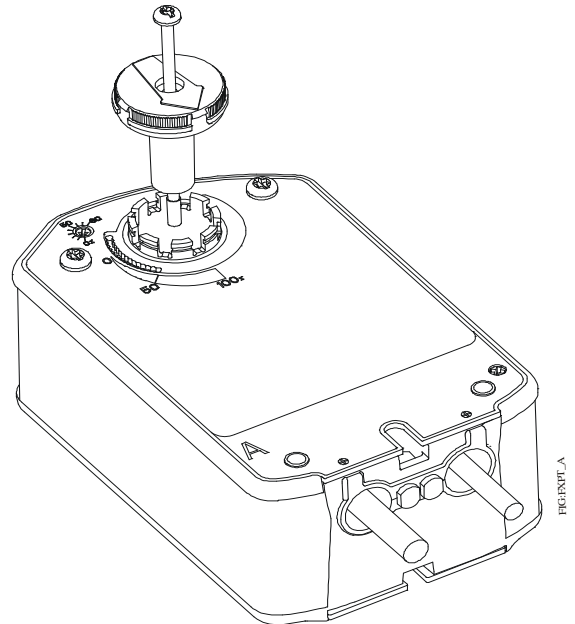

**Figure 8: Installing the Fixed Pointer**

7. Install the actuator on the ball valve (Figure 9). Tighten the actuator mounting screw to a torque of 10 to 12 lb-in. (1.1 to 1.4 N·m) and snap in the large adjustable pointer into place.

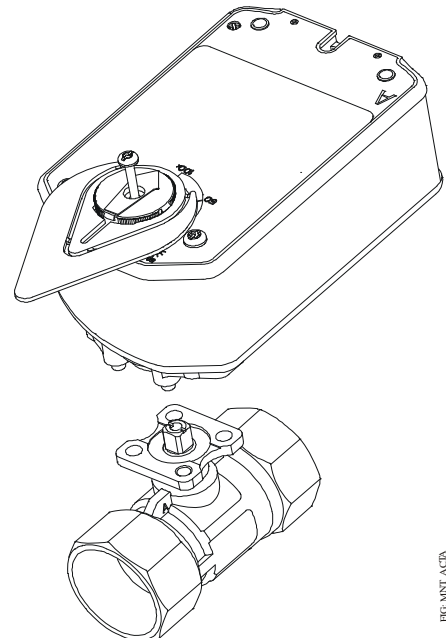
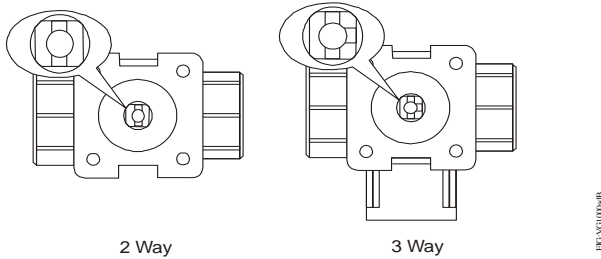

**Figure 9: Mount the Actuator**

## Mounting the Actuator to Spring Return Port A (Coil) Closed

To mount the actuator to spring return port A (coil) closed:

1. Turn the valve stem to the position outlined in Figure 10.

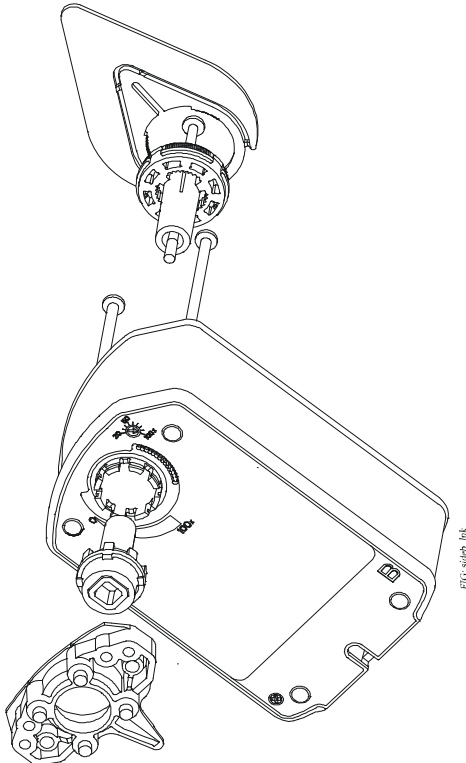

**Figure 10: Positioning the Valve Stem**

2. Mount optional M9000-561 Thermal Barrier to the valve if fluid temperature exceeds 212°F (100°C). See the [Mounting the Thermal Barrier](#) section for more information.

**Note:** Proceed to Step 7 if the ball valve linkage is on actuator Side A.

3. Remove the linkage from Side B (Figure 11).



**Figure 11: Removing the Linkage**

4. Insert the drive shaft into Side A (Figure 12).

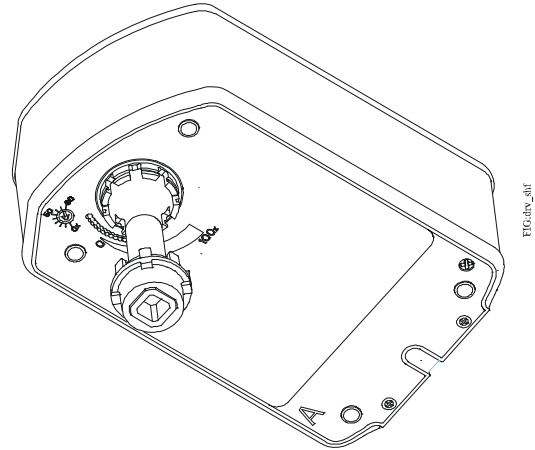

**Figure 12: Inserting the Drive Shaft**

5. Install linkage base on Side A using the two #10 14 x 2.75 in. long screws. The recommended torque is 20 to 24 lb-in. (2.3 to 2.7 N·m).

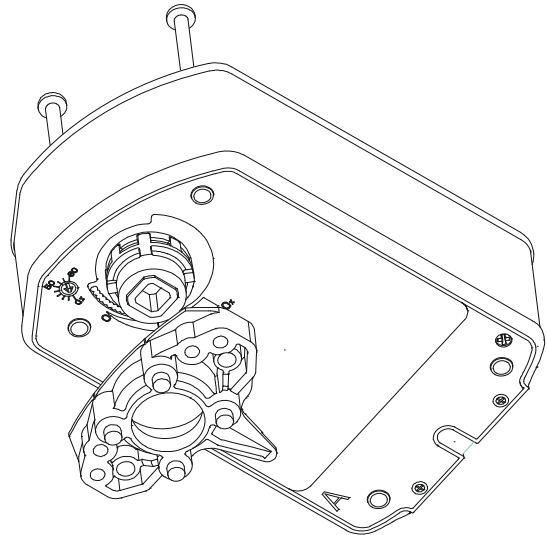

**Figure 13: Installing the Linkage**

6. Insert fixed pointer and M4x0.7x83 mm long screw into the Side B actuator hub. Direct the arrow on the pointer to 0% (Figure 14).

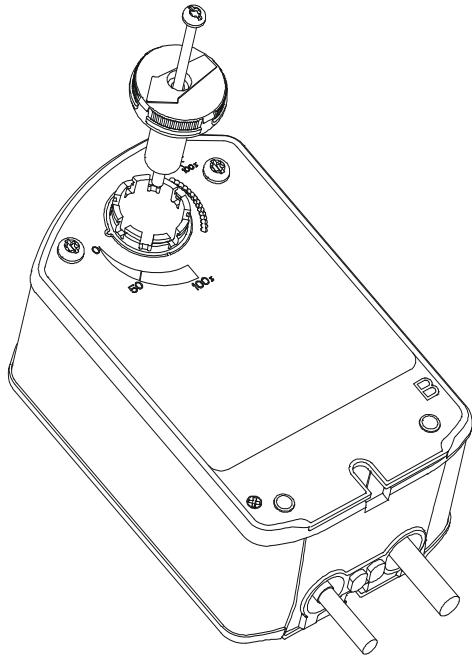

**Figure 14: Installing the Fixed Pointer**

7. Install the actuator on the ball valve (Figure 15). Tighten the actuator mounting screw to a torque of 10 to 12 lb·in. (1.1 to 1.4 N·m) and snap the large adjustable pointer into place.

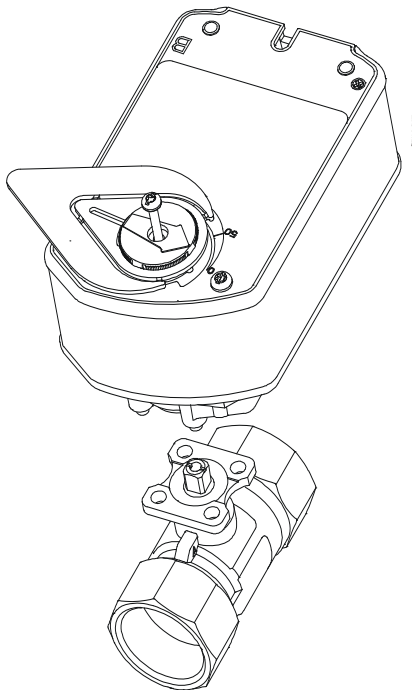

**Figure 15: Mount the Actuator**

### **Mounting the Thermal Barrier**

Figure 16 shows the optional M9000-561 Thermal Barrier.

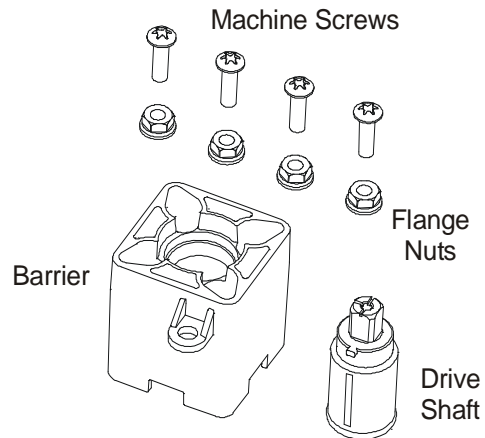

**Figure 16: Optional M9000-561 Thermal Barrier**

To mount the optional thermal barrier:

1. Install the thermal barrier drive shaft into the thermal barrier by aligning the tab on the drive shaft with the slot on the thermal barrier (Figure 17).

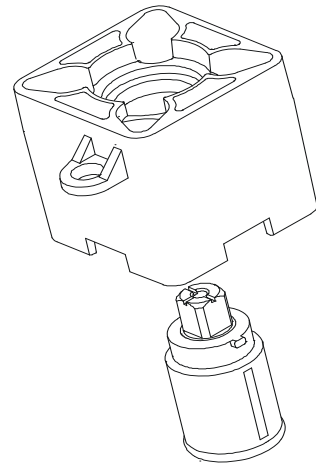

**Figure 17: Installing the Drive Shaft into the Thermal Barrier**

2. Rotate the drive shaft to align marks on the top of the thermal drive shaft with matching marks on the valve stem.

3. Mount the thermal barrier onto the valve using the four included M5x16 mm machine screws and four M5 flange nuts. Tighten the screws to a recommended torque of 21 to 25 lb-in. (2.4 to 2.8 N-m) (Figure 18)

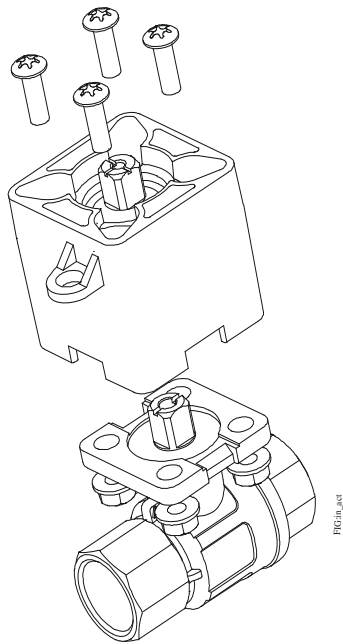

**Figure 18: Installing the Barrier**

4. Proceed to the actuator mounting instructions. Follow the same steps as mounting directly to the valve when mounting actuator to the thermal barrier.

**Note:** Depending on your application, you may position the assembly in any of the four 90° increments on the valve.

### **Manual Override**

Use only the supplied manual override crank to reposition the actuator hub when using the manual override feature.

**IMPORTANT:** Applying excessive torque to the manual override or operating the manual override with a power tool may damage the internal components of the actuator and cause premature failure.

To reposition the actuator hub, proceed as follows:

1. De-energize the actuator.
2. Insert the hex end of the manual override crank into the manual override adjustment point on the face of the actuator.

3. Rotate the manual override crank in the direction indicated by the arrow on the label.
4. The actuator requires 8-1/2 manual override crank rotations from the full spring return position to fully reposition the actuator hub. At the end of travel, the rotation resistance increases. Do not force the manual crank past this point.
5. While holding the manual crank in the wound position, rotate and hold the red lock shaft approximately 10° then release the manual crank to lock the actuator hub in place.

**Note:** Insert and slightly rotate the manual crank in the direction indicated by the arrow on the label to unlock the actuator hub. Alternately, the actuator hub automatically unlocks when power is applied to the actuator, and returns the actuator to normal drive and spring return operation.

### **Wiring**



**WARNING: Risk of Electric Shock.**

Disconnect or isolate all power supplies before making electrical connections. More than one disconnect or isolation may be required to completely de-energize equipment. Contact with components carrying hazardous voltage can cause electric shock and may result in severe personal injury or death.



**CAUTION: Risk of Property Damage.**

Do not apply power to the system before checking all wiring connections. Short circuited or improperly connected wires may result in permanent damage to the equipment.



**CAUTION: Risk of Property Damage.**

Insulate and secure each unused wire lead before applying power to the actuator. Failure to insulate and secure each unused wire lead may result in property damage.

**IMPORTANT:** Make all wiring connections in accordance with the National Electrical Code and local regulations. Use proper Electrostatic Discharge (ESD) precautions during installation and servicing to avoid damaging the electronic circuits of the actuator.

See Figure 19 to wire the applicable VA9208-AGx-x Series model.



Floating Control, Four Wire

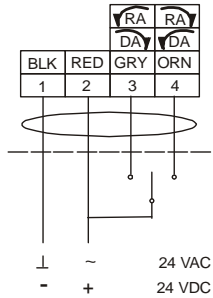

Open/Close, Single Wire Control

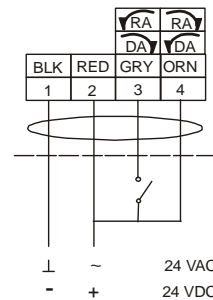

On/Off Control, Two Wire

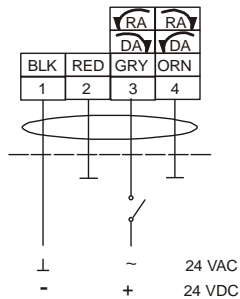

Floating Control, Multiple Actuators with One Transformer

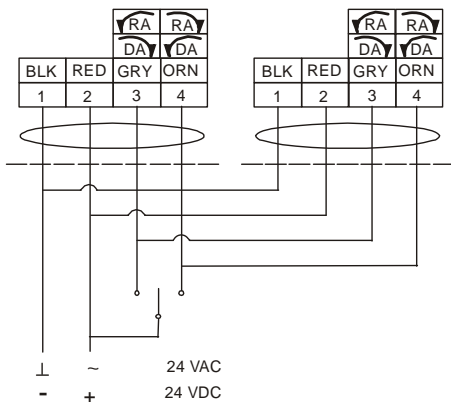

Figure 19: Control Wiring Diagrams

**IMPORTANT:** Multiple VA9208-AGx-x Actuators must be on independent loads.

Figure 20 shows the optional Auxiliary Switch Wiring.

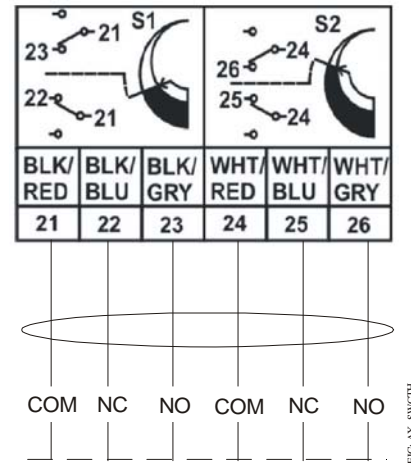

Figure 20: Optional Auxiliary Switch Wiring

### Using Conduit

All VA9208 Series Actuators accept 3/8 in. (10 mm) trade size flexible metal conduit.

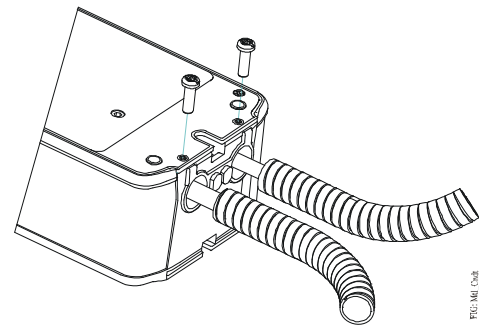

Figure 21: Adding Flexible Metal Conduit

1. Feed the actuator cables through the field-supplied conduit.
2. Push the conduit into the holes in the actuator and secure it with the supplied 10-32 x 9/16 in. screws, as illustrated in Figure 21. The product label marks the position of holes for the screws. Drive the screws through the product label in the marked positions. Drive the screwhead flush with the plate to secure the conduit.

**IMPORTANT:** Careful workmanship is required to secure flexible metal conduit. Cut the conduit end perpendicular to its axis. Insert the cut end into the bottom of the holes in the actuator and hold the conduit in place while securing it with the screws provided. Check a completed installation by pulling on the conduit to ensure its retention.

## Setup and Adjustments

### Mode Selection Switch

Actuators have an external mode selection switch to reverse control logic. The switch is accessible from both A and B sides of the actuator as illustrated in Figure 22. Actuators are delivered in Direct Acting (DA) mode and can be switched by the user to Reverse Acting (RA) mode.

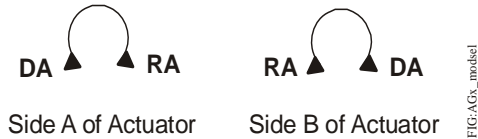

Figure 22: Mode Selection

### Control Response

The installation side of the actuator and the position of the mode selection switch combine to determine control response from the actuator. See Figure 23.

| Control Inputs |          | Mode Selection Switch |      |      |      |
|----------------|----------|-----------------------|------|------|------|
| GRY<br>3       | ORN<br>4 | A                     |      | B    |      |
|                |          | DA                    | RA   | RA   | DA   |
| CLOSED         | OPEN     | ↘                     | ↙    | ↘    | ↙    |
| OPEN           | CLOSED   | ↙                     | ↘    | ↙    | ↘    |
| OPEN           | OPEN     | STOP                  | STOP | STOP | STOP |
| CLOSED         | CLOSED   | ↘                     | ↙    | ↘    | ↙    |

FIG:VA9208-xxC-3DRspns

Figure 23: Control Response

### Auxiliary Switch (VA9208-xxC-3 Models)

The VA9208-xxC-3 models include two integral auxiliary switches with a switch adjuster accessible on either face of the actuator (Figure 5). The factory setting for Auxiliary Switch No. 1 is 83% closing, and the nominal setting for Auxiliary Switch No. 2 is 10% opening (relative to the 0 to 100% rotation range as printed on the product label). See the [Technical Specifications](#) table for the auxiliary switch ratings.



### WARNING: Risk of Electric Shock and Property Damage.

Insulate and secure each unused wire lead before applying power to the actuator. Failure to insulate and secure each unused wire lead may result in property damage, electric shock, and severe personal injury or death.

The switch point of Auxiliary Switch No. 1 is fixed. The switch point of Auxiliary Switch No. 2 is independently and continuously adjustable from 74 to 5% position. For the most accurate switch positioning, see Figure 24 and use the method in the following example. To change the switch point of Auxiliary Switch No. 2, proceed as follows:

1. Position the actuator in the full spring return position.

**Note:** The switch is factory set to trip when the actuator reaches the 10% position.

2. Rotate the switch adjuster until it points to the desired switch point.

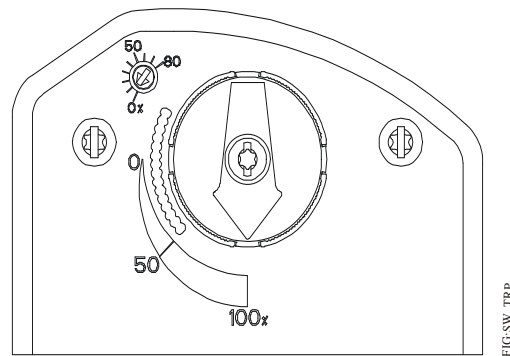

Figure 24: Switch Trip Point Settings

3. Connect Auxiliary Switch No. 2 to a power source or an ohmmeter and apply power to the actuator. The actuator moves to the fully open position and holds while power is applied.
4. Observe the switch point. If required, repeat Step 1 through Step 3.

### Repair Information

A number of replacement parts are available; see Table 3 for more details. If a VA9208 Series Electric Spring Return Actuator fails to operate within its specifications, replace the unit. For a replacement electric actuator, contact the nearest Johnson Controls representative.

## Technical Specifications

### VA9208-AGx-x Series On/Off and Floating Point Electric Spring Return Actuators (Part 1 of 2)

|   |  |  |
|---|--|--|
| <b>Power Requirements</b>                     | <b>-AGx Models</b>   | AC 24 V (AC 19.2 V to 28.8 V) at 50/60 Hz: Class 2 (North America) or Safety Extra-Low Voltage (SELV) (Europe), 7.9 VA Running, 5.5 VA Holding Position<br>DC 24 V (DC 21.6 V to 28.8 V): Class 2 (North America) or SELV (Europe)<br>3.5 W Running, 1.9 W Holding Position<br>Minimum Transformer Size: 8 VA per Actuator |
| <b>Input Signal/ Adjustments</b>              | <b>-AGx Models</b>   | AC 19.2 to 28.8 V at 50/60 Hz or DC 24 V +20%/-10% Class 2 (North America) or SELV (Europe) Minimum Pulse Width: 500 ms  |
| <b>Control Input Impedance</b>                | <b>-AGx Models</b>   | 3,000 ohm Control Inputs   |
| <b>Auxiliary Switch Rating</b>                | <b>-xxC Models</b>   | Two Single-Pole, Double-Throw (SPDT), Double-Insulated Switches with Gold over Silver Contacts:<br>AC 24 V, 50 VA Pilot Duty<br>AC 120 V, 5.8 A Resistive, 1/4 hp, 275 VA Pilot Duty<br>AC 240 V, 5.0 A Resistive, 1/4 hp, 275 VA Pilot Duty   |
| <b>Spring Return</b>                          |  | Direction is Selectable with Mounting Position of Actuator:<br>Actuator Face Labeled A is Away from Valve: CCW Spring Return<br>Actuator Face Labeled B is Away from Valve: CW Spring Return   |
| <b>Rated Torque</b>                           | <b>Power On (Running)</b>  | 70 lb-in. (8 N-m) All Operating Temperatures   |
|   | <b>Power Off (Spring Returning)</b>                                      | 70 lb-in. (8 N-m) All Operating Temperatures   |
| <b>Rotation Range</b>                         |  | Maximum Full Stroke: 95°   |
| <b>Rotation Time for 90 Degrees of Travel</b> | <b>Power On (Running)</b>  | 150 Seconds for 0 to 70 lb-in. (8 N-m) Load, at all Operating Conditions   |
|   | <b>Power Off (Spring Returning)</b>                                      | 17 to 25 Seconds for 0 to 70 lb-in. (8 N-m) Load, at Room Temperature<br>22 Seconds Nominal at Full Rated Load<br>94 Seconds Maximum with 70 lb-in. (8 N-m) Load, at -40°F (-40°C)   |
| <b>Life Cycles</b>                            |  | 60,000 Full Stroke Cycles with 70 lb-in. (8 N-m) Load<br>1,500,000 Repositions with 70 lb-in. (8 N-m) Load   |
| <b>Audible Noise Rating</b>                   | <b>Power On (Running)</b>  | <35 dBA at 70 lb-in. (8 N-m) Load, at a Distance of 39-13/32 in. (1 m)   |
|   | <b>Power On (Holding)</b>  | <20 dBA at a Distance of 39-13/32 in. (1 m)  |
|   | <b>Power Off (Spring Returning)</b>                                      | <52 dBA at 70 lb-in. (8 N-m) Load, at a Distance of 39-13/32 in. (1 m)   |
| <b>Electrical Connections</b>                 | <b>AGx-3 Models</b>  | 48 in. (1.2 m) UL 758 Type AWM Halogen Free Cable with 18 AWG (0.85 mm <sup>2</sup> ) Conductors and 1/4 in. (6 mm) Ferrule Ends   |
|   | <b>AGx-2 Models</b>  | 120 in. (3.05 m) UL 444 Type CMP Plenum Rated Cable with 19 AWG (0.75 mm <sup>2</sup> ) Conductors and 1/4 in. (6 mm) Ferrule Ends   |
|   | <b>Auxiliary Switches (-xxC Models)</b>                                  | 48 in. (1.2 m) UL 758 Type AWM Halogen Free Cable with 18 AWG (0.85 mm <sup>2</sup> ) Conductors and 1/4 in. (6 mm) Ferrule Ends   |
| <b>Conduit Connections</b>                    |  | Integral Connectors for 3/8 in. (10 mm) Flexible Metal Conduit   |
| <b>Fluid Temperature Limits</b>               | <b>VG12x1 and VG18x1 Series</b>  | 23 to 203°F (-5 to 95°C), Not Rated for Steam Service  |
|   | <b>VG12x5 and VG18x5 Series</b>  | -22 to 212°F (-30 to 100°C), Not Rated for Steam Service   |
|   | <b>VG12x5 and VG18x5 Series with M9000-561 Thermal Barrier Installed</b> | -22 to 284°F (-30 to 140°C) water; 15 psig (103 kPa) at 250°F (121°C) Saturated Steam  |

**VA9208-AGx-x Series On/Off and Floating Point Electric Spring Return Actuators (Part 2 of 2)**

|                                    |                                  |   |
|------------------------------------|----------------------------------|---|
| <b>Ambient Conditions</b>          | <b>Standard Operating</b>        | -40 to 140°F (-40 to 60°C); 90% RH Maximum, Noncondensing   |
|                                    | <b>Storage</b>                   | -40 to 185°F (-40 to 85°C); 95% RH Maximum, Noncondensing   |
| <b>Enclosure Rating</b>            |                                  | NEMA 2 (IP54) for all Mounting Directions   |
| <b>Compliance</b><br><br><b>CE</b> | <b>United States</b>             | UL Listed, CCN XAPX, File E27734; to UL 60730-1A: 2003-08, Ed. 3.1, Automatic Electrical Controls for Household and Similar Use; and UL 60730-2-14: 2002-02, Ed. 1, Part 2 Particular Requirements for Electric Actuators |
|                                    | <b>Canada</b>                    | UL Listed, CCN XAPX7, File E27734; to UL 60730-1:02-CAN/CSA: July 2002, 3rd Ed., Automatic Electrical Controls for Household and Similar Use; and CSA C22.2 No. 24-93 Temperature Indicating and Regulating Equipment     |
|                                    | <b>Europe</b>                    | CE Mark – Johnson Controls, Inc., declares that this product is in compliance with the essential requirements and other relevant provisions of the EMC Directive 2004/108/EC and the Low Voltage Directive 2006/95/EC.    |
|                                    | <b>Australia and New Zealand</b> | C-Tick Mark, Australia/NZ Emissions Compliant   |
| <b>Shipping Weight</b>             | <b>-AGA Models</b>               | 3.5 lb (1.6 kg)   |
|                                    | <b>-AGC Models</b>               | 3.9 lb (1.8 kg)   |



**Building Efficiency**

507 E. Michigan Street, Milwaukee, WI 53202

*Metasys® and Johnson Controls® are registered trademarks of Johnson Controls, Inc. All other marks herein are the marks of their respective owners. © 2011 Johnson Controls, Inc.*