

# VA9203-GGx-xx Series Proportional Electric Spring Return Valve Actuators

## Installation Instructions

VA9203-GGA-2Z, VA9203-GGB-2Z

Part No. 14-1380-24, Rev. A

Issued August 1, 2013

Supersedes April 22, 2011

Refer to the [QuickLIT website](#) for the most up-to-date version of this document.

### Applications

The VA9203-GGx-2Z Series Proportional Electric Spring Return Actuators are direct-mount valve actuators that operate on AC/DC 24 V power. These bidirectional actuators are used to provide accurate positioning on Johnson Controls® VG1000 Series 1/2, 3/4, and 1 in. (DN15, DN20, and DN25) ball valves in Heating, Ventilating, and Air Conditioning (HVAC) applications.

An integral line voltage auxiliary switch, available only on the VA9203-GGB-2Z model, indicates end-stop position, or performs switching functions within the selected rotation range.

VA9203-GGA-2Z actuators include plenum-rated cables and are specially configured for installation in spaces used for environmental air-handling purposes other than ducts and plenums as specified in National Fire Protection Association (NFPA) 70: National Electrical Code section 300.22(C), Other Space Used for Environmental Air. The space over a hung ceiling used for environmental air handling purposes is an example of the type of space for which these actuators are configured.

**IMPORTANT:** Use this VA9203 Series Valve Actuator only to control equipment under normal operating conditions. Where failure or malfunction of the VA9203 Series Valve Actuator could lead to personal injury or property damage to the controlled equipment or other property, additional precautions must be designed into the control system. Incorporate and maintain other devices, such as supervisory or alarm systems or safety or limit controls, intended to warn of or protect against failure or malfunction of the VA9203 Series Electric Actuator.

### Installation

Install the ball valve with the actuator at or above the center line of the horizontal piping (see Figure 1).

**IMPORTANT:** In steam applications, install the valve with the stem horizontal to the piping. Failure to follow this precaution may shorten the life of the actuator.

**IMPORTANT:** Do not install or use this actuator in or near environments where corrosive substances or vapors could be present. Exposure of the actuator to corrosive environments may damage the device's internal components, and will void the warranty.

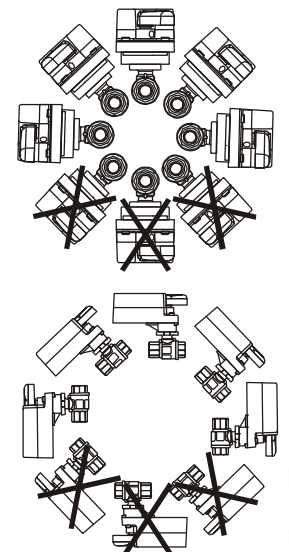

**Figure 1: Mounting Positions for Chilled Water and Condensing Atmosphere Applications**

### Special Tools Needed

- Johnson Controls® M9000-200 Commissioning Tool or digital voltmeter
- T-20 TORX® driver

## Dimensions

### Valve Actuator

See Figure 2 and Table 1 and Table 2 for dimensions of Spring Return VA9203 Series Actuated Ball Valves.

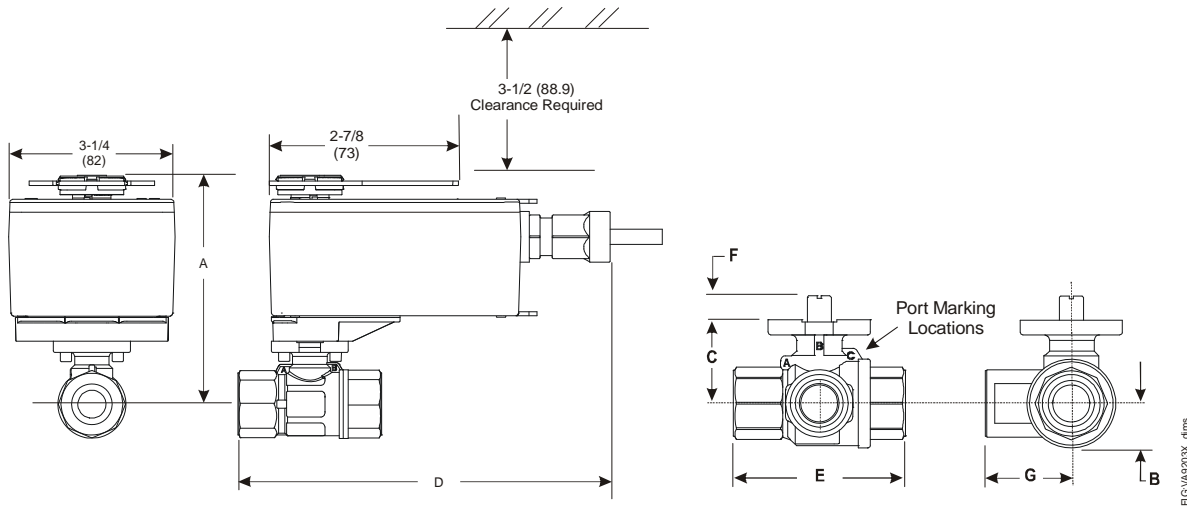

**Figure 2: Spring Return VA9203 Actuated VG1241, VG1245, VG1841, and VG1845 Series Ball Valve Dimensions, in. (mm)**

**Table 1: VA9203 Actuated VG1241, VG1245, VG1841, and VG1845 Series NPT Ball Valve Dimensions, in. (mm)**

Valve Size, in. (DN) <sup>1</sup>	A	B	C	D	E	F	G
1/2 (DN15)	4-5/8 (117.3)	21/32 (17)	1-7/32 (31)	6-31/32 (177)	2-33/64 (64)	11/32 (9)	1-1/4 (32)
3/4 (DN20)	4-5/8 (117.3)	21/32 (17)	1-7/32 (31)	7-1/8 (181)	2-51/64 (71)	11/32 (9)	1-13/32 (36)
1 (DN25)	4-11/16 (119)	3/4 (19)	1-19/64 (33)	7-31/64 (190)	3-13/32 (87)	11/32 (9)	1-45/64 (43)

1. Port A must always be connected to the coil.

**Table 2: VA9203 Actuated VG1271, VG1275, VG1871, and VG1875 Series Sweat Ball Valve and VA9203 Actuated VG1291, VG1295, VG1891, and VG1895 Series Press Ball Valve Dimensions, in. (mm)**

Valve Size, in. (DN) <sup>1</sup>	A	B	C	D	E	F	G
1/2 (DN15)	4-5/8 (117.3)	21/32 (17)	1-7/32 (31)	7-13/64 (183)	3-25/32 (96)	11/32 (9)	1-1/4 (32)
3/4 (DN20)	4-5/8 (117.3)	21/32 (17)	1-7/32 (31)	7-3/4 (197)	4-3/32 (104)	11/32 (9)	1-13/32 (36)
1 (DN25)	4-11/16 (119)	3/4 (19)	1-19/64 (33)	8-3/16 (208)	4-41/64 (118)	11/32 (9)	1-45/64 (43)

1. Port A must always be connected to the coil.

## Valve Actuator with Thermal Barrier

See Figure 3 and Table 3 for valve actuator dimensions with optional M9000-561 thermal barrier installed.

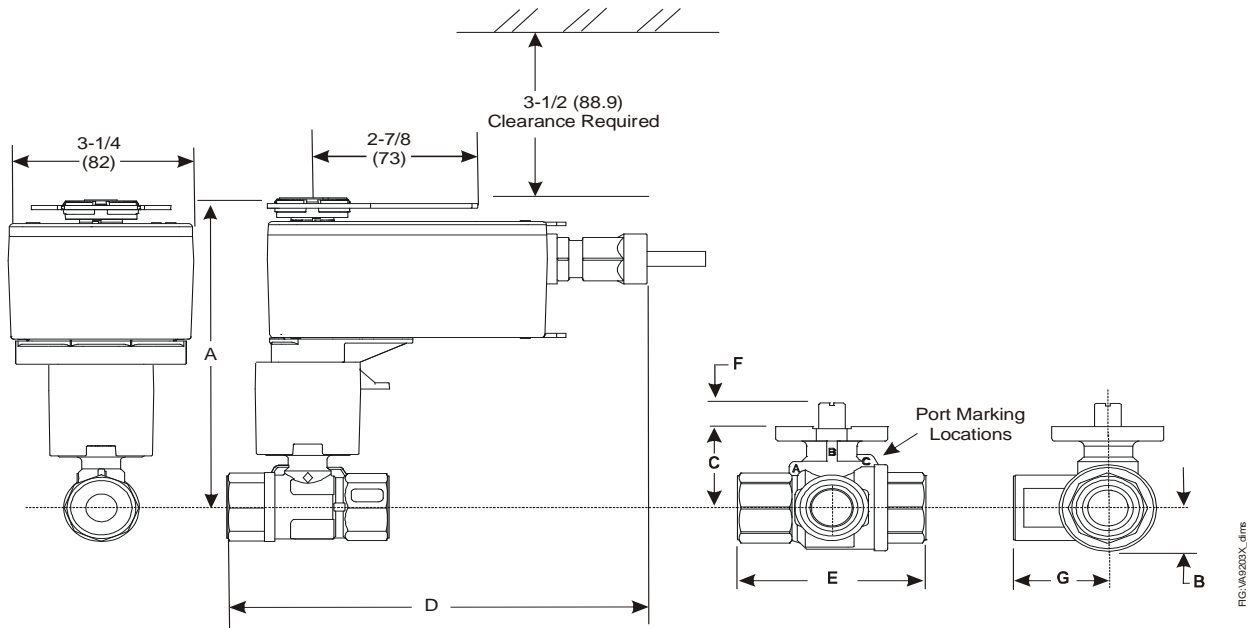

**Figure 3: Spring Return VA9203 Actuated VG1241, VG1245, VG1841, and VG1845 Series Ball Valve with Optional M9000-561 Thermal Barrier Installed Dimensions, in. (mm)**

**Table 3: VA9203 Actuated VG1241, VG1245, VG1841, and VG1845 Series NPT Ball Valve with Optional Thermal Barrier Installed Dimensions, in. (mm)**

Valve Size in. (DN) <sup>1</sup>	A	B	C	D	E	F	G
1/2 (DN15)	6 (152)	21/32 (17)	1-7/32 (31)	6-31/32 (177)	2-33/64 (64)	11/32 (9)	1-1/4 (32)
3/4 (DN20)	6 (152)	21/32 (17)	1-7/32 (31)	7-1/8 (181)	2-51/64 (71)	11/32 (9)	1-13/32 (36)
1 (DN25)	6-1/16 (154)	3/4 (19)	1-19/64 (33)	7-31/64 (190)	3-13/32 (87)	11/32 (9)	1-45/64 (43)

1. Port A must always be connected to the coil.

## Accessories

**Table 4: Accessories (Order Separately)**

Code Number	Description
<b>M9000-200</b>	Commissioning Tool that Provides a Control Signal to Drive 24 V On/Off, Floating, Proportional, and/or Resistive Electric Actuators
<b>M9000-560</b>	Ball Valve Linkage Kit for Applying M9203 and M9208 Series Actuators to VG1000 Series Valves (quantity 1)
<b>M9000-561</b>	Thermal Barrier Extends M(VA)9104, M(VA)9203, and M(VA)9208 Series Electric Spring Return Actuator Applications to Include Low Pressure Steam (quantity 1)
<b>M9000-341</b>	Weathershield Kit for VG1000 Series Ball Valve Application of M(VA)9104, M(VA)9203, and M(VA)9208 Series Electric Spring Return Actuators (quantity 1)
<b>M9000-607</b>	Position Indicator for VG1000 Series Ball Valve Applications (quantity 5)

## Mounting

### Mounting the Actuator to Spring Return Port A (Coil) Open

To mount the actuator to Spring Return Port A (Coil) Open:

1. Turn the valve stem to the position outlined in Figure 4.

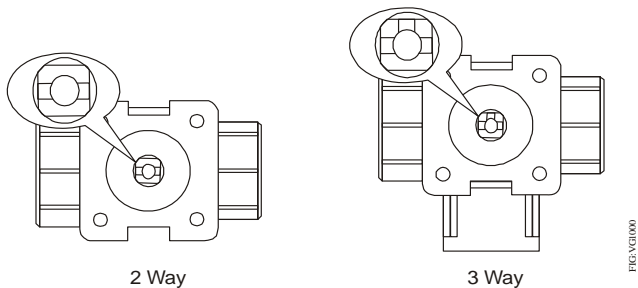
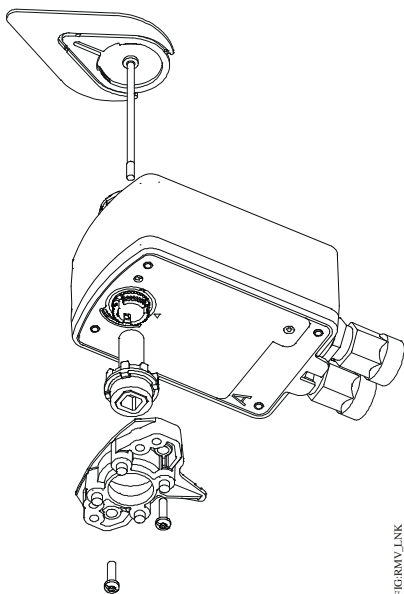

**Figure 4: Positioning the Valve Stem**

2. Mount optional M9000-561 Thermal Barrier to the valve if fluid temperature exceeds 212°F (100°C). See the [Mounting the Thermal Barrier](#) section for more information.

**Note:** Proceed to Step 7 if the ball valve linkage is on actuator Side B.

3. Remove the linkage from Side A (Figure 5).



**Figure 5: Removing the Linkage**

4. Insert the drive shaft into Side B (Figure 6). The drive shaft is keyed for one-way assembly. With gentle pressure applied, rotate the drive shaft until the key aligns and the drive shaft falls into place.

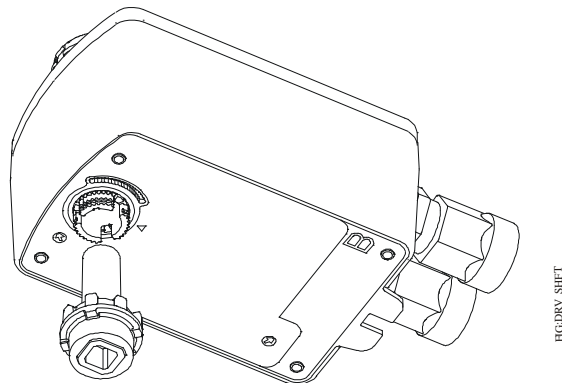

**Figure 6: Inserting the Drive Shaft**

5. Install linkage base on Side B using the two #8-32 x 0.625 in. long screws (Figure 7). The recommended torque is 29 to 33 lb-in. (3.3 to 3.7 N·m).

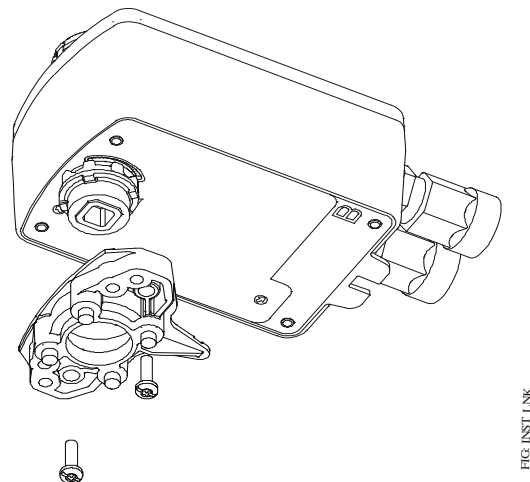

**Figure 7: Installing the Linkage**

6. Insert fixed pointer and M4x0.7x83 mm long screw into the Side A actuator hub (Figure 8). Direct the arrow on the pointer to 100%.

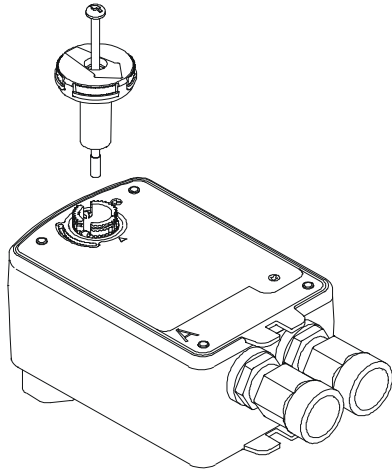

**Figure 8: Installing the Fixed Pointer**

7. Install the actuator on the ball valve (Figure 9). Tighten the actuator mounting screw to a torque of 10 to 12 lb·in. (1.1 to 1.4 N·m) and snap the large adjustable pointer into place.

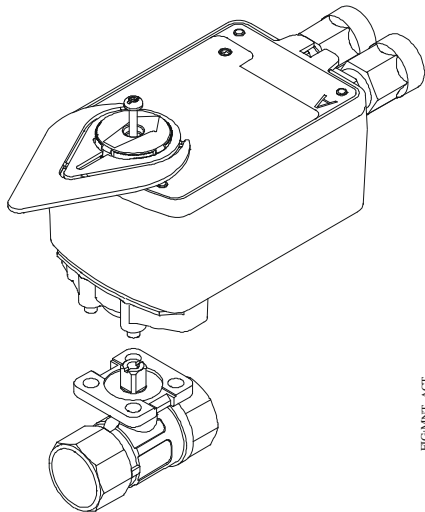
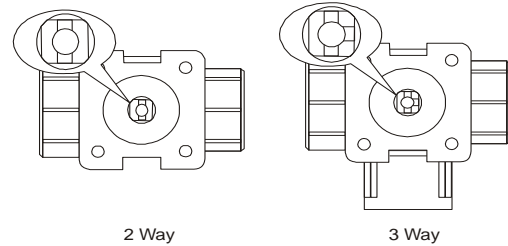

**Figure 9: Mount the Actuator**

### **Mounting the Actuator to Spring Return Port A (Coil) Closed**

To mount the actuator to spring return port A (coil) closed:

1. Turn the valve stem to the position outlined in Figure 10.

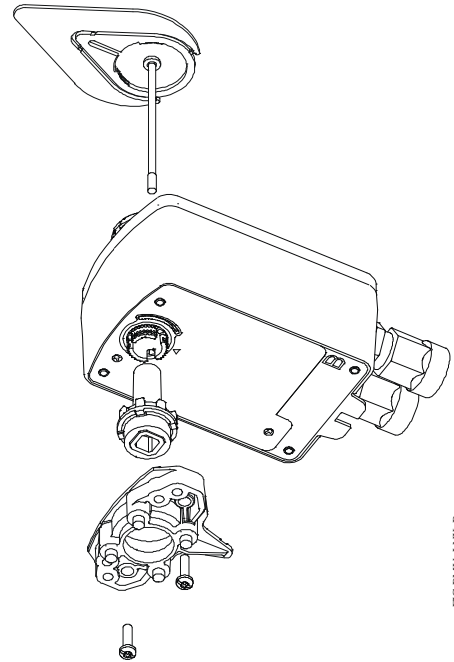

**Figure 10: Positioning the Valve Stem**

2. Mount optional M9000-561 Thermal Barrier to the valve if fluid temperature exceeds 212°F (100°C). See the *Mounting the Thermal Barrier* section for more information.

**Note:** Proceed to Step 7 if the ball valve linkage is on actuator Side A.

3. Remove the linkage from Side B (Figure 13).



**Figure 11: Removing the Linkage**

4. Insert the drive shaft into Side A (Figure 12). The drive shaft is keyed for one-way assembly. With gentle pressure applied, rotate the drive shaft until the key aligns and the drive shaft falls into place.

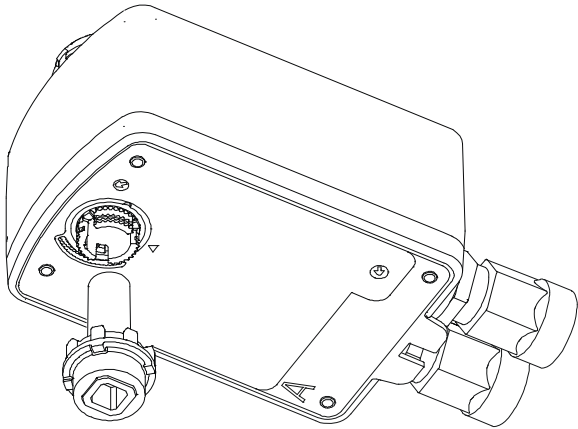

**Figure 12: Inserting the Drive Shaft**

5. Install linkage base on Side A using the two #8-32 x 0.625 in. long screws (Figure 13). The recommended torque is 29 to 33 lb-in. (3.3 to 3.7 N-m).

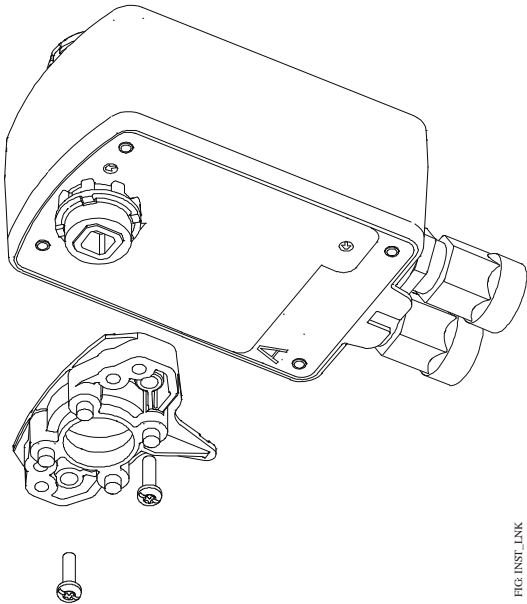

**Figure 13: Installing the Linkage**

6. Insert fixed pointer and M4x0.7x83 mm long screw into the Side B actuator hub (Figure 14). Direct the arrow on the pointer to 0%.

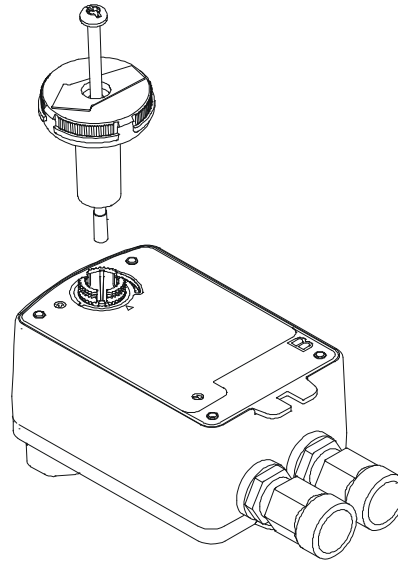

**Figure 14: Installing the Fixed Pointer**

7. Install the actuator on the ball valve (Figure 15). Tighten the actuator mounting screw to a torque of 10 to 12 lb-in. (1.1 to 1.4 N-m) and snap the large adjustable pointer into place.

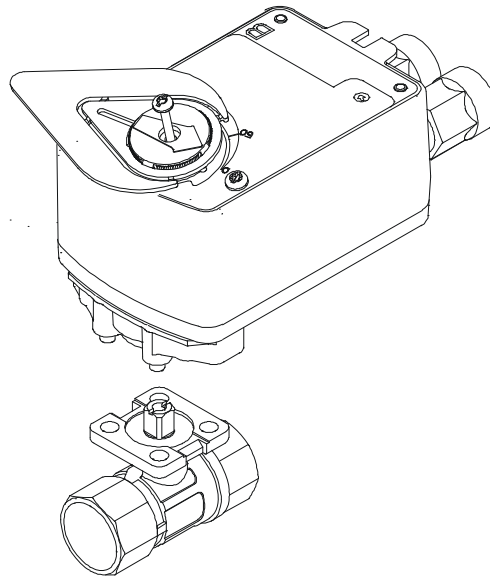

**Figure 15: Mount the Actuator**

## Mounting the Thermal Barrier

Figure 16 shows the optional M9000-561 Thermal Barrier.

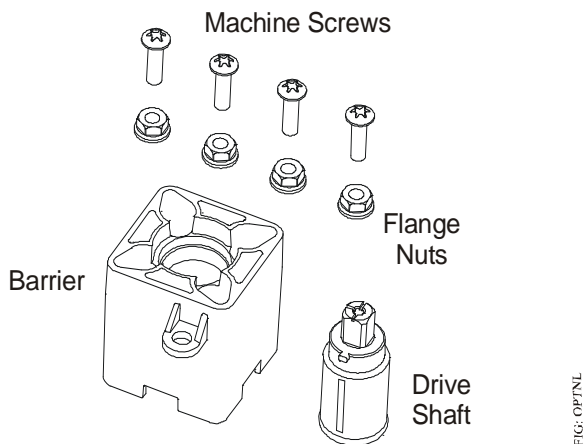

**Figure 16: Optional M9000-561 Thermal Barrier**

To mount the optional thermal barrier:

1. Install the thermal barrier drive shaft into the thermal barrier by aligning the tab on the drive shaft with the slot on the thermal barrier (Figure 17).

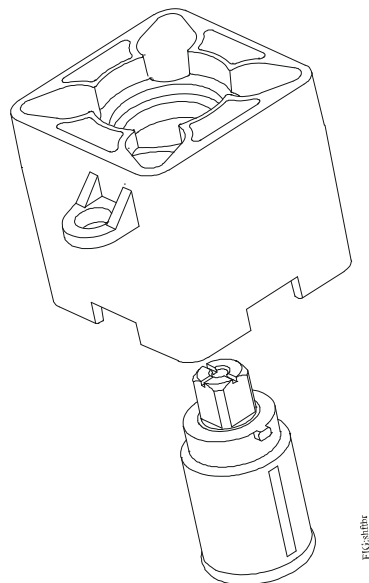

**Figure 17: Installing the Drive Shaft into the Thermal Barrier**

2. Rotate the drive shaft to align marks on the top of the thermal drive shaft with matching marks on the valve stem.
3. Mount the thermal barrier onto the valve using the four included M5x16 mm machine screws and four M5 flange nuts. Tighten the screws to a recommended torque of 21 to 25 lb·in. (2.4 to 2.8 N·m). (Figure 18).

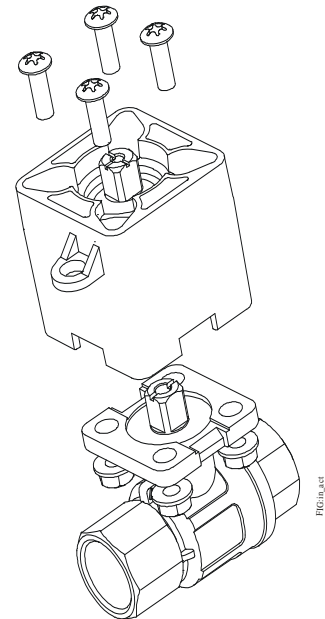
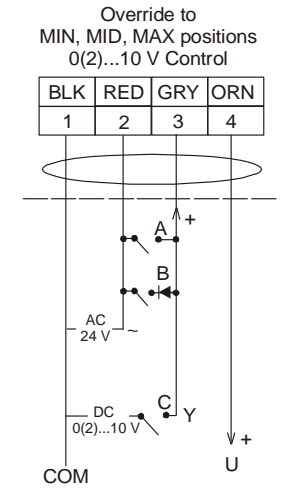
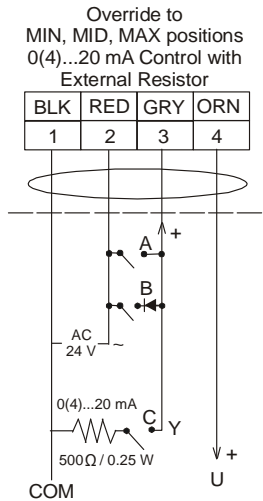
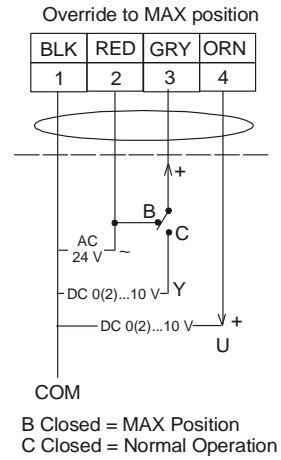
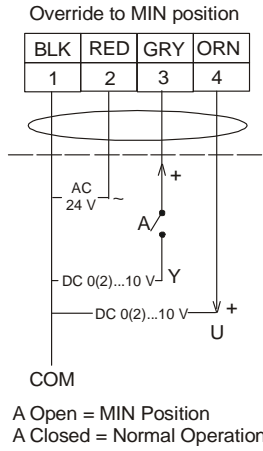
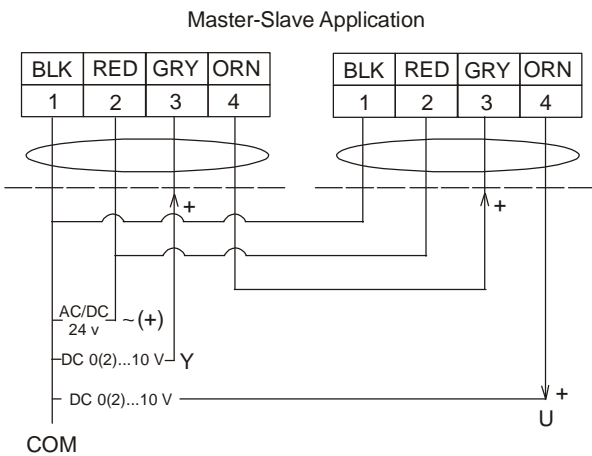
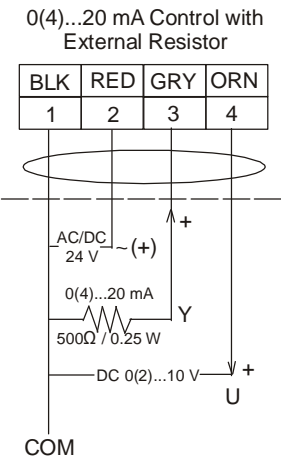
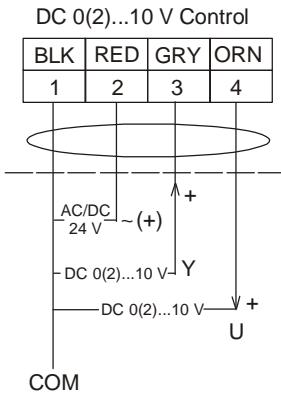

**Figure 18: Installing the Barrier**

4. Proceed to actuator mounting instructions. Follow the same steps as mounting directly to the valve when mounting the actuator to the thermal barrier.

# Wiring

See Figure 19, Figure 20, and Figure 21 to wire the applicable VA9203-GGx-xx Series model.



FUNCTION	A	B	C
0% ( MIN )	—	—	—
50% ( MID )	—	—	—
100% ( MAX )	—	—	—
NORMAL	—	—	—

FUNCTION	A	B	C
0% ( MIN )	—	—	—
50% ( MID )	—	—	—
100% ( MAX )	—	—	—
NORMAL	—	—	—

Figure 20: Control Wiring Diagrams (Overrides)

Figure 19: Control Wiring Diagrams



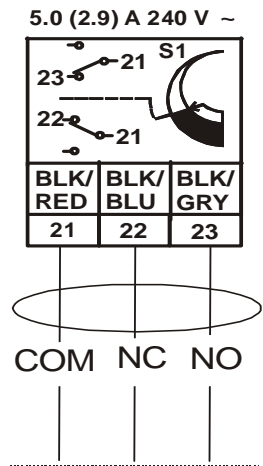

**Figure 21: Auxiliary Switch Wiring Diagram**

**WARNING: Risk of Electric Shock.** Disconnect or isolate all power supplies before making electrical connections. More than one disconnect or isolation may be required to completely de-energize equipment. Contact with components carrying hazardous voltage can cause electric shock and may result in severe personal injury or death.

**CAUTION: Risk of Property Damage.** Do not apply power to the system before checking all wiring connections. Short circuited or improperly connected wires may result in permanent damage to the equipment.

**CAUTION: Risk of Property Damage.** Insulate and secure each unused wire lead before applying power to the actuator. Failure to insulate and secure each unused wire lead may result in property damage.

**IMPORTANT:** Make all wiring connections in accordance with the National Electrical Code and local regulations. Use proper Electrostatic Discharge (ESD) precautions during installation and servicing to avoid damaging the electronic circuits of the actuator.

**Using Conduit**

All VA9203 Series Actuators accept 1/2 in. (13 mm) threaded electrician's fittings.(Figure 22).

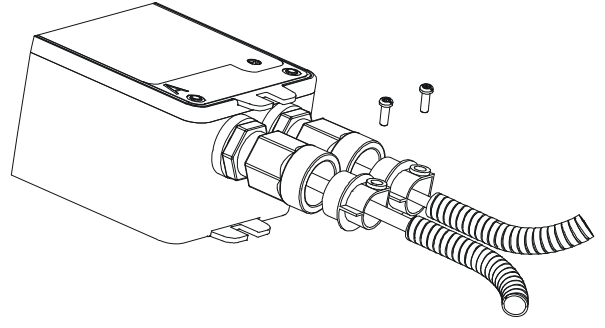

**Figure 22: Adding Flexible Metal Conduit**

1. Feed the actuator cables through the field supplied electrician's fitting and conduit.
2. Thread the electrician's fitting into the actuator and secure the conduit to the fitting in accordance with local building code requirements.

**Setup and Adjustments**

**Mode Selection Switch**

Actuators have an external mode selection switch to calibrate, select the input signal range, and to reverse the control logic. The switch is accessible from both the A and B sides of the actuator (Figure 23). Actuators are delivered in Direct Acting (DA), DC 0 to 10 V input signal mode. To change to Reverse Acting (RA) mode, move the mode selection switch from DA to RA. The input signal range is selectable between DC 0 to 10 V or DC 2 to 10 V. If the CAL function is not used, both input signal ranges are proportioned across the full rotation range of 0 to 95° rotation.









For example, if a DC 0 to 10 V input signal is selected an the rotation range is limited to 75, the rotation range lit will be reached at DC 8.3 V.

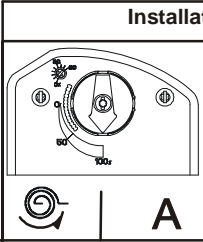
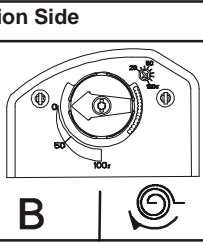
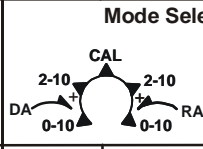
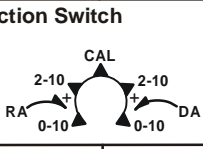

**Figure 23: Mode Selection**

## Control Response

The installation side of the actuator and the position of the mode selection switch combine to determine control response from the actuator (Figure 24).

		Installation Side						
								
								
Input Signal								
Increasing								
Decreasing								
Direction	Feedback	Rotation Position						
		0°*	15°	30°	45°	60°	75°	90°
Direct Acting	0-10 V	0.0 V	1.7 V	3.3 V	5.0 V	6.7 V	8.3 V	10.0 V
	2-10 V	2.0 V	3.3 V	4.7 V	6.0 V	7.3 V	8.7 V	10.0 V
Reverse Acting	0-10 V	10.0 V	8.3 V	6.7 V	5.0 V	3.3 V	1.7 V	0.0 V
	2-10 V	10.0 V	8.7 V	7.3 V	6.0 V	4.7 V	3.3 V	2.0 V

\* 0° is the spring return position.

**Figure 24: Control Response**

## Calibration (CAL) Function

The CAL function enables the actuator to redefine the selected input signal range proportionally across a reduced rotation range. The actuator maintains calibration when power is lost or removed.

Follow these steps to calibrate the input signal range:

1. With power applied to the actuator, move the mode selection switch to the CAL position and leave it in this position for approximately 5 seconds. The actuator begins rotating until the end-stops are found.
2. Move the mode selection switch to the desired input signal range. Selection can be made while the calibration process is in progress, or after it is complete. The selected input signal is proportionally reconfigured to the reduced rotation range.

**Note:** During normal operation, if the actuator stroke increases due to seal or seat wear, input signals are automatically reconfigured to the increased rotation range in approximately 0.5° increments.

3. If the actuator mounting position is changed or if the linkage is adjusted, repeat Step 1 and Step 2 to repeat the CAL function.

**Note:** The mode selection switch must remain out of the CAL position for at least 2 seconds before re-initiating the CAL function.

**Note:** If the mode selection switch is left in the CAL position, the actuator defaults to 0-10 V input signal range, DA.

### **Auxiliary Switch (VA9203-xxB-xx Models)**

The VA9203-xxB-xx models include one integral auxiliary switch with a switch adjuster accessible on either face of the actuator (Figure 25). The factory setting for Auxiliary Switch is 10% closing (relative to the 0 to 100% rotation range as printed on the product label). See the Technical Specifications table for the auxiliary switch ratings.



#### **WARNING: Risk of Electric Shock and Property Damage.**

Insulate and secure each unused wire lead before applying power to the actuator. Failure to insulate and secure each unused wire lead may result in property damage, electric shock, and severe personal injury or death.

The switch point is continuously adjustable throughout the actuators's rotation range. For the most accurate switch positioning, see Figure 25 and use the method in the following example. To change the switch point of auxiliary switch, proceed as follows:

1. Position the actuator in the full spring return position.

**Note:** The switch is factory set to trip when the actuator reaches the 10% position.

2. Rotate the switch adjuster until it points to the desired switch point.
3. Connect the Auxiliary Switch to a power source or an ohmmeter and apply power to the actuator. The actuator moves to the fully open position and holds while power is applied.
4. Observe the switch point. If required, repeat Step 1 through Step 3.

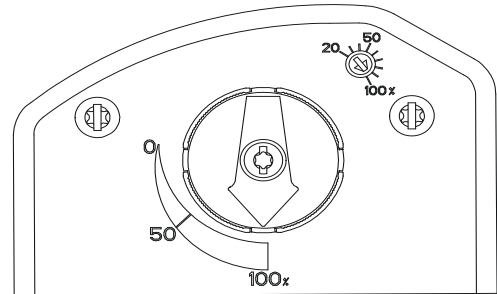

**Figure 25: Switch Trip Point Settings**

### **Repair Information**

A number of replacement parts are available; see Table 4 for more details. If an VA9203 Series Electric Spring Return Actuator fails to operate within its specifications, replace the unit. For a replacement electric actuator, contact the nearest Johnson Controls representative.

## Technical Specifications

### VA9203-GGx-2Z Series Proportional Electric Spring Return Actuator (Part 1 of 2)

<b>Power Requirements</b>		AC 24 V (AC 19.2 V to 28.8 V) at 50/60 Hz: Class 2 (North America) or Safety Extra-Low Voltage (SELV) (Europe), 4.7 VA Running, 2.7 VA Holding Position DC 24 V (DC 21.6 V to 28.8 V): Class 2 (North America) or SELV (Europe) 1.8 W Running, 1 W Holding Position Minimum Transformer Size: 6 VA per Actuator
<b>Input Signal/Adjustments</b>		Factory Set at DC 0 to 10 V, CW Rotation with Signal Increase Selectable DC 0 (2) to 10 V or 0 (4) to 20 mA with Field -Furnished 500 ohm 0.25 W Minimum Resistor Switch Selectable Direct or Reverse Action with Signal Increase
<b>Control Input Impedance</b>		Voltage Input: 100,000 ohm Current Input: 500 ohm with Field Furnished 500 ohm Resistor
<b>Feedback Signal</b>		DC 0 (2) to 10 V for Desired Rotation Range up to 95° Corresponds to Rotation Limits, 0.5 mA at 10 V Maximum
<b>Auxiliary Switch Rating</b>	<b>-xxB Models</b>	One Single-Pole, Double-Throw (SPDT), Double-Insulated Switch with Silver Contacts: AC 24 V, 50 VA Pilot Duty AC 120 V, 5.8 A Resistive, 1/4 hp, 275 VA Pilot Duty AC 240 V, 5.0 A Resistive, 1/4 hp, 275 VA Pilot Duty
<b>Spring Return</b>		Direction is Selectable with Mounting Position of Actuator: Actuator Face Labeled A is Away from Valve: CCW Spring Return Actuator Face Labeled B is Away from Valve: CW Spring Return
<b>Rated Torque</b>	<b>Power On (Running)</b>	27 lb-in (3 N·m) All Operating Temperatures
	<b>Power Off (Spring Returning)</b>	27 lb-in (3 N·m) All Operating Temperatures
<b>Rotation Range</b>		Maximum Full Stroke: 95° Adjustable Stop: 35° to 95° Maximum Position
<b>Rotation Time for 90 Degrees of Travel</b>	<b>Power On (Running)</b>	90 Seconds Constant for 0 to 27 lb-in. (3 N·m) Load, at all Operating Conditions
	<b>Power Off (Spring Returning)</b>	12 to 17 Seconds for 0 to 27 lb-in. (3 N·m) Load, at Room Temperature 16 Seconds Nominal at Full Rated Load 22 Seconds Maximum with 27 lb-in. (3 N·m) Load, at -22°F (-30°C)
<b>Life Cycles</b>		60,000 Full Stroke Cycles with 27 lb-in. (3 N·m) Load 1,500,000 Repositions with 27 lb-in. (3 N·m) Load
<b>Audible Noise Rating</b>	<b>Power On (Running)</b>	<37 dBA at 27 lb-in. (3 N·m) Load, at a Distance of 39-13/32 in. (1 m)
	<b>Power On (Holding)</b>	<20 dBA at a Distance of 39-13/32 in. (1 m)
	<b>Power Off (Spring Returning)</b>	<56 dBA at 27 lb-in. (3 N·m) Load, at a Distance of 39-13/32 in. (1 m)
<b>Electrical Connections</b>	<b>GGA-2Z Models</b>	120 in. (3.05 m) UL 444 Type CMP Plenum Rated Cable with 19 AWG (0.75 mm <sup>2</sup> ) Conductors and 1/4 in. (6 mm) Ferrule Ends
	<b>GGB-2Z Models</b>	48 in. (1.2 m) UL 758 Type AWM Halogen Free Cable with 18 AWG (0.85 mm <sup>2</sup> ) Conductors and 1/4 in. (6 mm) Ferrule Ends
<b>Conduit Connections</b>		Integral 1/2 in. (13 mm) Threaded Conduit Connector(s)

## VA9203-GGx-2Z Series Proportional Electric Spring Return Actuator (Part 2 of 2)

<b>Fluid Temperature Limits</b>	<b>VG12x1 and VG18x1 Series</b>	23 to 203°F (-5 to 95°C), Not Rated for Steam Service
	<b>VG12x5 and VG18x5 Series</b>	-22 to 212°F (-30 to 100°C), Not Rated for Steam Service
	<b>VG12x5 and VG18x5 Series with M9000-561 Thermal Barrier Installed</b>	-22 to 284°F (-30 to 140°C) water; 15 psig (103 kPa) at 250°F (121°C) Saturated Steam
<b>Ambient Conditions</b>	<b>Standard Operating</b>	-22 to 140°F (-30 to 60°C); 90% RH Maximum, Noncondensing
	<b>Storage</b>	-40 to 185°F (-40 to 85°C); 95% RH Maximum, Noncondensing
<b>Enclosure Rating</b>		NEMA 2 (IP54) for all Mounting Directions
<b>Compliance</b>  CE	<b>United States</b>	UL Listed, CCN XAPX, File E27734; to UL 60730-1A: 2003-08, Ed. 3.1, Automatic Electrical Controls for Household and Similar Use; and UL 60730-2-14: 2002-02, Ed. 1, Part 2 Particular Requirements for Electric Actuators Plenum Rated (UL 2043). Suitable for use in other environmental air space (plenums) in accordance with Section 300.22 (C) of the National Electric Code
	<b>Canada</b>	UL Listed, CCN XAPX7, File E27734; to UL 60730-1:02-CAN/CSA: July 2002, 3rd Ed., Automatic Electrical Controls for Household and Similar Use; and CSA C22.2 No. 24-93 Temperature Indicating and Regulating Equipment
	<b>Europe</b>	CE Mark – Johnson Controls, Inc., declares that this product is in compliance with the essential requirements and other relevant provisions of the EMC Directive 2004/108/EC and Low Voltage Directive 2006/95/EC
	<b>Australia and New Zealand</b>	C-Tick Mark, Australia/NZ Emissions Compliant
<b>Shipping Weight</b>	<b>-GGA Models</b>	2.0 lb (0.9 kg)
	<b>-GGB Models</b>	2.4 lb (1.1 kg)



**Building Efficiency**  
507 E. Michigan Street, Milwaukee, WI 53202

*Metasys® and Johnson Controls® are registered trademarks of Johnson Controls, Inc. All other marks herein are the marks of their respective owners. © 2013 Johnson Controls, Inc.*