

# M9208-GGx-x Series Proportional Electric Spring Return Actuators

## Installation Instructions

M9208-GGA-3, M9208-GGC-3, M9208-GGA-2

Part No. 34-636-2189, Rev. C

Issued February 1, 2013

Supersedes May 13, 2011

Refer to the [QuickLIT Web site](#) for the most up-to-date version of this document.

### Applications

The M9208-GGx-x Series Proportional Electric Spring Return Actuators are direct-mount actuators that operate on AC/DC 24 V power. These bidirectional actuators do not require a damper linkage, and are easily installed on round shafts from 5/16 to 5/8 in. (8 to 16 mm) or square shafts from 1/4 to 1/2 in. (6 to 12 mm) using the standard shaft clamp included with the actuator. An optional M9208-600 Large Coupler Kit is available for round shafts from 1/2 to 3/4 in. (12 to 19 mm) or square shafts from 3/8 to 9/16 in. (10 to 14 mm).

A single M9208-GGx-x Series Proportional Electric Spring Return Actuator provides 70 lb-in. (8 N·m) running and spring return torque. Integral line voltage auxiliary switches, available only on the M9208-xxC-3 models, indicate end-stop position, or perform switching functions within the selected rotation range.

M9208-GGA-2 actuators include plenum-rated cables and are specially configured for installation in spaces used for environmental air-handling purposes other than ducts and plenums as specified in National Fire Protection Association (NFPA) 70: National Electrical Code section 300.22(C), Other Space Used for Environmental Air. The space over a hung ceiling used for environmental air handling purposes is an example of the type of space for which these actuators are configured.

**IMPORTANT:** Use this M9208-GGx-x Series Proportional Electric Spring Return Actuator only to control equipment under normal operating conditions. Where failure or malfunction of the electric actuator could lead to personal injury or property damage to the controlled equipment or other property, additional precautions must be designed into the control system. Incorporate and maintain other devices, such as supervisory or alarm systems or safety or limit controls, intended to warn of or protect against failure or malfunction of the electric actuator.

### Installation

The M9208-GGx-x Series Proportional Electric Spring Return Actuators mount directly to the surface in any convenient orientation using two No. M3.5 x 9.5 mm self-drilling sheet metal screws and the anti-rotation bracket (parts included with the actuator). No additional linkages or couplers are required. Electrical connections are color-coded and identified with numbers permanently marked on the actuator cable. A tag on the actuator cable identifies the electrical connections and wiring details are included on the actuator housing.

**IMPORTANT:** Before specifying M9208-GGx-x Series Proportional Electric Spring Return Actuators for plenum applications, verify acceptance of exposed plastic materials in plenum areas with the local building authority. Building codes for plenum requirements vary by location. Some local building authorities accept compliance to UL 1995, Heating and Cooling Equipment, while others use different acceptance criteria.

**IMPORTANT:** Do not install or use this M9208-GGx-x Series Proportional Electric Spring Return Actuators in or near environments where corrosive substances or vapors could be present. Exposure of the electric actuator to corrosive environments may damage the internal components of the device, and will void the warranty.

### Parts Included

- M9208-GGx-x actuator
- M9208-603 adjustable stop kit
- M9000-604 anti-rotation bracket with two No. M3.5 x 9.5 mm, pan-head, cross-recessed (Phillips), self-drilling and self-tapping screws
- Manual override crank with 3M® Dual Lock® adhesive-backed strip
- Two No. 10-32 x 9/16 in. conduit connector screws

### Special Tools Needed

- 10 mm wrench/socket
- drill with Phillips bit, driver size 1

## Dimensions

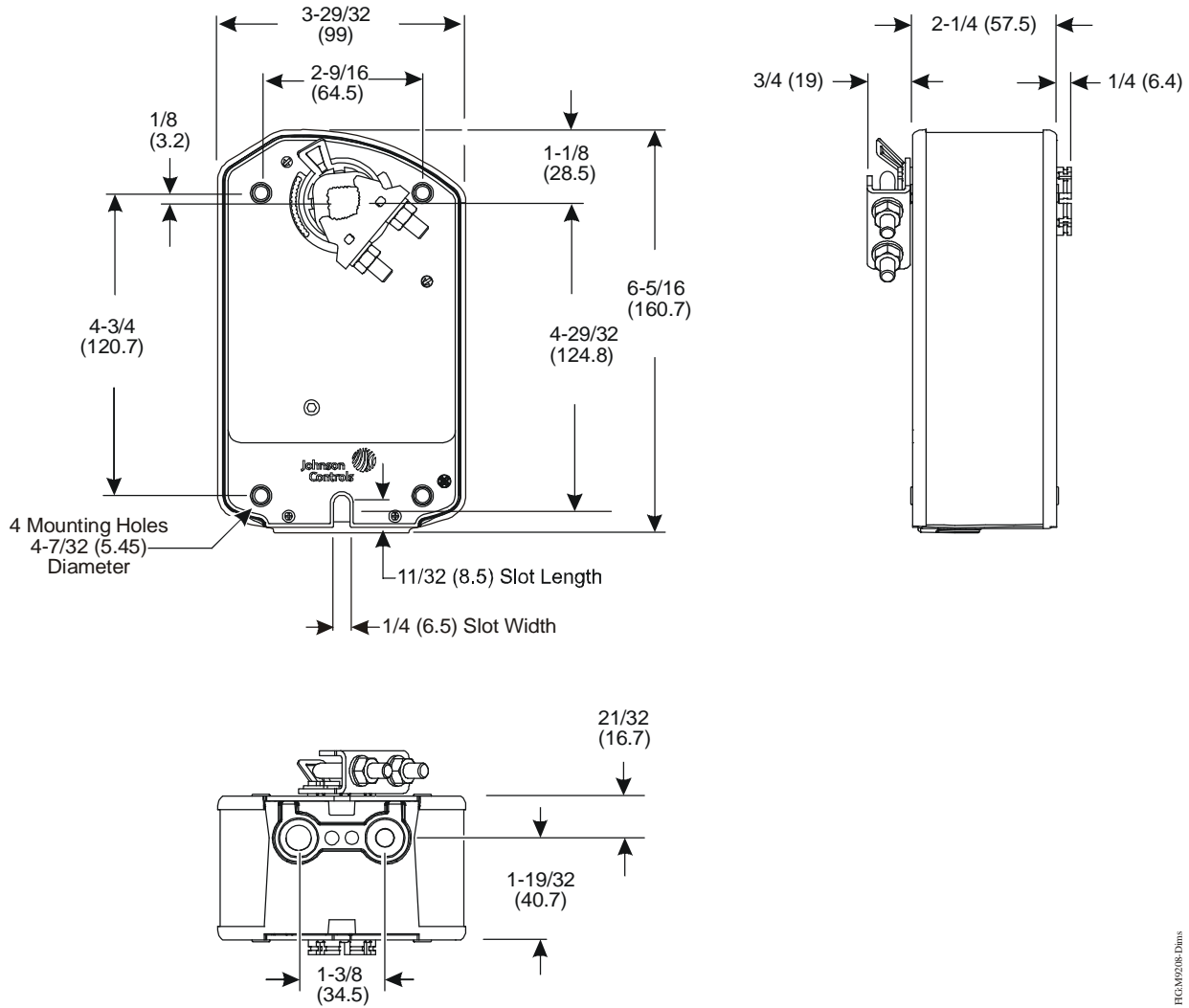

FIG.M9208-Dims

**Figure 1: M9208-GGx-x Series Proportional Electric Spring Return Actuator Dimensions, in. (mm)**

## Accessories

**Table 1: Accessories and Replacement Parts (Order Separately)**

<b>Code Number</b>	<b>Description</b>
<b>DMPR-KC003<sup>1</sup></b>	7 inch- (178 mm-) Blade Pin Extension (without bracket) for Johnson Controls® Direct-Mount Damper Applications (quantity 1)
<b>M9000-200</b>	Commissioning Tool that provides a control signal to drive 24 V On/Off, Floating, Proportional, and/or Resistive Electric Actuators (quantity 1)
<b>M9000-321</b>	Weathershield Kit for Damper Application of M9203 and M9208 Series Electric Spring Return Actuators (quantity 1)
<b>M9000-400</b>	Jackshaft Linkage Kit. Open-ended design enables clamping onto a jackshaft without requiring access to the ends of the jackshaft. (quantity 1)
<b>M9000-560</b>	Ball Valve Linkage Kit for applying M9203 and M9208 Series Electric Spring Return Actuators to VG1000 Series Valves (quantity 1)
<b>M9000-604</b>	Replacement Anti-Rotation Bracket Kit for M9208, M9210, and M9220 Series Electric Spring Return Actuators (quantity 1)
<b>M9000-606</b>	Position Indicator for Damper Applications of M9203 and M9208 Series Actuators (quantity 5)
<b>M9200-100</b>	Threaded Conduit Adapter, 1/2 NPSM, for M9210(20) and M(VA)9208 Series Actuators (quantity 5)
<b>M9208-100</b>	Remote Mounting Kit, including Mounting Bracket, M9208-150 Crankarm, Ball Joint, and mounting fasteners (quantity 1)
<b>M9208-150</b>	Crankarm Adapter Kit (quantity 1)
<b>M9208-600</b>	Large Shaft Coupler Kit (with Locking Clip) for Mounting M9208 Series Electric Spring Return Actuators on dampers with round shafts from 1/2 to 3/4 in. (12 to 19 mm) or square shafts from 3/8 to 9/16 in. (10 to 14 mm) (quantity 1)
<b>M9208-601</b>	Replacement Standard Coupler Kit (with Locking Clip) for mounting M9208 Series Electric Spring Return Actuators on dampers with round shafts from 5/16 to 5/8 in. (8 to 16 mm) or square shafts from 1/4 to 1/2 in. (6 to 12 mm) (quantity 1)
<b>M9208-602</b>	Replacement Locking Clips for M9208 Series Electric Spring Return Actuators (quantity 5)
<b>M9208-603</b>	Adjustable Stop Kit for M9208 Series Electric Spring Return Actuators (quantity 1)
<b>M9208-604</b>	Replacement Manual Override Cranks for M9208 Series Electric Spring Return Actuators with long crank radius: 2.83 in. (72 mm) (quantity 5)
<b>M9208-605</b>	Replacement Manual Override Cranks for M9208 Series Electric Spring Return Actuators with short crank radius: 1.83 in. (46.5 mm) (quantity 5)

1. Furnished with the damper and may be ordered separately.

## Mounting

The M9208-GGx-x Series Proportional Electric Spring Return Actuators can be easily installed on dampers with round shafts from 5/16 to 5/8 in. (8 to 16 mm) or square shafts from 1/4 to 1/2 in. (6 to 12 mm) using the standard shaft coupler included with the actuator. An optional M9208-600 Large Shaft Coupler Kit adapts to larger shaft sizes; see Table 1 for more details. If the damper shaft extends less than 3.31 in. (84 mm), see the Removable Coupler section for further instructions. If the damper shaft extends less than 0.79 in. (20 mm), install a shaft extension recommended by the damper manufacturer.

### **Counterclockwise (CCW) Spring Return Direction – Clockwise (CW) Powered Operation**

For CCW spring return direction, mount the actuator to the damper shaft so that Side A of the actuator is away from the damper as illustrated in Figure 2. With power applied, the actuator drives CW from the 0° position and spring returns CCW.

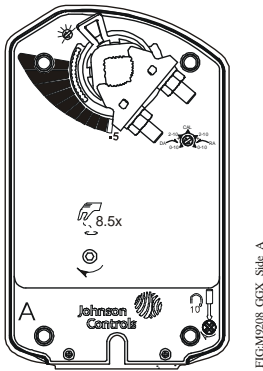

Figure 2: Actuator Side A

### **Clockwise (CW) Spring Return Direction – Counterclockwise (CCW) Powered Operation**

For CW spring return direction, mount the actuator to the damper shaft so that Side B of the actuator is away from the damper as illustrated in Figure 3. With power applied, the actuator drives CCW from the 0° position and spring returns CW.

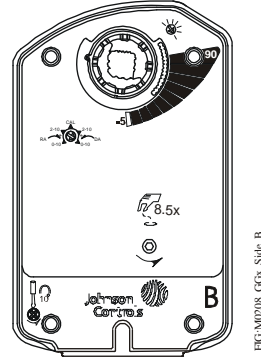

Figure 3: Actuator Side B

### **Removable Coupler**

If the damper shaft extends less than 3.31 in. (84 mm), mount the coupler on the face of the actuator closest to the damper.

If the damper shaft extends less than 0.79 in. (20 mm), a shaft extension is required to mount the actuator.

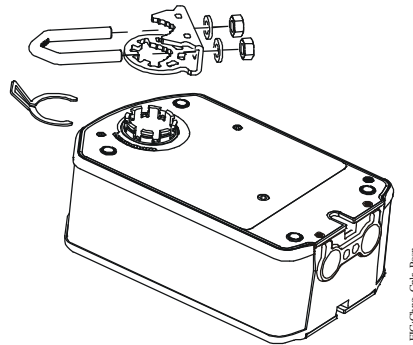

Figure 4: Changing the Coupler Position

To change the coupler's position, see Figure 4 and proceed as follows:

1. Mount the coupler on either Side A or Side B of the actuator as determined by the shaft length.
2. Snap the locking clip securely into the coupler retention groove to retain the coupler.

## Manual Override

Use only the supplied manual override crank to reposition the actuator hub when using the manual override feature.

**IMPORTANT:** Applying excessive torque to the manual override or operating the manual override with a power tool may damage the internal components of the actuator and cause premature failure.

To reposition the actuator hub, proceed as follows:

1. De-energize the actuator.
2. Insert the hex end of the manual override crank into the manual override adjustment point on the face of the actuator.
3. Rotate the manual override crank in the direction indicated by the arrow on the label.
4. The actuator requires 8-1/2 manual override crank rotations from the full spring return position to fully reposition the actuator hub. At the end of travel, the rotation resistance increases. Do not force the manual crank past this point.
5. While holding the manual crank in the wound position, rotate and hold the red lock shaft approximately 10° then release the manual crank to lock the actuator hub in place.

**Note:** Insert and slightly rotate the manual crank in the direction indicated by the arrow on the label to unlock the actuator hub. Alternately, the actuator hub automatically unlocks when power is applied to the actuator, and returns the actuator to normal drive and spring return operation.

## Mounting the Actuator

To mount the actuator, proceed as follows:

1. See the dimensions in Figure 5 and Table 2 to ensure the correct positioning of the anti-rotation bracket.

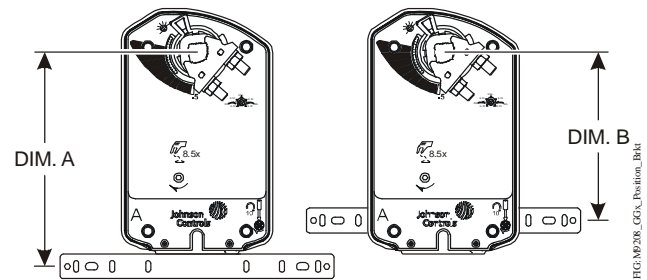

Figure 5: Positioning the Anti-Rotation Bracket

Table 2: Dimensions from Anti-Rotation Bracket to Shaft Center

Shaft Diameter, in. (mm)	Dimension A, in. (mm)	Dimension B, in. (mm)
5/16 to 5/8 (8 to 16)	5-7/16 (138.4)	4-5/32 (105.6)
1/2 to 3/4 (12 to 19)	5-13/32 (137.4)	4-1/8 (104.6)

**IMPORTANT:** The tab on the anti-rotation bracket must fit midpoint in the actuator slot. Positioning the tab midpoint in the slot prevents actuator binding and premature wear, and makes actuator removal easier.

2. Bend or cut the anti-rotation bracket to fit the damper frame or duct as illustrated in Figure 6.  
**Note:** The anti-rotation bracket can be bent to fit a round damper.
3. Mark or drill mounting holes in the damper frame or duct using the anti-rotation bracket as a guide (based on the measurements obtained in Table 2 and Figure 5).
4. Secure the anti-rotation bracket to the damper frame or duct using the two No. M3.5 x 9.5 mm self-drilling sheet metal screws provided.

**IMPORTANT:** Do not overtighten the mounting screws to avoid stripping the threads. Be certain that the tab on the anti-rotation bracket remains properly positioned in the slot on the actuator, and that the actuator remains parallel to the mounting surface.

5. Slide the actuator onto the damper shaft, and position the anti-rotation bracket tab into the slot at the bottom of the actuator as illustrated in Figure 6.

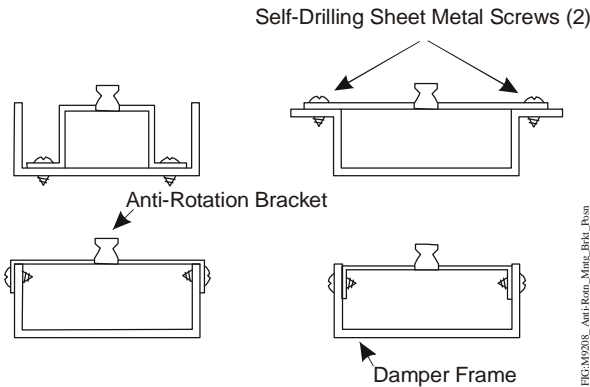
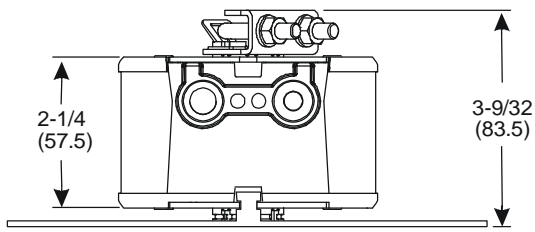

FIGM9208\_AntiRot\_Mntg\_Bkt\_Pos

**Figure 6: Anti-Rotation Mounting Bracket Positions**

**Note:** If electric power is not available, complete this verification by reinserting the manual override crank and turning it in the direction indicated to rotate the hub to the fully open position.

**Limiting Rotation Range Using M9208-603 Adjustable Stop Kit**

The actuator is factory set for 95° rotation, and its range is limited in 5° increments to a minimum of 35°. A stroke-limiting stop can be attached in the field to the shaft coupler side of the actuator to reduce the rotation range. Attaching the stroke-limiting stop in the furthest mounting position reduces the rotation range of the actuator by 5°. Each progressive mounting position reduces the rotation range an additional 5°.

1. Check that the damper blade is visible or its position is permanently marked on the end of the damper shaft, as illustrated in Figure 7.

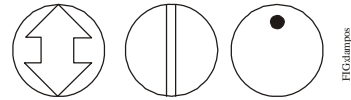

FIGDamp

**Figure 7: Damper Position Icons**

6. Rotate the damper blade(s) to the desired position if the power is lost. To ensure a tight seal, insert the manual override crank and turn it in the direction indicated by the arrow. The position indicator should be near the 0° position on the scale. While holding the manual crank in the wound position, rotate and hold the red lock shaft approximately 10° then release the manual crank to temporarily lock the actuator hub in place.
7. Hold the actuator perpendicular to the damper shaft. Evenly hand-tighten each nut on the coupler U-bolt, then torque the coupler U-bolt nuts to 100 to 125 lb-in. (11 to 14 N·m).
8. To manually unlock the actuator hub, rotate the manual override crank slightly in the direction indicated by the arrow and remove it. Alternately, the hub automatically unlocks when power is applied to the actuator.
9. Store the manual override crank by applying the 3M® Dual Lock® adhesive-backed strip to the manual crank and a convenient surface of the actuator.
10. Apply power long enough for the actuator to travel a full stroke. Verify that the actuator rotates freely throughout the range.

2. Position the stroke-limiting stop in the serrated slot with its leading edge at the scale position matching the desired stroke.
3. The product label marks hole positions for the M3-0.5 x 8 mm self-tapping screw provided with the adjustable stop kit. Drive the screw through the slot in the adjustable stop and into the actuator face over a marked hole position. (See Figure 8.)

**Note:** The minimum rotation range is 35°.

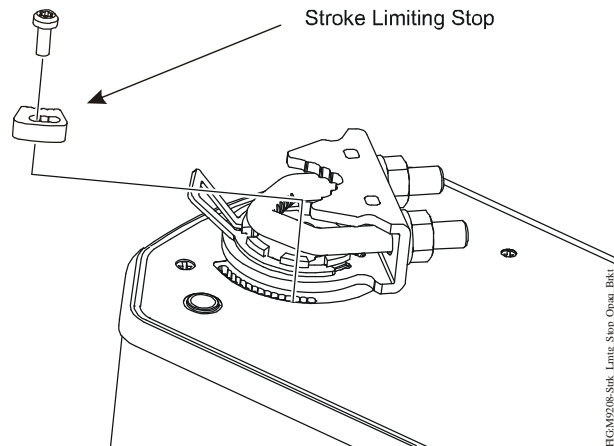

FIGM9208-Strk\_Limiting\_Stop\_Opug\_Erkt

**Figure 8: Limiting Rotation Range**

# Wiring

See Figure 9, Figure 10, and Figure 11 to wire the applicable M9208-GGx-x Series model.

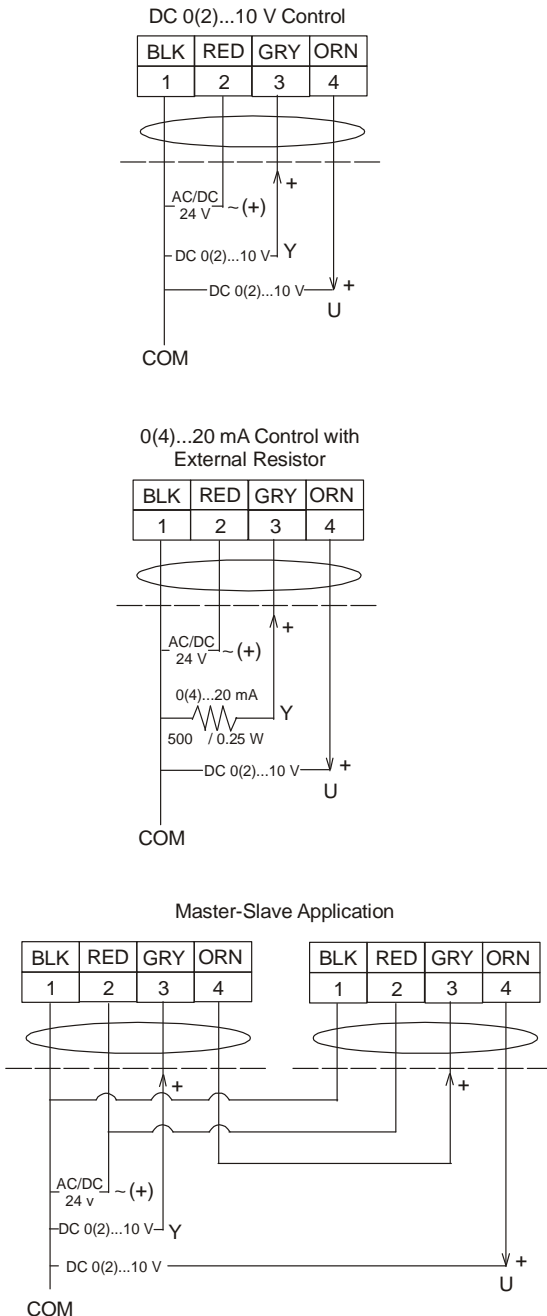

**Figure 9: Control Wiring Diagrams**

**IMPORTANT:** Do not install multiple M9208-GGx-x Series Actuators connected to the same mechanical load. Master-Slave application of M9208-GGx-x Series Actuators requires that each actuator be connected to independent loads.

**Note:** In Master-Slave applications, the slave actuator lags the master actuator position by a few seconds.

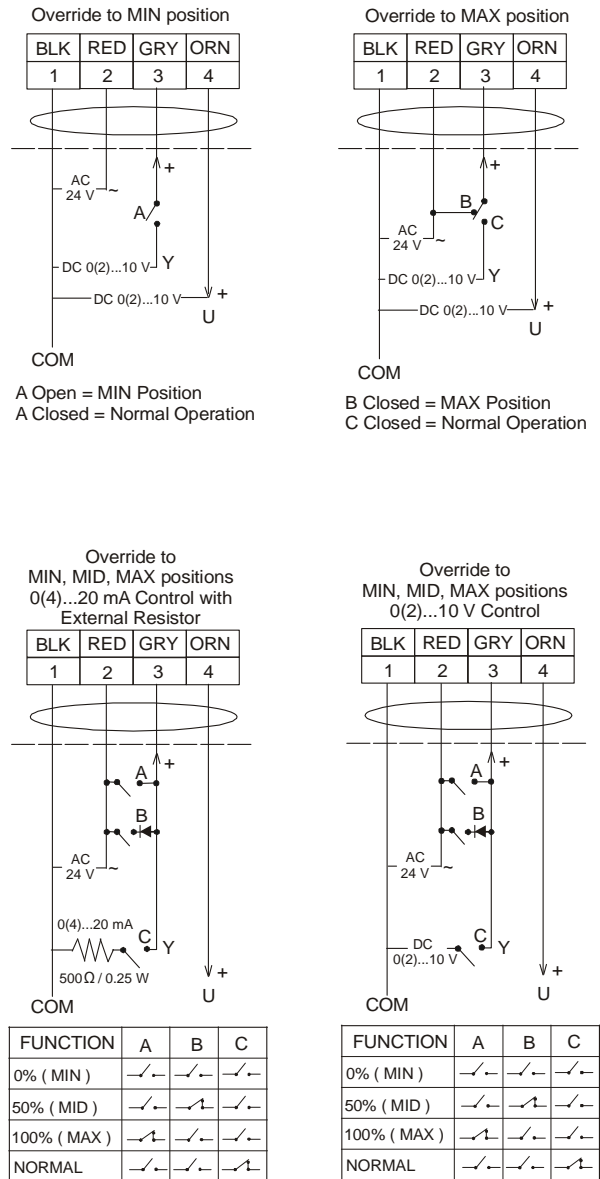

**Figure 10: M9208-GGx-3 Control Wiring Diagram (Overrides)**

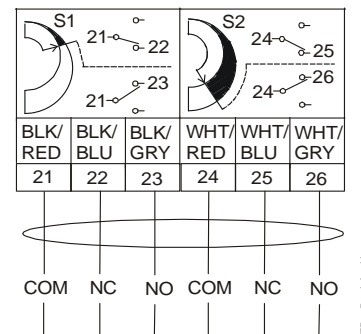

**Figure 11: Auxiliary Switch Wiring Diagram**





**WARNING: Risk of Electric Shock.**

Disconnect or isolate all power supplies before making electrical connections. More than one disconnect or isolation may be required to completely de-energize equipment. Contact with components carrying hazardous voltage can cause electric shock and may result in severe personal injury or death.



**CAUTION: Risk of Property Damage.**

Do not apply power to the system before checking all wiring connections. Short circuited or improperly connected wires may result in permanent damage to the equipment.



**CAUTION: Risk of Property Damage.**

Insulate and secure each unused wire lead before applying power to the actuator. Failure to insulate and secure each unused wire lead may result in property damage.

**IMPORTANT:** Make all wiring connections in accordance with the National Electrical Code and local regulations. Use proper Electrostatic Discharge (ESD) precautions during installation and servicing to avoid damaging the actuator's electronic circuits.

**Using Conduit**

All M9208 Series Actuators accept 3/8 in. trade size flexible metal conduit.

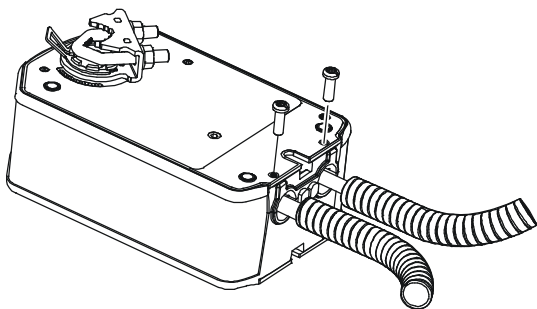

**Figure 12: Adding Flexible Metal Conduit**

- 1. Feed the actuator cables through the field supplied conduit.

- 2. Push the conduit into the holes in the actuator and secure it with the supplied 10-32 x 9/16 in. screws, as illustrated in Figure 12. The product label marks the position of holes for the screws. Drive the screws through the product label in the marked positions. Drive the screwhead flush with the plate to secure the conduit.

**IMPORTANT:** Careful workmanship is required to secure flexible metal conduit. Cut the conduit end perpendicular to its axis. Insert the cut end into the bottom of the holes in the actuator and hold the conduit in place while securing it with the screws provided. Check a completed installation by pulling on the conduit to ensure its retention.

**Setup and Adjustments**

**Mode Selection Switch**

Actuators have an external mode selection switch to calibrate, select input signal range, and reverse control logic. The switch is accessible from both A and B sides of the actuator as illustrated in Figure 13. Actuators are delivered in Direct Acting (DA), DC 0 to 10 V input signal mode. To change to Reverse Acting (RA) mode, move the mode selection switch from DA to RA. The input signal range is selectable between DC 0 to 10 V or DC 2 to 10 V. If the CAL function is not used, both input signal ranges are proportioned across the full rotation range of 0 to 95° rotation.

For example, if a DC 0 to 10 V input signal is selected and the rotation range is limited to 75°, the rotation range limit will be reached at DC 8.3 V.

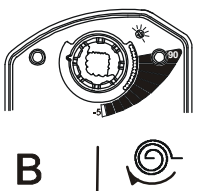
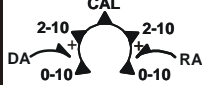

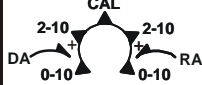











**Figure 13: Mode Selection**



## Control Response

The installation side of the actuator and the position of the mode selection switch combine to determine control response from the actuator. See Figure 14.

		Installation Side							
									
		<b>Mode Selection Switch</b>							
<b>Input Signal</b>									
<b>Increasing</b>									
<b>Decreasing</b>									
<b>Direction</b>	<b>Feedback</b>	<b>Rotation Position</b>							
		0°*	15°	30°	45°	60°	75°	90°	
<b>Direct Acting</b>	0-10 V	0.0 V	1.7 V	3.3 V	5.0 V	6.7 V	8.3 V	10.0 V	
	2-10 V	2.0 V	3.3 V	4.7 V	6.0 V	7.3 V	8.7 V	10.0 V	
<b>Reverse Acting</b>	0-10 V	10.0 V	8.3 V	6.7 V	5.0 V	3.3 V	1.7 V	0.0 V	
	2-10 V	10.0 V	8.7 V	7.3 V	6.0 V	4.7 V	3.3 V	2.0 V	

\* 0° is the spring return position.

**Figure 14: Control Response**

## Calibration (CAL) Function

The CAL function enables the actuator to redefine the selected input signal range proportionally across a reduced rotation range. The actuator maintains calibration when power is lost or removed.

Follow these steps to calibrate the input signal range:

1. With power applied to the actuator, move the mode selection switch to the CAL position and leave it in this position for approximately 5 seconds. The actuator begins rotating until the end-stops are found.
2. Move the mode selection switch to the desired input signal range. Selection can be made while the calibration process is in progress, or after it is complete. The selected input signal is proportionally reconfigured to the reduced rotation range.

**Note:** During normal operation, if the actuator stroke increases due to seal or seat wear, input signals are automatically reconfigured to the increased rotation range in approximately 0.5° increments.

3. If the actuator mounting position is changed or if the linkage is adjusted, repeat Step 1 and Step 2 to repeat the CAL function.

**Note:** The mode selection switch must remain out of the CAL position for at least 2 seconds before re-initiating the CAL function.

**Note:** If the mode selection switch is left in the CAL position, the actuator defaults to 0-10 V input signal range, DA.

## Auxiliary Switch (M9208-xxC-3 Models)

The M9208-xxC-3 models include two integral auxiliary switches with a switch adjuster accessible on either face of the actuator. (See Figure 2 and Figure 3.) The factory setting for Auxiliary Switch No. 1 is 11° closing, and the nominal setting for Auxiliary Switch No. 2 is 81° opening (relative to the 0 to 90° rotation range as printed on the product label). See the [Technical Specifications](#) table for the auxiliary switch ratings.



### **WARNING: Risk of Electric Shock and Property Damage.**

Insulate and secure each unused wire lead before applying power to the actuator. Failure to insulate and secure each unused wire lead may result in property damage, electric shock, and severe personal injury or death.

The switch point of Auxiliary Switch No. 1 is fixed. The switch point of Auxiliary Switch No. 2 is independently and continuously adjustable from 25 to 90° position. For the most accurate switch positioning, see Figure 15 and use the method in the following example.

To change the switch point of auxiliary Switch No. 2, proceed as follows:

1. Position the actuator in the full spring return position.

**Note:** The switch is factory set to trip when the actuator reaches the 81° position.

2. Rotate the switch adjuster until it points to the desired switch point.

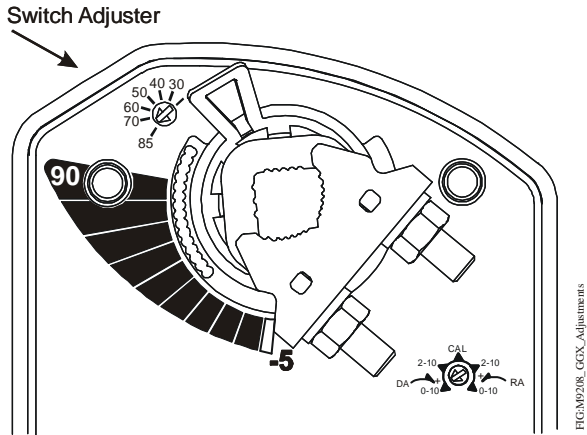

**Figure 15: Switch Trip Point Settings**

3. Connect Auxiliary Switch No. 2 to a power source or an ohmmeter and apply power to the actuator. The actuator moves to the fully open position and holds while power is applied.
4. Observe the switch point. If required, repeat Step 1 through Step 3.

### Repair Information

A number of replacement parts are available; see Table 1 for more details. If an M9208-GGx-x Series Proportional Electric Spring Return Actuator fails to operate within its specifications, replace the unit. For a replacement electric actuator, contact the nearest Johnson Controls representative.

## Technical Specifications

### M9208-GGx-x Series Proportional Electric Spring Return Actuator (Part 1 of 2)

<b>Power Requirements</b>	<b>-GGx Models</b>	AC 24 V (AC 19.2 V to 28.8 V) at 50/60 Hz: Class 2 (North America) or Safety Extra-Low Voltage (SELV) (Europe), 7.9 VA Running, 5.5 VA Holding Position DC 24 V (DC 21.6 V to 28.8 V): Class 2 (North America) or SELV (Europe), 3.5 W Running, 1.9 W Holding Position Minimum Transformer Size: 8 VA per Actuator
<b>Input Signal / Adjustments</b>	<b>-GGx Models</b>	Factory Set at DC 0 to 10 V, CW Rotation with Signal Increase; Selectable DC 0 (2) to 10 V or 0 (4) to 20 mA with Field-Furnished 500 ohm 0.25 W Minimum Resistor; Switch Selectable Direct or Reverse Action with Signal Increase
<b>Control Input Impedance</b>	<b>-GGx Models</b>	Voltage Input: 100,000 ohm Current Input: 500 ohm with Field Furnished 500 ohm Resistor
<b>Feedback Signal</b>	<b>-GGx Models</b>	DC 0 (2) to 10 V for Desired Rotation Range up to 95° Corresponds to Rotation Limits, 0.5 mA at 10 V Maximum
<b>Auxiliary Switch Rating</b>	<b>-xxC Models</b>	Two Single-Pole, Double-Throw (SPDT), Double-Insulated Switches with Gold over Silver Contacts: AC 24 V, 50 VA Pilot Duty AC 120 V, 5.8 A Resistive, 1/4 hp, 275 VA Pilot Duty AC 240 V, 5.0 A Resistive, 1/4 hp, 275 VA Pilot Duty
<b>Spring Return</b>		Direction Is Selectable with Mounting Position of Actuator: Actuator Face Labeled A Is Away from Damper or Valve: CCW Spring Return Actuator Face Labeled B Is Away from Damper or Valve: CW Spring Return
<b>Rated Torque</b>	<b>Power On (Running)</b>	70 lb-in. (8 N·m) All Operating Temperatures
	<b>Power Off (Spring Returning)</b>	70 lb-in. (8 N·m) All Operating Temperatures
<b>Rotation Range</b>		Maximum Full Stroke: 95° Adjustable Stop: 35° to 95° Maximum Position
<b>Rotation Time for 90 Degrees of Travel</b>	<b>Power On (Running)</b>	150 Seconds Constant for 0 to 70 lb-in (8 N·m) Load, at all Operating Conditions 90 Seconds for 0 to 70 lb-in (8 N·m) Load, in Calibration or Override Mode
	<b>Power Off (Spring Returning)</b>	17 to 25 Seconds for 0 to 70 lb-in. (8 N·m) Load, at Room Temperature 22 Seconds Nominal at Full Rated Load 94 Seconds Maximum with 70 lb-in. (8 N·m) Load, at -40°F (-40°C)
<b>Life Cycles</b>		60,000 Full Stroke Cycles with 70 lb-in. (8 N·m) Load 1,500,000 Repositions with 70 lb-in. (8 N·m) Load
<b>Audible Noise Rating</b>	<b>Power On (Running)</b>	<35 dBA at 70 lb-in. (8 N·m) Load, at a Distance of 39-13/32 in. (1 m)
	<b>Power On (Holding)</b>	<20 dBA at a Distance of 39-13/32 in. (1 m)
	<b>Power Off (Spring Returning)</b>	<52 dBA at 70 lb-in. (8 N·m) Load, at a Distance of 39-13/32 in. (1 m)
<b>Electrical Connections</b>	<b>Models: GGx-3</b>	48 in. (1.2 m) UL 758 Type AWM Halogen Free Cable with 18 AWG (0.85 mm <sup>2</sup> ) Conductors and 0.25 in. (6 mm) Ferrule Ends
	<b>Models: GGA-2</b>	120 in. (3.05 m) UL 444 Type CMP Plenum Rated Cable with 19 AWG (0.75 mm <sup>2</sup> ) Conductors and 0.25 in. (6 mm) Ferrule Ends
	<b>Auxiliary Switches (-xxC Models)</b>	48 in. (1.2 m) UL 758 Type AWM Halogen Free Cable with 18 AWG (0.85 mm <sup>2</sup> ) Conductors and 0.25 in. (6 mm) Ferrule Ends
<b>Conduit Connections</b>		Integral Connectors for 3/8 in. (10 mm) Flexible Metal Conduit

## M9208-GGx-x Series Proportional Electric Spring Return Actuator (Part 2 of 2)

<b>Mechanical Connections</b>	<b>Round Shafts</b>	Range of Sizes: 5/16 to 5/8 in. (8 to 16 mm)
	<b>Square Shafts</b>	Range of Sizes: 1/4 to 1/2 in. (6 to 12 mm)
<b>Enclosure Rating</b>		NEMA 2 (IP54) for all Mounting Directions
<b>Ambient Conditions</b>	<b>Standard Operating</b>	-40 to 140°F (-40 to 60°C); 90% RH Maximum, Noncondensing
	<b>Storage</b>	-40 to 185°F (-40 to 85°C); 95% RH Maximum, Noncondensing
<b>Dimensions</b>		6.33 x 3.90 x 2.26 in. (160.7 x 99 x 57.5 mm)
<b>Compliance</b>  <b>CE</b>	<b>United States</b>	UL Listed, CCN XAPX, File E27734; to UL 60730-1A: 2003-08, Ed. 3.1, Automatic Electrical Controls for Household and Similar Use; and UL 60730-2-14: 2002-02, Ed. 1, Part 2, Particular Requirements for Electric Actuators. (Models: All)
	<b>Canada</b>	UL Listed, CCN XAPX7, File E27734; to UL 60730-1:02-CAN/CSA: July 2002, 3rd Ed., Automatic Electrical Controls for Household and Similar Use; and CSA C22.2 No. 24-93 Temperature Indicating and Regulating Equipment (Models: All).
	<b>Europe</b>	CE Mark – Johnson Controls, Inc., declares that this product is in compliance with the essential requirements and other relevant provisions of the EMC Directive 2004/108/EC and Low Voltage Directive 2006/95/EC.
	<b>Australia and New Zealand</b>	C-Tick Mark, Australia/NZ Emissions Compliant (Models: All)
<b>Shipping Weight</b>		Models: -GGA: 3.43 lb (1.6 kg) Models: -GGC: 3.8 lb (1.7 kg)

*The performance specifications are nominal (unless otherwise noted), and conform to accepted industry standards. For applications which exceed these specifications, consult the local Johnson Controls office. Johnson Controls Inc. shall not be liable for damages resulting from misapplication or misuse of its products.*



**Building Efficiency**

507 E. Michigan Street, Milwaukee, WI 53202

*Metasys® and Johnson Controls® are registered trademarks of Johnson Controls, Inc. All other marks herein are the marks of their respective owners. © 2013 Johnson Controls, Inc.*