

Model AG2401 and AG2401C Secondary Surge Arresters

IMPORTANT SAFETY INSTRUCTIONS • SAVE THESE INSTRUCTIONS

! WARNING *Risk of Electric Shock*

- Thoroughly read instructions before installing unit.
- Installation and Service to be performed by a qualified licensed electrician.
- Intended for indoor or outdoor use.
- Disconnect power before installation.

- All wiring must comply with all applicable electrical codes.
- This unit contains no serviceable parts.
- This product does not protect against direct lightning strikes.

MAINTENANCE:

Inspect every 3 months for cracks in the housing or black soot coming out of nipple end. If either is observed, unit is no longer providing surge protection and it should be replaced.

APPLICATION:

This model is designed specifically for 120 VAC or 120/240 VAC single phase or split phase applications. If your application does not match one of the diagrams shown below, consult the information on the back of this sheet or call your supplier.

120/240 VAC SINGLE PHASE

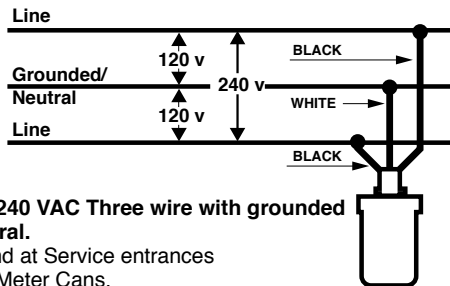

120/240 VAC Three wire with grounded neutral.
Found at Service entrances and Meter Cans.

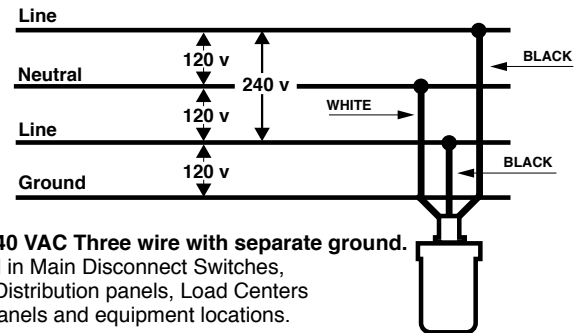

120/240 VAC Three wire with separate ground.
Found in Main Disconnect Switches, Main Distribution panels, Load Centers Sub panels and equipment locations.

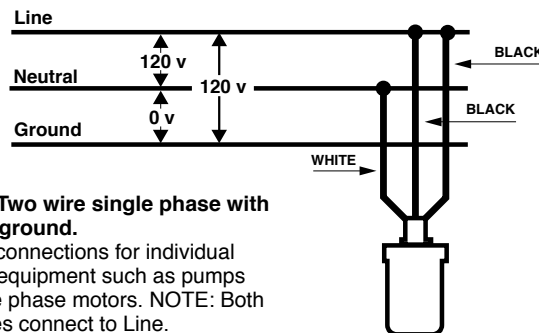

120 VAC Two wire single phase with separate ground.
Found at connections for individual pieces of equipment such as pumps and single phase motors. NOTE: Both Black wires connect to Line.

TWO YEAR LIMITED PRODUCT WARRANTY
For
INTERMATIC SECONDARY SURGE ARRESTOR

(1) What is Covered By This Limited Warranty

Replacement of Product

Intermatic Incorporated ("Intermatic") warrants to the original purchaser only, Intermatic AG 2401 Series Secondary Surge Arrestor (each a "Product") shall be free from defects in material or workmanship for a period of two years (24 months) from date of purchase or 36 months from date of manufacture. If the purchaser discovers a defect in material or workmanship, the purchaser must promptly submit a warranty claim. Upon a determination by Intermatic that the Product is defective, Intermatic, at its sole option shall correct any defect in material or workmanship by replacing the Defective Product at Intermatic's expense. The foregoing remedy is the purchaser's exclusive remedy for a breach of warranty.

The product must be installed in the appropriate application in complete accordance with the installation instructions. All building wiring and other connections to the Product must conform to all applicable national, state, and local electrical codes; the Product must not be opened, modified, exposed to extreme heat or cold, submerged or subjected to abnormal use or service. All products must be used in accordance with the instructions provided with the Product and the purchaser shall be solely responsible for selecting a Product model with specifications appropriate for the equipment to be protected. Intermatic shall determine, in its sole discretion, whether any Product returned by a purchaser has been used in accordance with its instructions, is an appropriate model for the purchaser's use thereof, and whether the Product is defective.

(2) What is Not Covered By This Warranty

Intermatic does not warrant (a) defects in the Product or damage to any equipment caused by the failure to properly install the Product, (b) damage caused by use of the Product for purposes other than those for which it was designed, (c) damage caused by disaster such as fire, flood and wind, (d) damage caused by unauthorized attachments or modification of the Product, (e) damage to the Product occurring during the shipment, (f) electrical disturbances exceeding published product specifications, (g) damage to the Product caused by any other abuse or misuse by the purchaser, or (h) damage due to direct or vicinity lightning strikes. This warranty applies to residential and commercial applications. This device is not intended to provide protection during Utility voltage swells or loss of neutral conditions which are by definition not transient events and are not covered by this warranty.

(3) Disclaimer of Warranty

THE FOREGOING WARRANTIES ARE IN LIEU OF ALL OTHER EXPRESSED WARRANTIES. TO THE EXTENT ALLOWED BY LAW, ANY IMPLIED WARRANTIES OF MERCHANTABILITY OR FITNESS FOR A PARTICULAR PURPOSE ARE LIMITED IN DURATION OF THIS LIMITED WARRANTY.

(4) Limitation of Remedies

IN NO CASE SHALL INTERMATIC BE LIABLE FOR ANY SPECIAL, INCIDENTAL, OR CONSEQUENTIAL DAMAGES BASED UPON BREACH OF WARRANTY, BREACH OF CONTRACT, NEGLIGENCE, STRICT TORT, OR ANY OTHER LEGAL THEORY. SUCH EXCLUDED DAMAGES INCLUDE, BUT ARE NOT LIMITED TO, DAMAGE TO SOFTWARE, LOSS OF DATA, LOSS OF PROFITS, LOSS OF SAVINGS OR REVENUE, LOSS OF USE OF THE PRODUCT OR ANY ASSOCIATED EQUIPMENT, COST OF CAPITAL, COST OF ANY SUBSTITUTE EQUIPMENT, FACILITIES OR SERVICES, DOWNTIME, THE CLAIMS OF THIRD PARTIES INCLUDING CUSTOMERS, DAMAGE TO PROPERTY AND PERSONAL INJURY. SOME STATES DO NOT ALLOW LIMITS ON WARRANTIES OR ON REMEDIES FOR BREACH IN CERTAIN TRANSACTIONS, IN SUCH STATES, THE LIMITS IN THIS PARAGRAPH AND IN PARAGRAPH (3) MAY NOT APPLY.

(5) Time Limit for Bringing Suit

No action arising out of any claimed breach of warranty may be brought more than one year after the cause of action has occurred.

(6) No Other Warranties

Unless modified in writing signed by both parties, this agreement is understood to be the complete and exclusive agreement between the parties, superseding all prior agreements, oral or written, and all other communications between the parties relating to the subject matter of this agreement. No employee of Intermatic or any other party is authorized to make any warranty in addition to those made in this agreement. This warranty is made by: Intermatic Incorporated/After Sales Service, 7777 Winn Rd., Spring Grove, IL. 60081-9698/815-675-7000 <http://www.intermatic.com>