



# DFC2A/H, DFF2A/H

## Product Specifications

### DUCT FREE SPLIT SYSTEM – HIGH WALL

### Efficient 13 SEER Air Conditioners and 7.7 HSPF Heat Pumps

#### 3/4 THRU 3 TONS

- TS Compressor technology for enhanced efficiency in 2, 2½, & 3 ton models
- Rotary compressors in ¾, 1, & 1½ ton models
- “Air Care” advanced purifying technology
- Wireless remote sensor for enhanced functionality
- Programmable for 3 time/temperature settings in 24-hour period
- 30 VDC (¾ – 1½ ton) Indoor units for better safety and savings on installation costs
- Factory charged with R-22 refrigerant
- 1 year No Hassle replacement limited warranty
- 5 year limited compressor, 5 year limited coil and parts warranties



ARI Standard 210/240  
Unitary Heat Pumps



ARI Standard 210/240  
Unitary Air Conditioners



Rated in accordance with ARI Standard 210 and/or 240. Certification applies only when used with proper components as listed with ARI.



see warranty certificate for details

#### Air Conditioners

Outdoor Section	Size (tons)	Dimensions W x H x D (in)
Indoor Section		
DFC2A309J1A	¾	28¾ x 21¼ x 10⅞
DFF2AH09J1A	¾	32⅜ x 10¼ x 7⅞
DFC2A312J1A	1	35⅞ x 25⅜ x 12⅞
DFF2AH12J1A	1	32⅜ x 10¼ x 7⅞
DFC2A318K1A	1½	43⅞ x 25⅜ x 12⅞
DFF2AH18J1A	1½	42½ x 11⅞ x 7⅞
DFC2A324K1A	2	43⅞ x 25⅜ x 12⅞
DFF2AH24K1A	2	42½ x 11⅞ x 7⅞
DFC2A330K1A	2½	44⅞ x 25⅜ x 15¼
DFF2AH30K1A	2½	54⅞ x 12⅜ x 9
DFC2A336K1A	3	44⅞ x 25⅜ x 15¼
DFF2AH36K1A	3	54⅞ x 12⅜ x 9
DFC2A318J2A*	1½	35⅞ x 50⅞ x 12⅞
DFF2AH09J1A*	2 x ¾	32⅜ x 10¼ x 7⅞
DFC2A324J2A*	2	35⅞ x 50⅞ x 12⅞
DFF2AH12J1A*	2 x 1	32⅜ x 10¼ x 7⅞

\* Dual Zone Model

#### Heat Pumps

Outdoor Section	Size (tons)	Dimensions W x H x D (in)
Indoor Section		
DFC2H309J1A	¾	28¾ x 21¼ x 10⅞
DFF2HH09J1A	¾	32⅜ x 10¼ x 7⅞
DFC2H312J1A	1	35⅞ x 25⅜ x 12⅞
DFF2HH12J1A	1	32⅜ x 10¼ x 7⅞
DFC2H318K1A	1½	43⅞ x 25⅜ x 12⅞
DFF2HH18J1A	1½	42½ x 11⅞ x 7⅞
DFC2H324K1A	2	43⅞ x 25⅜ x 12⅞
DFF2HH24K1A	2	42½ x 11⅞ x 7⅞
DFC2H330K1A	2½	44⅞ x 25⅜ x 15¼
DFF2HH30K1A	2½	54⅞ x 12⅜ x 9
DFC2H336K1A	3	44⅞ x 25⅜ x 15¼
DFF2HH36K1A	3	54⅞ x 12⅜ x 9
DFC2H318J2A*	1½	35⅞ x 50⅞ x 12⅞
DFF2HH09J1A*	2 x ¾	32⅜ x 10¼ x 7⅞
DFC2H324J2A*	2	35⅞ x 50⅞ x 12⅞
DFF2HH12J1A*	2 x 1	32⅜ x 10¼ x 7⅞

\* Dual Zone Model

**Required CLEARANCES, Outdoor**

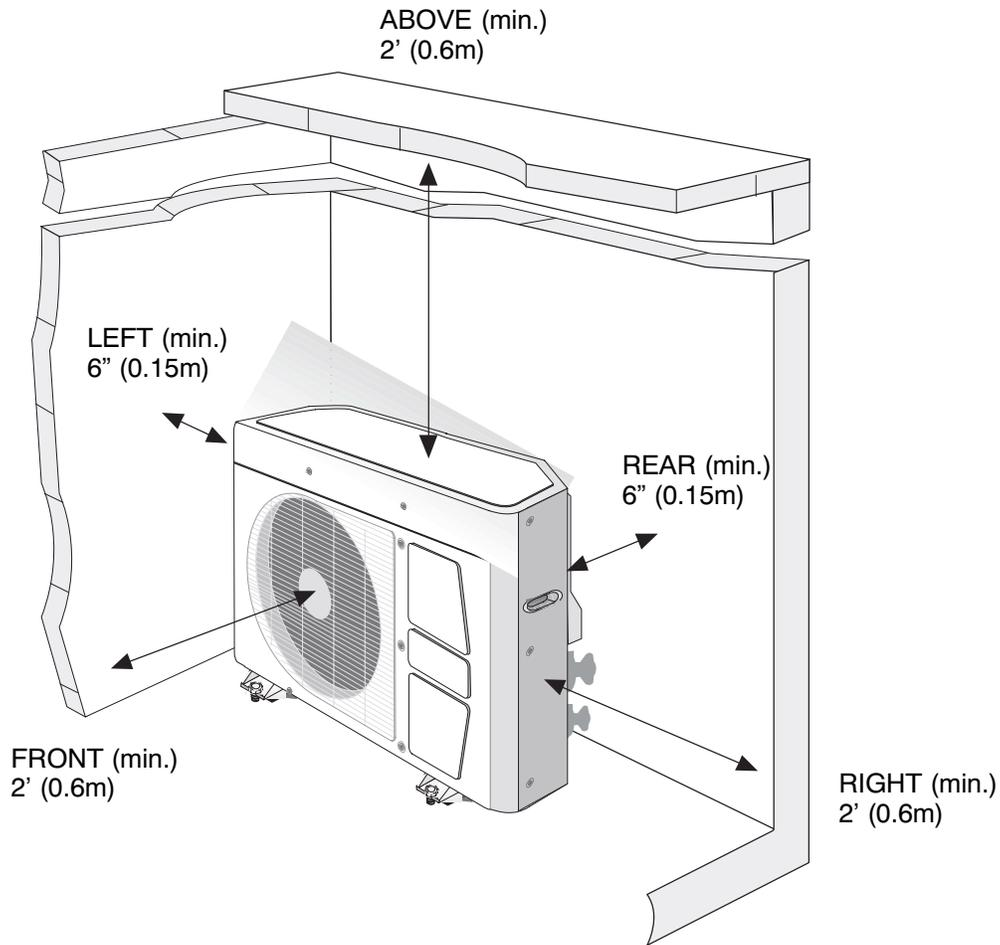

**Required CLEARANCES, Indoor**

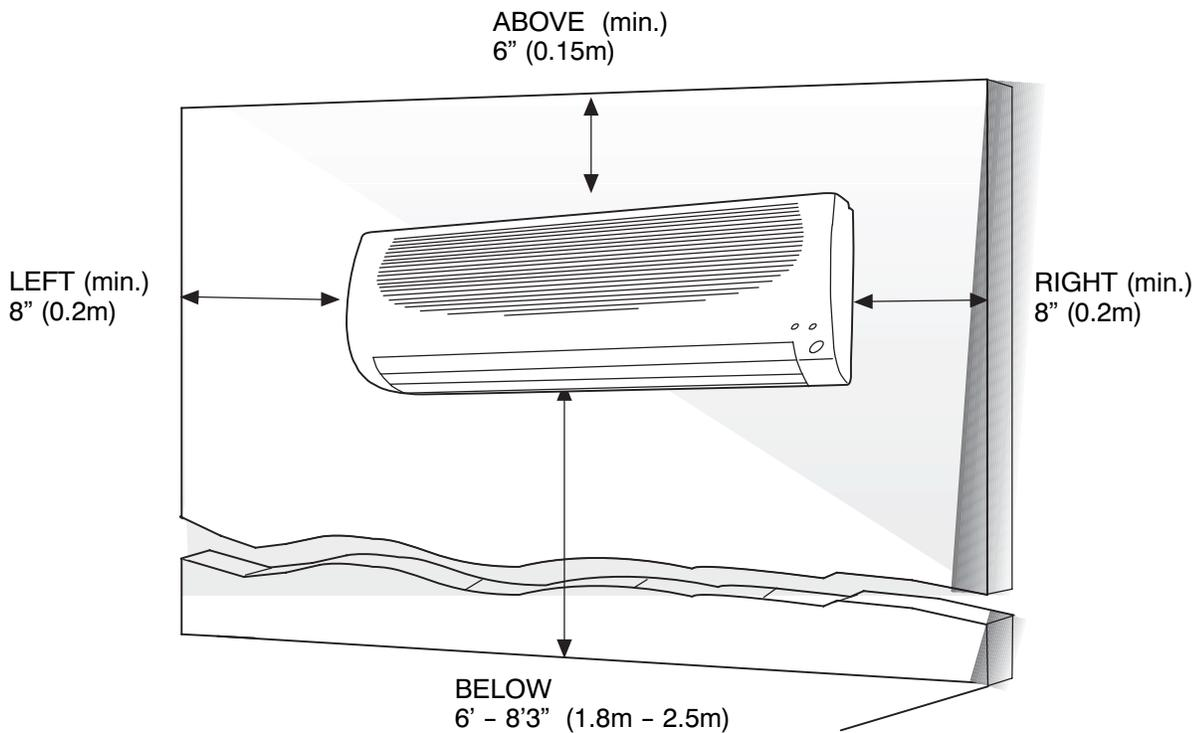

Outdoor Model Size	09J1A	12J1A	18K1A	24K1A	30K1A	36K1A	18J2A	24J2A
Indoor Model Size	09J1A	12J1A	18J1A	24K1A	30K1A	36K1A	2 x 09J1A	2 x 12J1A
<b>PHYSICAL DATA – Air Conditioner</b>								
Cooling Capacity (BTU/hr)	9,000	11,600	19,000	22,800	29,000	33,000	2 x 9,000	2 x 11,600
SEER	13.0	13.0	13.0	13.0	14.0	13.0	13.0	13.0
Moisture Removal (pints/hr)	2.6	4.5	5.3	5.0	7.0	8.0	2 x 2.6	2 x 4.5
Indoor Fan CFM (High speed)	350	400	670	726	860	860	2 x 350	2 x 400
Indoor Sound Rating (dBA High – dBA Low)	55 – 45	60 – 48	62 – 50	64 – 50	65 – 53	65 – 53	2 x 55-45	2 x 60-48
Outdoor Sound Rating (dBA)	68	72	74	76	76	76	74	76
Liquid Line Connection Size – Flare (in.)	1/4	1/4	3/8	3/8	3/8	3/8	2 x 1/4	2 x 1/4
Vapor Line Connection Size – Flare (in.)	1/2	1/2	5/8	5/8	3/4	3/4	2 x 1/2	2 x 1/2
Maximum Vertical Separation (ft.) <b>Indoor Higher</b> than Outdoor	30	30	30	65	65	65	30	30
Maximum Vertical Separation (ft.) <b>Indoor Lower</b> than Outdoor	30	30	30	75	75	75	30	30
Maximum Line-set Length (ft.)	50	50	50	130	130	130	50	50
Factory Charge R-22 (lbs.) *	2.7	3.1	4.1	4.2	6.06	5.9	2 x 2.7	2 x 3.1
* Units are factory charged for 25' of line set. Add or remove 0.3 oz. of charge per foot if line set length is different.								
Net Weight, Outdoor (lbs.)	73	114	136	187	198	198	136	228
Net Weight, Indoor (lbs.)	19	19	27.5	27.5	51	51	2 x 19	2 x 19
<b>OUTDOOR ELECTRICAL DATA – Air Conditioner</b>								
Required Supply Voltage	115-1-60 AC		208/230-1-60 AC				115-1-60 AC	
Control Voltage	30 VDC			24 VAC				
Minimum Circuit Ampacity – <b>MCA</b> (amps)	9.0	11.6	10.7	11.0	13.7	17.7	19.8	24.6
Maximum OverCurrent Protective device – <b>MOCP</b> (amps)	15	20	20	20	20	30	25	30
Compressor <b>RLA</b> (Rated Load Amps) <b>LRA</b> (Locked Rotor Amps)	6.1 42	7.6 58	6.5 42	8.6 60	10.0 76	12.9 73	7.2 42	9.3 58
Fan Motor Amps	0.90	1.00	0.88	0.87	0.94	0.94	1.00	1.00
<b>INDOOR ELECTRICAL DATA – Air Conditioner</b>								
Required Supply Voltage	30 DC <sup>1</sup>			208/230-1-60 AC			30 DC <sup>1</sup>	
Control Voltage	30 VDC			24 VAC				
<b>FLA</b> (Full Load Amps)	1.8	1.8	2.4	0.6	0.6	0.6	2 x 1.8	2 x 1.8
Minimum Circuit Ampacity – <b>MCA</b> (amps)	N/A <sup>1</sup>	N/A <sup>1</sup>	N/A <sup>1</sup>	0.46	0.55	0.55	N/A <sup>1</sup>	N/A <sup>1</sup>
Maximum OverCurrent Protective device – <b>MOCP</b> (amps)	N/A <sup>1</sup>	N/A <sup>1</sup>	N/A <sup>1</sup>	15 <sup>2</sup>	15 <sup>2</sup>	15 <sup>2</sup>	N/A <sup>1</sup>	N/A <sup>1</sup>

1. 30VDC is generated by the outdoor unit and delivered through low voltage wiring to power the indoor unit. Separate disconnect or over-current protection device not required at indoor unit.

2. If indoor unit is powered from outdoor terminal block, the MOCP for the outdoor unit covers both units.

Outdoor Model Size	09J1A	12J1A	18K1A	24K1A	30K1A	36K1A	18J2A	24J2A
Indoor Model Size	09J1A	12J1A	18J1A	24K1A	30K1A	36K1A	2 x 09J1A	2 x 12J1A
<b>PHYSICAL DATA – Heat Pump</b>								
Cooling Capacity (BTU/hr)	9,000	11,600	19,000	22,800	29,000	33,000	2 x 9,000	2 x 11,600
SEER	13.0	13.0	13.0	13.0	14.0	13.0	13.0	13.0
Heating Capacity (BTU/hr)	8,600	11,800	18,300	22,600	28,000	32,000	2 x 8,600	2 x 11,800
HSPF	7.7	7.7	7.7	7.7	8.4	8.4	7.7	7.7
Moisture Removal (pints/hr)	2.6	4.5	5.3	5.0	7.0	8.0	2 x 2.6	2 x 4.5
Indoor Fan CFM (High speed)	350	400	670	726	860	860	2 x 350	2 x 400
Indoor Sound Rating (dBA High – dBA Low)	55 – 45	60 – 48	62 – 50	64 – 50	65 – 53	65 – 53	2 x 55-45	2 x 60-48
Outdoor Sound Rating (dBA)	68	72	74	76	76	76	74	76
Liquid Line Connection Size – Flare (in.)	1/4	1/4	3/8	3/8	3/8	3/8	2 x 1/4	2 x 1/4
Vapor Line Connection Size – Flare (in.)	1/2	1/2	5/8	5/8	3/4	3/4	2 x 1/2	2 x 1/2
Maximum Vertical Separation (ft.) <b>Indoor Higher</b> than Outdoor	30	30	30	65	65	65	30	30
Maximum Vertical Separation (ft.) <b>Indoor Lower</b> than Outdoor	30	30	30	75	75	75	30	30
Maximum Line-set Length (ft.)	50	50	50	130	130	130	50	50
Factory Charge R-22 (lbs.) *	2.7	3.1	4.1	4.2	6.06	5.9	2 x 2.7	2 x 3.1
* Units are factory charged for 25' of line set. Add or remove 0.3 oz. of charge per foot if line set length is different.								
Net Weight, Outdoor (lbs.)	73	114	136	187	198	198	136	228
Net Weight, Indoor (lbs.)	19	19	27.5	27.5	51	51	2 x 19	2 x 19
<b>OUTDOOR ELECTRICAL DATA – Heat Pump</b>								
Required Supply Voltage	115-1-60 AC		208/230-1-60 AC				115-1-60 AC	
Control Voltage	30 VDC			24 VAC				
Minimum Circuit Ampacity – <b>MCA</b> (amps)	9.0	11.6	10.7	11.0	13.7	17.7	19.8	24.6
Maximum OverCurrent Protective device – <b>MOCP</b> (amps)	15	20	20	20	20	30	25	30
Compressor <b>RLA</b> (Rated Load Amps) <b>LRA</b> (Locked Rotor Amps)	6.1 42	7.6 58	6.5 42	8.6 60	10.0 76	12.9 73	7.2 42	9.3 58
Fan Motor Amps	0.90	1.00	0.88	0.87	0.94	0.94	1.00	1.00
<b>INDOOR ELECTRICAL DATA – Heat Pump</b>								
Required Supply Voltage	30 DC <sup>1</sup>			208/230-1-60 AC			30 DC <sup>1</sup>	
Control Voltage	30 VDC			24 VAC				
<b>FLA</b> (Full Load Amps)	1.8	1.8	2.4	0.6	0.6	0.6	2 x 1.8	2 x 1.8
Minimum Circuit Ampacity – <b>MCA</b> (amps)	N/A <sup>1</sup>	N/A <sup>1</sup>	N/A <sup>1</sup>	0.46	0.55	0.55	N/A <sup>1</sup>	N/A <sup>1</sup>
Maximum OverCurrent Protective device – <b>MOCP</b> (amps)	N/A <sup>1</sup>	N/A <sup>1</sup>	N/A <sup>1</sup>	15 <sup>2</sup>	15 <sup>2</sup>	15 <sup>2</sup>	N/A <sup>1</sup>	N/A <sup>1</sup>

- 30VDC is generated by the outdoor unit and delivered through low voltage wiring to power the indoor unit. Separate disconnect or over-current protection device not required at indoor unit.
- If indoor unit is powered from outdoor terminal block, the MOCP for the outdoor unit covers both units.

<b>ACCESSORIES</b>		
<b>Part Number</b>	<b>Description</b>	<b>Used On Model Size</b>
NADA001DK	Condensate Pump	9, 12, 2 x 9, 2 x 12
NADA002DK	Condensate Pump	18, 24
NADA003DK	Condensate Pump	30, 36
NADA001LA	Low Ambient Kit *	ALL
NADA001CH	Crankcase Heater (120V)	9, 12, 2 x 9, 2 x 12
NADA002CH	Crankcase Heater (240V)	18, 24, 30, 36
1173540	Isolation Relay (120V) *	9, 12, 2 x 9, 2 x 12
1174662	Isolation Relay (240V) *	18, 24, 30, 36
NADA001TW	Wired Control	ALL

\* When Low Ambient Kit is used with Heat Pump, additional Isolation Relay is required.

DUCT FREE SPLIT SYSTEM MODEL NUMBER IDENTIFICATION GUIDE – OUTDOOR									
	<b>DFC</b>	<b>2</b>	<b>A</b>	<b>3</b>	<b>09</b>	<b>J</b>	<b>1</b>	<b>A</b>	<b>1</b>
DFC = Duct Free Condenser									
2 = R-22									
4 = Environmentally Sound R-410A <b>REFRIGERANT</b>									
A = Air Conditioner									
H = Heat Pump									
<b>TYPE</b>									
3 = 13									
4 = 14									
<b>NAMEPLATE SEER</b>									
09 = 9,000 BTUH = ¾ ton									
12 = 12,000 BTUH = 1 ton									
18 = 18,000 BTUH = 1½ tons									
24 = 24,000 BTUH = 2 tons									
30 = 30,000 BTUH = 2½ tons									
36 = 36,000 BTUH = 3 tons									
<b>NOMINAL CAPACITY</b>									
J = 115-1-60									
K = 208/230-1-60									
<b>SUPPLY VOLTAGE</b>									
1 = Single Zone									
2 = Dual Zone									
3 = Tri Zone									
<b>SALES CODE / FEATURES</b>									
Sales Code									
Engineering Revision									

DUCT FREE SPLIT SYSTEM MODEL NUMBER IDENTIFICATION GUIDE – INDOOR									
	<b>DFF</b>	<b>2</b>	<b>A</b>	<b>H</b>	<b>09</b>	<b>J</b>	<b>1</b>	<b>A</b>	<b>1</b>
DFF = Duct Free Fan Coil									
2 = R-22									
4 = Environmentally Sound R-410A <b>REFRIGERANT</b>									
A = Air Conditioner									
H = Heat Pump									
<b>TYPE</b>									
H = High Wall									
U = Under Ceiling									
C = Cassette									
<b>APPLICATION</b>									
09 = 9,000 BTUH = ¾ ton									
12 = 12,000 BTUH = 1 ton									
18 = 18,000 BTUH = 1½ tons									
24 = 24,000 BTUH = 2 tons									
30 = 30,000 BTUH = 2½ tons									
36 = 36,000 BTUH = 3 tons									
<b>NOMINAL CAPACITY</b>									
J = 115-1-60									
K = 208/230-1-60									
<b>SUPPLY VOLTAGE</b>									
1 = Single Zone									
2 = Dual Zone									
3 = Tri Zone									
<b>SALES CODE / FEATURES</b>									
Sales Code									
Engineering Revision									