

STANDARD CONSTRUCTION
FRAME:

COLD ROLLED DQSK STEEL
NOMINAL WALL THICKNESS OF 0.026"

OPTIONS:

FACTORY OR FIELD INSTALLED BUTTERFLY DAMPER (BCD)
FACTORY OR FIELD INSTALLED OPPOSED BLADE DAMPER (OBR)
AUXILIARY MOUNTING FRAME, FOR GYPSUM BOARD (SMA)
INSULATED BACKPAN (SCFI)
FOURTH CONE ACCESSORY AVAILABLE
2" EXTENSION COLLAR INCLUDED AS AN ALTERNATIVE METHOD TO ACCOMMODATE JOB CONDITIONS (MUST BE MECHANICALLY FASTENED BY INSTALLER)

FEATURES:

HEAVY GAUGE STEEL PROVIDES SUPERIOR DURABILITY.
STANDARD 3 CONE DESIGN PROVIDES ARCHITECTURAL FLEXIBILITY.
SUPPLIES AIR IN A 360 DEGREE PATTERN.
AVAILABLE LAY-IN FRAME STYLE.

FINISH:

SKY WHITE (STANDARD)

AXALTA SKY-WHITE POLYESTER POWDER COATING GIVES AN ATTRACTIVE BRIGHT WHITE FINISH AND PROVIDES ADDITIONAL PROTECTION FROM AGING AND WEAR.

SIZES AVAILABLE:

MODEL	DIMENSIONS	NECK DIAMETER
SCF06	24" X 24"	6"
SCF08	24" X 24"	8"
SCF10	24" X 24"	10"
SCF12	24" X 24"	12"
SCF14	24" X 24"	14"

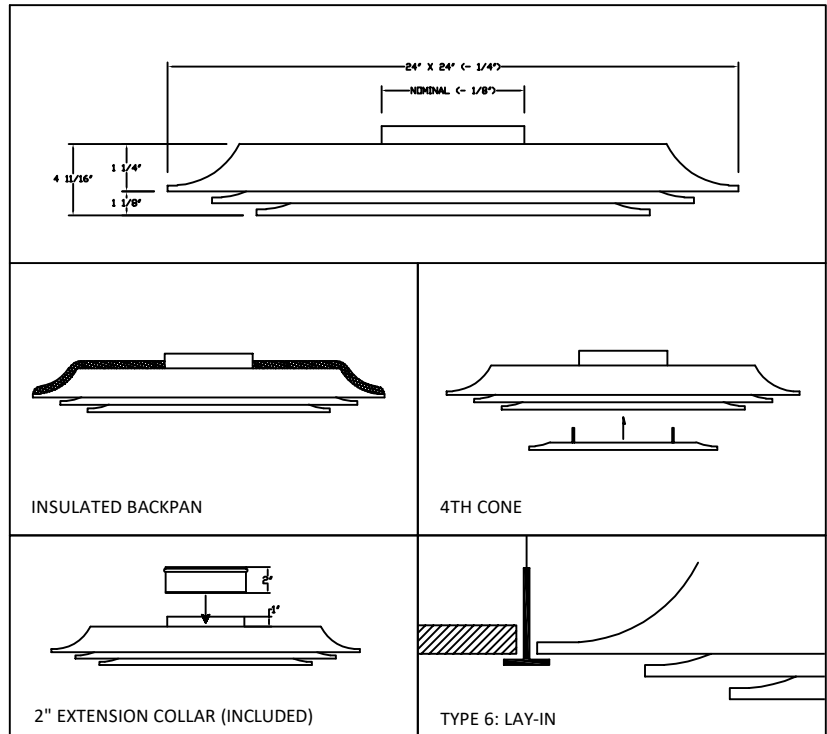
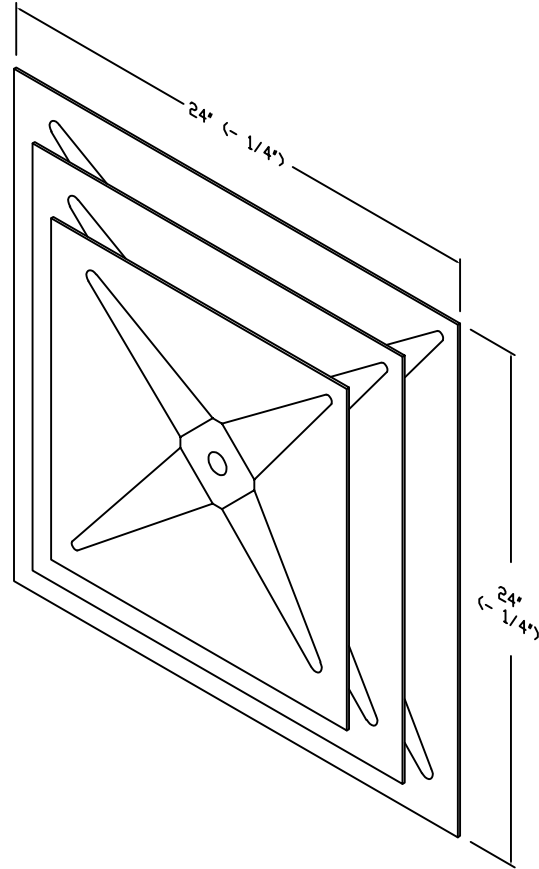

JOB NAME:
LOCATION:
ARCHITECT:
ENGINEER:
CONTRACTOR:
CONTACT GRILLE TECH INC. FOR ADDITIONAL INFORMATION OR WITH SPECIAL REQUIREMENTS.
5101 NW 36TH AVE MIAMI, FL 33142 PHONE: 305-537-0053 FAX: 305-537-0064
WEB: WWW.GRILLETECHINC.COM EMAIL: SALES@GRILLETECHINC.COM

SCF

SQUARE FACE/ROUND NECK CEILING DIFFUSER
PRODUCT SPECIFICATIONS

NOTE: ALL DRAWINGS SUBJECT TO CHANGE WITHOUT PRIOR NOTICE.