

**Submission Data: 9RFLW1
Inverter Driven Heat Pump**

9,000 BTU Wall Mount

Job Name: _____

Date: _____

Location: _____

Approval: _____

Engineer: _____

Construction: _____

Submitted to: _____

Unit #: _____

Submitted by: _____

Drawing #: _____

Reference: _____

General Features

- Wired or wireless remote control
- Apple catchin filter
- Ion deodorizing filter
- Auto louver: up/down
- Auto louver: 4-way
- Low ambient cooling
- Cold prevention
- Sleep timer
- 24-hour timer
- Dry mode
- Standard Warranty: 5 years parts, 7 years compressor. Applies to systems purchased before June 1st 2015*
- Extended Warranty: 10 years parts, 10 years compressor. Systems that have been installed on or after June 1st 2015 by licensed contractors and the online Product Registration has been submitted.**
- Elite Contractor Extended Warranty: 12 years parts, 12 years compressor. Systems that have been installed on or after June 1st 2015 by contractors who have met requirements and have been approved for elite contractor status plus, the online Product Registration has been submitted.***

Model Information

Condenser..... AOU9RFLW1
Evaporator..... ASU9RFLW1

Electrical..... 208/230 V AC 1ph-60HZ
Available Voltage Range..... 187 - 253 V +/- 10%
Max Fuse Size..... 15 A
Max Operating Current

Condenser..... 0.4 A
Evaporator..... 4.2 A
Input Power
Cooling..... 0.65 kW
Heating..... 0.89 kW
Running Current
Cooling..... 3.2 A
Heating..... 4.2 A

Capacity
Nominal Cooling..... 9,000 Btu/h
Min-Max Cooling..... 1,700 – 10,900 Btu/h
Nominal Heating..... 12,000 Btu/h
Min-Max Heating..... 1,700 – 15,000 Btu/h

Compressor..... Rotary x1
Motor Output..... 500 W
Refrigerant..... R410a
Charge..... 1 lbs. 14 oz.
Oil..... RB68

Fan Motor
Type: DC (condenser)..... Propeller x1
Type: DC (evaporator)..... Cross flow fan x1
Motor Output (condenser)..... 23 W
Motor Output (evaporator)..... 30 W

Heat Exchanger
Condenser
(H x W x D) in. (mm)..... 19-13/16 x 25-1/4 x 1-7/16 (504x642x36.4)
Fin Pitch..... 18 FPI
Rows x Stages..... 2 x 24
Pipe Type (Material)..... Grooved H-Pin (Copper)
Type (Material)..... Corrugate (Aluminum)

Note: Specifications are based on the following conditions.
Cooling: Indoor temperature of 80°F (26.7°C) DB/67°F (19.44°C) WB, and outdoor temperature of 95°F (35°C) DB/75°F (23.9°C) WB.
Heating: Indoor temperature of 70°F (21.1°C) DB/59°F (15°C) WB, and outdoor temperature of 47°F (8.33°C) DB/43°F (6.11°C) WB.
Pipe length: 24ft. 7in. (7.5m), Height difference: 0ft. (0m) (Outdoor unit – indoor unit)
(*Standard warranty / **10 year warranty / ***12 year warranty)



Operation Temperature Range

Cooling..... 15°F to 115°F (-10°C - 46°C)
Heating..... 5°F to 75°F (-15°C - 24°C)

Efficiency

SEER..... 23.0
EER (cooling)..... 13.8
COP (heating)..... 13.50
HSPF (heating)..... 11.0

Enclosure

Material
Evaporator..... Polystyrene
Condenser..... Painted galvanized steel
Color
Condenser..... Beige (10 YR 7.5/1.0 NN)
Evaporator..... White

Sound Pressure Level

Condenser (max)..... 48 dB(A)
Evaporator (max)..... 43 dB(A)

Dimensions

H x W x D
Condenser in. (mm)..... 21-1/4 x 26 x 11-7/16in. (540x660x290)
Evaporator in. (mm)..... 10-9/16 x 33-1/16 x 8 (268x840x203)

Connection Pipe

Liquid..... Ø1/4 in. (Ø6.35 mm)
Gas..... Ø3/8 in. (Ø9.52 mm)
Method (Liquid/Gas)..... Flare
Max Length {(Pre-charge)}..... 66 ft. (20 m) {(49 ft.) (15 m)}
Max Height Difference..... 49 ft. (15 m)

Weight

Condenser..... 60 lbs. (27 kg)
Evaporator..... 19 lbs. (8.5 kg)

Accessories

UTY-RNNUM^{^1}..... Wired remote control
UTY-RVNUM^{^1}..... Wired remote control (backlit, shows room temp.)
UTY-RSNUM^{^1}..... Wired remote control (simple)
UTY-XWZZZ5..... Dry contact wire kit
^{^1} Requires interface kit # UTY-XCBXZ2 in order to connect these devices to them.



Dimensions: 9RLFW1

[Unit: in. (mm)]

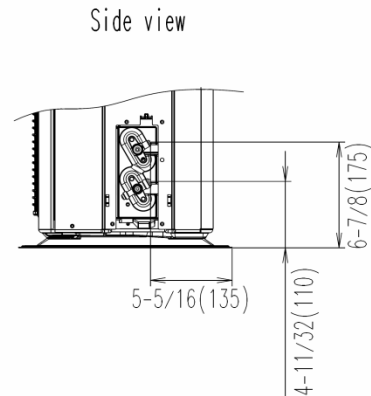
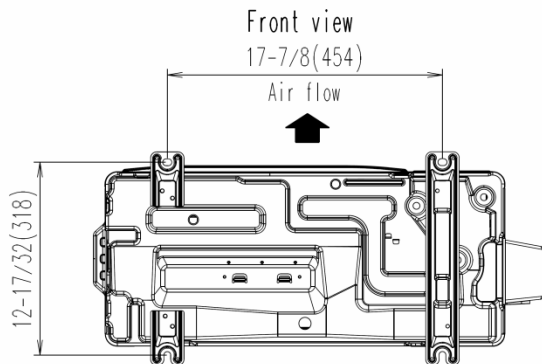
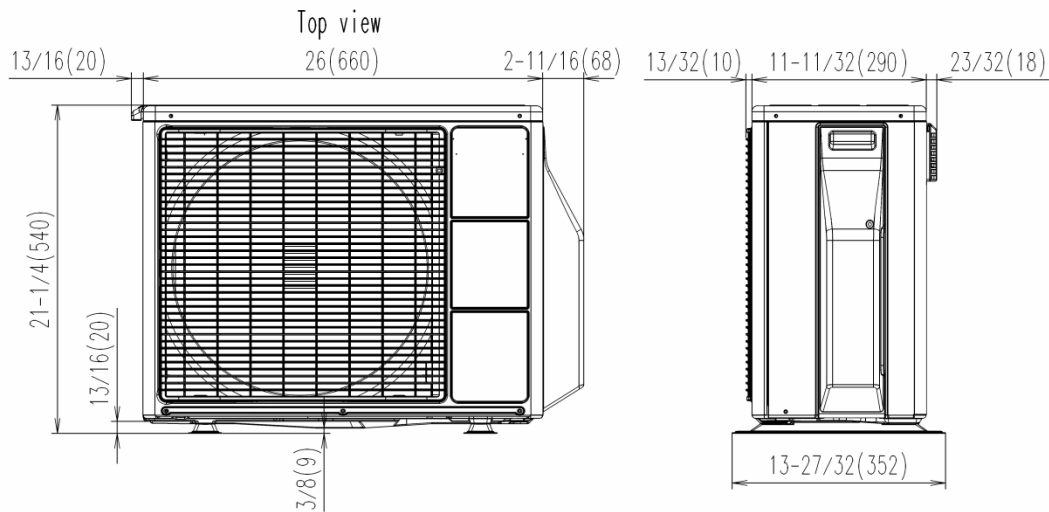
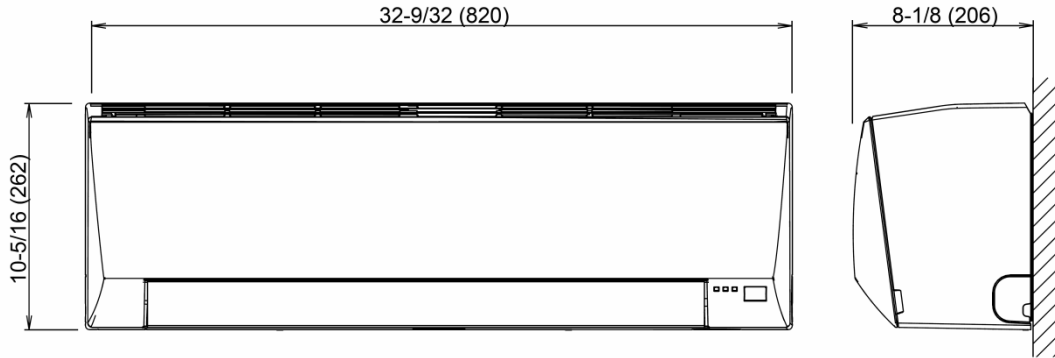

Bottom view

Side view