

Split type air conditioner  
Cassette type (60Hz)

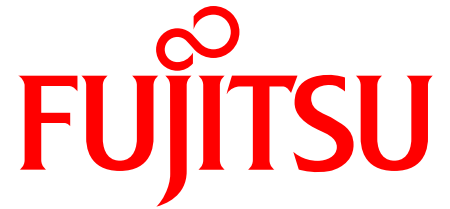

# SERVICE MANUAL



Indoor unit	Outdoor unit
AUU18RGLX	AOU18RGLX
AUU24RGLX	AOU24RGLX
AUU30RGLX	AOU30RGLX
AUU36RGLX	AOU36RGLX
AUU42RGLX	AOU42RGLX
AUU48RGLX	AOU48RGLX
UTG-GCGF	

## CONTENTS

SPECIFICATIONS.....	1
DIMENSIONS.....	7
REFRIGERANT CIRCUIT.....	11
PCB CIRCUIT DIAGRAM.....	13
ERROR CODE.....	17
PARTS (DECORATION PANEL).....	19
PARTS (INDOOR UNIT).....	21
PARTS (OUTDOOR UNIT).....	26
ACCESSORIES.....	33

# Specifications

Type				Cassette			
				Inverter heat pump			
Model name				AUU18RGLX	AUU24RGLX		
Power supply				208/230 V – 60 Hz			
Power supply intake				Outdoor unit			
Available voltage range				187–253 V			
Capacity	Cooling	Rated	kW	5.28	7.03		
		Min.—Max.	Btu/h	18,000	24,000		
			kW	1.58–6.30	1.58–8.50		
	Heating	Rated	kW	6.15	7.91		
		Min.—Max.	Btu/h	21,000	27,000		
			kW	1.58–7.50	1.58–9.50		
Input power	Cooling	Rated	kW	1.35	1.88		
		Min.—Max.	kW	0.50–2.05	0.58–2.77		
		Rated	kW	1.47	2.15		
	Heating	Min.—Max.	kW	0.48–2.27	0.50–2.88		
		Fan	HIGH	W	16	21	
			MED	W	12	16	
	LOW		W	11	13		
	QUIET		W	7	9		
	Current	Cooling	Rated	A	6.1	8.4	
		Heating	Rated	A	6.6	9.6	
	EER	Cooling	kW/kW		3.93	3.75	
			Btu/hW		13.4	12.8	
COP	Heating	kW/kW		4.19	3.69		
		Btu/hW		14.3	12.6		
SEER				21.4	20.0		
HSPF				10.9	10.8		
Power factor	Cooling		%	97			
	Heating		%	97			
Moisture removal			pints/h (L/h)	3.9 (2.2)	5.1 (2.9)		
Maximum operating current *1	Cooling		A	13.6	15.6		
	Heating		A	14.1	16.1		
Fan	Airflow rate	Cooling	HIGH	CFM (m <sup>3</sup> /h)	618 (1,050)	677 (1,150)	
			MED	565 (960)	618 (1,050)		
			LOW	530 (900)	577 (980)		
			QUIET	459 (780)	512 (870)		
		Heating	HIGH	618 (1,050)	677 (1,150)		
			MED	565 (960)	618 (1,050)		
			LOW	530 (900)	577 (980)		
			QUIET	459 (780)	512 (870)		
	Type x Q'ty			Turbo fan x 1			
	Motor output			W			
Sound pressure level *2	Cooling	HIGH	dB (A)	33	35		
		MED	32	34			
		LOW	31	32			
		QUIET	28	29			
	Heating	HIGH	33	35			
		MED	32	34			
		LOW	31	32			
		QUIET	28	29			
		Heat exchanger type				8-9/32 x 83-3/4 x 17/32 (210 x 2,127 x 13.3)	
		Dimensions (H x W x D)				in (mm)	
Fin pitch				FPI			
Rows x Stages				21			
Pipe type				2 x 10			
Fin type				Copper tube			
				Aluminum			
Dimensions (H x W x D)	Net			9-11/16 x 33-1/16 x 33-1/16 (246 x 840 x 840)			
	Gross			11-3/4 x 37-13/16 x 37-3/8 (298 x 960 x 950)			
Weight	Net			53 (24)			
	Gross			62 (28)			
Connection pipe	Size	Liquid	in (mm)	Ø 1/4 (6.35)	Ø 3/8 (9.52)		
		Gas	in (mm)	Ø 1/2 (12.70)	Ø 5/8 (15.88)		
Method		Flare					
Drain hose	Material	PVC (VP25)					
	Size			in (mm)			
				Ø 1 (25) (I.D.), Ø 1-1/16 (26.6) (O.D.)			
Operation range	Cooling			°F (°C)			
				64 to 90 (18 to 32)			
				%RH			
				80 or less			
				°F (°C)			
				60 to 86 (16 to 30)			
Cassette grille (Option)	Material		PS				
	Color	UTG-GCGF		White			
		UTG-LCGVCB		Approximate color of Munsell N 9.25/ Black			
	Dimensions (H x W x D)	Net			2-1/16 x 37-3/8 x 37-3/8 (53 x 950 x 950)		
		Gross			4-5/16 x 39-3/8 x 39-3/4 (110 x 1,000 x 1,010)		
	Weight	Net			13 (6.0)		
Gross				22 (10)			

Type	Cassette	
	Inverter heat pump	
Model name	AUU18RGLX	AUU24RGLX
<p><b>NOTES:</b></p> <ul style="list-style-type: none"> <li>• Specifications are based on the following conditions: <ul style="list-style-type: none"> <li>– Cooling: Indoor temperature of 80 °FDB (26.67 °CDB) / 67 °FWB (19.44 °CWB), and outdoor temperature of 95 °FDB (35 °CDB) / 75 °FWB (23.9 °CWB).</li> <li>– Heating: Indoor temperature of 70 °FDB (21.11 °CDB) / 59 °FWB (15 °CWB), and outdoor temperature of 47 °FDB (8.33 °CDB) / 43 °FWB (6.11 °CWB).</li> <li>– Pipe length: 24 ft 6 in (7.5 m), Height difference: 0 ft (0 m). (Between outdoor unit and indoor unit.)</li> </ul> </li> <li>• Protective function might work when using it outside the operation range.</li> <li>• *1: Maximum operating current is the total current of the indoor unit and the outdoor unit.</li> <li>• *2: Sound pressure level <ul style="list-style-type: none"> <li>– Measured values in manufacturer's anechoic chamber.</li> <li>– Because of the surrounding sound environment, the sound levels measured in actual installation conditions might be higher than the specified values here.</li> </ul> </li> </ul>		

Type				Cassette					
				Inverter heat pump					
Model name				AUU30RGLX	AUU36RGLX	AUU42RGLX	AUU48RGLX		
Power supply				208/230 V ~ 60 Hz					
Power supply intake				Outdoor unit					
Available voltage range				187—253 V					
Capacity	Cooling	Rated	kW	8.79	10.55	12.31	14.07		
			Btu/h	30,000	36,000	42,000	48,000		
		Min.—Max.	kW	2.81—10.26	2.81—11.43	5.01—13.19	5.01—14.65		
	Heating		Btu/h	9,600—35,000	9,600—39,000	17,100—45,000	17,100—50,000		
		Rated	kW	9.38	10.55	13.77	15.53		
		Min.—Max.	kW	2.70—11.43	2.70—14.07	5.28—14.95	5.28—16.12		
		Btu/h	9,200—39,000	9,200—48,000	18,000—51,000	18,000—55,000			
Input power	Cooling	Rated	kW	2.57	3.60	3.72	4.75		
		Min.—Max.		0.60—3.33	0.60—3.94	0.63—4.35	0.63—4.91		
	Heating	Rated	2.38	2.73	3.74	4.49			
		Min.—Max.	0.52—3.27	0.52—4.19	0.55—4.39	0.55—4.67			
	Fan	HIGH	W	52	87	106	129		
		MED		39	52	60	95		
		LOW		31	39	45	55		
		QUIET		20	23	30	34		
	Current	Cooling	Rated	A	11.5	16.1	16.7	20.9	
		Heating			10.7	12.2	16.8	19.7	
Power factor	Cooling			97					
	Heating			97					
EER	Cooling			kW/kW	3.43	2.93	3.31	2.96	
				Btu/hW	11.7	10.0	11.3	10.1	
COP	Heating			kW/kW	3.96	3.87	3.69	3.46	
				Btu/hW	13.5	13.2	12.6	11.8	
SEER					Btu/hW	18.6	17.5	18.5	
HSPF						11.5	11.2	9.7	
Moisture removal					pints/h (L/h)	5.3 (3.0)	6.5 (3.7)	7.7 (4.4)	9.3 (5.3)
Maximum operating current *1	Cooling			A	15.6	17.6	19.7	22.2	
	Heating				16.1	19.1	19.7	20.7	
Fan	Airflow rate	Cooling	CFM (m <sup>3</sup> /h)	HIGH	942 (1,600)	1,118 (1,900)	1,177 (2,000)	1,236 (2,100)	
				MED	824 (1,400)	936 (1,590)	971 (1,650)	1,048 (1,780)	
				LOW	748 (1,270)	836 (1,420)	859 (1,460)	942 (1,600)	
				QUIET	677 (1,150)	695 (1,180)	765 (1,300)	777 (1,320)	
		Heating	HIGH	942 (1,600)	1,118 (1,900)	1,177 (2,000)	1,236 (2,100)		
			MED	824 (1,400)	936 (1,590)	971 (1,650)	1,048 (1,780)		
			LOW	748 (1,270)	836 (1,420)	859 (1,460)	942 (1,600)		
			QUIET	677 (1,150)	695 (1,180)	765 (1,300)	777 (1,320)		
	Type x Q'ty			Turbo fan x 1					
	Motor output			W					
Sound pressure level *2	Cooling	HIGH	dB (A)	40	44	46	47		
				MED	38	41	42	43	
				LOW	36	38	39	40	
				QUIET	33	34	35	36	
		Heating	HIGH	40	44	46	47		
			MED	38	41	42	43		
			LOW	36	38	39	40		
			QUIET	33	34	35	36		
	Heat exchanger type	Dimensions (H x W x D)		in (mm)	9-29/32 x 83-3/4 x 17/32 (252 x 2,127 x 13.3)		9-29/32 x 83-7/8 x 17/32 (252 x 2,131 x 13.3)		
		9-29/32 x 83-5/32 x 17/32 (252 x 2,061 x 13.3)			9-29/32 x 81-3/16 x 17/32 (252 x 2,062 x 13.3)		9-29/32 x 78-11/16 x 17/32 (252 x 1,999 x 13.3)		
Fin pitch		FPI	21						
Rows x Stages			2 x 12		3 x 12				
Pipe type			Copper tube						
Fin type			Aluminum						
Dimensions (H x W x D)	Net			11-5/16 x 33-1/16 x 33-1/16 (288 x 840 x 840)					
	Gross			13-3/8 x 37-13/16 x 37-3/8 (340 x 960 x 950)					
Weight	Net			57 (26)		64 (29)			
	Gross			66 (30)		73 (33)			
Connection pipe	Size	Liquid			Ø 3/8 (9.52)				
		Gas			Ø 5/8 (15.88)				
Drain hose	Method			Flare					
	Material			PVC (VP25)					
Operation range	Cooling			°F (°C)					
				64 to 90 (18 to 32)					
Cassette grille (Option)	Material			°RH					
				80 or less					
Color	UTG-GCGF			°F (°C)					
				60 to 86 (16 to 30)					
Dimensions (H x W x D)	Net			PS					
				White					
Weight	Gross			Approximate color of Munsell N 9.25/					
				Black					
Dimensions (H x W x D)	Net			Approximate color of Munsell N 2					
				2-1/16 x 37-3/8 x 37-3/8 (53 x 950 x 950)					
Weight	Gross			4-5/16 x 39-3/8 x 39-3/4 (110 x 1,000 x 1,010)					
				13 (6.0)					
				22 (10)					

Type	Cassette			
	Inverter heat pump			
Model name	AUU30RGLX	AUU36RGLX	AUU42RGLX	AUU48RGLX
<p><b>NOTES:</b></p> <ul style="list-style-type: none"> <li>• Specifications are based on the following conditions: <ul style="list-style-type: none"> <li>– Cooling: Indoor temperature of 80 °FDB (26.67 °CDB) / 67 °FWB (19.44 °CWB), and outdoor temperature of 95 °FDB (35 °CDB) / 75 °FWB (23.9 °CWB).</li> <li>– Heating: Indoor temperature of 70 °FDB (21.11 °CDB) / 59 °FWB (15 °CWB), and outdoor temperature of 47 °FDB (8.33 °CDB) / 43 °FWB (6.11 °CWB).</li> <li>– Pipe length: 24 ft 6 in (7.5 m), Height difference: 0 ft (0 m). (Between outdoor unit and indoor unit.)</li> </ul> </li> <li>• Protective function might work when using it outside the operation range.</li> <li>• *1: Maximum operating current is the total current of the indoor unit and the outdoor unit.</li> <li>• *2: Sound pressure level <ul style="list-style-type: none"> <li>– Measured values in manufacturer's anechoic chamber.</li> <li>– Because of the surrounding sound environment, the sound levels measured in actual installation conditions might be higher than the specified values here.</li> </ul> </li> </ul>				

Type				Inverter heat pump				
Model name				AOU18RGLX	AOU24RGLX	AOU30RGLX	AOU36RGLX	
Power supply				208/230 V – 60 Hz				
Power supply intake				Outdoor unit				
Available voltage range				187–253 V				
Starting current				A	6.6	9.6	11.5	16.1
Fan	Airflow rate	Cooling	CFM (m <sup>3</sup> /h)	1,177 (2,000)	2,119 (3,600)	2,119 (3,600)	2,237 (3,800)	
		Heating		1,489 (2,530)	2,119 (3,600)	2,119 (3,600)	2,237 (3,800)	
	Type × Qty	Propeller × 1						
Motor output			W	100				
Sound pressure level *	Cooling		dB (A)	47	53	53	54	
	Heating			50	55	55	56	
Heat exchanger type	Dimensions (H × W × D)		in	31-7/16 × 35-7/16 × 1-7/16				
			mm	798 × 900 × 36.4				
	Fin pitch		FPI	20				
	Rows × Stages			2 × 38				
	Pipe type			Copper				
	Fin		Type (Material)	Aluminum				
		Surface treatment	PC Fin					
Compressor	Type × Qty			Rotary × 1				
	Motor output		W	2,100				
Refrigerant	Type			R410A				
	Charge	lb oz		4 lb 10.1oz				
		g	2,100					
Refrigerant oil	Type			POE (RB68)				
	Amount		in <sup>3</sup> (cm <sup>3</sup> )	48.8 (800)				
Enclosure	Material			Steel				
	Color			Beige Approximate color of Munsell 10YR 7.5/1.0				
Dimensions (H × W × D)	Net		in (mm)	32-11/16 × 35-7/16 × 13 (830 × 900 × 330)				
	Gross		in (mm)	39-3/8 × 41-5/16 × 17-1/2 (1,000 × 1,050 × 445)				
Weight	Net		lb (kg)	134 (61)				
	Gross			152 (69)				
Connection pipe	Size	Liquid	in (mm)	Ø 1/4 (6.35)	Ø 3/8 (9.52)			
		Gas		Ø 1/2 (12.70)	Ø 5/8 (15.88)			
	Method			Flare				
	Pre-charge length		ft (m)	65 (20)				
	Max. length			164 (50)				
	Max. height difference			98 (30)				
Operation range	Cooling		°F (°C)	-5 to 115 (-20 to 46)				
	Heating			-5 to 75 (-20 to 24)				
Drain hose	Material			LDPE				
	Size		in (mm)	Ø1/2 (13.0) [I.D.], Ø5/8 to Ø11/16 (16.0 to 16.7) [O.D.]				
<b>NOTES:</b>								
<ul style="list-style-type: none"> <li>• Specifications are based on the following conditions: <ul style="list-style-type: none"> <li>– Cooling: Indoor temperature of 80 °FDB (26.67 °CDB) / 67 °FWB (19.44 °CWB), and outdoor temperature of 95 °FDB (35 °CDB) / 75 °FWB (23.9 °CWB).</li> <li>– Heating: Indoor temperature of 70 °FDB (21.11 °CDB) / 59 °FWB (15 °CWB), and outdoor temperature of 47 °FDB (8.33 °CDB) / 43 °FWB (6.11 °CWB).</li> <li>– Pipe length: 24 ft 6 in (7.5 m), Height difference: 0 ft (0 m). (Between outdoor unit and indoor unit.)</li> </ul> </li> <li>• Protective function might work when using it outside the operation range.</li> <li>• *: Sound pressure level <ul style="list-style-type: none"> <li>– Measured values in manufacturer's anechoic chamber.</li> <li>– Because of the surrounding sound environment, the sound levels measured in actual installation conditions might be higher than the specified values here.</li> </ul> </li> </ul>								

Type			Inverter heat pump	Inverter heat pump
Model name			AOU42RGLX	AOU48RGLX
Power supply			208/230 V – 60 Hz	
Power supply intake			Outdoor unit	
Available voltage range			187–253 V	
Starting current			A	16.8
Fan	Airflow rate	Cooling	CFM (m <sup>3</sup> /h)	3,973 (6,750)
		Heating		4,061 (6,900)
	Type x Qty	Propeller x 1		
Motor output			W	100
Sound pressure level *		Cooling	dB (A)	55
		Heating		57
Heat exchanger type	Dimensions (H x W x D)		in	49-10/16 x 35-7/16 x 1-7/16
			mm	1,260 x 900 x 36.4
	Fin pitch		FPI	20
	Rows x Stages			2 x 22 2 x 38
	Pipe type			Copper
	Fin		Type (Material) Surface treatment	Aluminum PC Fin
Compressor	Type x Qty		Twin rotary x 1	
	Motor output		W	3,750
Refrigerant	Type		R410A	
	Charge	lb oz		7 lb 10.1oz
		g	3,450	
Refrigerant oil	Type		POE (VG74)	
	Amount	in <sup>3</sup> (cm <sup>3</sup> )	94.6 (1,550)	
Enclosure	Material		Steel	
	Color		Beige Approximate color of MUNSELL 10YR 7.5/1.0	
Dimensions (H x W x D)	Net	in		50-13/16 x 35-7/16 x 13
		mm		1,290 x 900 x 330
	Gross	in		57-1/2 x 41-5/16 x 17-1/2
		mm		1,460 x 1,050 x 445
Weight	Net		209 (95)	
	Gross		231 (105)	
Connection pipe	Size	Liquid	in (mm)	Ø 3/8 (9.52)
		Gas		Ø 5/8 (15.88)
	Method		Flare	
	Pre-charge length		98 (30)	
	Max. length		246 (75)	
	Max. height difference		98 (30)	
Operation range		Cooling	°F (°C)	-5 to 115 (-20 to 46)
		Heating		-5 to 75 (-20 to 24)
Drain hose	Material		LDPE	
	Size		in (mm)	
NOTES: <ul style="list-style-type: none"> <li>Specifications are based on the following conditions:               <ul style="list-style-type: none"> <li>Cooling: Indoor temperature of 80 °FDB (26.67 °CDB) / 67 °FWB (19.44 °CWB), and outdoor temperature of 95 °FDB (35 °CDB) / 75 °FWB (23.9 °CWB).</li> <li>Heating: Indoor temperature of 70 °FDB (21.11 °CDB) / 59 °FWB (15 °CWB), and outdoor temperature of 47 °FDB (8.33 °CDB) / 43 °FWB (6.11 °CWB).</li> <li>Pipe length: 24 ft 6 in (7.5 m), Height difference: 0 ft (0 m). (Between outdoor unit and indoor unit.)</li> </ul> </li> <li>Protective function might work when using it outside the operation range.</li> <li>*1: Sound pressure level               <ul style="list-style-type: none"> <li>Measured values in manufacturer's anechoic chamber.</li> <li>Because of the surrounding sound environment, the sound levels measured in actual installation conditions might be higher than the specified values here.</li> </ul> </li> </ul>				

# Dimensions

## Models: AUU18RGLX and AUU24RGLX

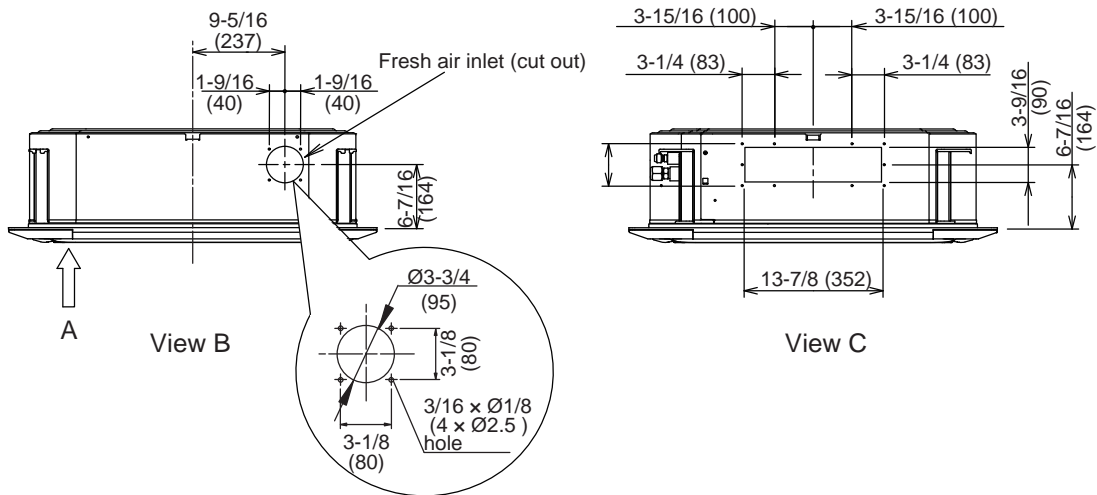
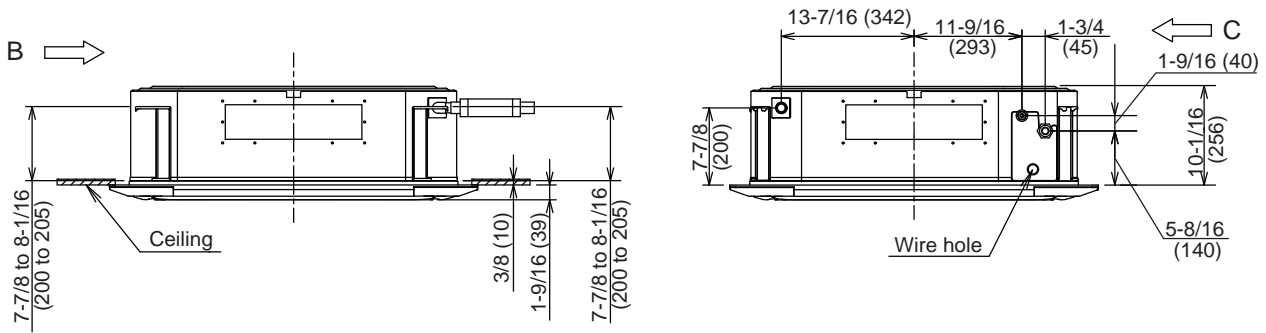
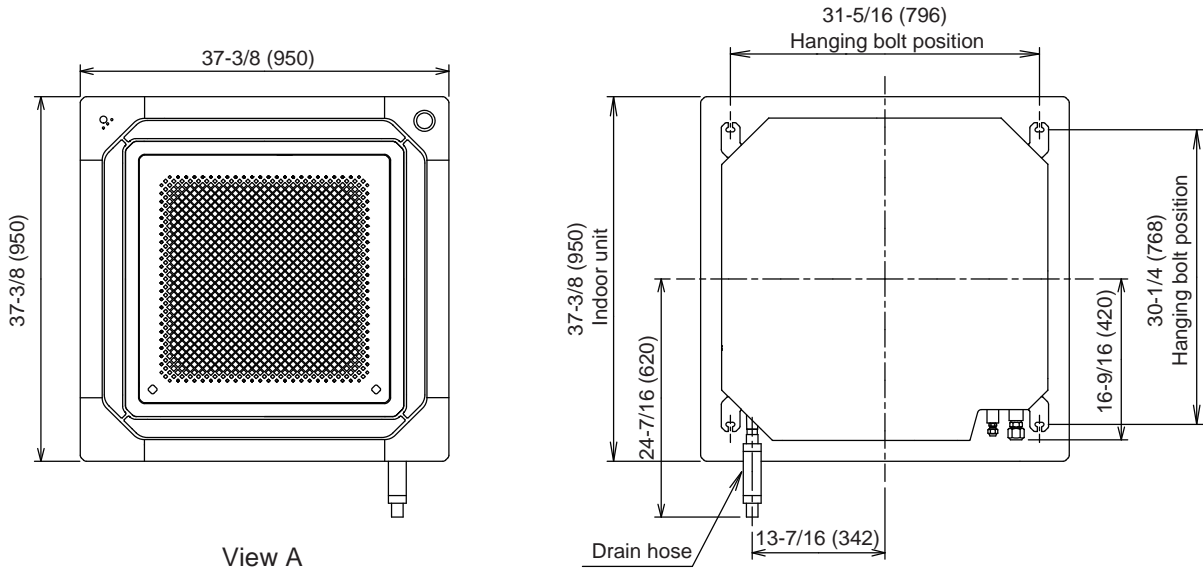



# Models: AUU30RGLX, AUU36RGLX, AUU42RGLX, and AUU48RGLX

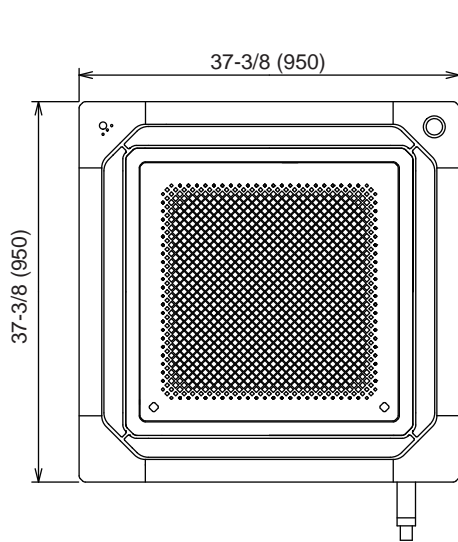

View A

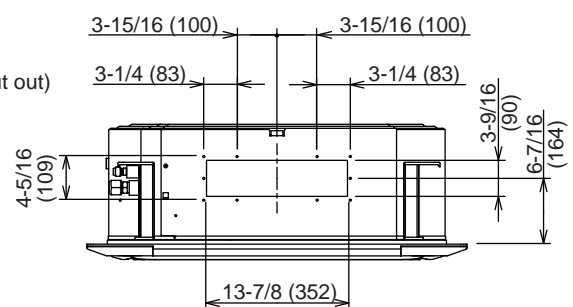
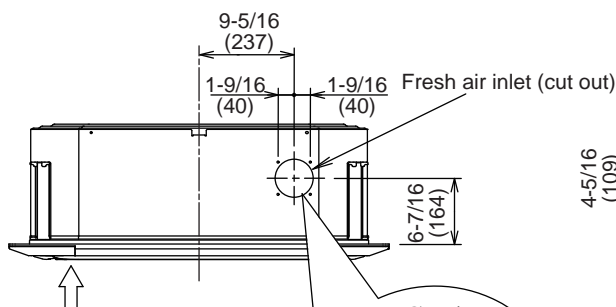
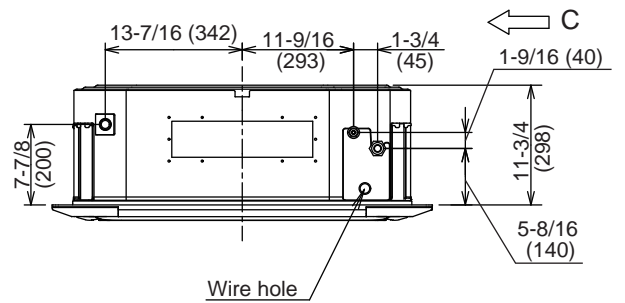
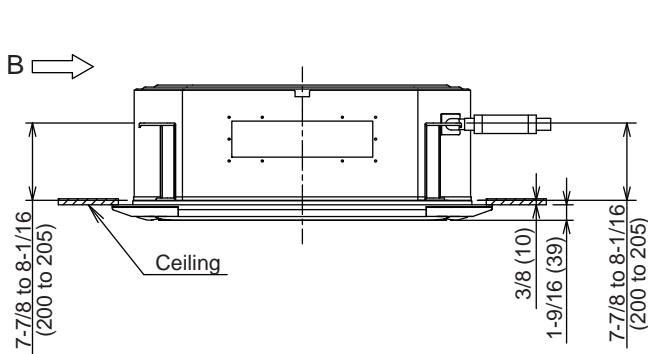
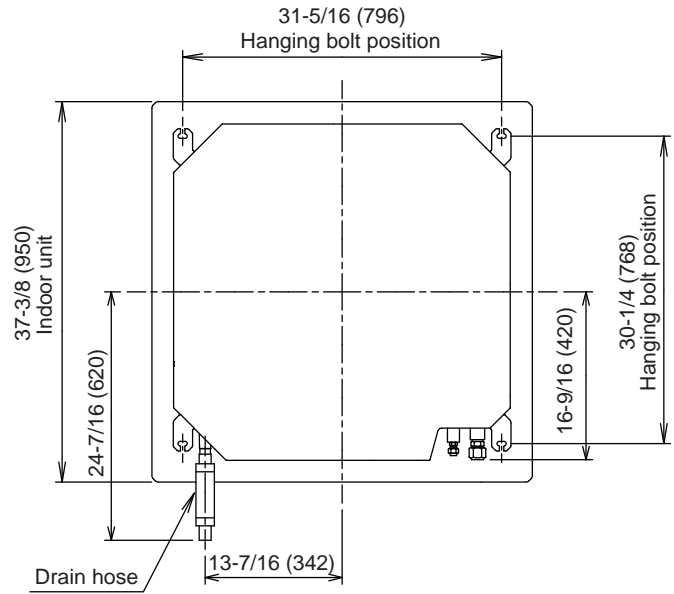

View B

View C

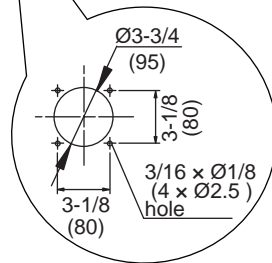

# Models: AOU18RGLX, AOU24RGLX, AOU30RGLX, and AOU36RGLX

Unit: in (mm)

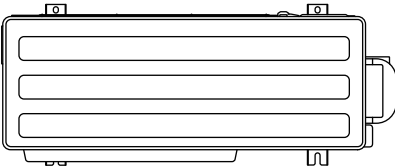

Top view

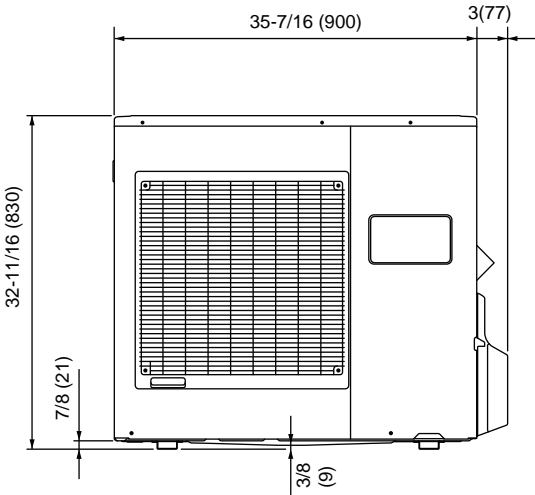

Front view

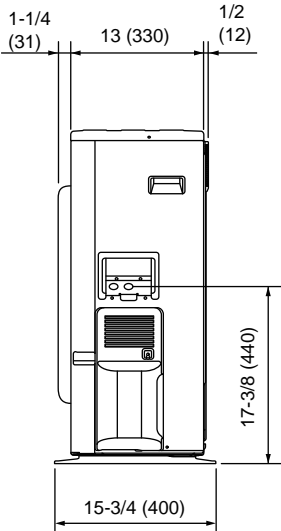

Side view

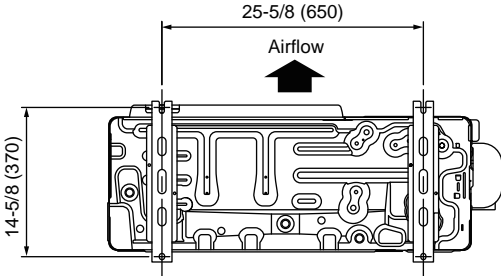

Bottom view

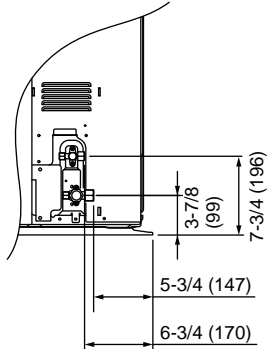

# Models: AOU42RGLX and AOU48RGLX

Unit: in (mm)

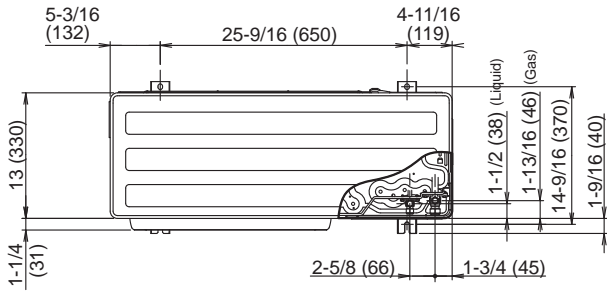

Top view

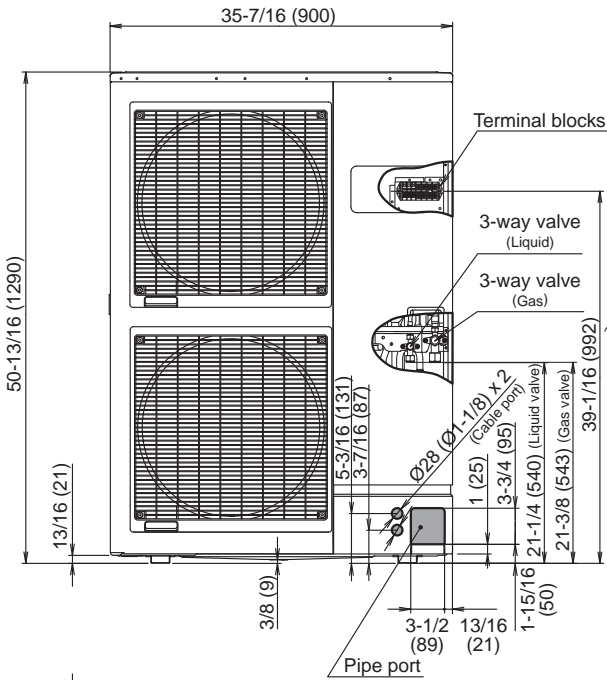

Front view

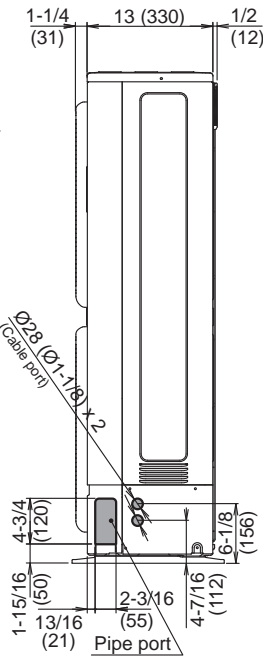

Side view

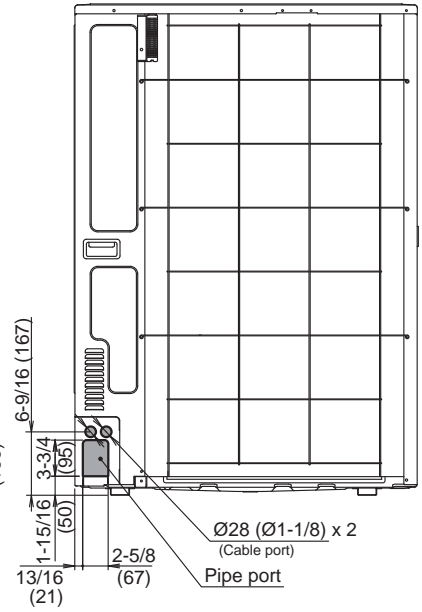

Rear view

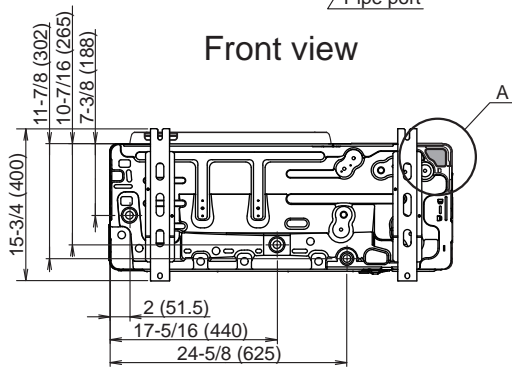

Bottom view

## Detail A

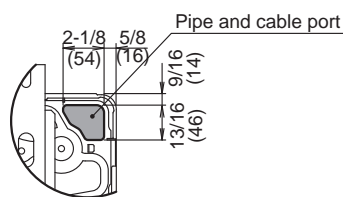

# Refrigerant circuit

**Models: AOU18RGLX, AOU24RGLX, AOU30RGLX, and AOU36RGLX**

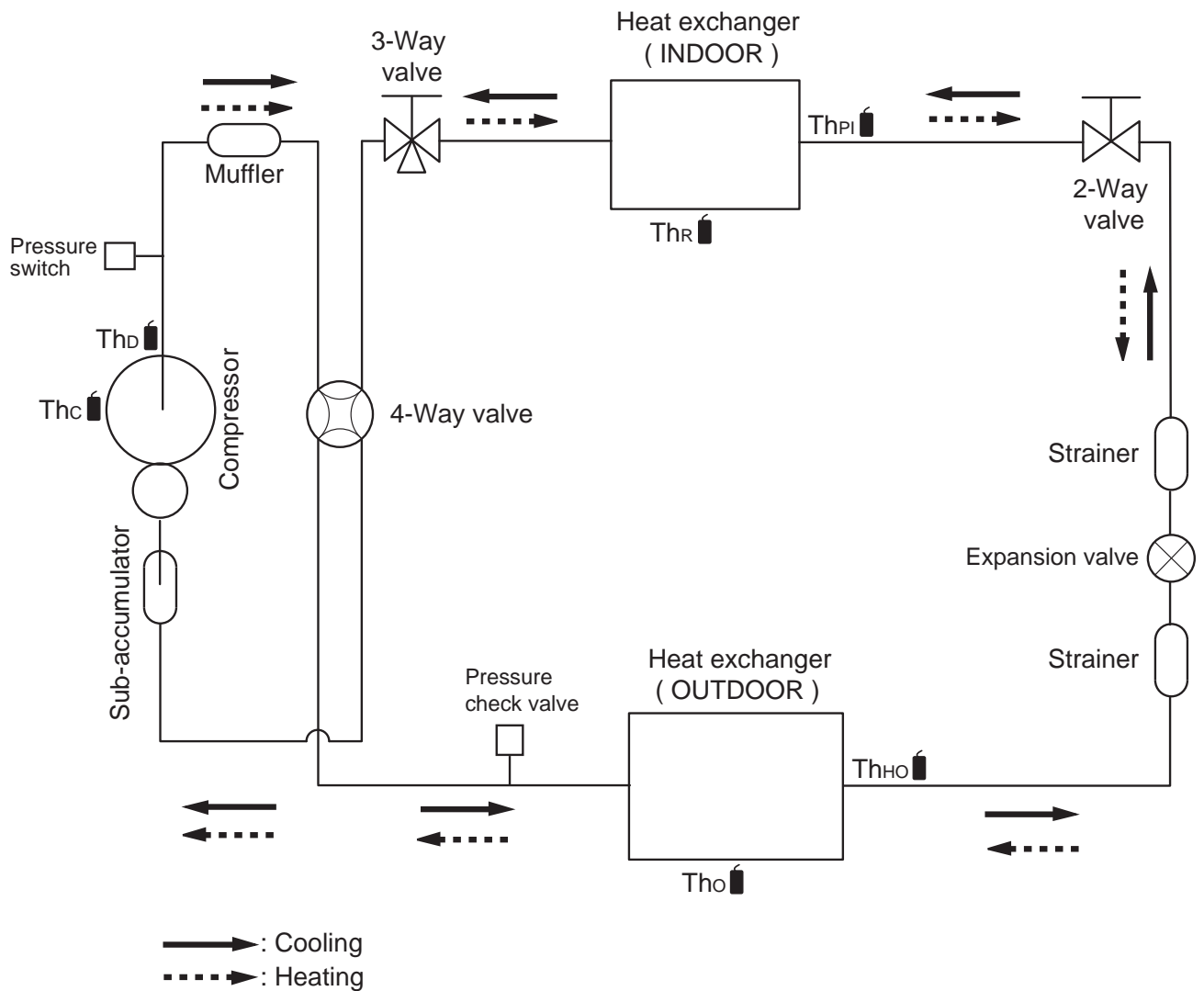

- Th<sub>c</sub> : Thermistor (Compressor temperature)
- Th<sub>d</sub> : Thermistor (Discharge temperature)
- Th<sub>o</sub> : Thermistor (Outdoor temperature)
- Th<sub>Ho</sub> : Thermistor (Heat Exchanger Out temperature)
- Th<sub>R</sub> : Thermistor (Room temperature)
- Th<sub>PI</sub> : Thermistor (Pipe temperature)

# Models: AOU42RGLX and AOU48RGLX

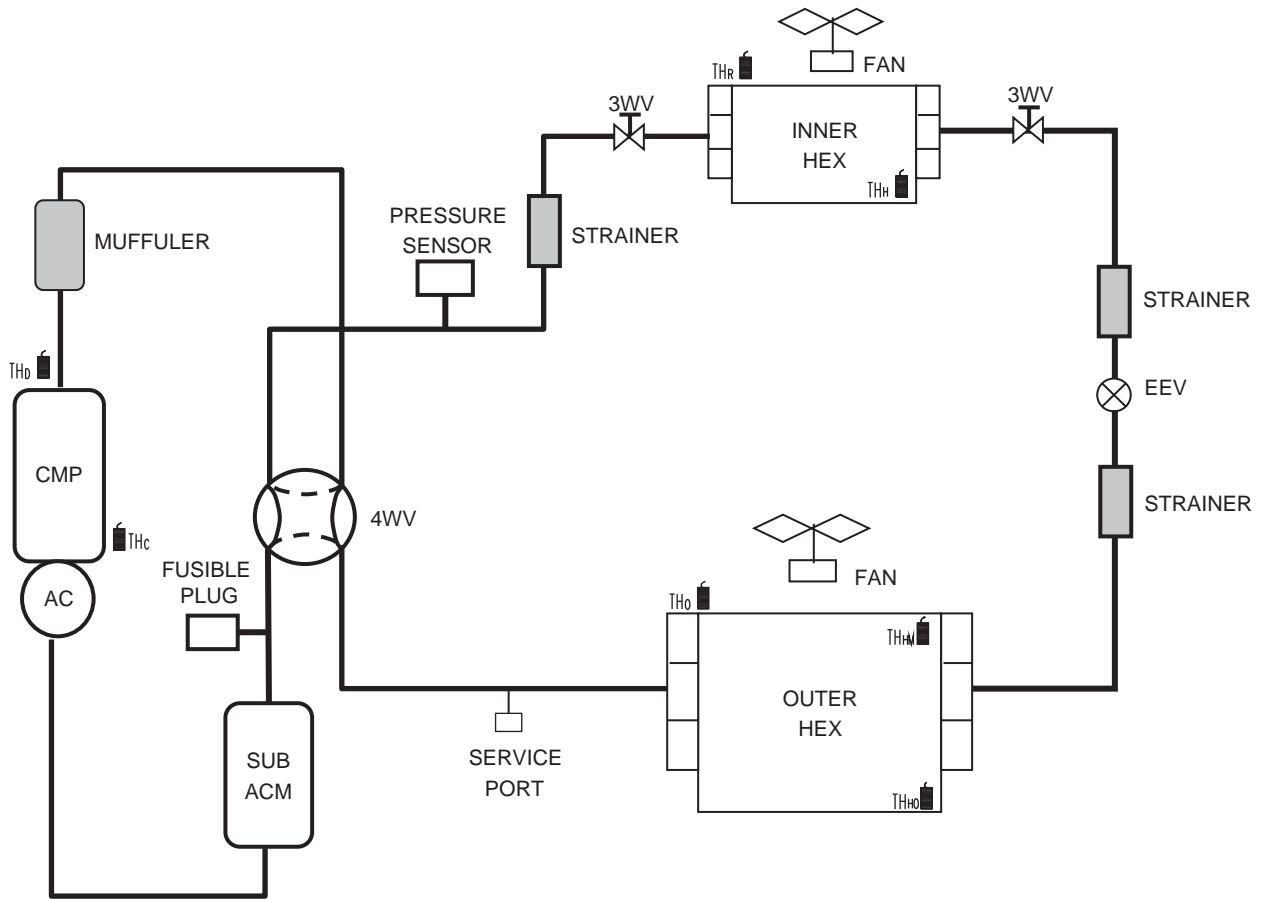

THc : Thermistor (Compressor temperature)

THo : Thermistor (Discharge temperature)

THw : Thermistor (Heat Exchanger Med temperature)

THHo : Thermistor (Heat Exchanger Out temperature)

THo : Thermistor (Outdoor temperature)

THr : Thermistor (Room temperature)

THH : Thermistor (Heat exchanger temperature)

# PCB CIRCUIT DIAGRAM

**CONTROL UNIT**  
 AUU18RGLX : EZ-0183HSE  
 AUU24RGLX : EZ-0184HSE  
 AUU30RGLX : EZ-0185HSE  
 AUU36RGLX : EZ-0186HSE  
 AUU42RGLX : EZ-018RHSE  
 AUU48RGLX : EZ-0187HSE

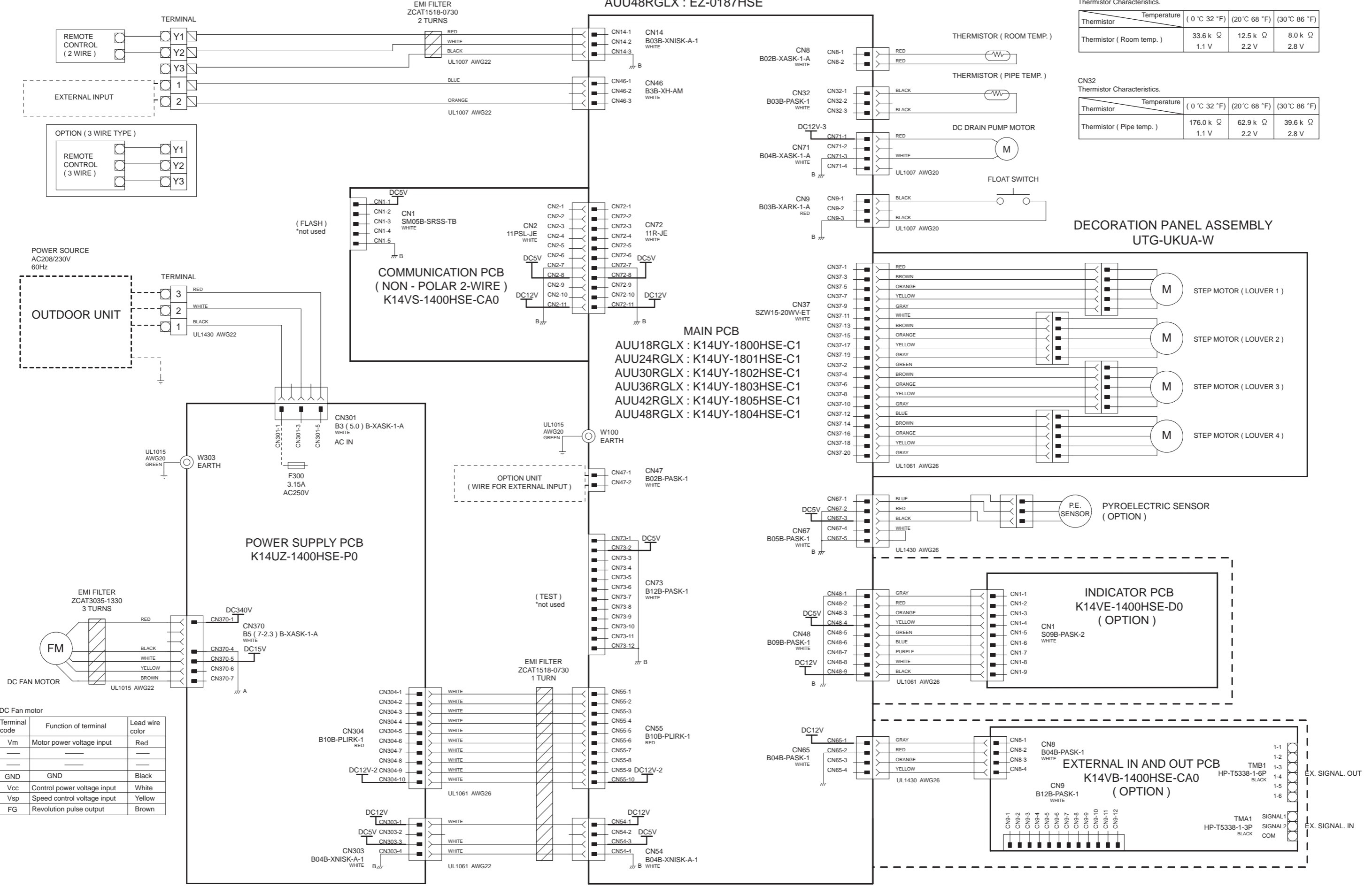

CN8 Thermistor Characteristics.

Thermistor	Temperature	(0 °C 32 °F)	(20 °C 68 °F)	(30 °C 86 °F)
Thermistor ( Room temp. )		33.6 k Ω	12.5 k Ω	8.0 k Ω
		1.1 V	2.2 V	2.8 V

CN32 Thermistor Characteristics.

Thermistor	Temperature	(0 °C 32 °F)	(20 °C 68 °F)	(30 °C 86 °F)
Thermistor ( Pipe temp. )		176.0 k Ω	62.9 k Ω	39.6 k Ω
		1.1 V	2.2 V	2.8 V

CN370 DC Fan motor

Pin No.	Terminal code	Function of terminal	Lead wire color
1	Vm	Motor power voltage input	Red
2			
3			
4	GND	GND	Black
5	Vcc	Control power voltage input	White
6	Vsp	Speed control voltage input	Yellow
7	FG	Revolution pulse output	Brown

INVERTER ASSEMBLY  
EZ-0182HUE

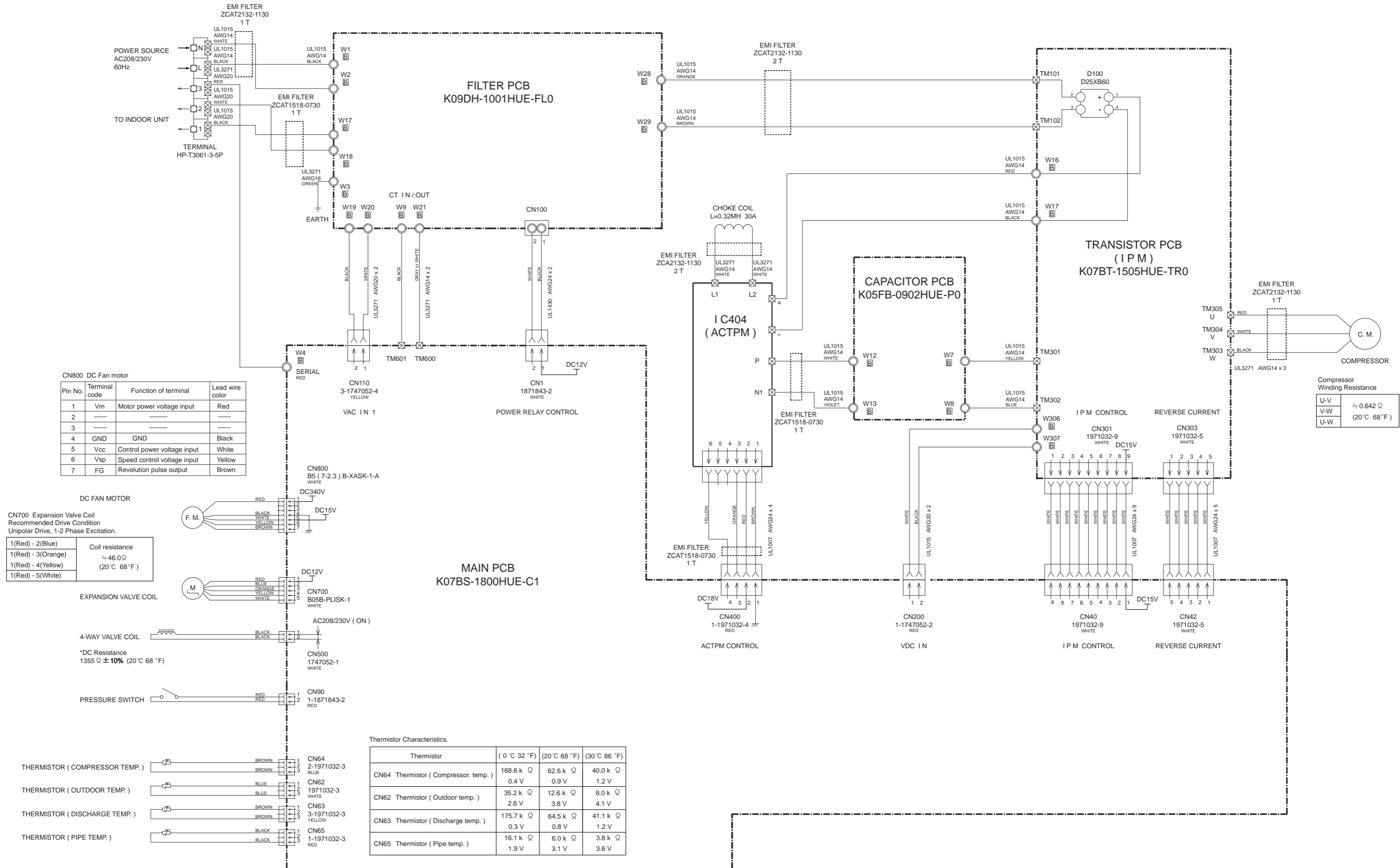

CN800 DC Fan motor

Pin No.	Terminal code	Function of terminal	Lead wire color
1	Vm	Motor power voltage input	Red
2	---	---	---
3	---	---	---
4	GND	GND	Black
5	Vcc	Control power voltage input	White
6	Vsp	Speed control voltage input	Yellow
7	FG	Revolution pulse output	Brown

DC FAN MOTOR

CN700 Expansion Valve Coil  
Recommended Drive Condition  
Unipolar Drive, 1-2 Phase Excitation.

Terminal	Coil resistance
1(Red) - 2(Blue)	≈ 46.0 Ω (20°C 68°F)
1(Red) - 3(Orange)	
1(Red) - 4(Yellow)	
1(Red) - 5(White)	

Compressor Winding Resistance

U-V	≈ 0.642 Ω
V-W	
U-W	(20°C 68°F)

Thermistor Characteristics.

Thermistor	(0°C 32°F)	(20°C 68°F)	(30°C 86°F)
CN64 Thermistor ( Compressor. temp. )	168.6 k Ω 0.4 V	62.6 k Ω 0.9 V	40.0 k Ω 1.2 V
CN62 Thermistor ( Outdoor temp. )	35.2 k Ω 2.6 V	12.6 k Ω 3.8 V	8.0 k Ω 4.1 V
CN63 Thermistor ( Discharge temp. )	175.7 k Ω 0.3 V	64.5 k Ω 0.8 V	41.1 k Ω 1.2 V
CN65 Thermistor ( Pipe temp. )	16.1 k Ω 1.9 V	6.0 k Ω 3.1 V	3.8 k Ω 3.6 V

Models : AOU24RGLX  
 AOU30RGLX  
 AOU36RGLX

INVERTER ASSEMBLY  
 AOU24RGLX : EZ-0183HUE  
 AOU30RGLX : EZ-0184HUE  
 AOU36RGLX : EZ-0185HUE

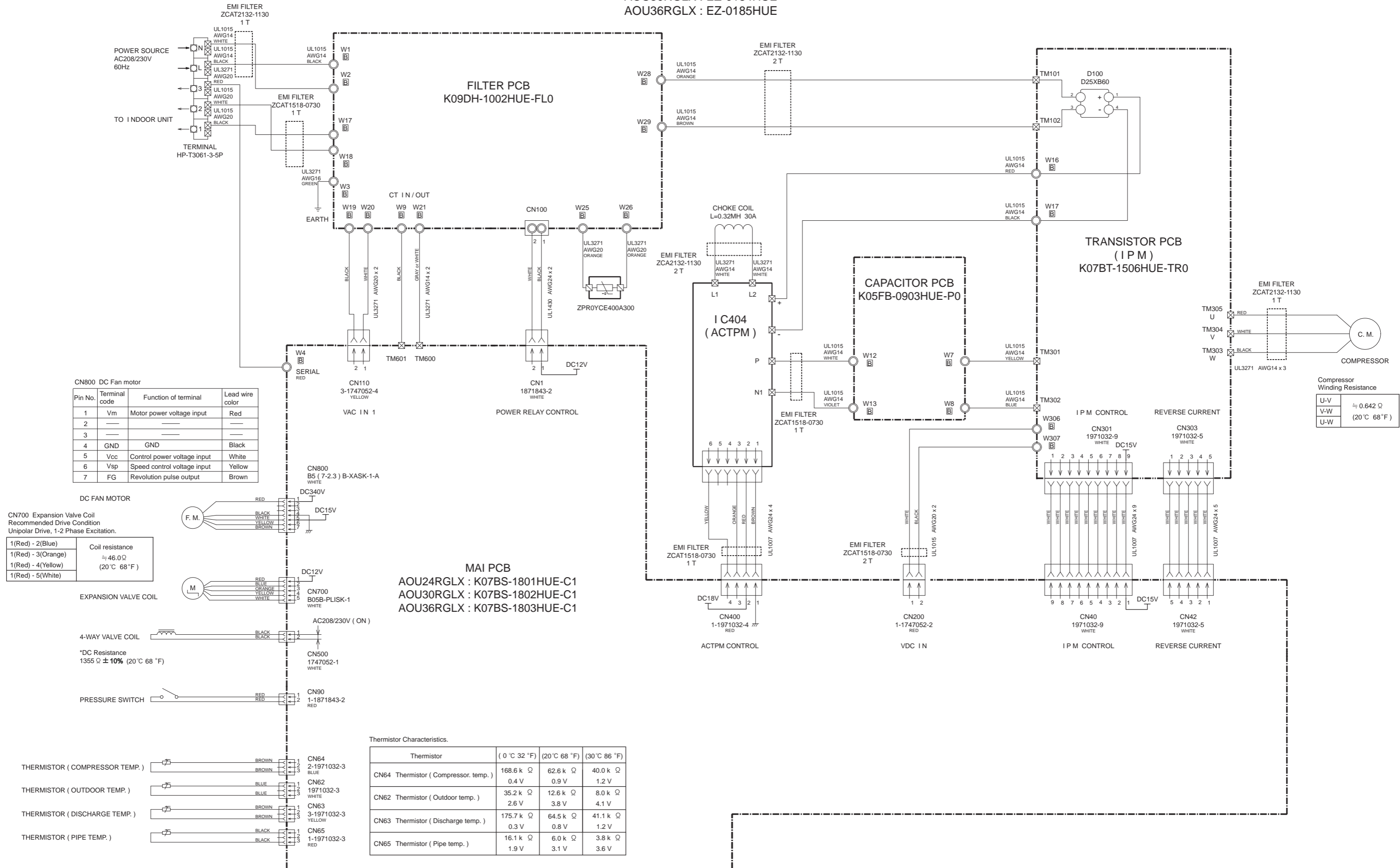

CN800 DC Fan motor

Pin No.	Terminal code	Function of terminal	Lead wire color
1	Vm	Motor power voltage input	Red
2			
3			
4	GND	GND	Black
5	Vcc	Control power voltage input	White
6	Vsp	Speed control voltage input	Yellow
7	FG	Revolution pulse output	Brown

DC FAN MOTOR

CN700 Expansion Valve Coil  
 Recommended Drive Condition  
 Unipolar Drive, 1-2 Phase Excitation.

Lead	Coil resistance
1(Red) - 2(Blue)	≈ 46.0 Ω (20°C 68°F)
1(Red) - 3(Orange)	
1(Red) - 4(Yellow)	
1(Red) - 5(White)	

Compressor Winding Resistance

U-V	≈ 0.642 Ω
V-W	
U-W	(20°C 68°F)

Thermistor Characteristics.

Thermistor	(0 °C 32 °F)	(20°C 68 °F)	(30°C 86 °F)
CN64 Thermistor ( Compressor. temp. )	168.6 k Ω 0.4 V	62.6 k Ω 0.9 V	40.0 k Ω 1.2 V
CN62 Thermistor ( Outdoor temp. )	35.2 k Ω 2.6 V	12.6 k Ω 3.8 V	8.0 k Ω 4.1 V
CN63 Thermistor ( Discharge temp. )	175.7 k Ω 0.3 V	64.5 k Ω 0.8 V	41.1 k Ω 1.2 V
CN65 Thermistor ( Pipe temp. )	16.1 k Ω 1.9 V	6.0 k Ω 3.1 V	3.8 k Ω 3.6 V



INVERTER ASSEMBLY  
AOU42RGLX : EZ-0181RHUE  
AOU48RGLX : EZ-0181PHUE

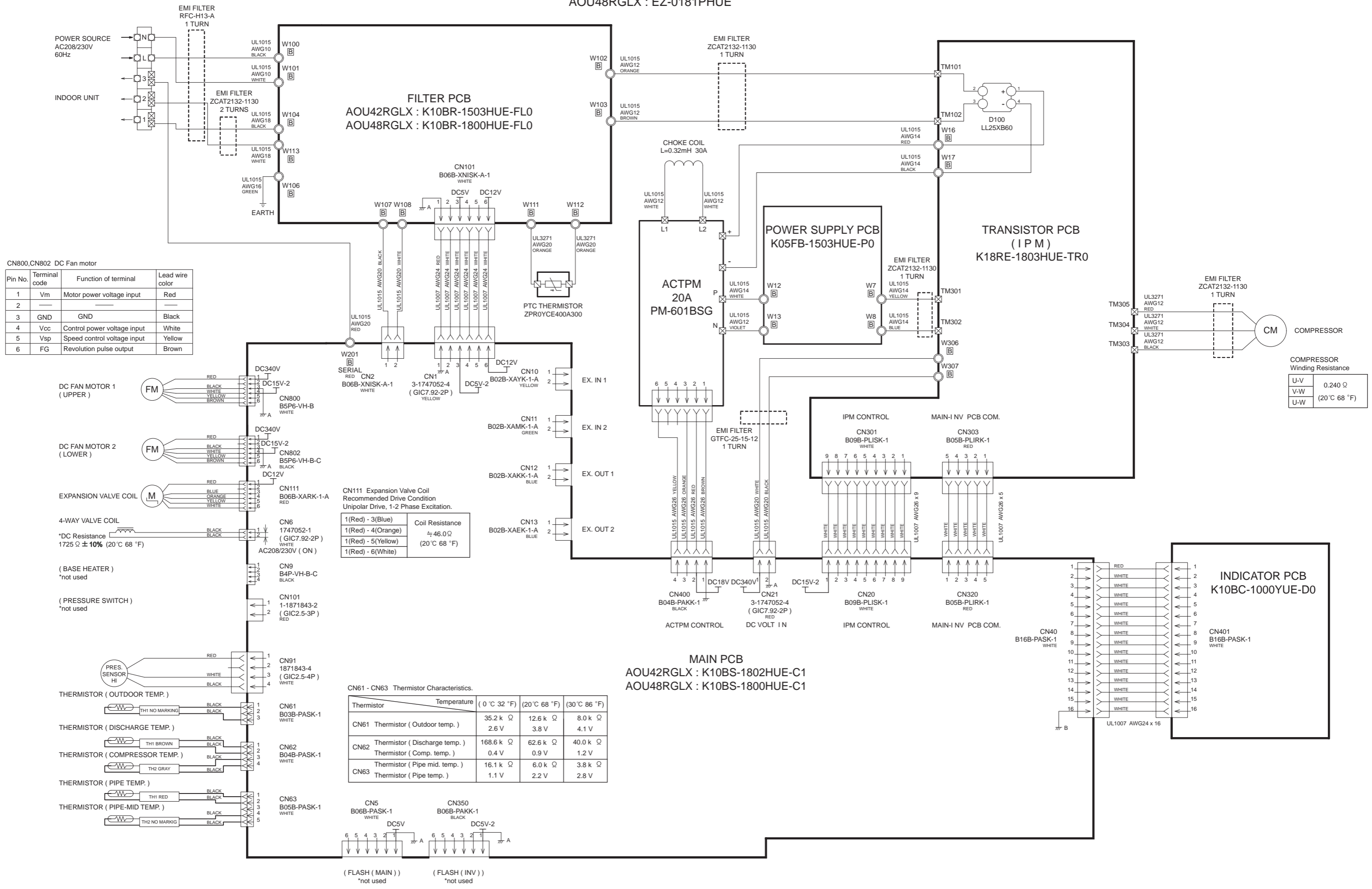

# ERROR CODE

If you use a wired type remote controller, error codes will appear on the remote controller display. For more information, refer to the installation manual of the remote controller. If you use a wireless remote controller, the lamps on the IR receiver unit will output error codes by way of blinking patterns. Refer to the lamp blinking patterns and error codes in the table below. An error display is displayed only during operation.

## [Error code display on the indoor unit (option)]

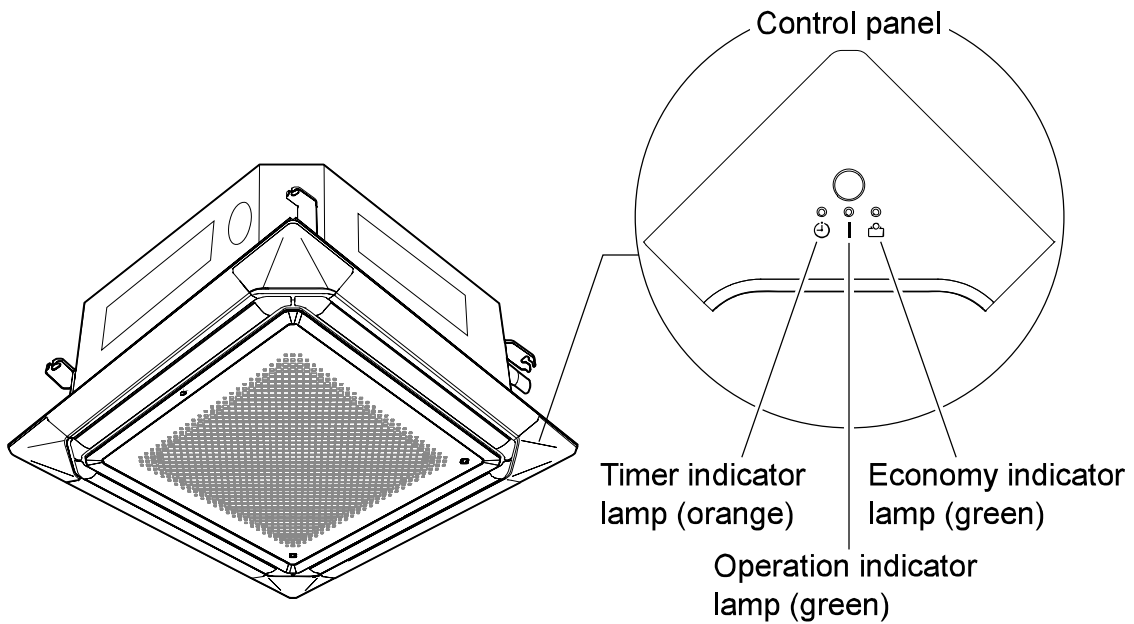

## [Error code display on the wired remote controller (option)]

### Check the error

1. If an error occurs, an error icon appears on the “Monitor mode screen”. Touch the [Status] on the “Monitor mode screen”. The “Status” screen is displayed.
2. Touch the [Error Information] on the “Status” screen. The “Error Information” screen is displayed. (If there are no errors, the [Error Information] will not be displayed.)
3. 2-digit numbers correspond to the error code in the table below. Touch the [Next page] (or [Previous page]) to switch to other connected indoor units.

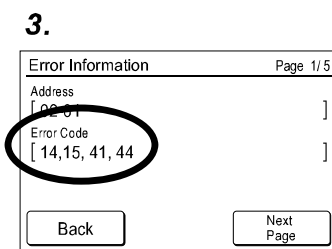
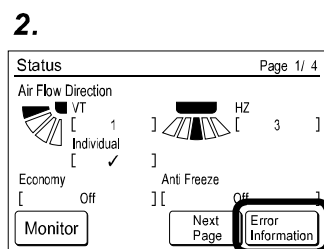
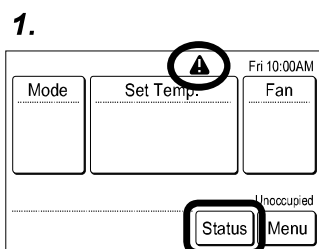

Error display			Wired remote controller Error code	Description
Operation indicator lamp (green)	Timer indicator lamp (orange)	Economy indicator lamp (green)		
●(1)	●(1)	◇	11	Serial communication error
●(1)	●(2)	◇	12	Wired remote controller communication error
●(1)	●(5)	◇	15	Check run unfinished
●(1)	●(6)	◇	16	Peripheral unit transmission PCB connection error
●(1)	●(8)	◇	18	External communication error
●(2)	●(1)	◇	21	Unit number or Refrigerant circuit address setting error [Simultaneous Multi]
●(2)	●(2)	◇	22	Indoor unit capacity error
●(2)	●(3)	◇	23	Combination error
●(2)	●(4)	◇	24	• Connection unit number error (indoor secondary unit) [Simultaneous Multi] • Connection unit number error (indoor unit or branch unit) [Flexible Multi]
●(2)	●(6)	◇	26	Indoor unit address setting error
●(2)	●(7)	◇	27	Primary unit, secondary unit setup error [Simultaneous Multi]
●(2)	●(9)	◇	29	Connection unit number error in wired remote controller system
●(3)	●(1)	◇	31	Power supply interruption error
●(3)	●(2)	◇	32	Indoor unit PCB model information error
●(3)	●(3)	◇	33	Indoor unit motor electricity consumption detection error
●(3)	●(5)	◇	35	Manual auto switch error
●(3)	●(9)	◇	39	Indoor unit power supply error for fan motor
●(3)	●(10)	◇	3A	Indoor unit communication circuit (wired remote controller) error
●(4)	●(1)	◇	41	Room temp. sensor error
●(4)	●(2)	◇	42	Indoor unit Heat Ex. Middle temp. sensor error
●(4)	●(4)	◇	44	Human sensor error
●(5)	●(1)	◇	51	Indoor unit fan motor error
●(5)	●(3)	◇	53	Drain pump error
●(5)	●(4)	◇	54	Electric air cleaner reverse VDD error
●(5)	●(5)	◇	55	Filter set error
●(5)	●(7)	◇	57	Damper error
●(5)	●(8)	◇	58	Intake grille error
●(5)	●(9)	◇	59	Indoor unit fan motor 2 error (Left side fan)
●(5)	●(10)	◇	5A	Indoor unit fan motor 3 error (Right side fan)

Error display			Wired remote controller Error code	Description
Operation indicator lamp (green)	Timer indicator lamp (orange)	Economy indicator lamp (green)		
●(5)	●(15)	◇	5U	Indoor unit error
●(6)	●(1)	◇	61	Outdoor unit reverse/missing phase and wiring error
●(6)	●(2)	◇	62	Outdoor unit main PCB model information error or communication error
●(6)	●(3)	◇	63	Inverter error
●(6)	●(4)	◇	64	Active filter error, PFC circuit error
●(6)	●(5)	◇	65	Trip terminal L error
●(6)	●(8)	◇	68	Outdoor unit rush current limiting resistor temp. rise error
●(6)	●(10)	◇	6A	Display PCB microcomputers communication error
●(7)	●(1)	◇	71	Discharge temp. sensor error
●(7)	●(2)	◇	72	Compressor temp. sensor error
●(7)	●(3)	◇	73	Outdoor unit Heat Ex. liquid temp. sensor error
●(7)	●(4)	◇	74	Outdoor temp. sensor error
●(7)	●(5)	◇	75	Suction Gas temp. sensor error
●(7)	●(6)	◇	76	• 2-way valve temp. sensor error • 3-way valve temp. sensor error
●(7)	●(7)	◇	77	Heat sink temp. sensor error
●(8)	●(2)	◇	82	• Sub-cool Heat Ex. gas inlet temp. sensor error • Sub-cool Heat Ex. gas outlet temp. sensor error
●(8)	●(3)	◇	83	Liquid pipe temp. sensor error
●(8)	●(4)	◇	84	Current sensor error
●(8)	●(6)	◇	86	• Discharge pressure sensor error • Suction pressure sensor error • High pressure switch error
●(9)	●(4)	◇	94	Trip detection
●(9)	●(5)	◇	95	Compressor rotor position detection error (permanent stop)
●(9)	●(7)	◇	97	Outdoor unit fan motor 1 error
●(9)	●(8)	◇	98	Outdoor unit fan motor 2 error
●(9)	●(9)	◇	99	4-way valve error
●(9)	●(10)	◇	9A	Coil (expansion valve) error
●(10)	●(1)	◇	A1	Discharge temp. error
●(10)	●(3)	◇	A3	Compressor temp. error
●(10)	●(4)	◇	A4	High pressure error
●(10)	●(5)	◇	A5	Low pressure error
●(13)	●(2)	◇	J2	Branch boxes error [Flexible Multi]

Display mode ● : 0.5s ON / 0.5s OFF  
◇ : 0.1s ON / 0.1s OFF  
( ) : Number of flashing

# PARTS

## DECORATION PANEL UTG-GCGF

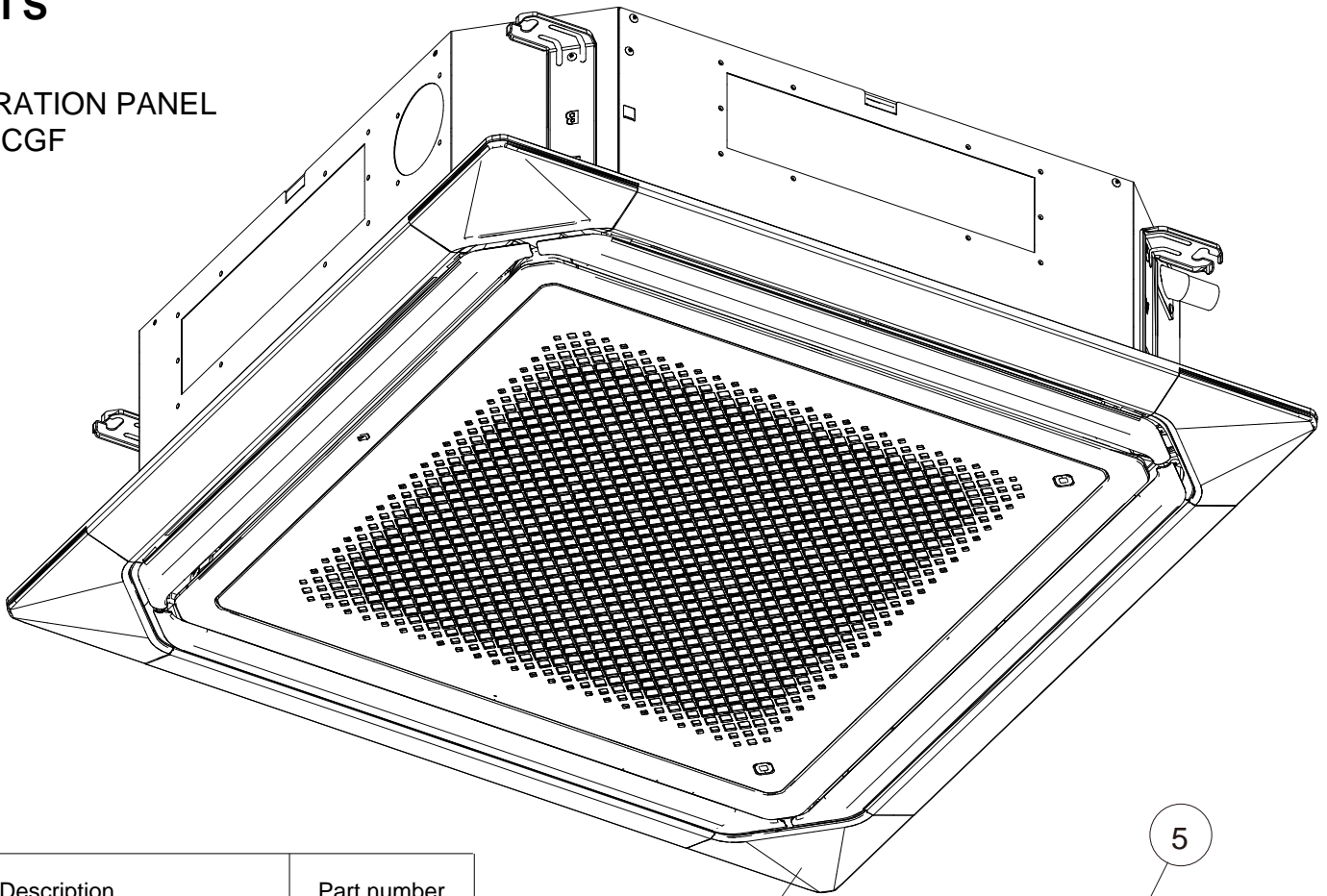

Ref.	Description	Part number
1	Corner panel assy	9381711000
2	Intake grille assy printed	9381690091
3	Longlife Filter	9378252028
4	Filter Guide	9378253018
5	Switch Holder	9381362004
6	Switch Spring	9381688005
7	Switch	9381363001

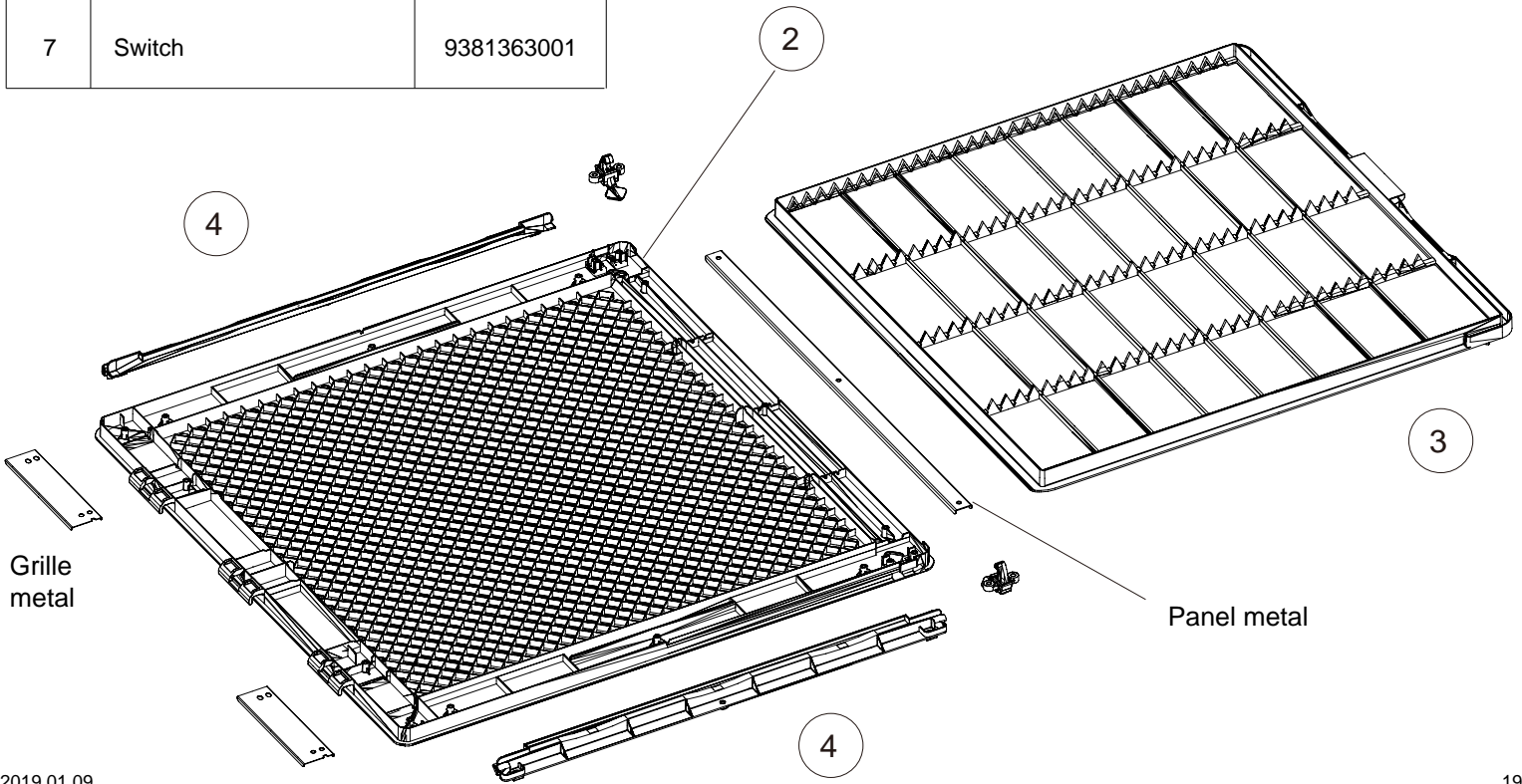
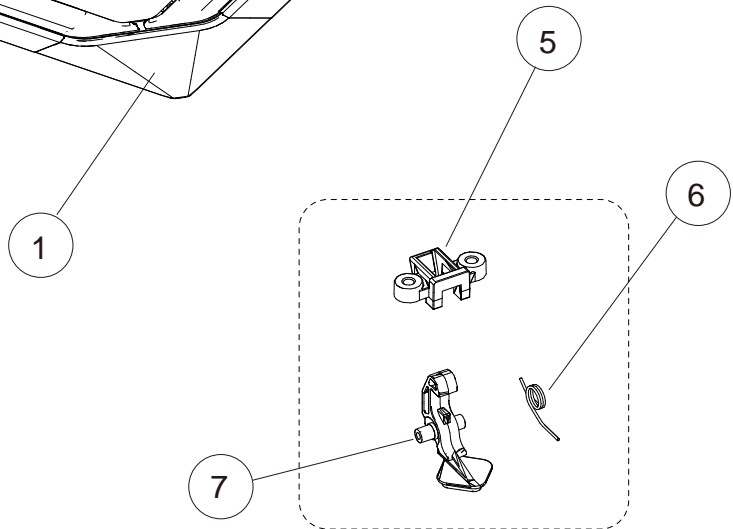

Grille metal

Panel metal

DECORATION PANEL  
UTG-GCGF

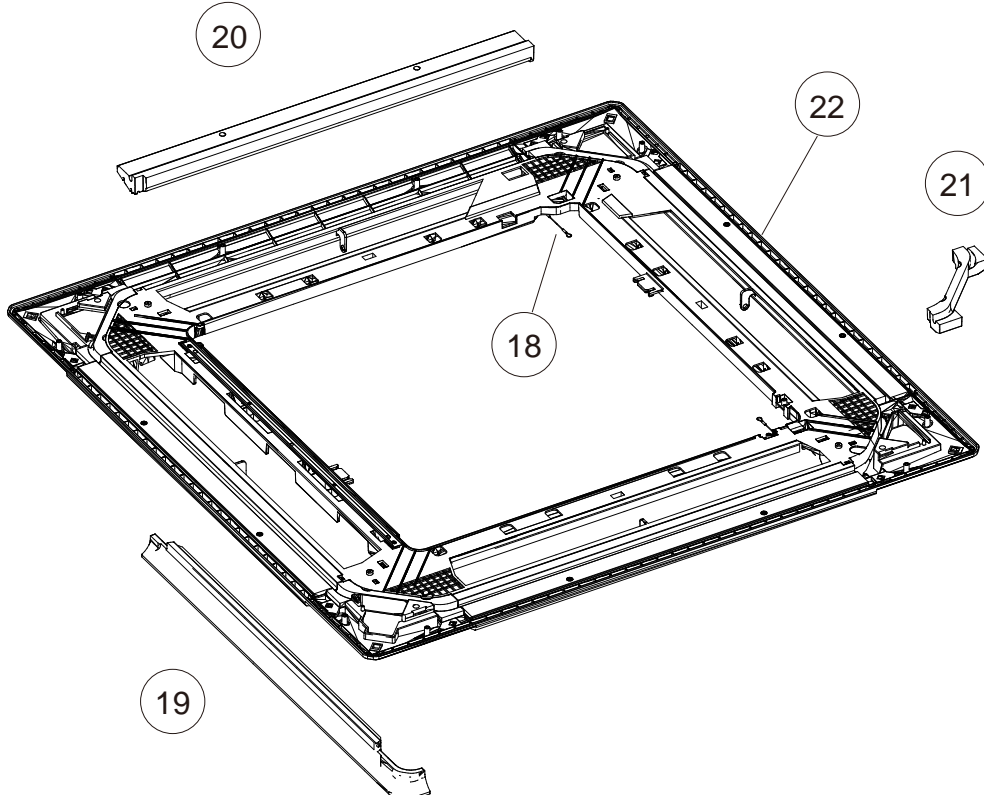
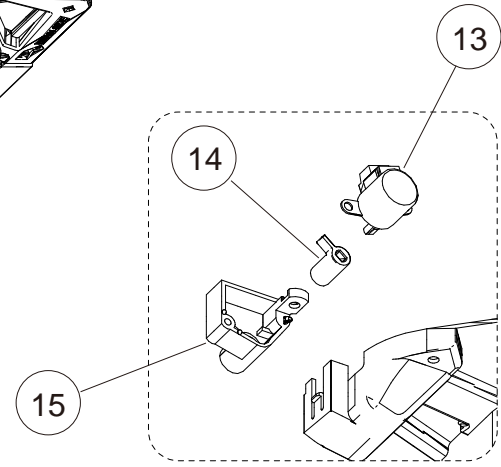
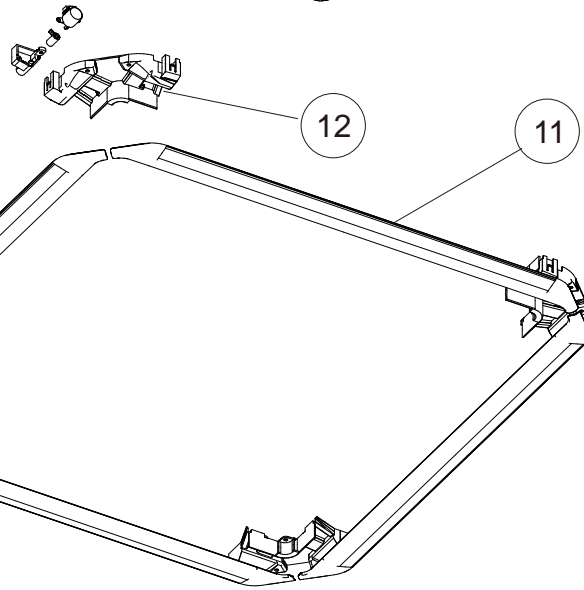
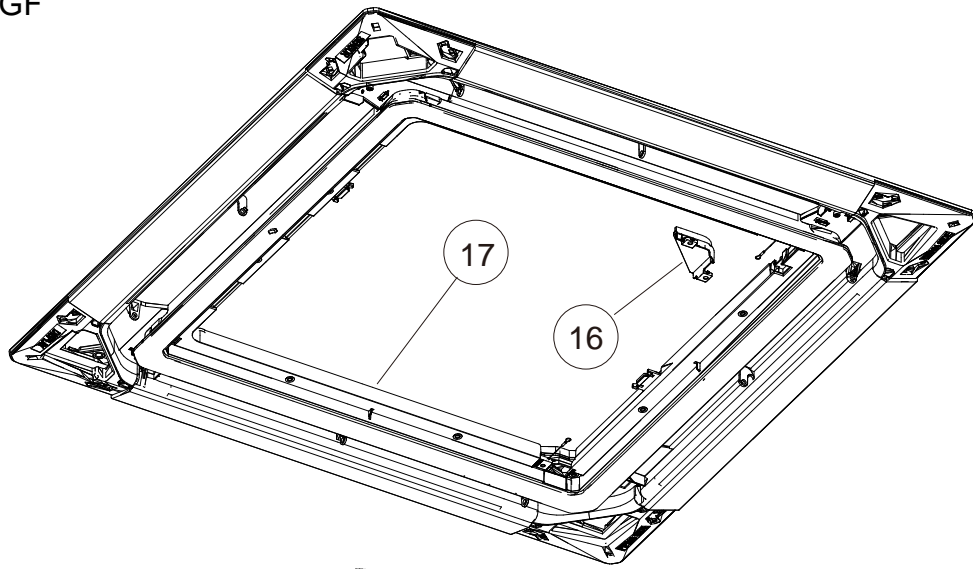

Ref.	Description	Part number
11	Louver assy	9381693009
12	Motor cover	9381354009
13	Step motor	9900885007
14	Shaft cover	9381357000
15	Motor case	9381356003
16	Drain cover assy	9381713004
17	Bezel	9381353002
18	Hook wire	9378597020
19	Panel insulation A	9381359004
20	Panel insulation B	9381360000
21	Panel insulation C	9381355006
22	Decoration panel	9381352005

# PARTS

INDOOR UNIT  
AUU18RGLX  
AUU24RGLX

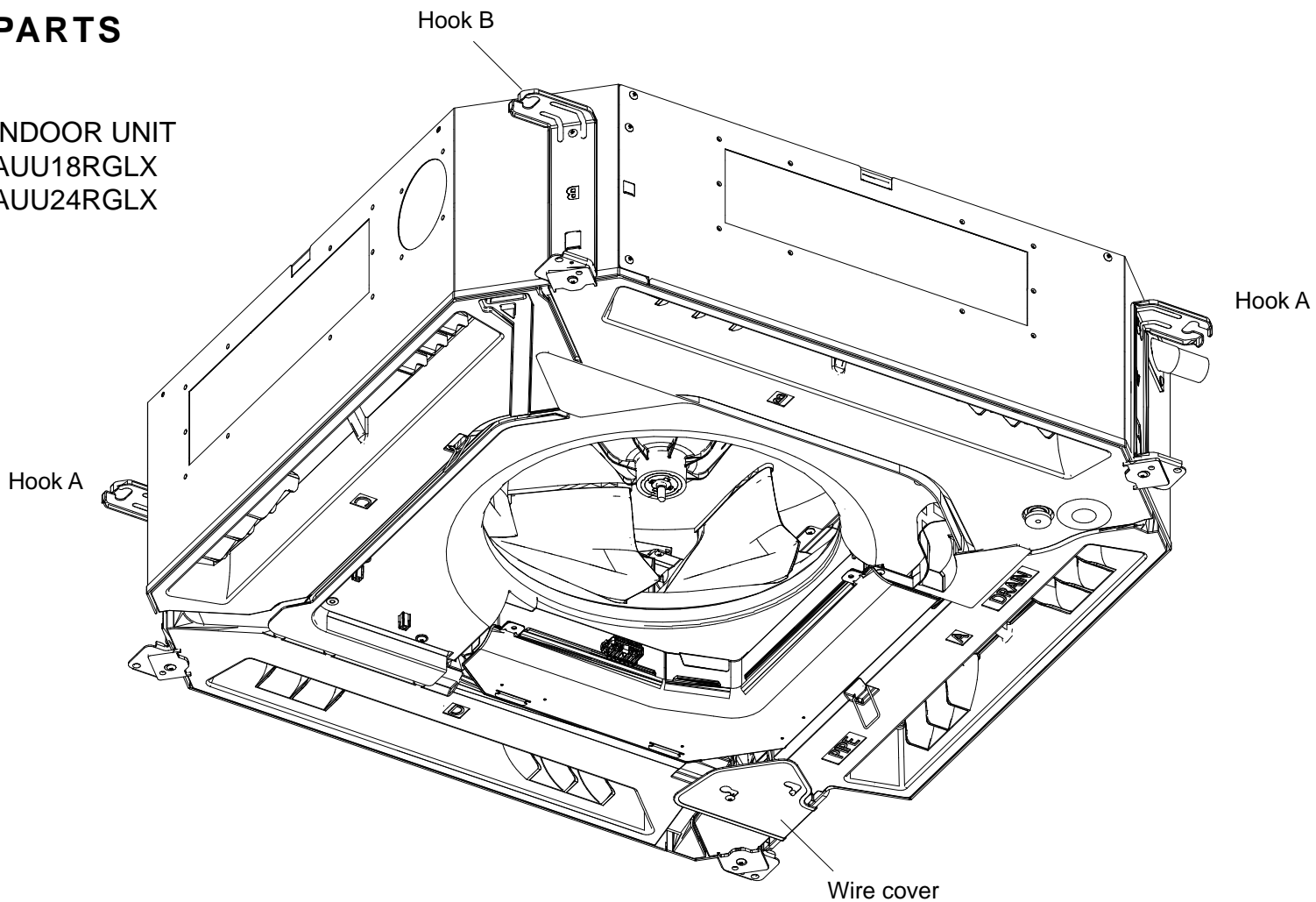

INDOOR UNIT  
AUU30RGLX  
AUU36RGLX  
AUU42RGLX  
AUU48RGLX

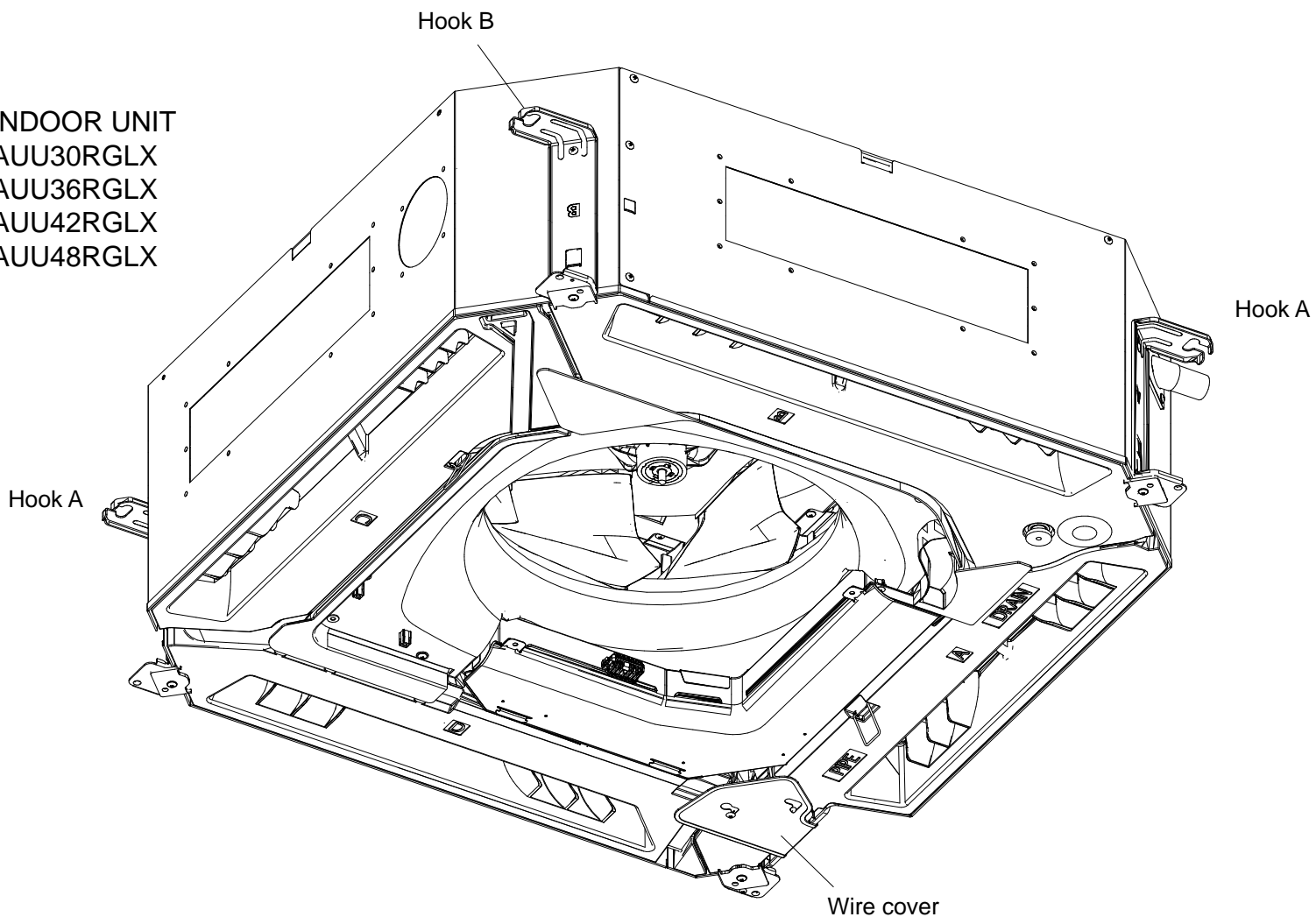

INDOOR UNIT  
 AUU18RGLX  
 AUU24RGLX  
 AUU30RGLX  
 AUU36RGLX  
 AUU42RGLX  
 AUU48RGLX

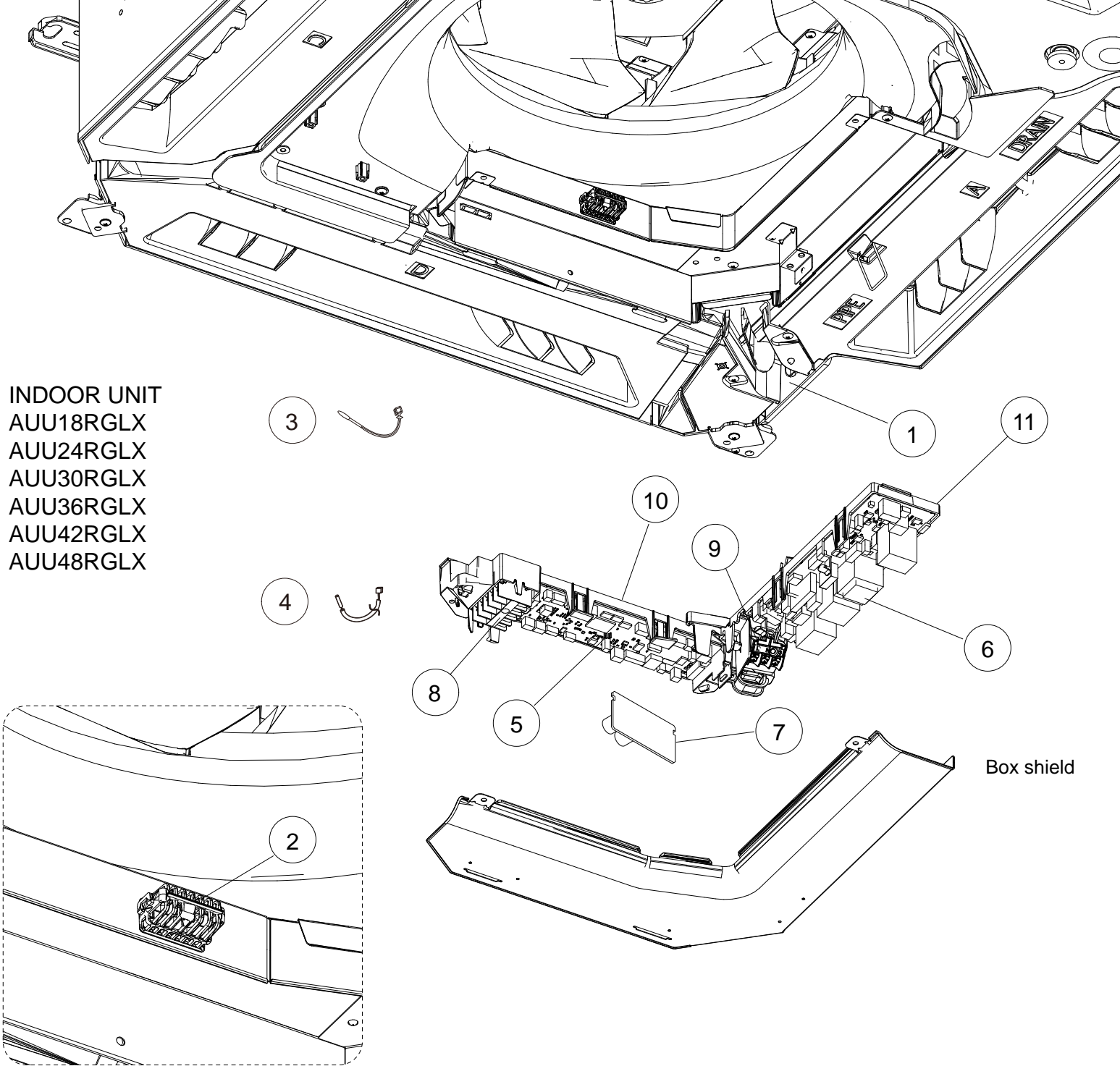

Ref.	Description	Part number
1	Cable guide	9381376018
2	Room thermistor holder	9381348008
3	Room thermistor	9900822002
4	Pipe thermistor	9900942014
5	Main PCB (AUU18RGLX)	9710995538
5	Main PCB (AUU24RGLX)	9710995545
5	Main PCB (AUU30RGLX)	9710995552
5	Main PCB (AUU36RGLX)	9710995569
5	Main PCB (AUU42RGLX)	9710995583

Ref.	Description	Part number
5	Main PCB (AUU48RGLX)	9710995576
6	Power PCB	9710022005
7	PCB (Non-polar 2-wire)	9710019005
8	Remote terminal 5P	9900896003
9	Power terminal 3P	9900720032
10	Main PCB holder	9381350001
11	Power PCB holder	9381349005

INDOOR UNIT  
 AUU18RGLX  
 AUU24RGLX  
 AUU30RGLX  
 AUU36RGLX  
 AUU42RGLX  
 AUU48RGLX

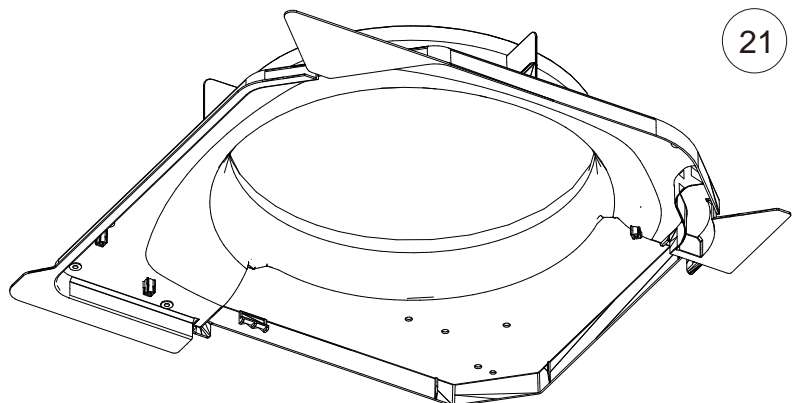
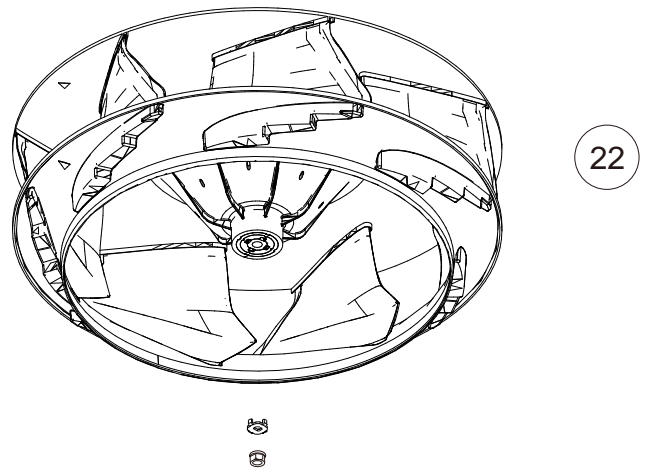
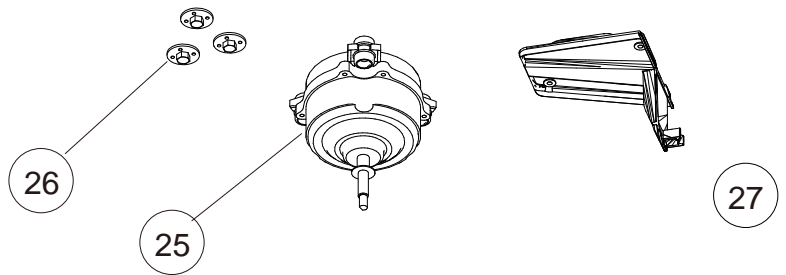
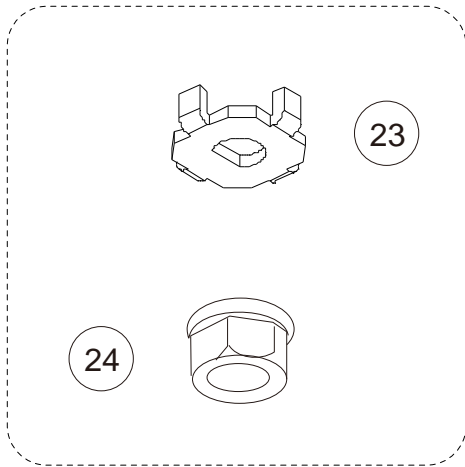
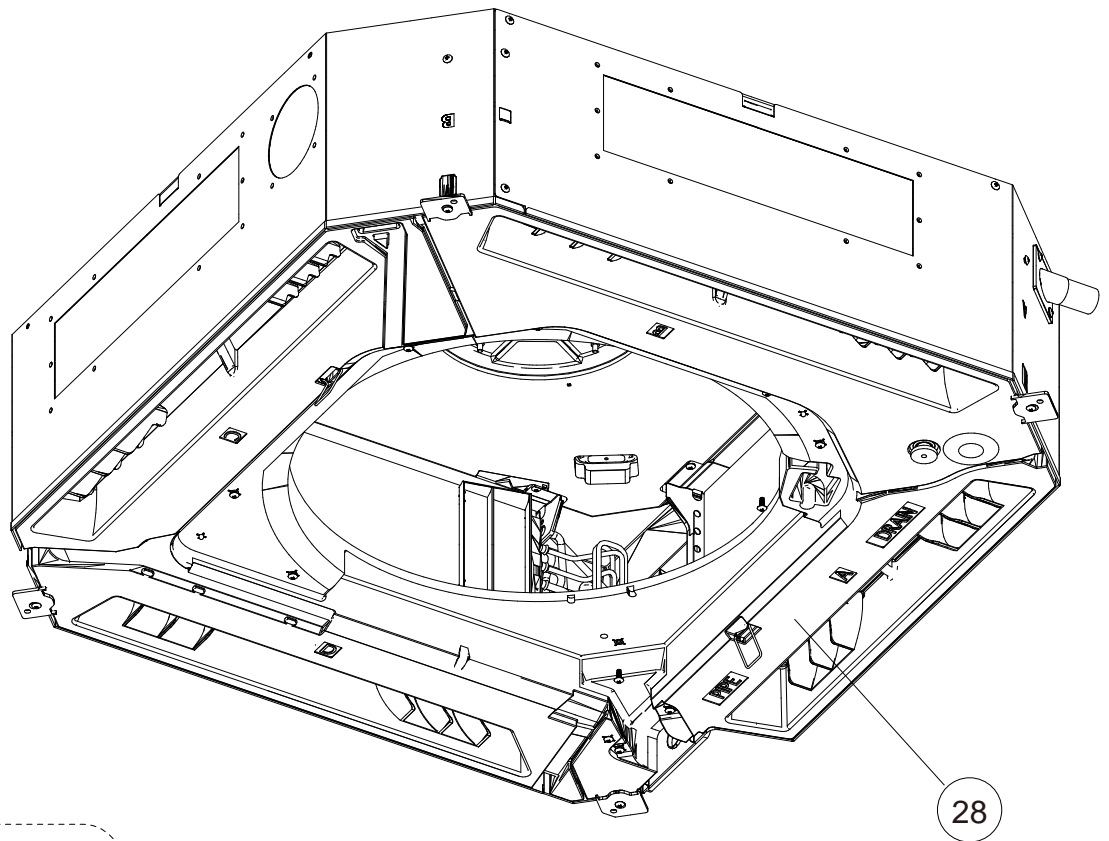

Ref.	Description	Part number
21	Bellmouth L (18, 24)	9381484010
21	Bellmouth H (30, 36, 42, 48)	9381345014
22	Turbo fan assy	9381303007
23	Turbo fan washer	9378394018
24	Nut	9356998009
25	Brushless motor	9603443009
26	Special nut	9378388017
27	Motor wire holder	9381351008
28	Drain pan sub assy	9381789009



INDOOR UNIT  
 AUU18RGLX  
 AUU24RGLX  
 AUU30RGLX  
 AUU36RGLX  
 AUU42RGLX  
 AUU48RGLX

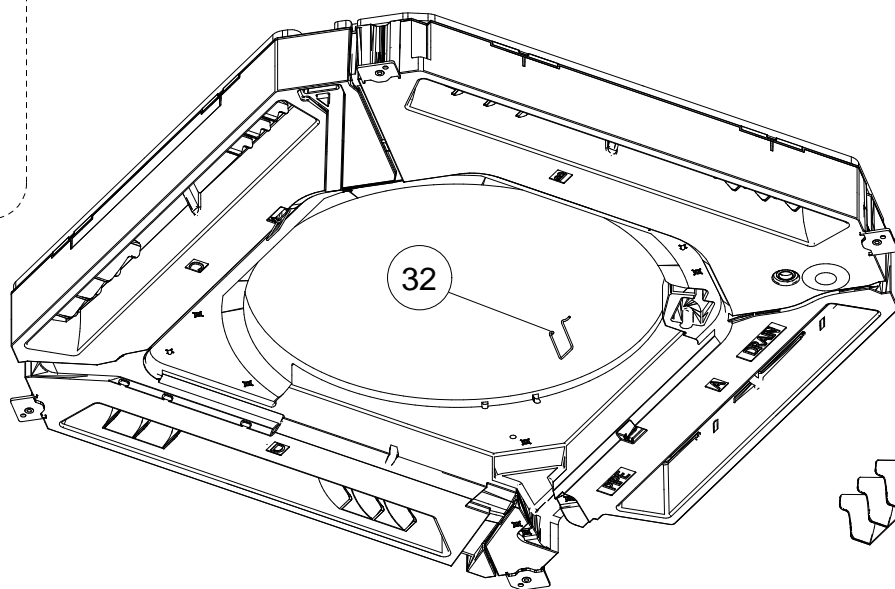
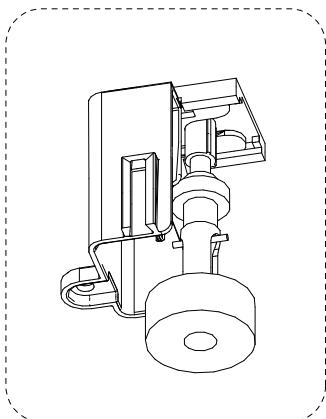
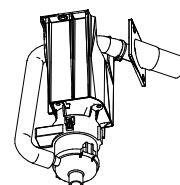
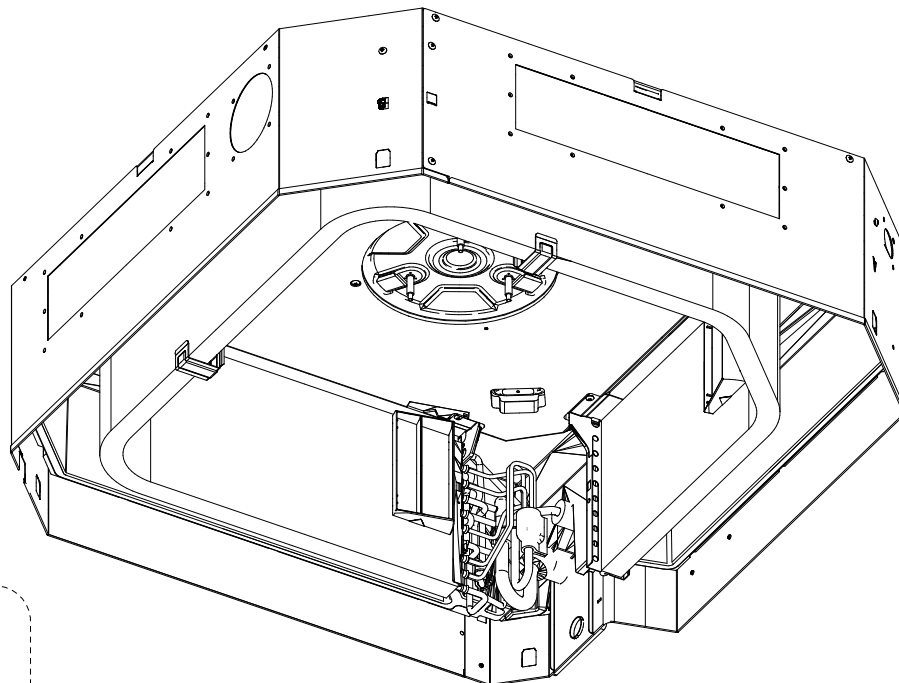

39

31

32

33

34

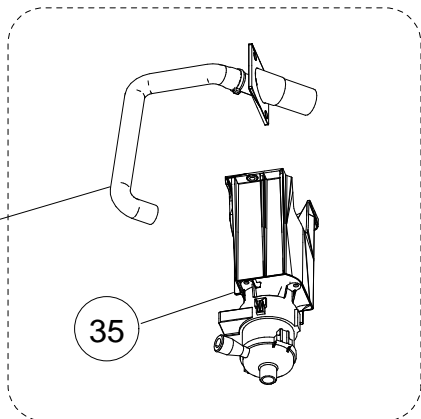

36

35

37

38

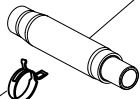

Ref.	Description	Part number
31	Drain cap	9375502010
32	Panel hook	9375671013
33	Vane L	9381745012
34	Vane R	9381744008
35	Drain pump sub assy	9381793006
36	Drain port sub assy	9381788002
37	Drain hose	9379665032
38	Hose band	9379757010
39	Float switch sub assy	9381794003

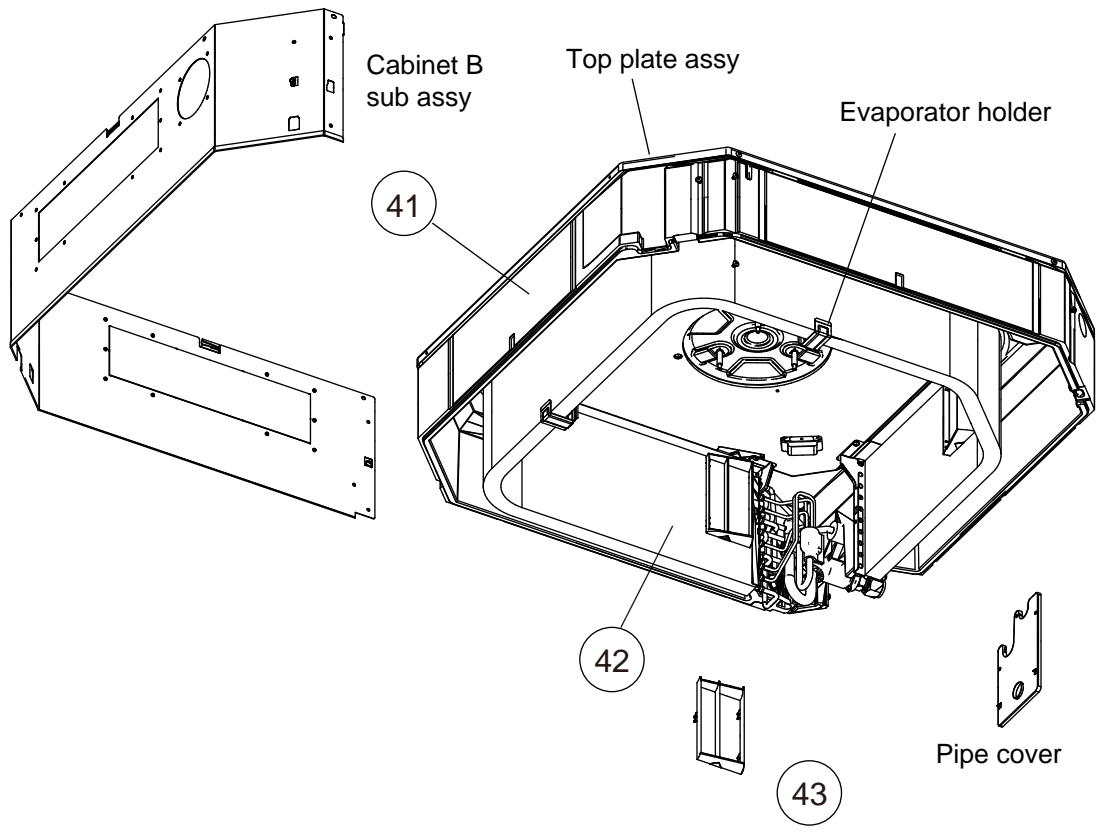

INDOOR UNIT  
AUU18RGLX  
AUU24RGLX

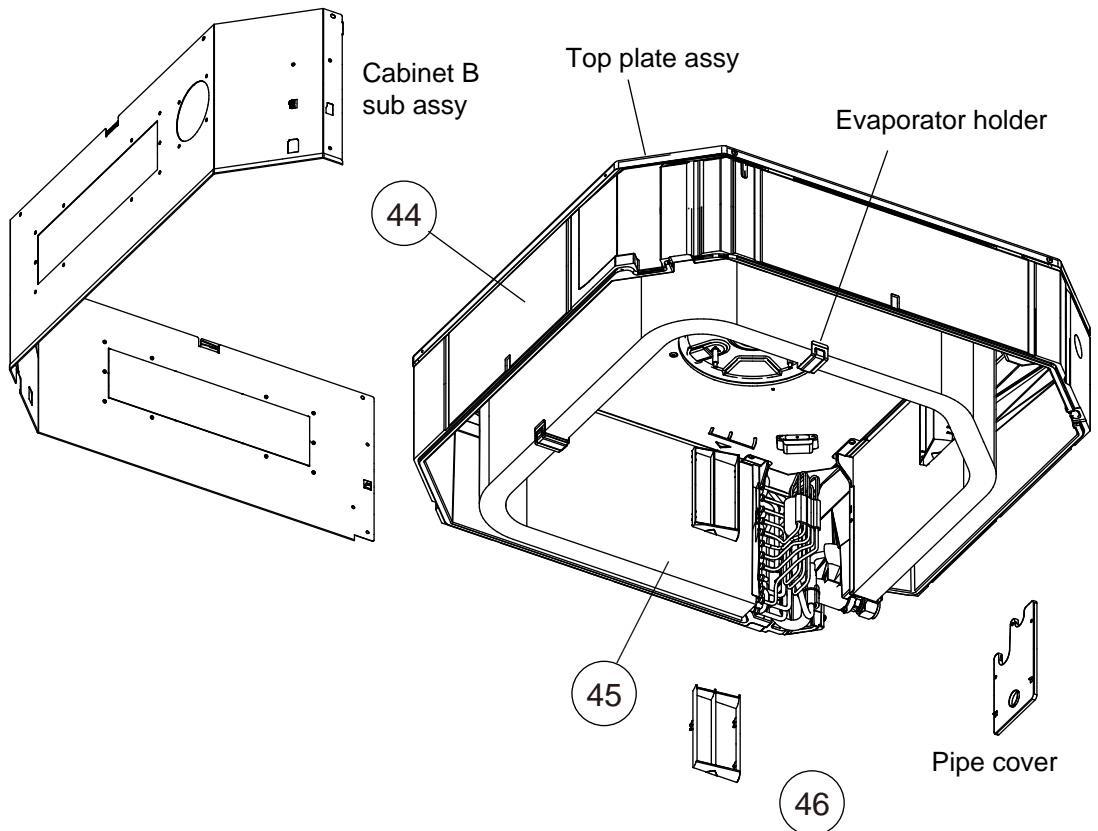
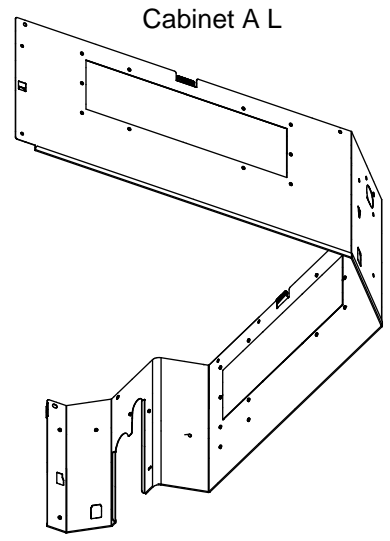

INDOOR UNIT  
AUU30RGLX  
AUU36RGLX  
AUU42RGLX  
AUU48RGLX

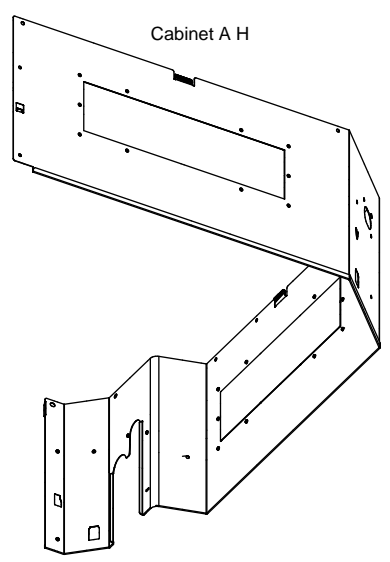

Ref.	Description	Part number
41	Insulation box sub assy	9381787012
42	Evaporator total assy (18) (complete)	9378580459
42	Evaporator total assy (24) (complete)	9378580442
43	Wind guide board	9382125004

Ref.	Description	Part number
44	Insulation box sub assy	9381787005
45	Evaporator total assy (30, 36) (complete)	9378580435
45	Evaporator total assy (42, 48) (complete)	9378580428
46	Wind guide board	9382125004

# PARTS

## OUTDOOR UNIT

AOU18RGLX  
AOU24RGLX  
AOU30RGLX  
AOU36RGLX

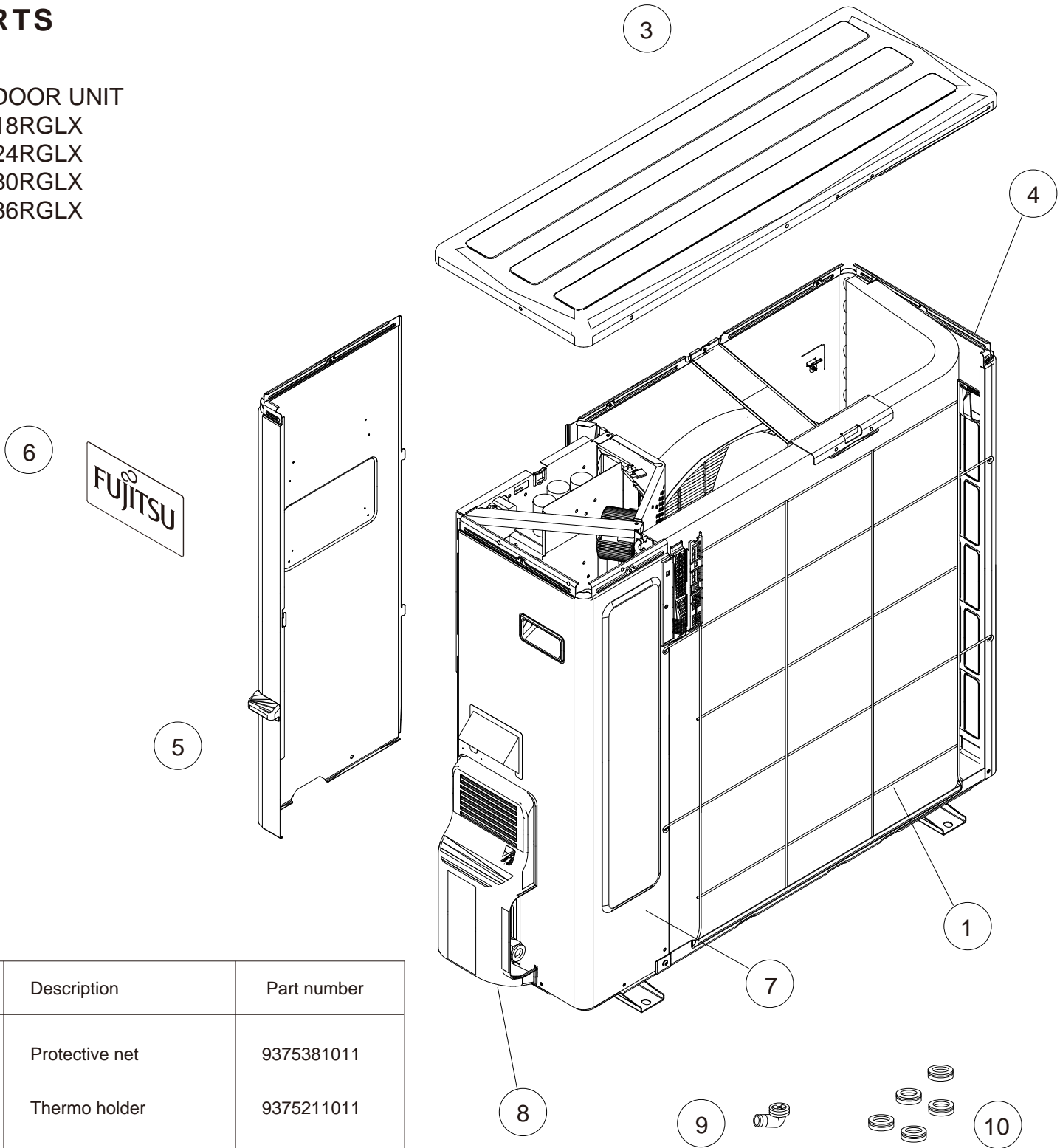

Ref.	Description	Part number
1	Protective net	9375381011
2	Thermo holder	9375211011
3	Top panel sub assy	9374417070
4	Front panel sub assy	9374414079
5	Service panel sub assy	9374415106
6	Rear emblem	9351355005
7	Right panel sub assy	9374416271
8	Valve cover	9374174010
9	Drain assy	9303029015
10	Drain cap	313166024302

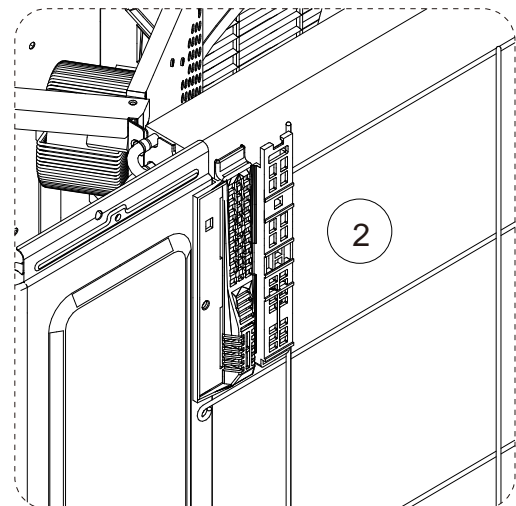

OUTDOOR UNIT  
 AOU18RGLX  
 AOU24RGLX  
 AOU30RGLX  
 AOU36RGLX

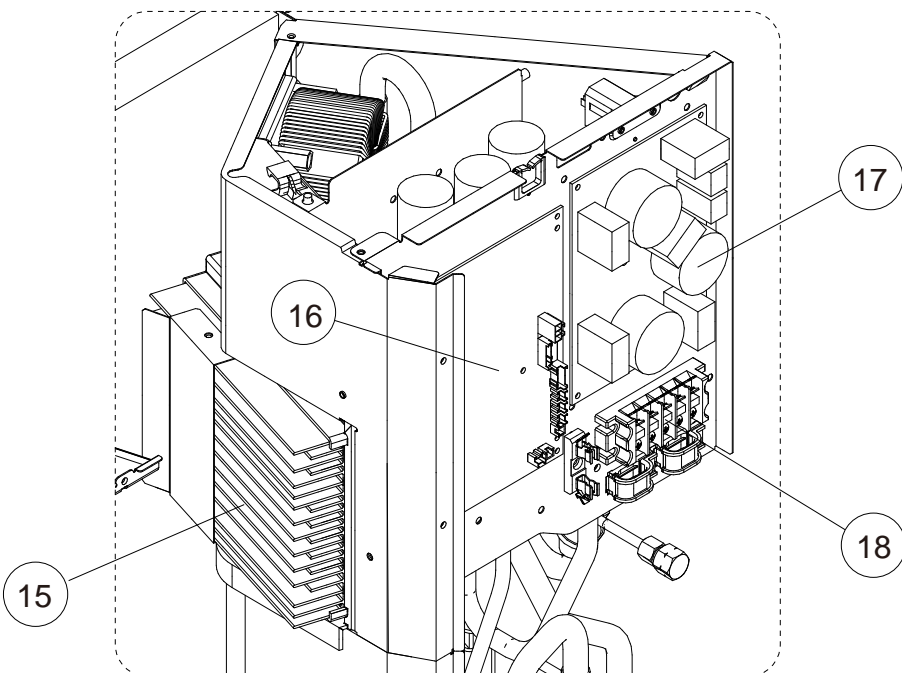
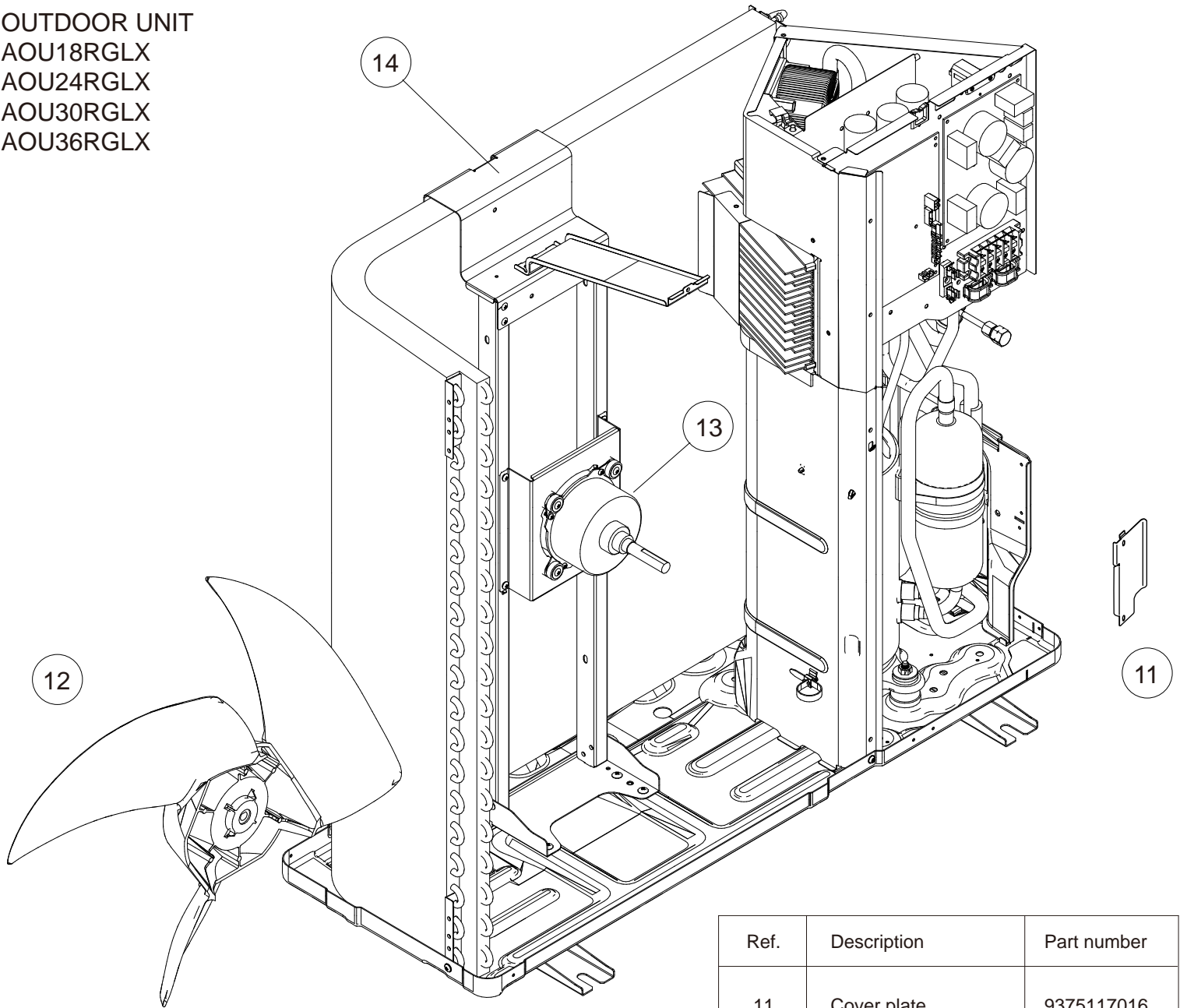

Ref.	Description	Part number
11	Cover plate	9375117016
12	Propeller fan assy	9366378020
13	Fan motor	9602843015
14	Motor bracket sub assy	9374418152
15	Heatsink	9378530010
16	Main PCB (AOU18)	9708511818
16	Main PCB (AOU24)	9708511825
16	Main PCB (AOU30)	9708511832
16	Main PCB (AOU36)	9708511849
17	Filter PCB (AOU18)	9708513065
17	Filter PCB (24, 30, 36)	9708513072
18	Terminal 5P	9900203023

OUTDOOR UNIT  
 AOU18RGLX  
 AOU24RGLX  
 AOU30RGLX  
 AOU36RGLX

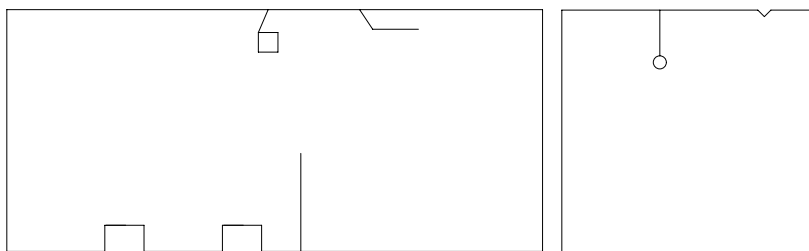
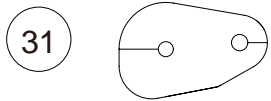
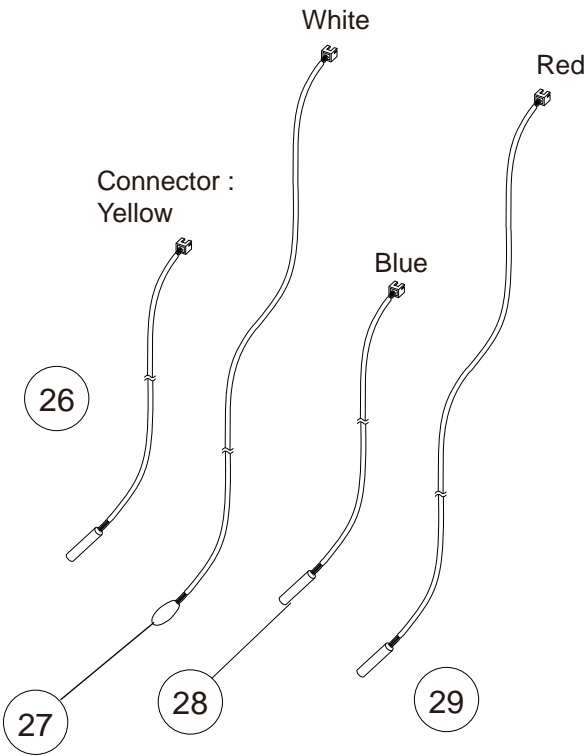
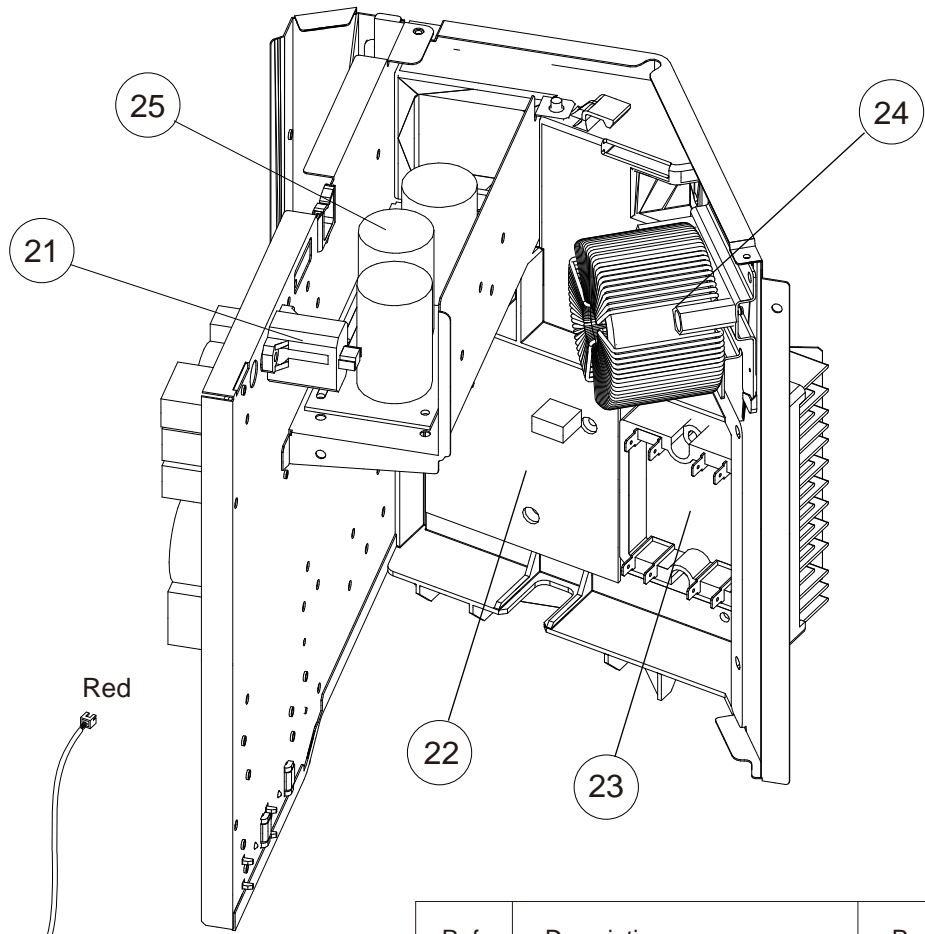

Ref.	Description	Part number
21	PTC thermistor (24, 30, 36)	9704265012
22	Transistor PCB (AOU18RGLX)	9708512174
22	Transistor PCB (24, 30, 36)	9708512181
23	ACTPM	9707592016
24	Choke coil	9900223014
25	Capacitor PCB (AOU18RGLX)	9709894033
25	Capacitor PCB (24, 30, 36)	9709894040
26	Discharge thermistor	9900461003
27	Thermistor (outdoor)	9900463007
28	Compressor thermistor	9900466015
29	Heat-exchanger thermistor	9900514013
30	Compressor cover A	9378851177
31	Compressor cover B	9378851283
32	Compressor cover C	9378851023
33	Compressor cover D	9378851184

OUTDOOR UNIT  
 AOU18RGLX  
 AOU24RGLX  
 AOU30RGLX  
 AOU36RGLX

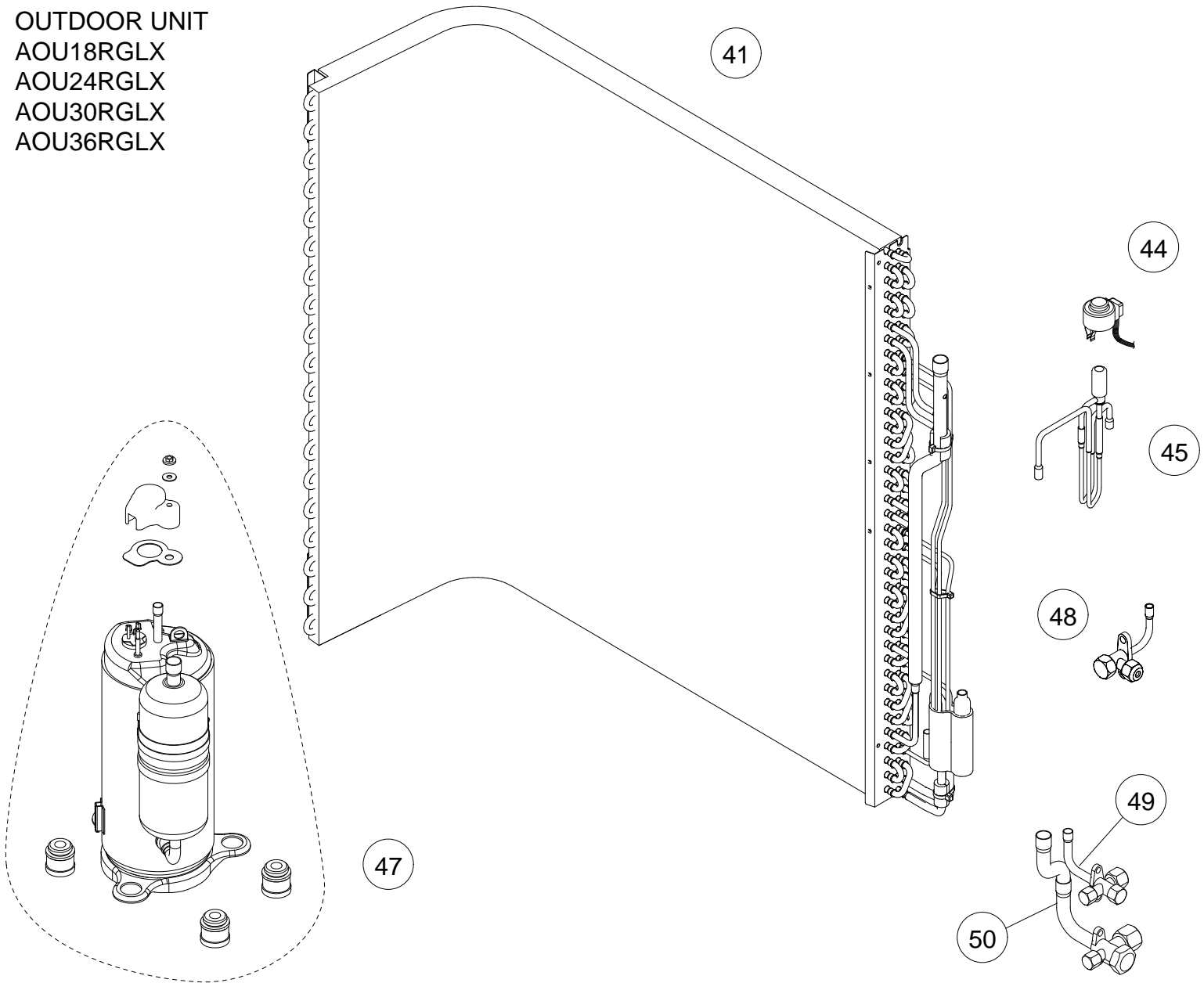

Ref.	Description	Part number
41	Condenser A sub assy (complete)	9374420308
42	Solenoid	9970055034
43	4-way valve assy	9374425198
44	Expansion valve coil	9970095030
45	Expansion valve assy (AOU18RGLX)	9370947168
45	Expansion valve assy (24, 30, 36)	9370947144
46	Accumulator sub assy	9374426133
47	Compressor	9810135001
48	2-way valve assy (AOU18RGLX)	9372204054
49	3-way valve assy (AOU24, 30, 36)	9377958013
50	3-way valve sub assy (AOU18RGLX)	9374470136
50	3-way valve sub assy (24, 30, 36)	9374470044

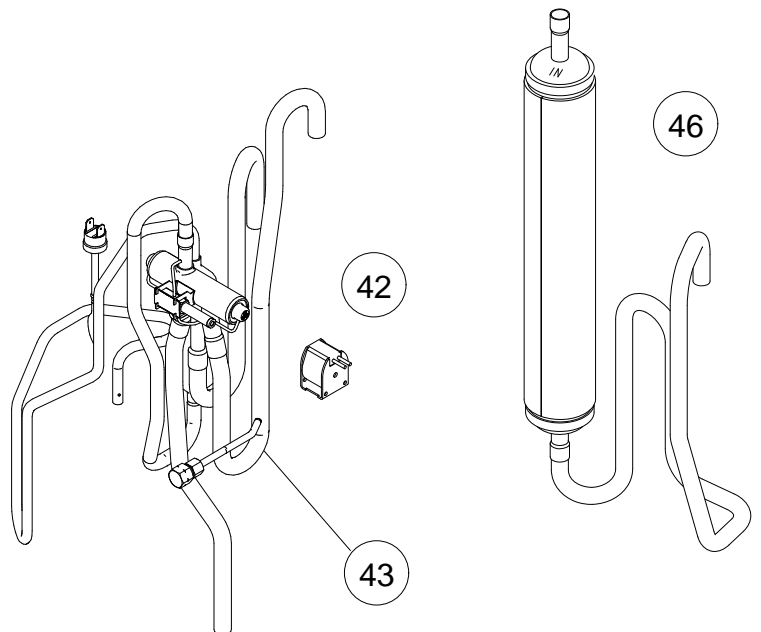

OUTDOOR UNIT  
 AOU42RGLX  
 AOU48RGLX

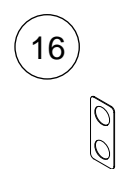
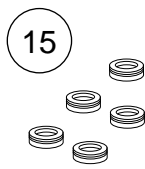
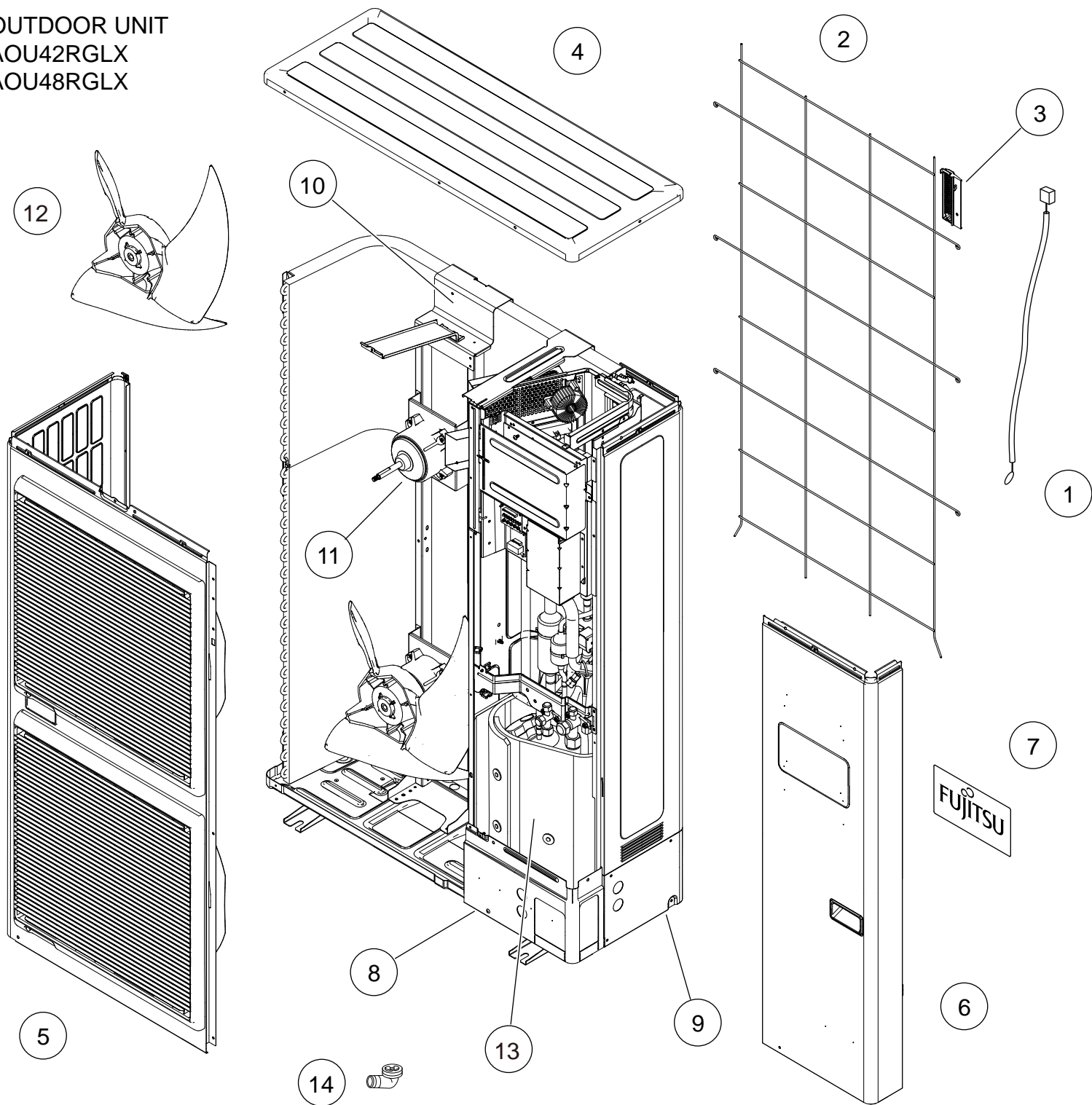

Ref.	Description	Part number
1	Outdoor thermistor	9900210069
2	Protective net	9375381042
3	Thermo holder	9375211011
4	Top panel sub assy	9374417087
5	Front panel sub assy	9374414154
6	Service panel sub assy	9374415113
7	Rear emblem	9351355005
8	Pipe cover front	9378861039

Ref.	Description	Part number
9	Right panel sub assy	9374416288
10	Motor bracket sub assy	9374418169
11	Motor DC brushless	9602843039
12	Propeller fan assy	9366378020
13	Compressor cover A	9378611078
14	Drain assy	9303029015
15	Drain cap	313166024302
16	Conduit plate	9379938006

OUTDOOR UNIT  
 AOU42RGLX  
 AOU48RGLX  
 Control box

Ref.	Description	Part number
21	Main PCB (42)	9709904541
21	Main PCB (48)	9709904534
22	Indicator PCB	9708678016
23	Terminal	9900428020
24	Filter PCB (42)	9709903063
24	Filter PCB (48)	9709903087
25	Thermistor	9704265012
26	Capacitor PCB	9709894132
27	Choke Coil	9900624019
28	ACTPM	9707592016
29	Transistor PCB	9711285034
30	Heatsink (42)	9380358022
30	Heatsink Assy (48)	9383694004

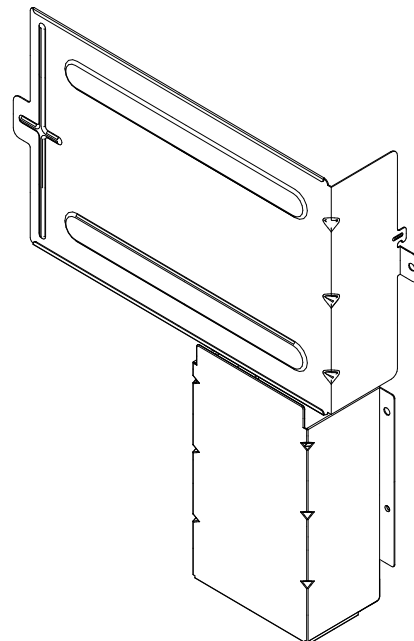
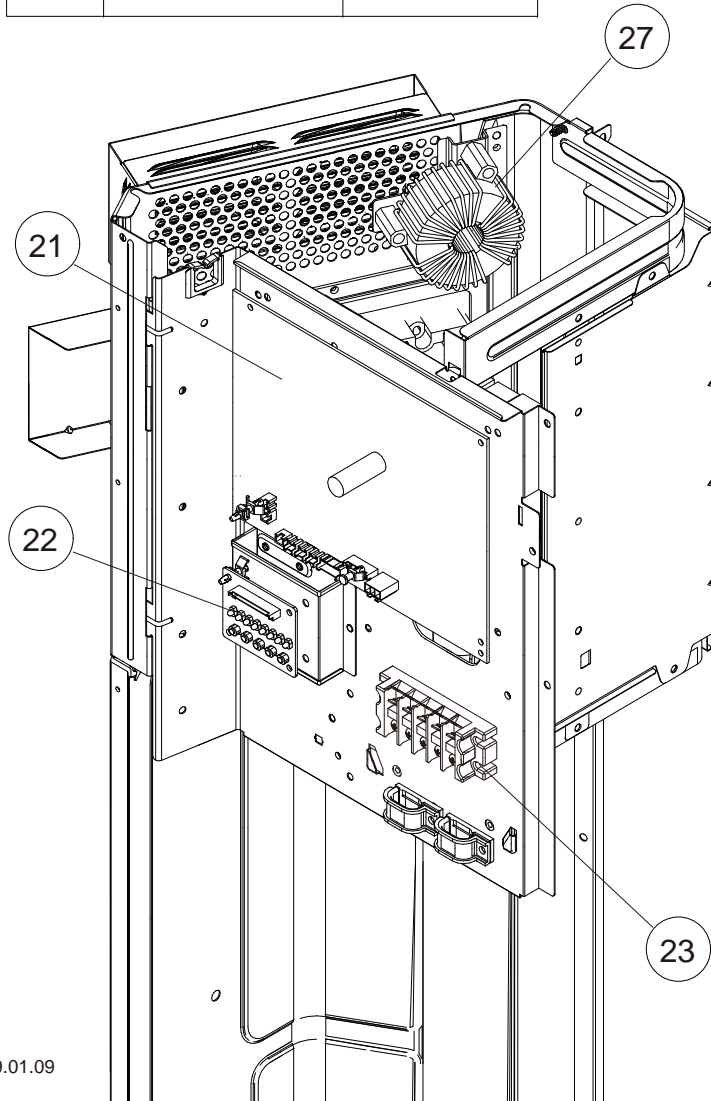
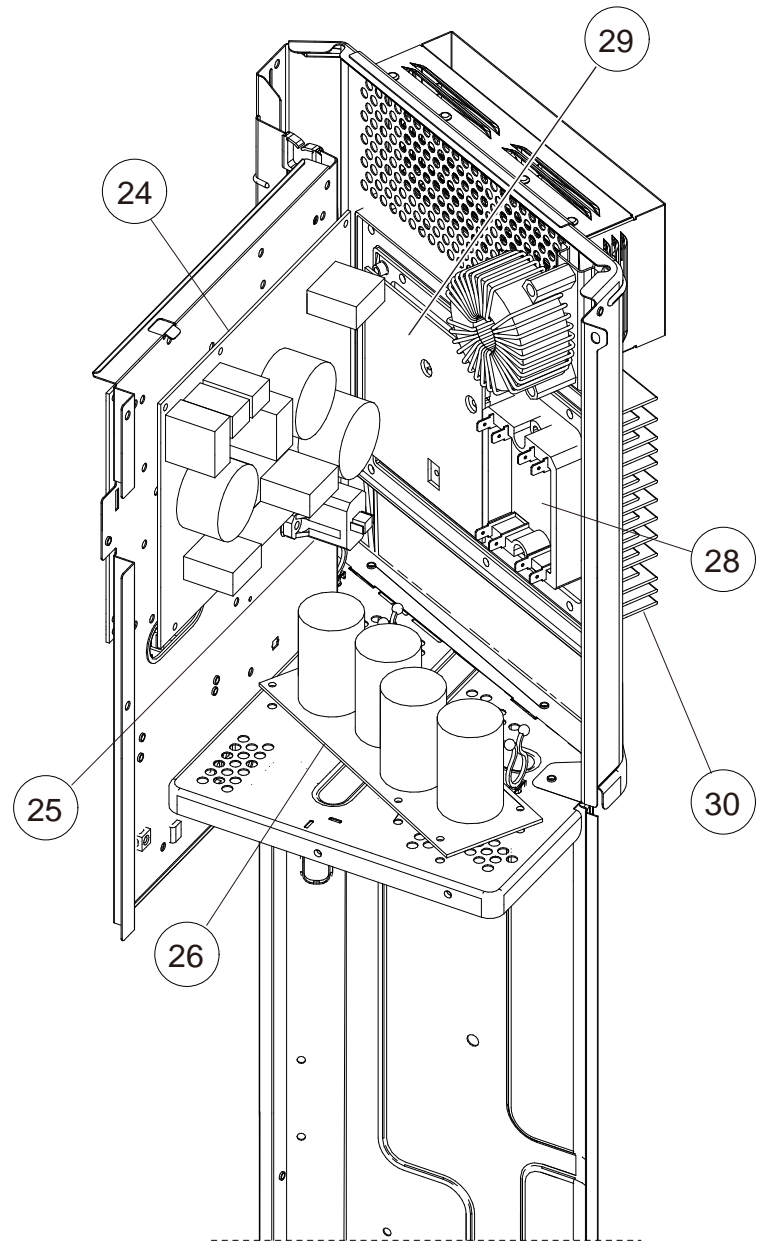



OUTDOOR UNIT  
 AOU42RGLX  
 AOU48RGLX

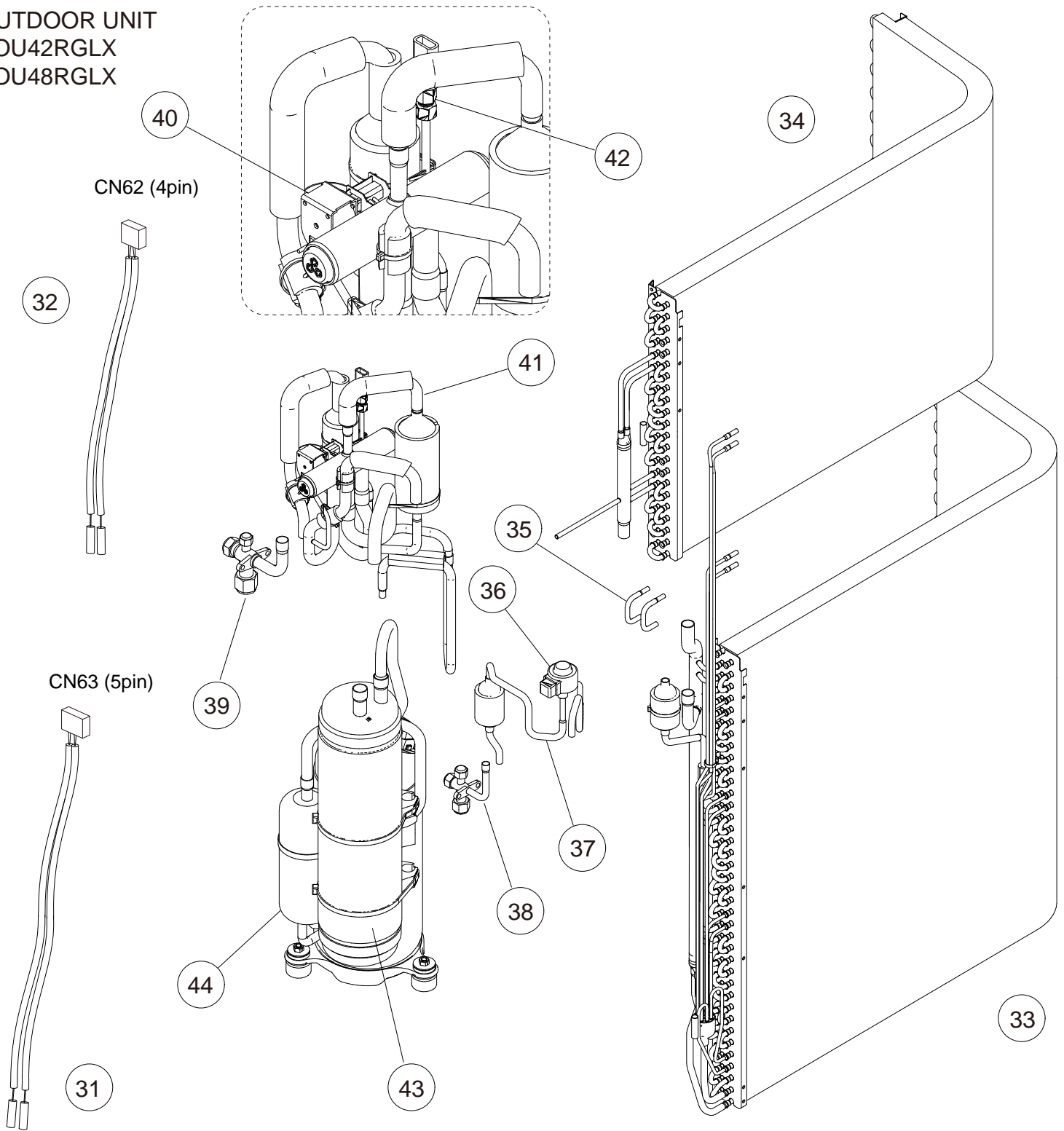









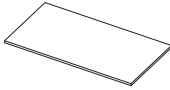

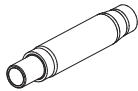
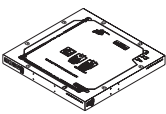
Ref.	Description	Part number
31	Thermistor assy (5 pins)	9900599027
32	Thermistor assy (4 pins)	9900598013
33	Condenser A sub assy (complete)	9374420261
34	Condenser B sub assy (complete)	9374422081
35	Bypass pipe A	9371324043
36	Expansion valve coil	9970098062
37	Expansion Valve Assy	9370947182

Ref.	Description	Part number
38	3-way valve aassy	9379077002
39	3-way valve assy	9379079006
40	Solenoid	9970113055
41	4-way valve assy	9374425525
42	Sensor	9970178023
43	Accumulator assy	9375250096
44	Compressor sub assy	9374423460



# Accessories

## INDOOR UNIT

Part name	Exterior	Q'ty	Part name	Exterior	Q'ty
Installation manual		1	Insulation		1
Operating manual		1	Drain hose		1
Template (Carton top)		1	Hose band		1
Washer		8	Drain hose heat insulation		1
Coupler heat insulation (Large)		1	Cable tie (Large)		4
Coupler heat insulation (Small)		1	Cable tie (Small)		2

# Optional parts

## 1. Controllers

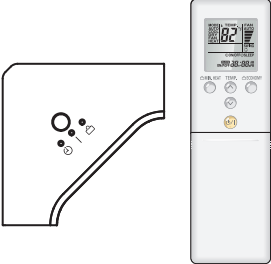

Exterior	Part name	Model name	Summary
	Wired remote controller	UTY-RNRUZ*	Easy finger touch operation with LCD panel. Backlit LCD enables easy operation in a dark room. Wire type: Non-polar 2-wire
	Simple remote controller	UTY-RSRY	Compact remote controller concentrates on the basic functions such as Start/Stop, fan control, temperature setting, and operation mode. Wire type: Non-polar 2-wire
	Simple remote controller	UTY-RHRY	Compact remote controller concentrates on the basic functions such as Start/Stop, fan control, and temperature setting. Wire type: Non-polar 2-wire
	IR receiver kit with wireless remote controller	UTY-LBTUC	Unit control is performed by wireless remote controller.

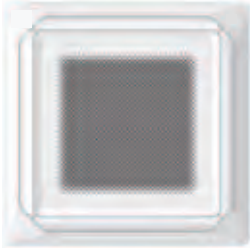
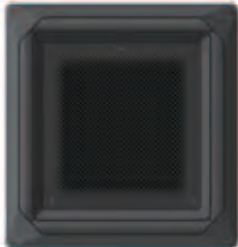

**NOTE:** Available functions may differ by the remote controller. For details, refer to the operation manual.

## 2. Cassette grille

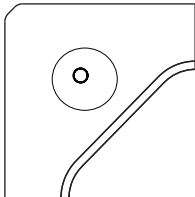
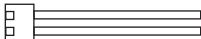
Exterior	Part name	Model name	Summary
	Cassette grille	UTG-GCGF	This cassette grille to blow airflow in 360° direction by unique seamless airflow louver design.
	Cassette grille	UTG-LCGVCB	This cassette grille to blow airflow in 360° direction by unique seamless airflow louver design. Black color model.

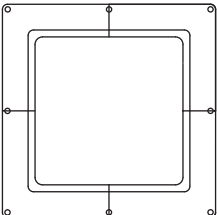
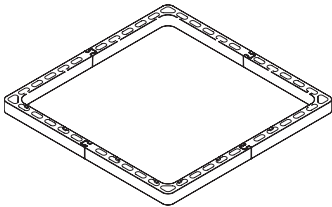
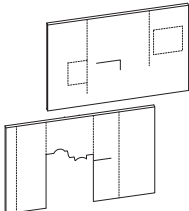
## 3. Others

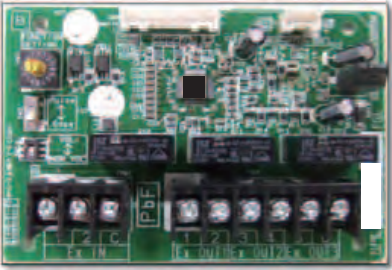
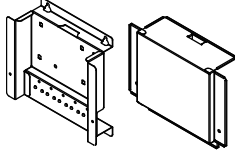
Exterior	Part name	Model name	Summary
	Human sensor kit	UTY-SHZXC	For circular flow cassette type.
	External connect kit	UTY-XWZXZG	Use to connect with various peripheral devices and air conditioner PCB. For control output port.
	Air outlet shutter plate	UTR-YDZK	Installed at the air outlet when 3-directions mode is performed.
	Wide panel	UTG-AKXA-W	Hides the gap between the ceiling hole and the cassette grille.
	Panel spacer	UTG-BKXA-W	If there is not enough height in the ceiling space, by inserting this spacer between the cassette grille and the ceiling surface, the height of the unit body goes into the ceiling space become 50-mm lower.
	Insulation for high humidity	UTZ-KXRA	Install when the under-roof condition is expected to be the humidity of over 80% and the temperature of over 86 °F(30 °C).

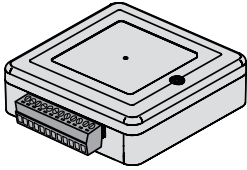

Exterior	Part name	Model name	Summary
	External input and output PCB	UTY-XCSX	Use to connect with external devices and air conditioner PCB.
	External input and output PCB box	UTZ-GXRA	For installing the External input and output PCB.
	Wireless LAN adapter	UTY-TFSXZ2	Remotely manage an air conditioning system using mobile devices such as smartphones and tablets.
	Thermostat converter	UTY-TTRX	This converter can control Fujitsu General products using a third-party thermostat controller.

**NOTE:** Combined use of following optional parts and Wireless LAN adapter (UTY-TFSXZ2) is not allowed.



- External input and output PCB (UTY-XCSX)
- Thermostat converter

## Accessories

### Models: AOU18RGLX, AOU24RGLX, AOU30RGLX, and AOU36RGLX

Part name	Exterior	Q'ty	Part name	Exterior	Q'ty
Installation manual		1	Drain cap		5
Drain pipe		1			

### Models: AOU42RGLX and AOU48RGLX

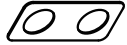
Part name	Exterior	Q'ty	Part name	Exterior	Q'ty
Installation manual		1	Drain cap		5
Drain pipe		1	Conduit plate		1

# Optional parts

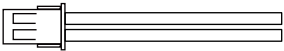
Exterior	Part name	Model name	Summary
	External connect kit	UTY-XWZXZ3	Use to operate the external input and output functions of outdoor unit. For 42/48 model

1807G4738