

**INDOOR UNIT**

**1. WALL MOUNTED TYPE :**

**ASU18RL**

**ASU18CL**

# 1. FEATURE

■ **MODEL : ASU18RL  
ASU18CL**



## ■ FEATURES

### ● ALL DC

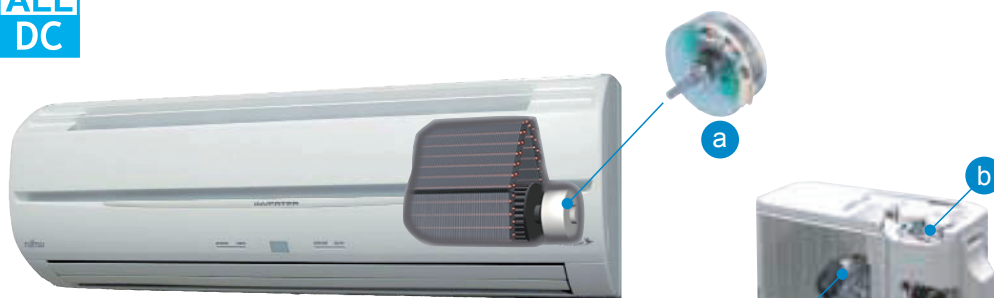

- a DC fan motor**
- b V-PAM control**  
V-PAM technology makes a compressor more powerful.
- c DC rotary compressor**  
More compact compared with conventional model

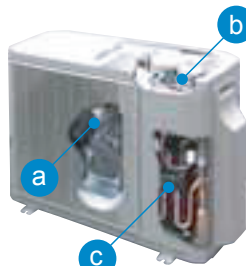

Front view

### ● Super quiet

Air flow mode can be set in 4 steps and more detailed air flow setting is possible.

### ● Air conditioner filter features



## ● Easy maintenance

Easy maintenance and always clean. Troublesome maintenance has been made easy.

Since the front panel is easy to remove, maintenance is also easy.

## ● Inner drying operation

This model is equipped with an inner drying function. After the power is turned off, the dry operation starts inside the air conditioner. This prevents the growth of mold and bacteria inside the air conditioner.

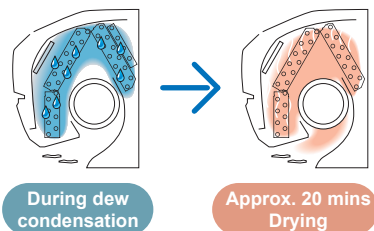

## ● Low outdoor air temperature cooling correspondence

Corresponds to cooling operation at 14°F(-10°C) outdoor air temperature

## ● Corresponds to maximum 66ft.(20m) long piping

## 2. REMOTE CONTROLLER

### 2-1. WIRELESS REMOTE CONTROLLER

#### ■ FEATURES

\* Four kinds of timer setup (ON / OFF / PROGRAM / SLEEP) are possible.

\* Four kinds of timers. Easy operation.

#### ● Built-in timers

Select from four different timer programs (On/Off/Program/Sleep).

#### ● Program timer

The program timer operates the ON and OFF timer once within a 24 hour period.

#### ● Sleep timer

The sleep timer function automatically corrects the temperature thermostat setting according to the time setting to prevent excessive cooling and heating(\*) while sleeping.

##### Cooling operation/dry operation

When the sleep timer is set, the set temperature automatically rises 2 °F every hour. The set temperature can rise up to a maximum of 4 °F.

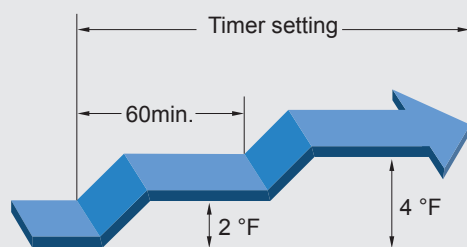

##### Heating operation(\*)

When the sleep timer is set, the set temperature automatically drops 2 °F every 30 minutes. The set temperature can drop to a maximum of 8 °F.

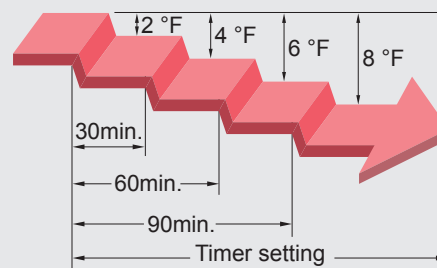

(\*) : Heat pump model only.

## FUNCTIONS (Heat pump model)

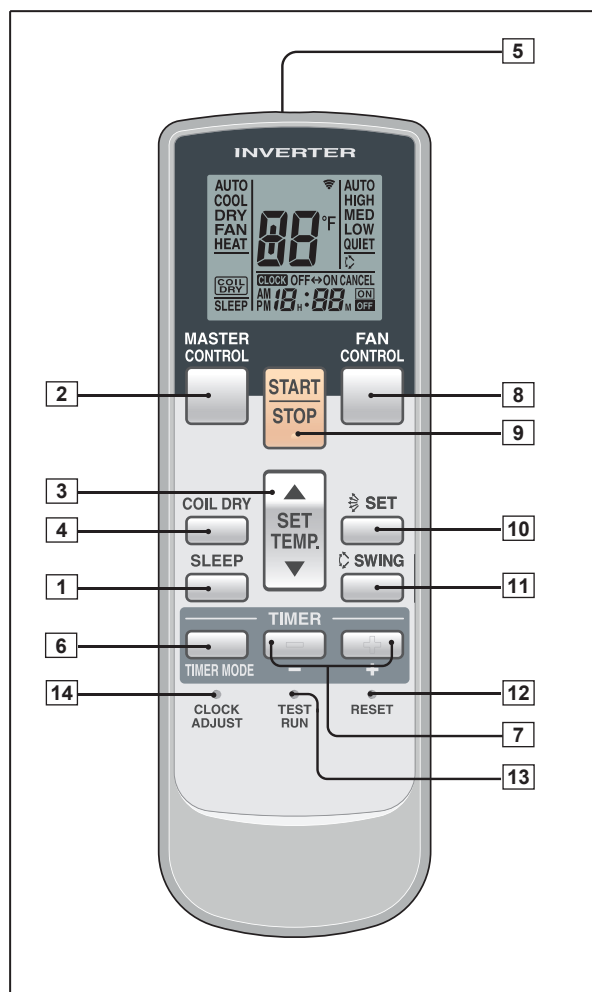

- 1 SLEEP button
- 2 MASTER CONTROL button
- 3 SET TEMP button ( ▲ / ▼ )
- 4 COIL DRY button
- 5 Signal Transmitter
- 6 TIMER MODE button
- 7 TIMER SET ( + / - ) button
- 8 FAN CONTROL button
- 9 START/STOP button
- 10 SET button
- 11 SWING button
- 12 RESET button
- 13 TEST RUN button
  - This button is used when installing the conditioner, and should not be used under normal conditions, as it will cause the air conditioner's thermostat function to operate incorrectly.
  - If this button is pressed during normal operation, the unit will switch to test operation mode, and the Indoor Unit's OPERATION Indicator Lamp and TIMER Indicator Lamp will begin to flash simultaneously.
  - To stop the test operation mode, press the START/STOP button to stop the air conditioner.

### Display panel

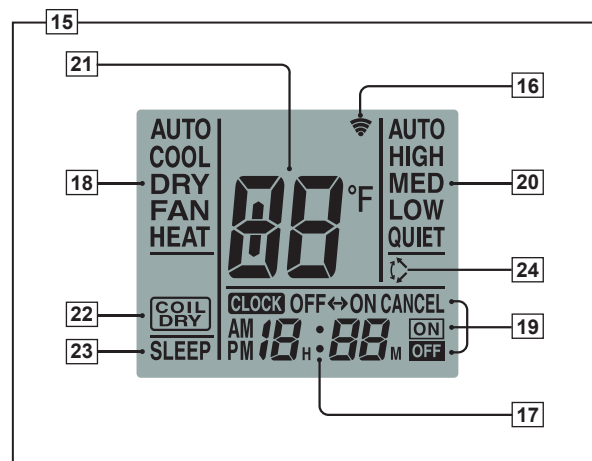

- 14 CLOCK ADJUST button
- 15 Remote Control Unit Display
- 16 Transmit Indicator
- 17 Clock Display
- 18 Operating Mode Display
- 19 Timer Mode Display
- 20 Fan Speed Display
- 21 Temperature SET Display
- 22 COIL DRY Display
- 23 SLEEP Display
- 24 SWING Display

## SPECIFICATION

SIZE [H x W x D in. (mm)]	6-15/16 x 2-7/32 x 23/32 (176 x 56 x 18)
WEIGHT oz. (g)	3.9 (110)
ACCESSORY	Holder

## FUNCTIONS (Cooling only model)

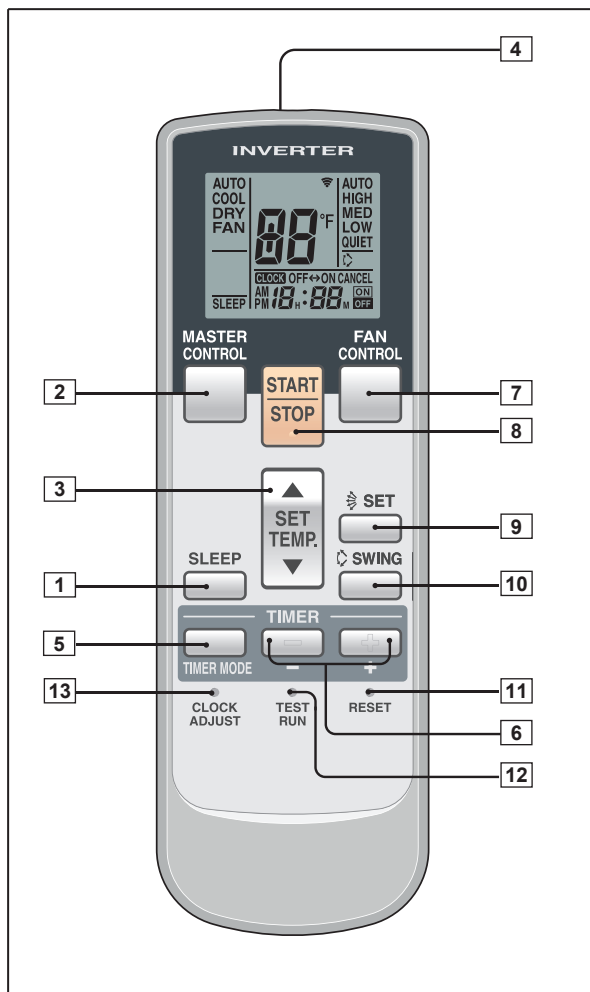

- 1 SLEEP button
- 2 MASTER CONTROL button
- 3 SET TEMP. button ( ▲ / ▼ )
- 4 Signal Transmitter
- 5 TIMER MODE button
- 6 TIMER SET ( + / - ) button
- 7 FAN CONTROL button
- 8 START/STOP button
- 9 SET button
- 10 SWING button
- 11 RESET button
- 12 TEST RUN button
  - This button is used when installing the conditioner, and should not be used under normal conditions, as it will cause the air conditioner's thermostat function to operate incorrectly.
  - If this button is pressed during normal operation, the unit will switch to test operation mode, and the Indoor Unit's OPERATION Indicator Lamp and TIMER Indicator Lamp will begin to flash simultaneously.
  - To stop the test operation mode, press the START/STOP button to stop the air conditioner.

- 13 CLOCK ADJUST button
- 14 Remote Control Unit Display
- 15 Transmit Indicator
- 16 Clock Display
- 17 Operating Mode Display
- 18 Timer Mode Display
- 19 Fan Speed Display
- 20 Temperature SET Display
- 21 SLEEP Display
- 22 SWING Display

Display panel

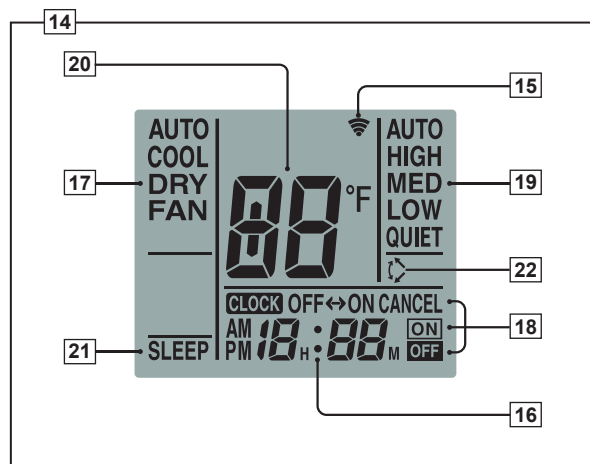

## SPECIFICATION

SIZE [H x W x D in. (mm)]	6-15/16 x 2-7/32 x 23/32 (176 x 56 x 18)
WEIGHT oz. (g)	3.9 (110)
ACCESSORY	Holder

### 3. SPECIFICATIONS

Type			WALL MOUNTED				
			INVERTER HEAT PUMP	INVERTER COOLING ONLY			
Model name			ASU18RL	ASU18CL			
Power source			208/230V~ 60Hz				
Available voltage range			187-253V~ 60Hz				
Capacity	Cooling	Rated	kW	5.28	5.28		
			BTU/h	18,000	18,000		
		Min-Max	kW	1.62 - 5.58	1.62 - 5.58		
			BTU/h	5,500 - 19,000	5,500 - 19,000		
	Heating	Rated	kW	6.30	—		
			BTU/h	21,600	—		
Min-Max		kW	1.32 - 8.52	—			
		BTU/h	4,600 - 29,000	—			
Input power	Cooling	Rated	kW	1.73	1.73		
				Min-Max	0.25 - 2.00	0.25 - 2.00	
	Heating	Rated	kW	1.93	—		
				Min-Max	0.25 - 2.93	—	
		Current	Cooling	Rated	A	7.7	7.7
						Max	9.0
Heating	Rated		A	8.6	—		
				Max	13.5	—	
EER	Cooling	kW/kW	3.05	3.05			
			BTU/hW	10.40	10.40		
COP	Heating	kW/kW	3.28	—			
			BTU/hW	11.20	—		
SEER	Cooling	BTU/hW	19.00	19.00			
HSPF	Heating	BTU/hW	10.00	—			
SENSIBLE CAPACITY	Cooling	kW	3.37	3.37			
			BTU/h	11,500	11,500		
POWER FACTOR	Cooling	%	98	98			
	Heating		98	—			
Moisture removal			pints/h(l/h)	5.9 (2.8)			
Fan	Airflow rate	Cooling	High	412 (700)	412 (700)		
			Med	341 (580)	341 (580)		
			Low	271 (460)	271 (460)		
			Quiet	218 (370)	218 (370)		
		Heating	High	412 (700)	—		
			Med	353 (600)	—		
			Low	294 (500)	—		
			Quiet	247 (420)	—		
	Type × Qty			Cross flow fan×1			
	Motor output			W	42		
Sound pressure level	Cooling	dB(A)	High	44	44		
			Med	38	38		
			Low	32	32		
			Quiet	25	25		
	Heating	dB(A)	High	42	—		
			Med	37	—		
			Low	32	—		
			Quiet	27	—		
Heat exchanger type	Dimensions (H × W × D)		in. (mm)	MAIN : 13-7/32 x 25 x 1-1/16 (336×635×26.6) SUB : 3-5/16 x 25 x 17/32 (84×635×13.3)			
	Fin pitch		FPI	Main:21, Sub:18			
	Rows x Stages			Main:2×16, Sub:1×4			
	Pipe type			Copper			
	Fin type			Aluminum			
Enclosure	Material		Polystyrene				
	Color		White				
Dimensions (H×W×D)	Net	mm	275×790×215				
		inch	10-13/16×31-1/8×8-7/16				
	Gross	mm	290×835×345				
		inch	11-13/32×32-7/8×13-19/32				
Weight	Net	lb.(kg)	20 ( 9 )				
	Gross		26 ( 12 )				
Connection pipe	Size	Liquid	in.(mm)	Φ1/4 (Φ6.35)			
		Gas		Φ1/2 (Φ12.7)			
	Method		Flare				
Operation range	Cooling	°F(°C)	64 to 90 (18 to 32)				
		%RH	80 or less				
	Heating	°F(°C)	88 (30) or less	—			
Remote controller type			Wireless				
Drain pipe	Material		PP + LLDPE				
	Size		mm (Reference in.)	Outer diameter: 29 (1-5/32) Inner diameter: 16 (5/8)			

Note :  
Specifications are based on the following conditions.  
Cooling : Indoor temperature of 80°F(26.67°C)DB/67°F(19.44°C)WB, and outdoor temperature of 95°F(35°C)DB/75°F(23.9°C)WB.  
Heating : Indoor temperature of 70°F(21.11°C)DB/59°F(15°C)WB, and outdoor temperature of 47°F(8.33°C)DB/43°F(6.11°C)WB.  
Pipe length : 24ft.7in.(7.5 m), Height difference : 0 m. (Outdoor unit - Indoor unit)

## 4. DIMENSIONS

■ MODEL : ASU18RL, ASU18CL

Unit : inch (mm)

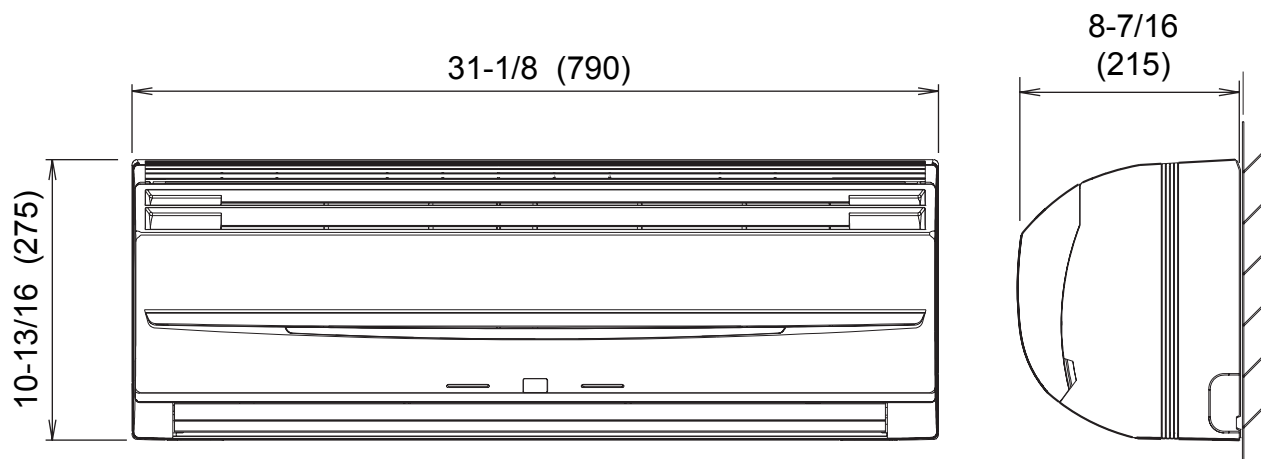

## ■ INSTALLATION PLACE

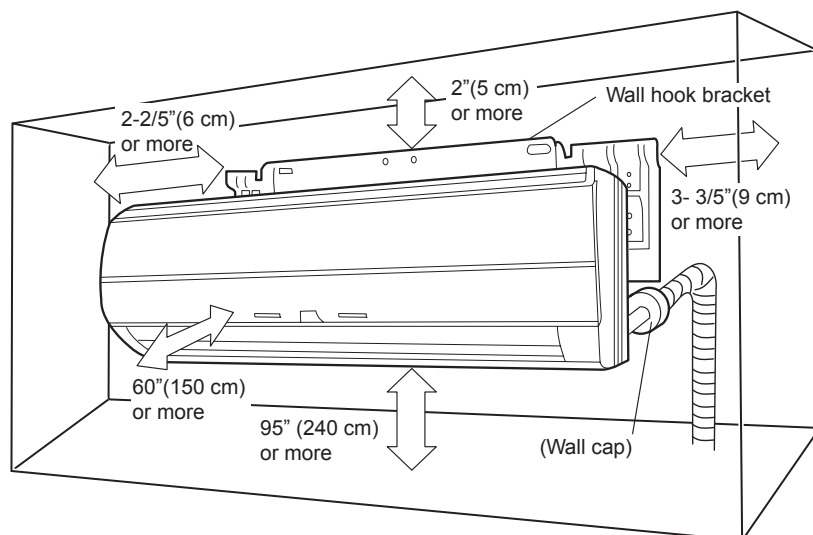



# 5. WIRING DIAGRAMS

■ MODEL : ASU18RL, ASU18CL

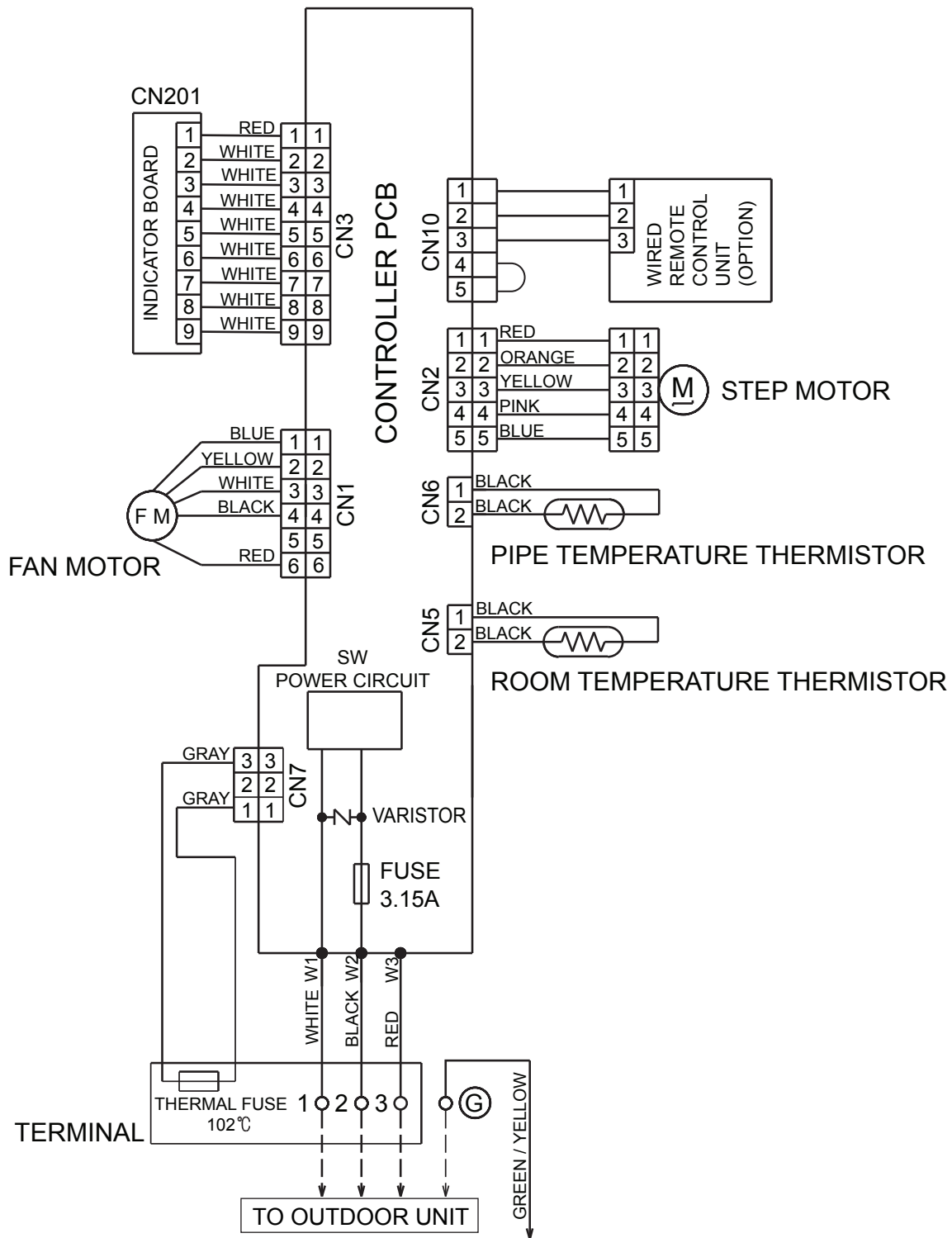

## 6. CAPACITY TABLE

### 6-1. COOLING CAPACITY

#### ■ MODEL : ASU18RL ASU18CL

AFR	412
-----	-----

		Indoor temperature																	
		64°FDB			70°FDB			75°FDB			80°FDB			85°FDB			90°FDB		
		54°FWB			60°FWB			63°FWB			67°FWB			71°FWB			73°FWB		
Outdoor temperature	°FDB	TC	SHC	PI	TC	SHC	PI	TC	SHC	PI	TC	SHC	PI	TC	SHC	PI	TC	SHC	PI
	67	13.3	9.1	0.82	14.9	9.2	0.84	16.4	10.0	0.85	16.9	10.8	0.85	17.9	10.7	0.86	18.9	11.4	0.87
	77	15.9	10.8	1.37	17.7	10.9	1.39	19.5	11.9	1.41	20.1	12.8	1.42	21.3	12.8	1.43	22.5	13.6	1.45
	87	15.2	10.4	1.52	17.0	10.4	1.54	18.7	11.4	1.56	19.3	12.3	1.57	20.4	12.2	1.59	21.6	13.0	1.60
	95	14.2	9.7	1.67	15.9	9.8	1.70	17.5	10.6	1.72	18.0	11.5	1.73	19.1	11.5	1.75	20.2	12.2	1.76
	104	12.8	8.8	1.68	14.3	8.8	1.71	15.8	9.6	1.73	16.3	10.4	1.74	17.2	10.3	1.76	18.2	11.0	1.78
	115	12.0	8.2	1.69	13.4	8.2	1.72	14.7	9.0	1.75	15.2	9.7	1.76	16.1	9.7	1.77	17.0	10.3	1.79

AFR : Air Flow Rate (CFM)  
 TC : Total Capacity (kBTU)  
 SHC : Sensible Heat Capacity (kBTU)  
 PI : Power Input (kW)

AFR	11.7
-----	------

		Indoor temperature																	
		17.8°CDB			21.1°CDB			23.9°CDB			26.7°CDB			29.4°CDB			32.2°CDB		
		12.2°CWB			15.6°CWB			17.7°CWB			19.4°CWB			21.7°CWB			22.8°CWB		
Outdoor temperature	°CDB	TC	SHC	PI	TC	SHC	PI	TC	SHC	PI	TC	SHC	PI	TC	SHC	PI	TC	SHC	PI
	19.4	3.91	2.67	0.82	4.36	2.68	0.84	4.80	2.93	0.85	4.95	3.16	0.85	5.25	3.15	0.86	5.54	3.35	0.87
	25.0	4.66	3.18	1.37	5.19	3.20	1.39	5.72	3.49	1.41	5.90	3.76	1.42	6.25	3.75	1.43	6.61	3.99	1.45
	30.6	4.46	3.04	1.52	4.97	3.06	1.54	5.48	3.34	1.56	5.65	3.60	1.57	5.98	3.59	1.59	6.32	3.82	1.60
	35.0	4.17	2.84	1.67	4.65	2.86	1.70	5.12	3.12	1.72	5.28	3.37	1.73	5.60	3.36	1.75	5.91	3.58	1.76
	40.0	3.76	2.57	1.68	4.19	2.58	1.71	4.62	2.82	1.73	4.77	3.04	1.74	5.05	3.03	1.76	5.34	3.23	1.78
	46.1	3.52	2.40	1.69	3.92	2.41	1.72	4.32	2.63	1.75	4.45	2.84	1.76	4.72	2.83	1.77	4.99	3.02	1.79

AFR : Air Flow Rate (m<sup>3</sup>/min)  
 TC : Total Capacity (kW)  
 SHC : Sensible Heat Capacity (kW)  
 PI : Power Input (kW)

# 6-2. HEATING CAPACITY

## ■ MODEL : ASU18RL

AFR	412
-----	-----

			Indoor temperature							
			60°FDB		65°FDB		70°FDB		75°FDB	
Outdoor temperature	°FDB	°FWB	TC	PI	TC	PI	TC	PI	TC	PI
	5	-16	16.3	2.21	15.9	2.26	15.5	2.30	14.7	2.39
	14	-11	19.3	2.42	18.8	2.47	18.4	2.52	17.5	2.62
	23	-7	21.7	2.54	21.2	2.59	20.7	2.65	19.7	2.75
	32	-2	25.1	2.71	24.5	2.77	23.9	2.83	22.7	2.94
	41	3	28.5	2.90	27.9	2.96	27.2	3.02	25.8	3.14
	47	6	30.5	2.81	29.8	2.87	29.0	2.93	27.6	3.05
	50	8	31.6	2.82	30.9	2.87	30.1	2.93	28.6	3.05
	59	10	30.6	2.45	29.9	2.50	29.2	2.55	27.7	2.65

AFR : Air Flow Rate (CFM)  
TC : Total Capacity (kBTU)  
PI : Power Input (kW)

AFR	11.7
-----	------

			Indoor temperature							
			15.6°CDB		18.3°CDB		21.1°CDB		23.9°CDB	
Outdoor temperature	°CDB	°CWB	TC	PI	TC	PI	TC	PI	TC	PI
	-15.0	-16.0	4.76	2.21	4.65	2.26	4.54	2.30	4.31	2.39
	-10.0	-11.1	5.65	2.42	5.52	2.47	5.39	2.52	5.12	2.62
	-5.0	-7.2	6.37	2.54	6.22	2.59	6.06	2.65	5.76	2.75
	0.0	-2.2	7.36	2.71	7.18	2.77	7.01	2.83	6.66	2.94
	5.0	2.8	8.37	2.90	8.17	2.96	7.97	3.02	7.57	3.14
	8.3	6.1	8.95	2.81	8.73	2.87	8.52	2.93	8.09	3.05
	10.0	8.3	9.27	2.82	9.05	2.87	8.83	2.93	8.38	3.05
	15.0	10.0	8.97	2.45	8.76	2.50	8.54	2.55	8.12	2.65

AFR : Air Flow Rate (m<sup>3</sup>/min)  
TC : Total Capacity (kW)  
PI : Power Input (kW)

# 7. FAN PERFORMANCE

## 7-1. AIR VELOCITY DISTRIBUTION

### ■ MODEL : ASU18RL, ASU18CL

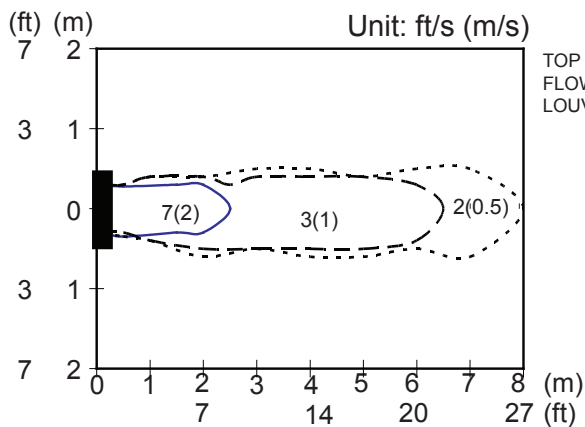

Note :  
Fan speed : High  
Operation mode :FAN  
Voltage : 230V

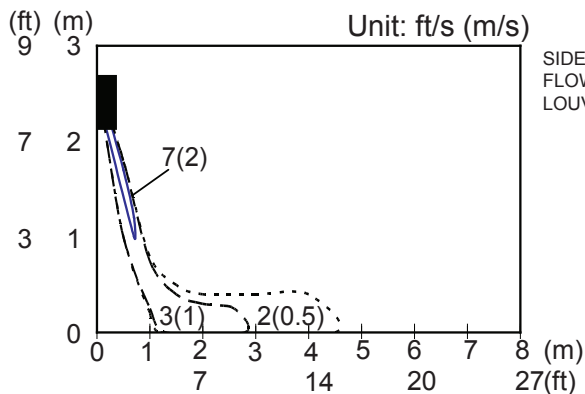
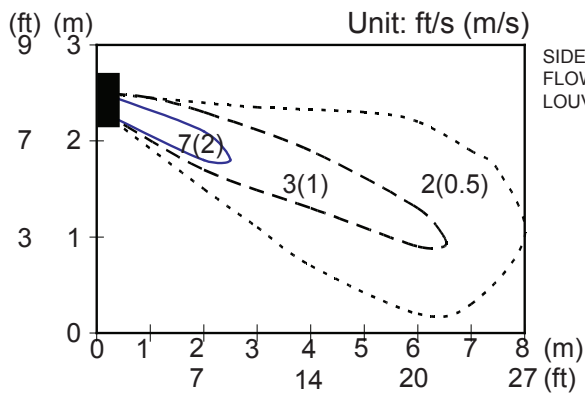
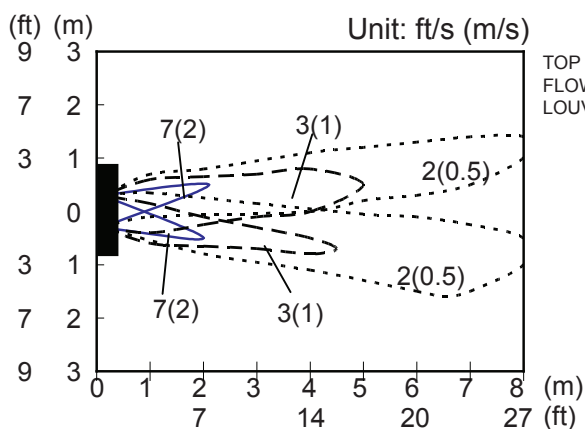

## 7-2. AIR FLOW

### ■ MODEL : ASU18RL

#### ● COOLING

Fan speed	Number of rotations (r.p.m)	Airflow	
HIGH	1480	700	m <sup>3</sup> /h
		194	l/s
		412	CFM
MED	1260	580	m <sup>3</sup> /h
		161	l/s
		341	CFM
LOW	1040	460	m <sup>3</sup> /h
		128	l/s
		271	CFM
QUIET	850	370	m <sup>3</sup> /h
		103	l/s
		218	CFM

#### ● HEATING

Fan speed	Number of rotations (r.p.m)	Airflow	
HIGH	1480	700	m <sup>3</sup> /h
		194	l/s
		412	CFM
MED	1300	600	m <sup>3</sup> /h
		167	l/s
		353	CFM
LOW	1110	500	m <sup>3</sup> /h
		139	l/s
		294	CFM
QUIET	950	420	m <sup>3</sup> /h
		117	l/s
		247	CFM

■ **MODEL : ASU18CL**

● **COOLING**

Fan speed	Number of rotations (r.p.m)	Airflow	
HIGH	1480	700	m <sup>3</sup> /h
		194	l/s
		412	CFM
MED	1260	580	m <sup>3</sup> /h
		161	l/s
		341	CFM
LOW	1040	460	m <sup>3</sup> /h
		128	l/s
		271	CFM
QUIET	850	370	m <sup>3</sup> /h
		103	l/s
		218	CFM

# 8. OPERATION NOISE

## 8-1. NOISE LEVEL CURVE

### MODEL : ASU18RL

#### ● COOLING

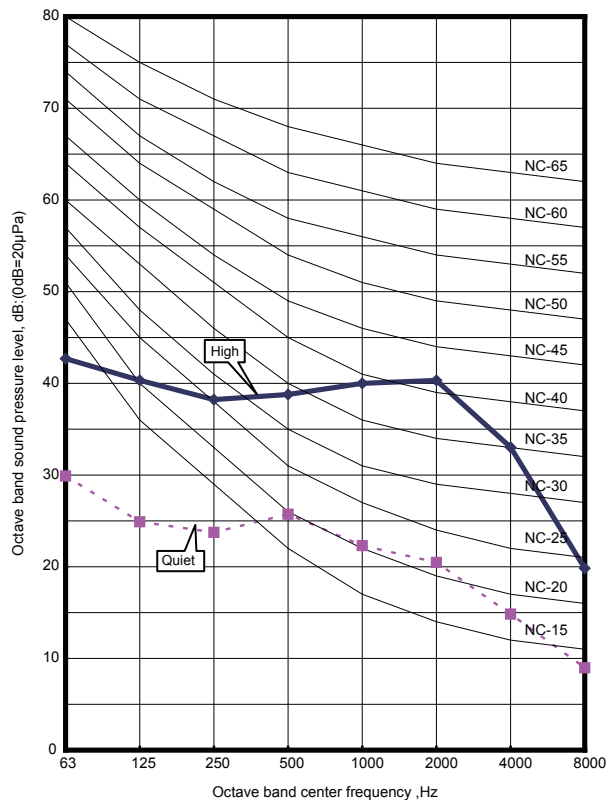

#### ● HEATING

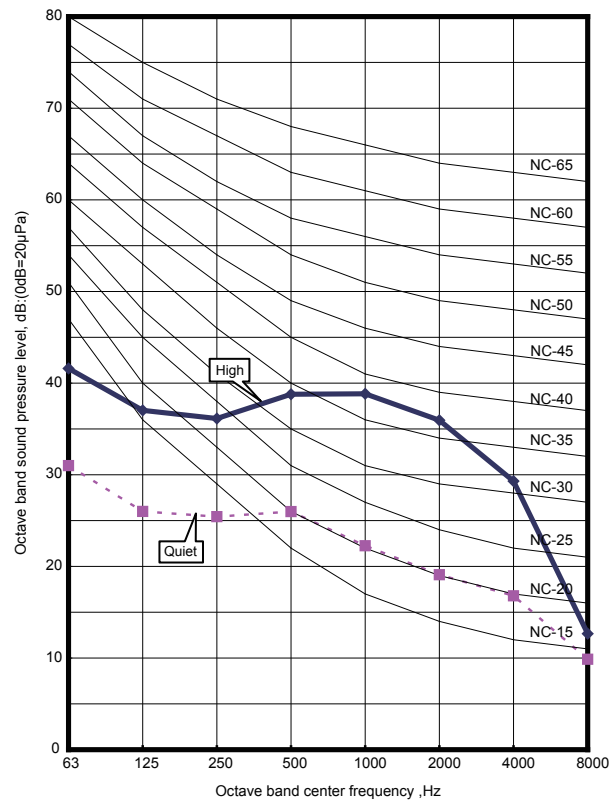

### MODEL : ASU18CL

#### ● COOLING

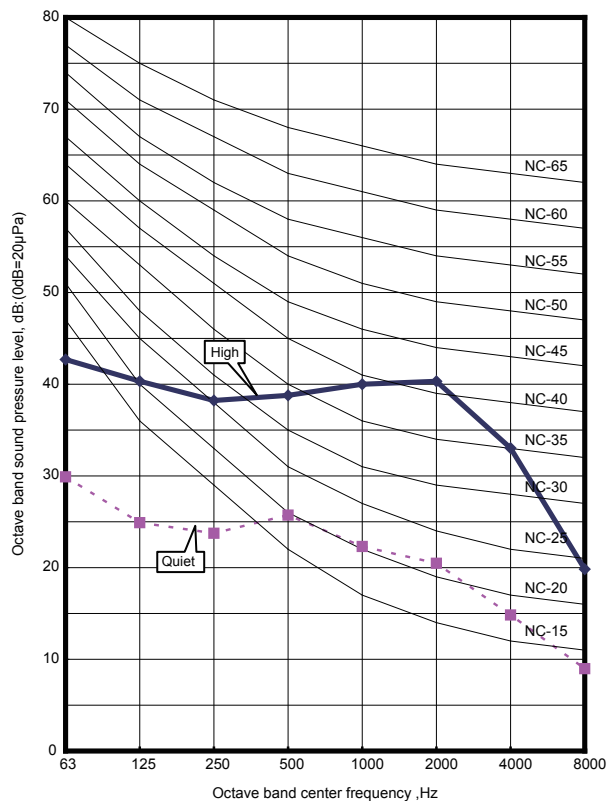

## 8-2. SOUND LEVEL CHECK POINT

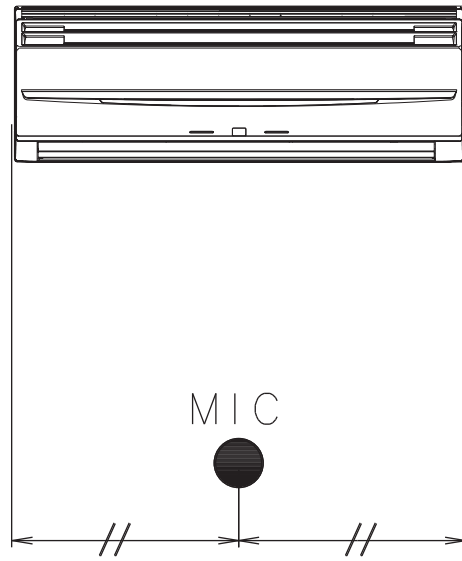
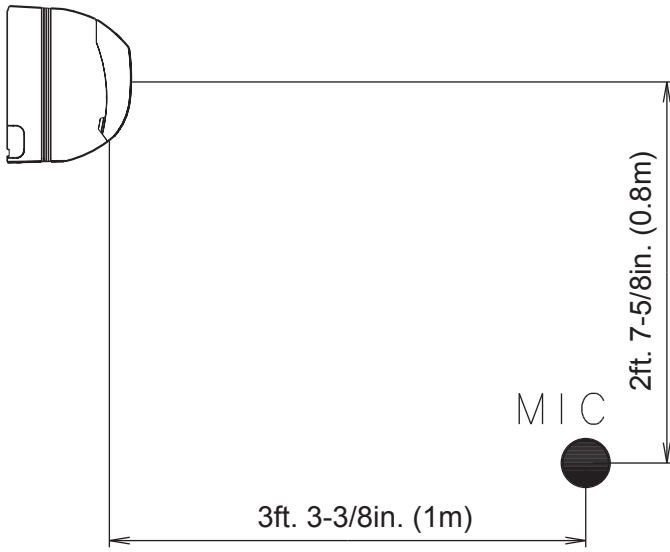



## 9. ELECTRIC CHARACTERISTICS

Model Name			ASU18RL	ASU18CL
Power Supply	Voltage	V	208/230~	
	Frequency	Hz	60	
Max Operating Current		A	0.3	0.3
*1)Wiring Spec.	Connection Cable	AWG	14	14
	Limited wiring length	ft.	70	70

\*1) Wiring Spec.



Selected Sample

(Selected based on Japan Electrotechnical Standard and Codes Committee E0005)

## 10. SAFETY DEVICES

	Protection form	Model	
		ASU18RL	ASU18CL
Circuit protection	Current fuse (PCB)	3.15A 250V	
Terminal protection	Current (Thermal) fuse	1A 250V (102°C) (213°F)	
Fan motor protection	Thermal protection program	$100^{+15}_{-10}$ °C OFF $95^{+15}_{-10}$ °C ON	$212^{+27}_{-18}$ °F OFF $203^{+27}_{-18}$ °F ON

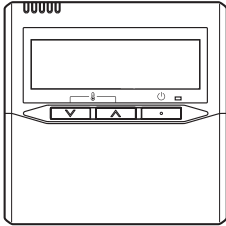
# 11. OPTIONAL PARTS

Exterior	Parts name	Model No.	Summary
	Wired remote controller	UTB-UUB	Unit control is performed by <b>wired remote controller</b>
	Apple-catechin filter	UTR-FA03-2	Fine dust, invisible mold spores, and harmful microorganisms are absorbed onto the filter by <b>static electricity</b> , and further growth is inhibited and deactivated by the polyphenol ingredient extracted from apples.
	Ion deodorisation filter	UTR-FA03-3	The filter deodorizes by powerfully decomposing absorbed odors using the oxidizing and reducing effects of ions generated by the ultra fine-particle ceramic.

# 11-1. WIRED REMOTE CONTROLLER

## FUNCTIONS

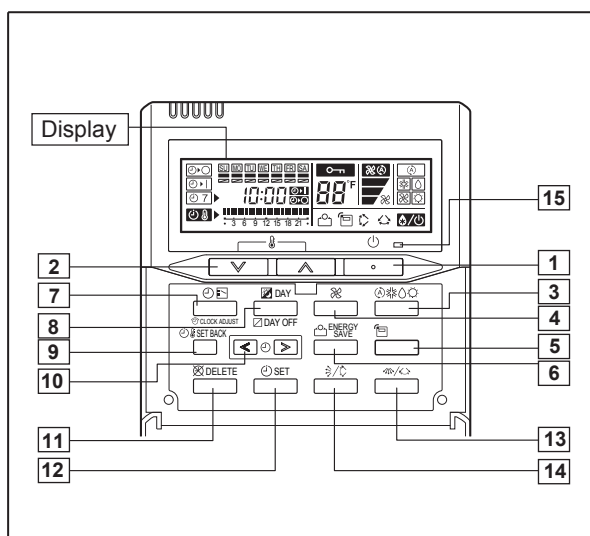

- 1 Start/Stop Button
- 2 Set Temperature Button
- 3 Master Control Button
- 4 Fan Control Button
- 5 THERMO SENSOR Button } \* 1)
- 6 ENERGY SAVE Button }
- 7 Timer Mode (CLOCK ADJUST) Button
- 8 DAY (DAY OFF) Button
- 9 SET BACK Button
- 10 Set Time Button
- 11 DELETE Button
- 12 SET Button
- 13 Horizontal airflow direction and swing Button \* 1)
- 14 Vertical airflow direction and swing Button
- 15 Operation Lamp

Display panel

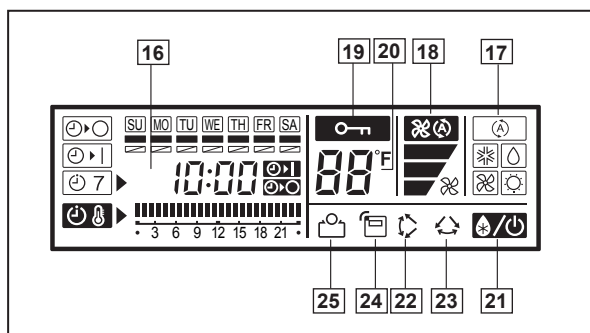

- 16 Timer and Clock Display
- 17 Operation Mode Display
- 18 Fan Speed Display
- 19 Operation Lock Display
- 20 Temperature Display
- 21 Defrost Display
- 22 Vertical Swing Display
- 23 Horizontal Swing Display
- 24 Thermo Sensor Display
- 25 Energy Save Display

\* 1) Button number 5, 6 and 13 cannot be operated.

## DIMENSION

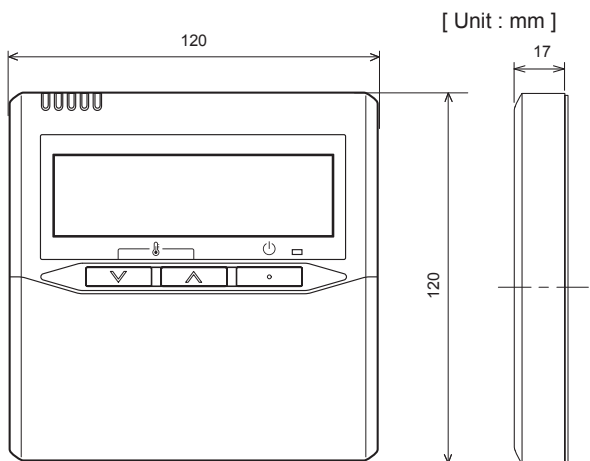

Front View

## SPECIFICATION

SIZE [H x W x D in. (mm)]	4-23/32 x 4-23/32 x 43/64 (120 x 120 x 17)
WEIGHT oz.( g )	5.6 (160)
CABLE LENGTH ft. ( m )	33 (10)
POWER ( V )	12

## **OUTDOOR UNIT**

### **2. SINGLE TYPE :**

**AOU18RL**

**AOU18CL**

# 1. SPECIFICATIONS

OUTDOOR UNIT  
AOU18RL, 18CL

OUTDOOR UNIT  
AOU18RL, 18CL

Type				INVERTER HEAT PUMP	INVERTER COOLING ONLY	
Model name				AOU18RL	AOU18CL	
Power source				208/230V~ 60Hz		
Available voltage range				187-253V~ 60Hz		
Starting current			A	8.6	7.7	
Fan	Airflow rate	Cooling	CFM	1177 (2000)	1177 (2000)	
		Heating	(m <sup>3</sup> /h)	1124 (1910)	—	
	Type × Q'ty			Propeller fan×1		
	Motor output		W	54		
Sound pressure level		Cooling	dB(A)	50	50	
		Heating		50	—	
Heat exchanger type		Dimensions (H × W × D)	in. (mm)	21-1/2 x 34-1/2 x 1-7/16 (546×876×36.4)		
		Fin pitch	FPI	20		
		Rows x Stages		2×26		
		Pipe type		Copper		
		Fin type		Aluminum		
Compressor		Type × Q'ty		Rotary ×1		
		Motor output	W	1,100		
Refrigerant		Type		R410A		
		Charge	lb.oz.(g)	2lb. 8-9/16oz.(1,150)		
Refrigerant oil		Type		POE(VG74)		
Enclosure		Material		Steel		
		Color		Beige		
Dimensions (H×W×D)		Net		mm	578×790×300	
				inch	22-3/4×31-1/8×11-13/16	
		Gross		mm	648×910×380	
				inch	27-5/8×38-3/4×16-1/8	
Weight		Net		lb.(kg)	88 (40)	
					Gross	
Connection pipe		Size	Liquid	in. (mm)	Φ1/4 (Φ6.35 )	
			Gas		Φ1/2 (Φ12.7)	
		Method			Flare	
		Max. length		ft. (m)	66(20) [chargeless:49(15)]	
		Max. height difference			49(15)	
Operation range		Cooling	°F (°C)	14 to115 (-10 to 46)		
		Heating		5 to 75 (-15 to 24)		

**Note :**

Specifications are based on the following conditions.

Cooling : Indoor temperature of 80°F (26.67°C)DB/67°F (19.44°C)WB, and outdoor temperature of 95°F (35°C)DB/75°F (23.9°C)WB.

Heating : Indoor temperature of 70°F (21.11°C)DB/59°F (15°C)WB, and outdoor temperature of 47°F (8.33°C)DB/43°F (6.11°C)WB.

Pipe length : 24ft.7in.(7.5 m), Height difference : 0 m.(Outdoor unit - Indoor unit)

## 2. DIMENSIONS

### ■ MODEL : AOU18RL, AOU18CL

Unit : in. (mm)

OUTDOOR UNIT  
AOU18RL, 18CL

OUTDOOR UNIT  
AOU18RL, 18CL

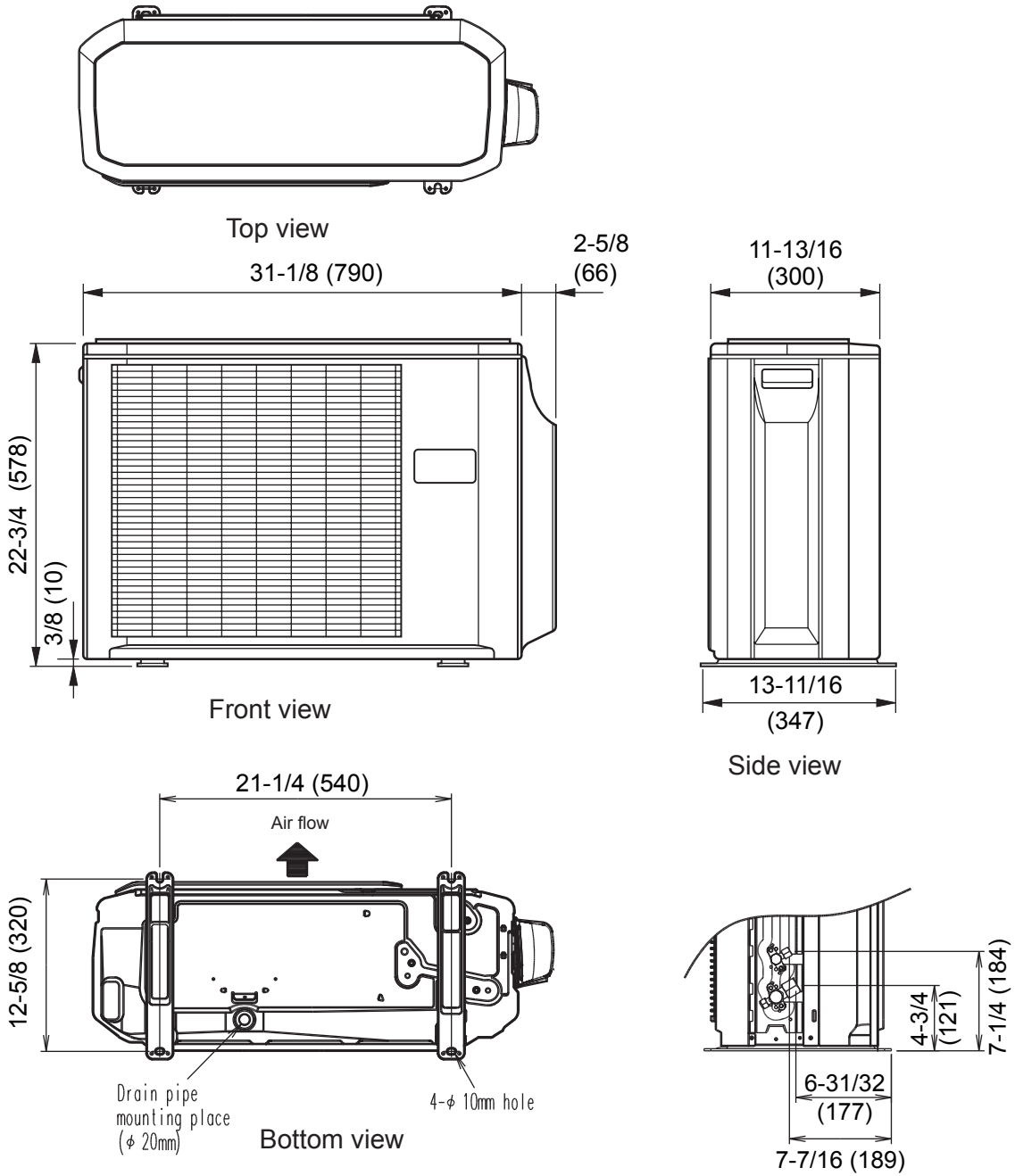

### ■ INSTALLATION PLACE

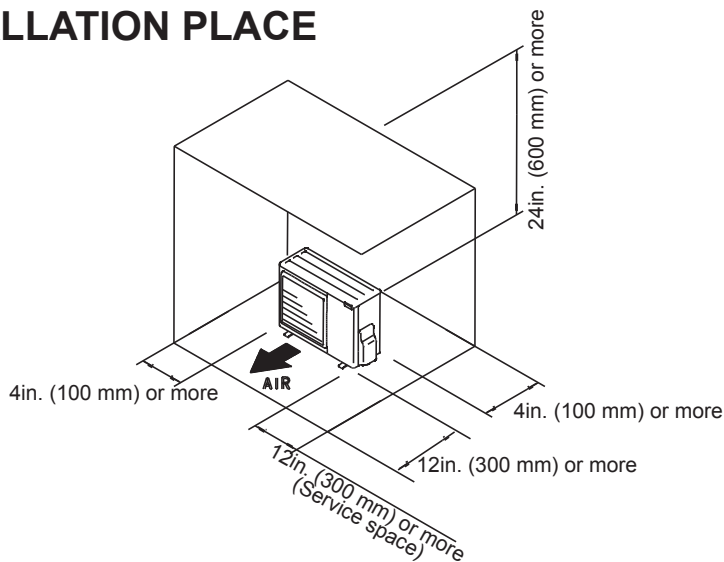

If the space is larger than that is stated, the condition will be the same as that are no obstacles.

### 3. REFRIGERANT CIRCUIT

■ MODEL : AOU18RL

OUTDOOR UNIT  
AOU18RL, 18CL

OUTDOOR UNIT  
AOU18RL, 18CL

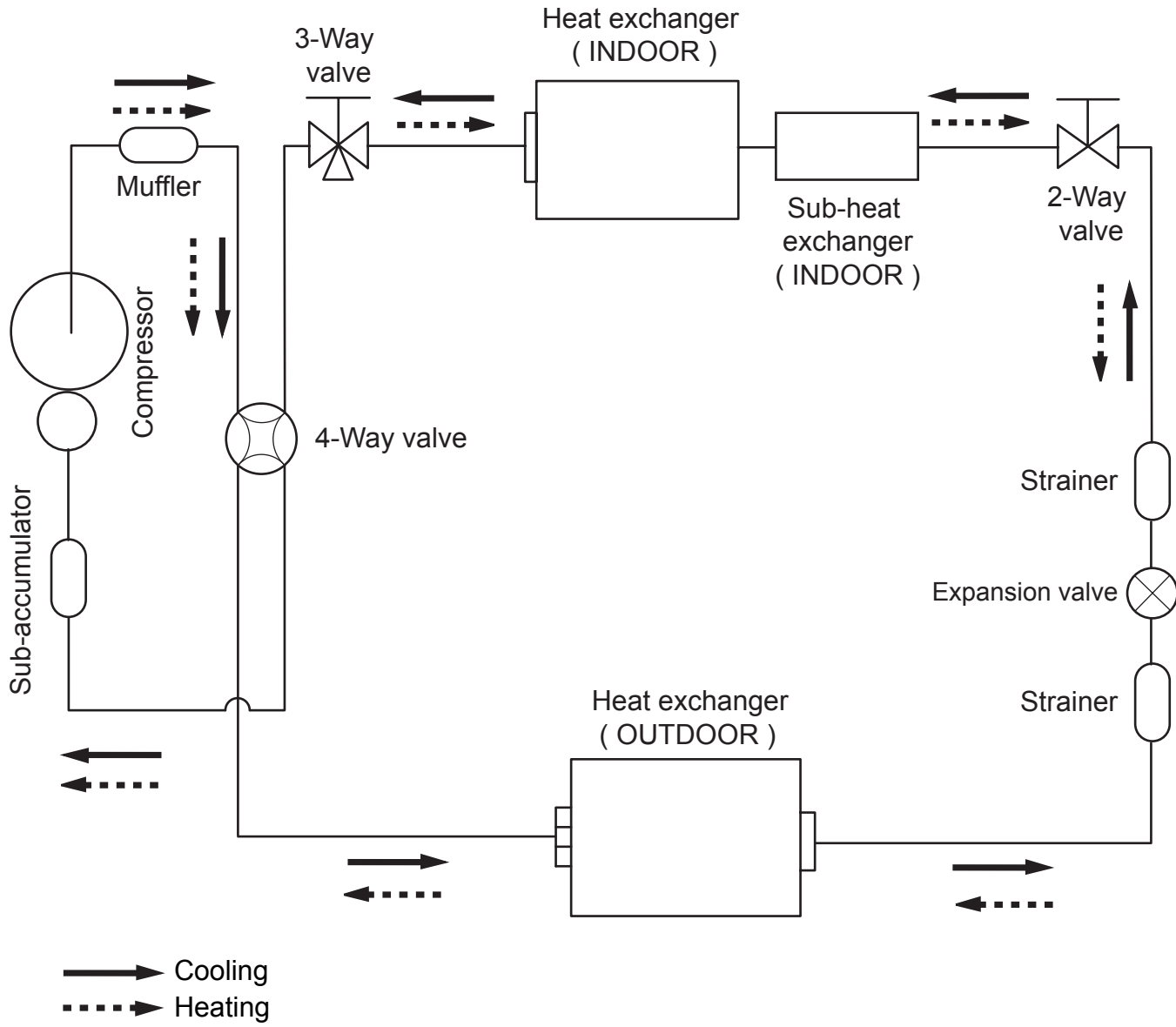

Refrigerant pipe diameter  
 Liquid : 1/4" (6.35 mm)  
 Gas : 1/2" (12.7 mm)



■ MODEL : AOU18CL

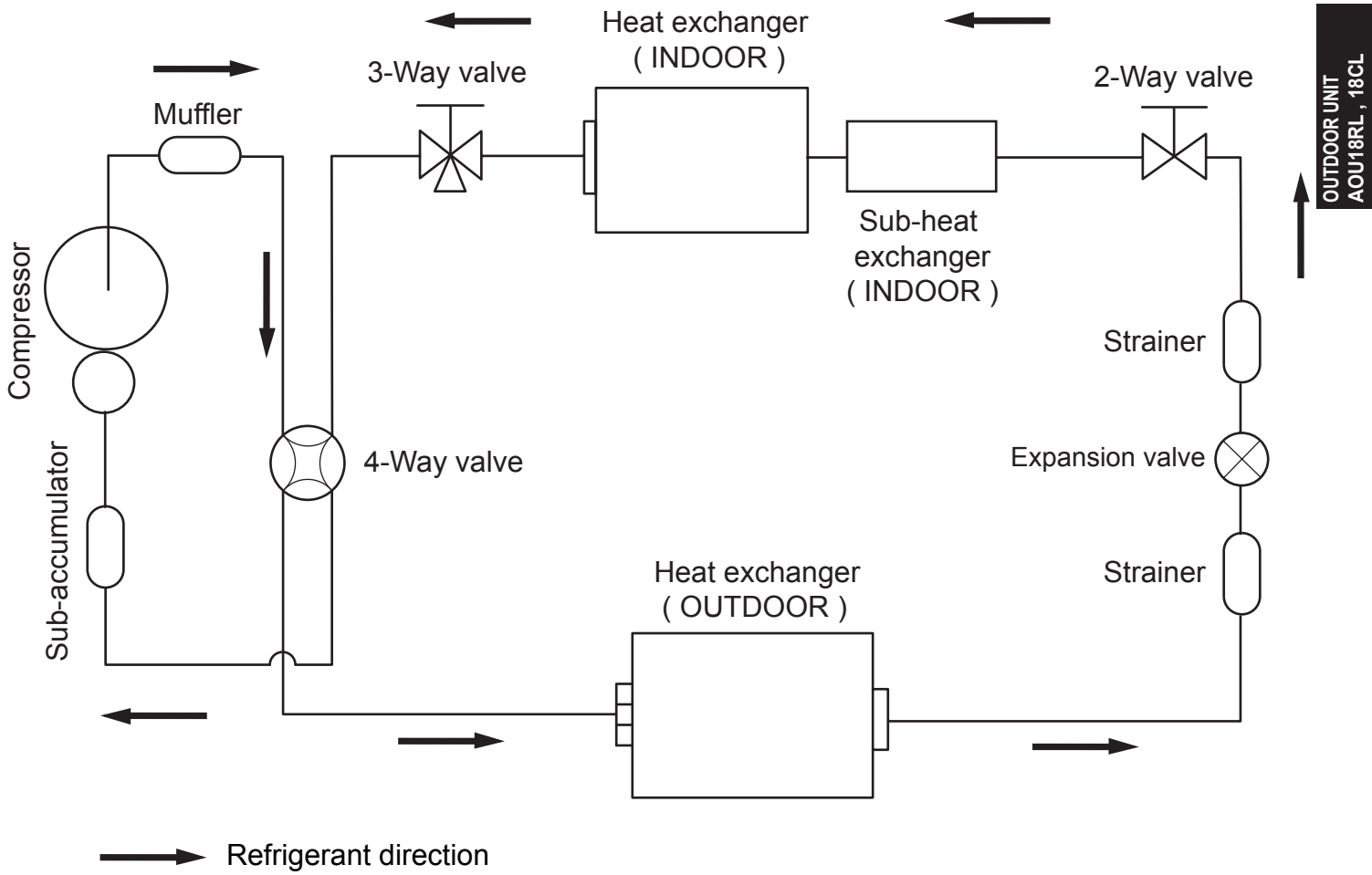

Refrigerant pipe diameter  
 Liquid : 1/4" (6.35 mm)  
 Gas : 1/2" (12.7 mm)

# 4. WIRING DIAGRAMS

■ MODEL : AOU18RL, AOU18CL

OUTDOOR UNIT  
AOU18RL, 18CL

OUTDOOR UNIT  
AOU18RL, 18CL

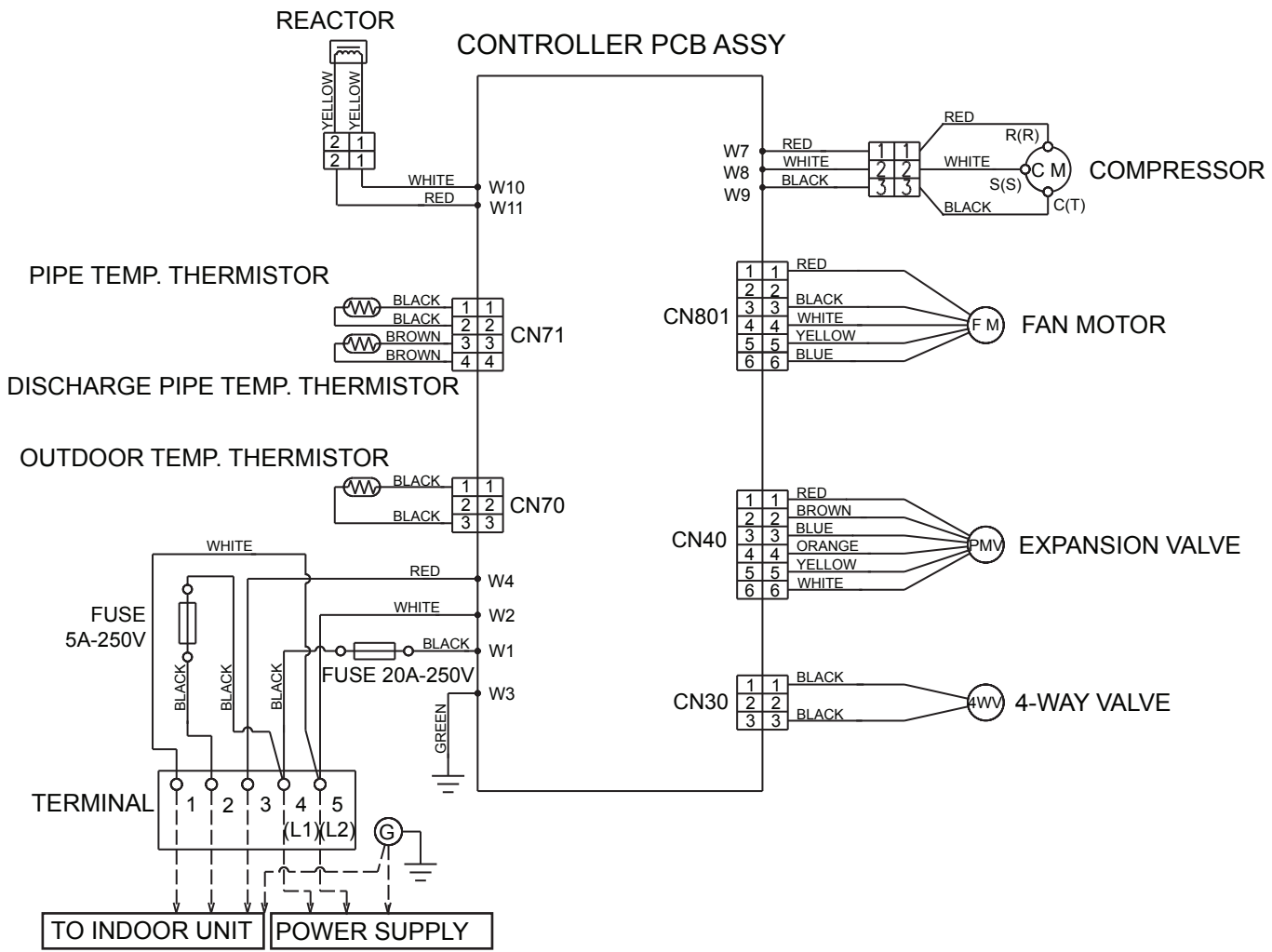

# 5. COEFFICIENT OF COMPENSATION FOR PIPE LENGTH AND HEIGHT DIFFERENCE

## MODEL : AOU18RL, AOU18CL

OUTDOOR UNIT  
AOU18RL, 18CL

OUTDOOR UNIT  
AOU18RL, 18CL

COOLING				Pipe length				
				5m	7.5m	10m	15m	20m
				17ft.	25ft.	33ft.	49ft.	66ft.
Height difference H	* 1 Indoor unit is upper than outdoor unit.	15m	49ft.	-	-	-	0.953	0.950
		10m	33ft.	-	-	0.983	0.968	0.966
		7.5m	25ft.	-	0.988	0.987	0.972	0.970
		5m	17ft.	0.992	0.992	0.991	0.976	0.974
	* 2 Indoor unit is under than outdoor unit	0m	0ft.	1.000	1.000	0.999	0.984	0.982
		-5m	-17ft.	1.000	1.000	0.999	0.984	0.982
		-7.5m	-25ft.	-	1.000	0.999	0.984	0.982
		-10m	-33ft.	-	-	0.999	0.984	0.982
		-15m	-49ft.	-	-	-	0.984	0.982

HEATING				Pipe length				
				5m	7.5m	10m	15m	20m
				17ft.	25ft.	33ft.	49ft.	66ft.
Height difference H	* 1 Indoor unit is upper than outdoor unit.	15m	49ft.	-	-	-	0.920	0.894
		10m	33ft.	-	-	0.982	0.920	0.894
		7.5m	25ft.	-	1.000	0.982	0.920	0.894
		5m	17ft.	0.993	1.000	0.982	0.920	0.894
	* 2 Indoor unit is under than outdoor unit	0m	0ft.	0.993	1.000	0.982	0.920	0.894
		-5m	-17ft.	0.988	0.995	0.977	0.916	0.889
		-7.5m	-25ft.	-	0.993	0.975	0.913	0.887
		-10m	-33ft.	-	-	0.972	0.911	0.885
		-15m	-49ft.	-	-	-	0.902	0.876

Height difference H

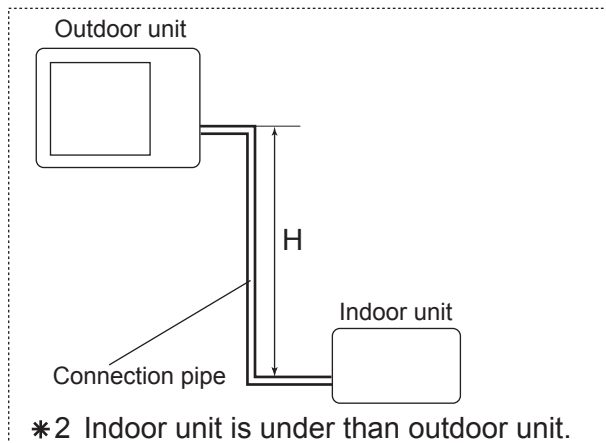
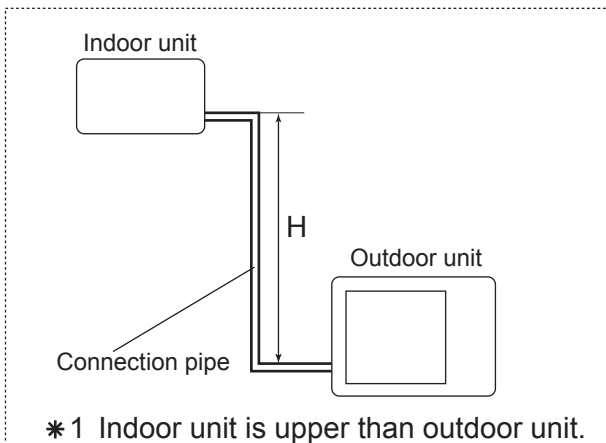

## 6. ADDITIONAL CHARGE CALCULATION

### ■ MODEL : AOU18RL, AOU18CL

Refrigerant type		R410A
Refrigerant amount	lb.oz.	2lb. 8.6oz
	g	1150

### ● REFRIGERANT CHARGE

Pipe length	ft.	~49	66	0.21oz./ft. (20g/m)
	m	~15	20	
Additional charge	oz.	0 (Chargeless)	+3.53	
	g	0 (Chargeless)	+100	

## 7. AIR FLOW

### ■ MODEL : AOU18RL

#### ● COOLING

Number of rotations (r.p.m)	Airflow	
	860	2000
556		l/s
1177		CFM

#### ● HEATING

Number of rotations (r.p.m)	Airflow	
	820	1910
531		l/s
1124		CFM

### ■ MODEL : AOU18CL

#### ● COOLING

Number of rotations (r.p.m)	Airflow	
	860	2000
556		l/s
1177		CFM

# 8. OPERATION NOISE

## 8-1. NOISE LEVEL CURVE

### MODEL : AOU18RL

#### COOLING

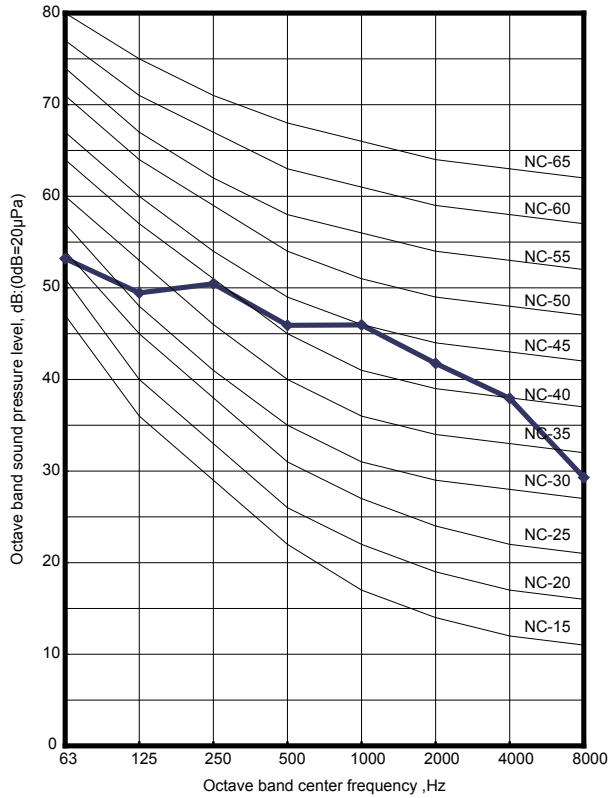

#### HEATING

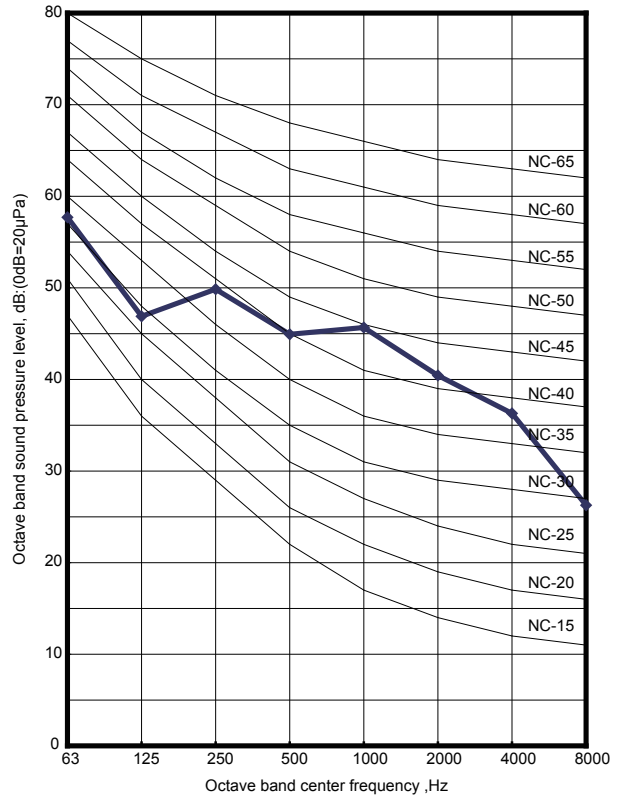

### MODEL : AOU18CL

#### COOLING

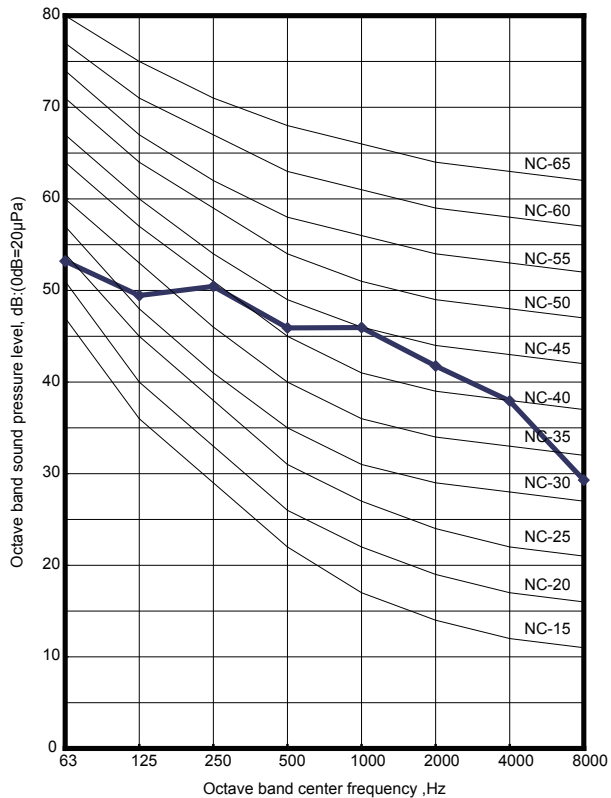

OUTDOOR UNIT  
AOU18RL, 18CL

OUTDOOR UNIT  
AOU18RL, 18CL

# 8-2. SOUND LEVEL CHECK POINT

OUTDOOR UNIT  
AOU18RL, 18CL

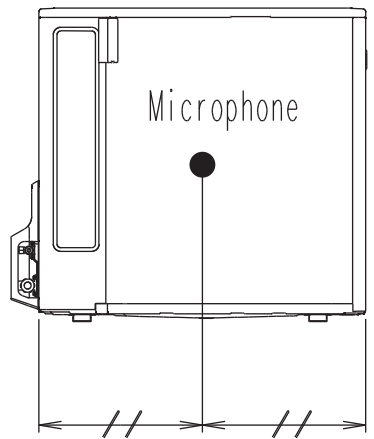
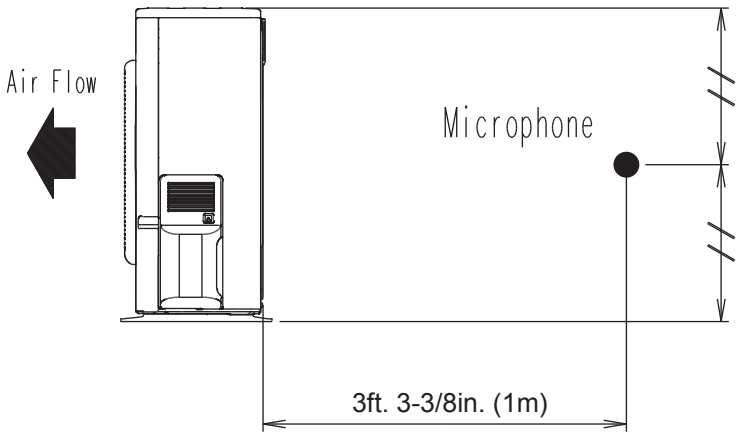

OUTDOOR UNIT  
AOU18RL, 18CL

## 9. ELECTRIC CHARACTERISTICS

Model Name			AOU18RL	AOU18CL
Power Supply	Voltage	V	208/230~	
	Frequency	Hz	60	
Max Operating Current		A	13.5	9.0
Starting Current		A	8.6	7.7
*1) Wiring Spec.	Main Fuse (Circuit breaker) Current	A	20	20
	Power Cable	AWG	14	14
	*2)Limited wiring length	ft.	47	70

\*1) Wiring Spec.

Selected Sample

(Selected based on Japan Electrotechnical Standard and Codes Committee E0005)

\*2) Limited Wiring length :

This is the wiring length in case voltage descent is less than 2%.

When the wiring length becomes long, please select the wiring of a more larger diameter.



# 10. SAFETY DEVICES

OUTDOOR UNIT  
AOU18RL, 18CL

OUTDOOR UNIT  
AOU18RL, 18CL

	Protection form	Model	
		AOU18RL	AOU18CL
Circuit protection	Current fuse (NEAR THE TERMINAL)	20A 250V	
		5A 250V	
	Current fuse (MAIN PRINTED CIRCUIT BOARD)	15A 250V	
		3.15A 250V	
Fan motor protection	Thermal protection program	OFF: 212 <sup>+27</sup> <sub>-18</sub> °F ON: 203 <sup>+27</sup> <sub>-18</sub> °F	OFF: 100 <sup>+15</sup> <sub>-10</sub> °C ON: 95 <sup>+15</sup> <sub>-10</sub> °C
Compressor protection	Thermal protection program (DISCHARGE TEMP.)	OFF: 230 °F ON: After 7 minutes	OFF: 110 °C ON: After 7 minutes