

Submission Data: 12RFLW1 Inverter Driven Heat Pump

12,000 BTU Wall Mount

Job Name: _____

Date: _____

Location: _____

Approval: _____

Engineer: _____

Construction: _____

Submitted to: _____

Unit #: _____

Submitted by: _____

Drawing #: _____

Reference: _____

General Features

- Wired or wireless remote
- Apple catchin filter
- Ion deodorizing filter
- Auto louver: up/down
- Auto louver: 4-way
- Low ambient cooling
- Cold prevention
- Sleep timer
- 24-hour timer
- Dry mode
- Standard Warranty: 5 years parts, 7 years compressor. Applies to systems purchased before June 1st 2015*
- Extended Warranty: 10 years parts, 10 years compressor. Systems that have been installed on or after June 1st 2015 by licensed contractors and the online Product Registration has been submitted.**
- Elite Contractor Extended Warranty: 12 years parts, 12 years compressor. Systems that have been installed on or after June 1st 2015 by contractors who have met requirements and have been approved for elite contractor status plus, the online Product Registration has been submitted.***

Model Information

Condenser..... AOU12RFLW1

Evaporator..... ASU12RLF1

Electrical..... 208/230 V AC 1ph-60HZ

Available Voltage Range..... 187 - 253 V +/- 10%

Max Fuse Size..... 20 A

Max Operating Current

Evaporator..... 0.4 A

Condenser..... 5.9 A

Input Power

Cooling..... 0.96 kW

Heating..... 1.28 kW

Running Current

Cooling..... 4.4 A

Heating..... 5.9 A

Capacity

Nominal Cooling..... 12,000 Btu/h

Min-Max Cooling..... 3,100 – 13,300 Btu/h

Nominal Heating..... 16,000 Btu/h

Min-Max Heating..... 3,100 – 19,100 Btu/h

Compressor..... Rotary x1

Motor Output..... 750 W

Refrigerant..... R410a

Charge..... 2 lbs. 5 oz.

Oil..... VG74

Fan Motor

Type: DC (condenser)..... Propeller x1

Type: DC (evaporator)..... Cross flow fan x1

Motor Output (condenser)..... 37 W

Motor Output (evaporator)..... 30 W

Heat Exchanger

Condenser

(H x W x D) in. (mm)..... 19-13/16 x 35-1/4 x 1-7/16 (504x896x36.4)

Fin Pitch..... 18 FPI

Rows x Stages..... 2 x 24

Pipe Type (Material)..... Grooved H-Pin (Copper)

Type (Material)..... Corrugate (Aluminum)

Note: Specifications are based on the following conditions:
Cooling: Indoor temperature of 80°F (26.7°C) DB/67°F (19.44°C) WB, and outdoor temperature of 95°F (35°C) DB/75°F (23.9°C) WB.
Heating: Indoor temperature of 70°F (21.11°C) DB/59°F (15°C) WB, and outdoor temperature of 47°F (8.33°C) DB/43°F (6.11°C) WB.
Pipe length: 24ft. 7in. (7.5m), Height difference: 0ft. (0m) (Outdoor unit – indoor unit)
(*Standard warranty / **10 year warranty / ***12 year warranty)



Operation Temperature Range

Cooling..... 15°F to 115°F (-10°C - 46°C)

Heating..... 5°F to 75°F (-15°C - 24°C)

Efficiency

SEER..... 22.0

EER (cooling)..... 3.66 kW/kW

COP (heating)..... 3.66 kW/kW

HSPF (heating)..... 11.0 Btu/hW

Enclosure

Material

Evaporator..... Polystyrene

Condenser..... Painted galvanized steel

Color

Condenser..... Beige (10 YR 7.5/1.0 NN)

Evaporator..... White

Sound Pressure Level

Condenser (max)..... 49 dB(A)

Evaporator (max)..... 43 dB(A)

Dimensions

H x W x D

Condenser in. (mm)..... 21-1/4 x 31-1/8 x 11-7/16 (540x790x290)

Evaporator in. (mm)..... 10-9/16 x 33-1/16 x 8 (268x840x203)

Connection Pipe

Liquid..... Ø1/4 in. (Ø6.35 mm)

Gas..... Ø3/8 in. (Ø9.52 mm)

Method (Liquid/Gas)..... Flare

Max Length {(Pre-charge)}..... 66 ft. (20 m) {(49 ft.) (15 m)}

Max Height Difference..... 49 ft. (15 m)

Weight

Condenser..... 80 lbs. (36 kg)

Evaporator..... 19 lbs. (8.5 kg)

Accessories

UTY-RNNUM[^]1..... Wired remote control

UTY-RVNUM[^]..... Wired remote control (backlit, shows room temp.)

UTY-RSNUM[^]1..... Wired remote control (simple)

UTY-XWZZ5..... Dry contact wire kit

Intertek®ETL Number

AOU12RFLW1..... 91986

ASU12RLF1..... 91986

[^]1 Requires interface kit # UTY-XCBXZ2 in order to connect these devices to them.



Dimensions: 12RLFW1

[Unit: in. (mm)]

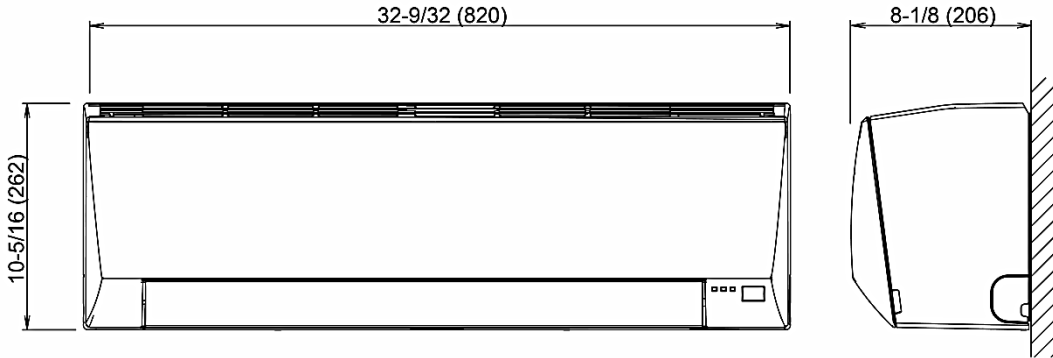

Top view

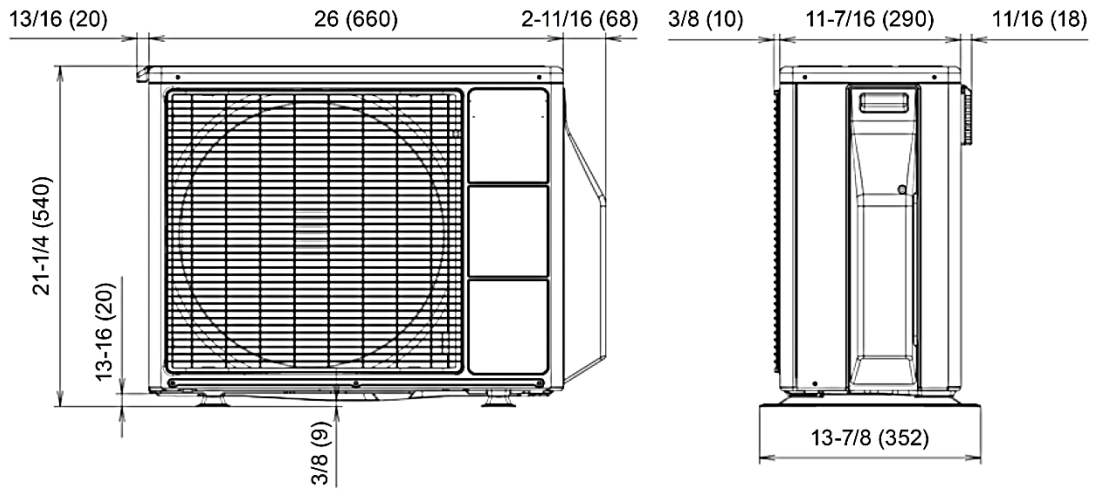

Front view

Side view

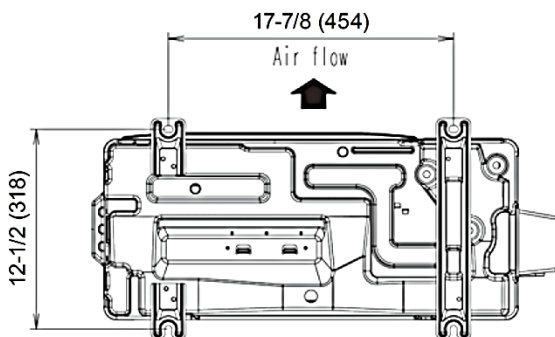

Bottom view

