

CL FAN COIL UNITS

INSTALLATION, OPERATION & MAINTENANCE INSTRUCTIONS

****WARNING TO INSTALLER, SERVICE PERSONNEL AND OWNER****

Altering the product or replacing parts with non authorized factory parts voids all warranty or implied warranty and may result in adverse operational performance and/or a possible hazardous safety condition to service personnel and occupants. Company employees and/or contractors are not authorized to waive this warning. Current **Maintenance Program** is available at www.firstco.com under "Product Information".

GENERAL

The manufacturer assumes no responsibility for equipment installed in violation of any code requirement.

These instructions give information relative to the installation of these fan coil units only. For other related equipment refer to the proper instructions.

Material in this shipment has been inspected at the factory and released to the transportation agency in good condition. When received, a visual inspection of all cartons should be made immediately. Any evidence of rough handling or apparent damage should be noted on the delivery receipt and the material inspected in the presence of the carrier's representative. If damage is found, a claim should be filed against the carrier immediately.

FAN COIL UNIT

The installer must adhere strictly to all local and national code requirements pertaining to the installation of this equipment. These units are designed to be installed in a vertical, upflow position either hung on a wall or set on a platform within an equipment closet.

******* WARNING *******

Extreme caution must be taken that no internal damage will result if screws or holes are drilled into the cabinet.

All fan coil units are U.L. Listed for installation with zero inches clearance to combustible materials. This includes the fan coil cabinet, discharge plenum and connecting ducts.

Sufficient clearance must be provided at the front of the fan coil to allow access to the air filter, electrical controls and removal of the motor/blower assembly for servicing. This clearance distance should be approximately the same as the depth of the fan coil unit.

The unit should be leveled in such a way that there is slope toward the condensate drain nipple to assure positive drainage.

NOTE: It is important at this point to consider noise and vibration. If this installation is in a noise sensitive area then placement of resilient isolators or other means of sound deadening may be necessary.

These fan coil units are designed for quiet operation, however, all air conditioning equipment will transfer some amount of noise to the conditioned space. This should be taken into consideration when planning the location of the equipment as well.

AIR DISTRIBUTION DUCTS

All duct work must be installed in accordance with National Fire Protection Association Codes 90A and 90B. Ducts should be adequately insulated to prevent condensation during the cooling cycle and to minimize heat loss during the heating cycle. Provision for connecting the return air duct is located on the side of the unit. The installer must cut out the center section and bend the 3/4" flanges out. The backing insulation must also be removed. See illustration p.3. Duct sizing for unique arrangements or long duct runs must be confirmed by a local professional. The manufacturer will not be responsible for misapplied equipment.

******* WARNING *******

Unit must not be operated during building construction due to excessive airborne dust and debris. The unit must not be operated under any circumstances without an air filter in place.

ELECTRICAL

All wiring must comply with local and national code requirements. Units are provided with wiring diagrams and nameplate data to provide information required for necessary field wiring. Knockouts are provided on the cabinet for connection of power supply.

These units are provided with a Class 2 transformer for 24-volt control circuits. Should any add-on equipment also have a Class 2 transformer furnished, care must be taken to prevent interconnecting outputs of the two transformers by using a thermostat with isolating contacts.

INSTALLATION PRECAUTIONS

Installation of this fan coil should only be performed by a licensed contractor to ensure proper installation and the safety of the installer. The following are some precautions to be followed for typical installations.

- Always use proper tools and equipment.
- No wiring or other work should be attempted without first ensuring that the fan coil is completely disconnected from the power source and locked out. Always verify that a good ground connection exists prior to energizing any power sources.
- Always review the nameplate on

each unit for proper voltage and control configurations. This information is determined from the components and wiring of the unit and may vary from unit to unit.

- When soldering or brazing to the unit, it is recommended to have a fire extinguisher readily available. When soldering close to metering devices or other components, heat shields or wet rags are required to prevent damage.
- When the fan coil unit is in operation components are rotating at high speeds.
- Units must be installed level to ensure proper drainage and operation.
- Check unit prior to operation to ensure that the condensate water will drain toward the drain connection. An overflow drain or an overflow switch installed in the fan coil may be required as a back up to a clogged primary drain.
- Be sure that the drain pan is free from foreign material prior to start up.
- Check filter media installation to ensure that it is installed correctly. Use the directional arrows or other information on the filter to determine the proper flow direction.
- Ensure that the air distribution system does not exceed the external static rating of the unit.

******* WARNING *******

Any devices such as fan switches or thermostats that have been furnished by the factory for field installation must be wired in strict accordance with the wiring diagram that is supplied with the unit. Failure to do so could result in damage to components and will void all warranties.

******* WARNING *******

R-410a can become combustible if mixed with air at elevated temperatures and/or pressures. Property damage, personal injury or death could result if this warning is ignored.

MOUNTING

It is important to ensure that the fan coil is securely mounted and the structure is sufficient to support the weight of the equipment. All anchors for mounting the equipment must be placed and sized to ensure a safe and durable installation.

COOLING COIL PIPING

This fan coil unit is supplied with a direct expansion refrigerant coil. The suction and liquid refrigerant lines must be sized in accordance with the outdoor unit manufacturer's recommendations.

Condensate drain lines must be installed with adequate slope away from the unit to assure positive drainage. Since the drain pan is located on the suction side of the blower, a negative pressure exists at the drain pan and a minimum trap of 1-1/2 inches must be provided in the drain line to assure proper drainage.

CAUTION: It is highly recommended that a condensate overflow switch be installed to prevent damage which may result from an overflow of the condensate pan.

NOTE: *If a Condensate Overflow Shut-off Switch, that is designed to be installed in the drain line, is used in place of a secondary drain line, then the cut-off switch should be located in the primary drain line between the fan coil unit and the P-trap.*

OPERATION AND MAINTENANCE

******* WARNING *******

When connecting piping to fan coil units, do not bend or reposition the coil header tubing for alignment purposes. This could cause a tubing fracture resulting in a refrigerant leak when pressure is applied to the system.

Pre-start Check

- Check that supply voltage matches nameplate data.
- Ensure that the unit is properly grounded.
- With power off, check blower wheel

set screws for tightness and ensure that the blower wheels rotates freely and quietly.

- Check that the refrigerant coil connections and piping have been leak checked and insulated as required.

******* WARNING *******

Do not touch any rotating component with any object. Damage to the equipment and personal injury can occur.

Start-up and Maintenance

Before start-up, all of the components should be given a thorough check. Optimal operation of this equipment requires cleanliness. Often after installation of this equipment additional construction activities occur. Care must be taken to protect the equipment from debris during these construction phases. All access panels and filters must be in place before operation of the units.

Fan

The fan should be inspected and cleaned, in conjunction with maintenance of the motor and bearings. It is important to keep the wheels clean in order to avoid imbalance and vibration.

Motor

Check motor connections to ensure that they are secure and made in accordance with the wiring diagram. The blower motor should be cleaned annually.

Filter

The air filter should be cleaned or replaced every 30 days or more frequently if severe conditions exist. Always replace the filter with the same type as originally furnished.

Coil

Any dust or other contaminants which accumulate on the heat transfer surfaces interferes with the air flow and impairs heat transfer. The coil must be kept clean by any of the following methods.

- Cleaning with low pressure compressed air.
- Flushing or rinsing with water (a detergent is advisable for greasy surfaces).

Drain Piping

- The drain should always be:
- Connected or piped to an acceptable disposal point sloped away from the unit at least 1/8" per foot
 - Checked before summer operation
 - Periodically checked during summer operation

Preventative Maintenance

To achieve maximum performance and service life of each piece of equipment a formal schedule of regular maintenance should be established and maintained.

******* WARNING *******

- Always wear eye protection.
- When fan coil is operating, some components are operating at high speeds. Personal injury can result from touching these items with any object
- All electrical and service access panels must be returned and secured in their proper place.
- Clear surrounding area of all tools, equipment and debris.
- Check the entire unit to ensure it's cleanliness.

******* WARNING *******

The manufacturer does NOT WARRANT equipment subjected to abuse. Metal chips, dust, drywall tape, paint over spray, etc. can void warranties and liability for equipment failure, personal injury and property damage.

******* WARNING *******

R-410a systems operate at much higher pressures than systems using former refrigerants. Use only equipment certified for use with R-410a.

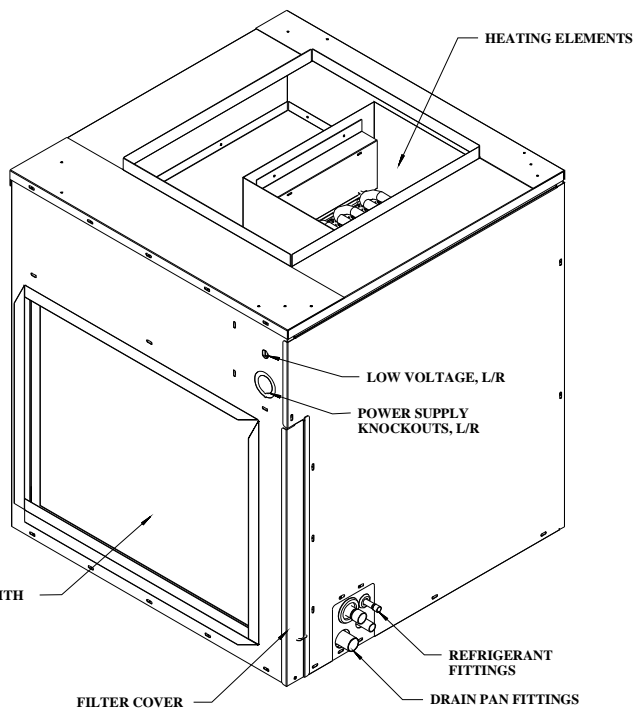
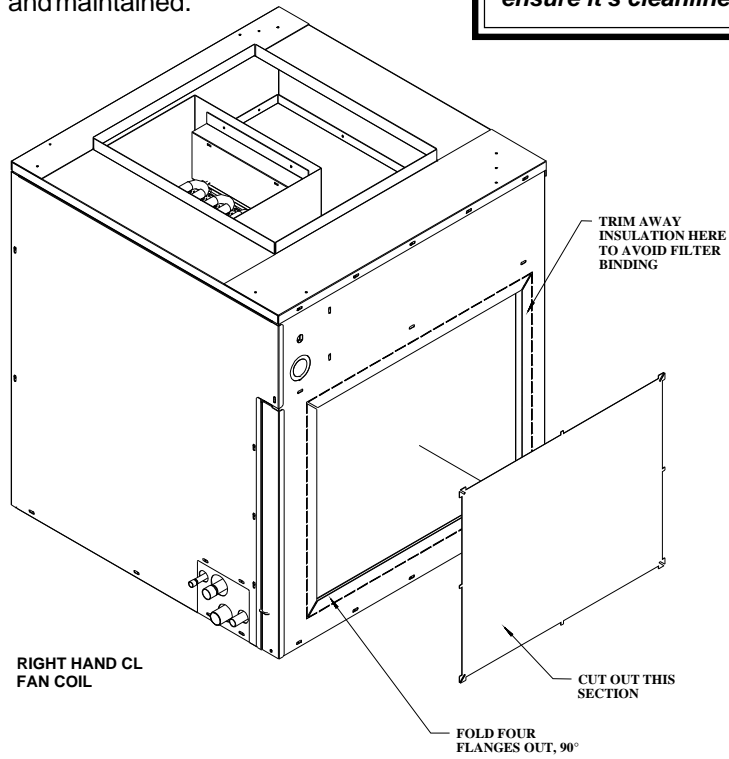

****MAINTENANCE UPDATES****
 For a current copy of the Maintenance Program log on to www.firstco.com and look under "Product Information"

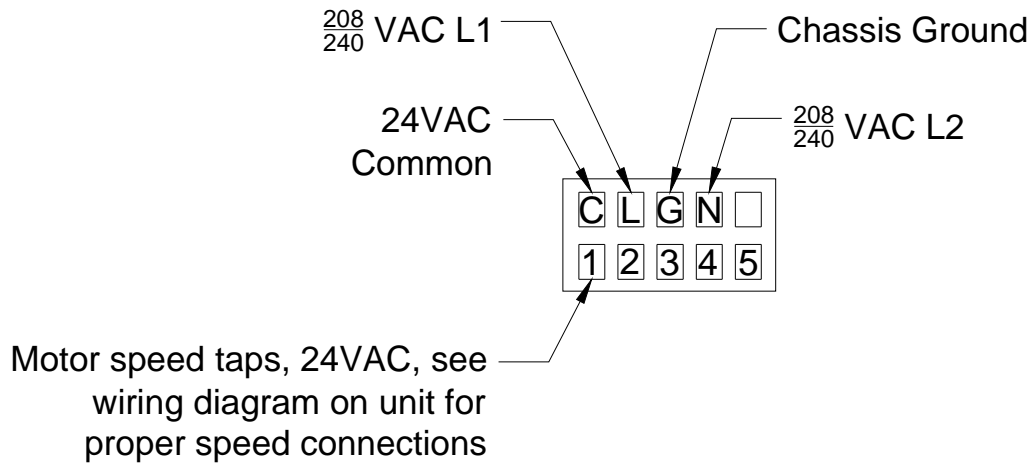

BRUSHLESS DC MOTOR CONNECTIONS
IF SO EQUIPPED
SEE WIRING DIAGRAM

Figure 1

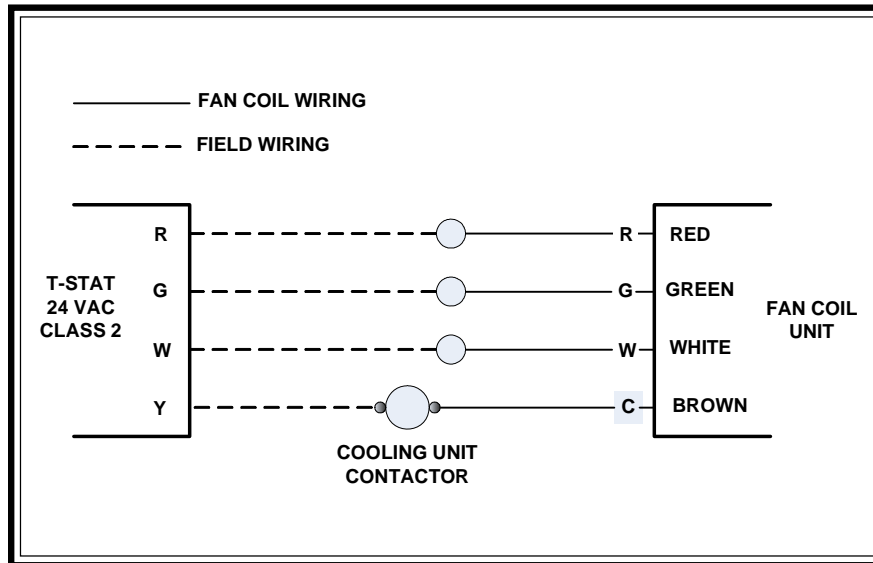

Figure 2 Low Voltage Wiring