

TECHNICAL BULLETIN

Model UZC4 Zone Control

Leave this bulletin on the job site for future reference!

The UZC4 Universal Zone Control System allows you to easily upgrade an inefficient single zone HVAC system, into an Automated, Multi-zone, Energy saving, Comfort producing, Safety Minded, HVAC system. With Superior design, Intuitive firmware, Building Code Compliant support, Simple setup options, and Easy to understand wiring, the UZC4 Zoning system is the Designer/Contractors dream. Combined with Patented EWC motorized dampers and practically any Off-the-shelf Conventional or Heat Pump style Thermostats, EWC has set a New Industry Standard in Large Residential and Commercial HVAC Air Zoning Systems.

Zone Capacity

The main module controls four air zones using 24 vac motorized air dampers and may be expanded up to **22 zones**, using **ZXM2 Expansion Modules**. See page 23.

Compatible HVAC Systems

The UZC4 will Control 2, 3 & 4 stage Conventional, GeoThermal or Dual Fuel Heat pumps, without the need for dual fuel kits. Also single or multi-stage Gas, Oil, & Hydronic HVAC systems, with single or two stage cooling and Constant or Variable speed fan systems.

Compatible Thermostats

Compatible with most Off the shelf 1 or 2 stage Conventional Heat/Cool or Heat Pump Thermostats. All Mechanical, Digital/Electronic, Dual Mode, and Internet Compatible Thermostats that operate on 24vac. Battery powered or Power robbing thermostats that draw less than 20 ma of current are also compatible. Zone 1 will accept One Zone Mode, Carbon Dioxide Safety and Auxiliary/Dehumidify mode inputs. See pages 9-11 & 14-17 for details.

Automatic Heat/Cool Changeover

The UZC4 Zone system features automatic changeover from any thermostat allowing for individual zone comfort from the HVAC system.

Status LED

The STATUS LED pulses as a steady heart beat to indicate active Micro-processor status.

System LEDs

On board Multi-colored LED's will illuminate to indicate system status, HVAC system mode, and active / inactive zone identification. See page 22 for details.

Damper LEDs

Damper 1 thru Damper 22 green LEDs will indicate which zone dampers are demanded to energize Open or Closed.

Operating Power

INPUT VOLTAGE: 19-30VAC 60 Hz Transformer 40-100VA MAX. NEC Class 2.
CURRENT DRAW: Max 22VA @ 24VAC.
OVER-CURRENT PROTECTION: 4.0 amp or 100VA.

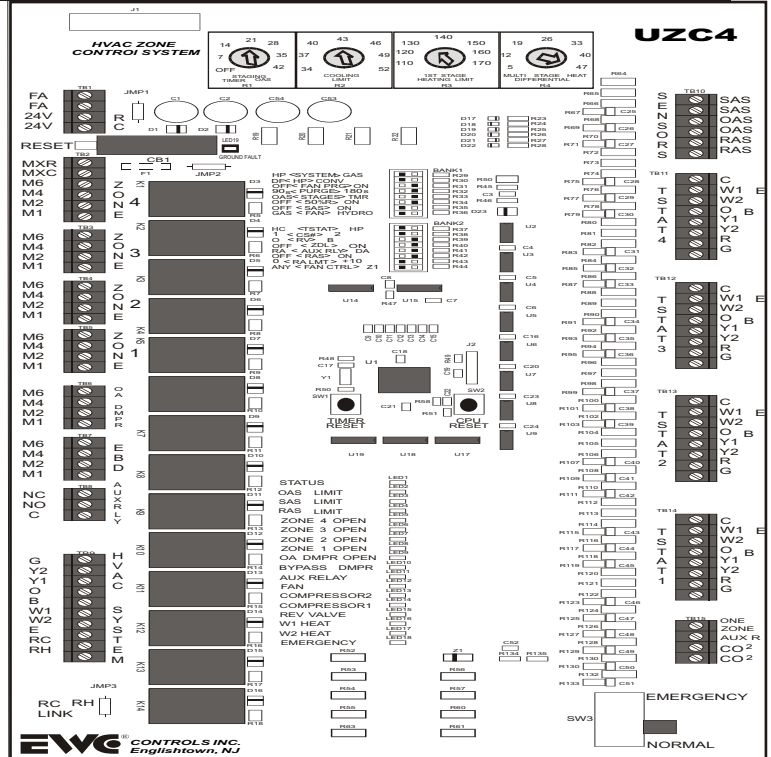

Figure 1.

Box Contents

- * UZC4 Zone Control Panel
- * Supply Air Sensor
- * Technical Bulletin TB221
- * Mounting Hardware

Manual and Automatic Thermal Circuit Breakers

The main UZC4 module has a Manual Reset circuit breaker with a Ground Fault Indicator that protects all connected modules and thermostat circuitry. All modules have separate damper motor Thermal Breakers too. They protect the damper motor circuitry from shorts in the field wiring. The breakers will not protect against shorts in the HVAC system wiring.

CAUTION: When the thermal breaker is tripped it will get quite hot. To reset the breaker: Shut off power to the panel. Find and repair the short. Restore the 24VAC power.

Operating Conditions

TEMPERATURE: -20° to 160°F (-29° to 71°C)
HUMIDITY: 0% - 95% RH Non-Condensing.

Indoor Fan Control

The UZC4 allows constant operation of the Indoor Fan by Thermostat #1 only, or by each individual thermostat. When controlled by thermostat #1, All Zone dampers will respond. When controlled individually, Zones not calling for continuous fan will close.

UZC4 STANDARD FIRMWARE AND HARDWARE FEATURES

Indoor Fan Control During Heating

A dip switch is provided to enable automatic fan operation in heat mode. Useful for straight electric heat or hydronic heat applications.
NOTE: Fan mode is automatically set when Heat Pump is selected.

Built-In Timer Settings

The panel has built-in delay timers that insure safe & reliable operation.

Definitions are explained below

- ***Short Cycle Timer** 3 minutes - Fixed.
- ***Changeover Timer** 4 minutes - Fixed.
- ***Inter-stage Timer** 2 minutes - Fixed.
- ***Opposite Mode Delay Timer** 20 minutes - Fixed.
- ***Staging Timer OAS Setting** 7 to 42 minutes or 7 to 42 °F
- ***Supply / Return Air Limit Delay Timer** 3 minutes - Fixed.

*Short Cycle Timer

When all zone demands are satisfied, the panel will not resume the same mode operation for a minimum of 3 minutes.

*Changeover Timer

When a demand to Change Over has been honored. A 4 minute delay timer prevents the system from rapidly changing between Heat to Cool, or Cool to Heat mode.

*Inter-stage Timer

2 minute time delay that occurs between thermostatic demands to stage up or down.

*Opposite Mode Delay Timer

A 20 minute delay must expire, or all active zone(s) must satisfy, before the UZC4 will honor a thermostat demand to changeover to the opposite mode of system operation. The delay is fixed & cannot be changed or defeated.

*Staging Timer / OAS

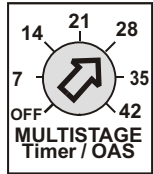

OFF or 7 to 42 minutes or 7 to 42 degrees F.

Use when Timer or Outside Air Changeover is required. See Page 7

*Supply/Return Air Limit Delay Timer

The time delay of 3 minutes must expire before the UZC4 will re-energize heat or cool mode. This occurs when the processor detects the supply or return air temperature is higher or lower than the Heat/Cool limit settings.

Cooling and Heating Limit Controls

The operational sequence of the limit controls depends upon the dip switch settings chosen on the UZC4 main module. Multistage Heat Pump sequence will differ from Conventional Gas/Electric.

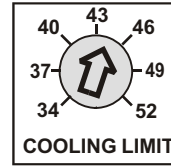

The Adjustable Cooling Limit potentiometer sets the supply air temperature at which the 1st & 2nd stage cooling is cycled off and the fan continues to run, allowing the coil to warm up.

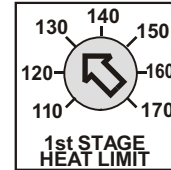

The Adjustable Heating Limit potentiometer sets the 1st or 2nd stage heat supply air temperature, at which the heating is cycled off and the fan continues to run, allowing the heat exchanger or coil to cool down.

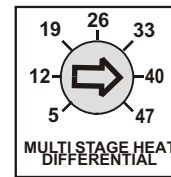

The Adjustable Multistage Heat differential potentiometer sets the 2nd and/or, 3rd, & 4th stage heat supply air temperature, at which the heating is cycled off and the fan continues to run, allowing the heat exchanger or coil to cool down.

Example:
Hi Temp. limit=130
Plus M. stg $\Delta T=40$
New limit $^{\circ}F=170$

NOTE: Allows the supply air sensor to be installed in the supply air plenum, regardless of the coil/heat exchanger configuration. Allows the installer to fine tune virtually any multistage heating system!

Timer Reset BUTTON



Momentarily pressing the TIMER RESET button will clear any Active Time Delay. This enables you to test and certify the installation faster.
NOTE: Do not use sharp objects to press the button. Use your finger tip or the eraser head of a pencil.

CPU Reset BUTTON



Press & Hold the SYSTEM RESET button for 5 seconds. That will reset the Main & Expansion modules on a UZC4 Zoning System.

NOTE: A three minute startup delay occurs whenever the CPU Reset button is pushed, upon any initial power up, or when a power failure has occurred.

Emergency Heat Switch

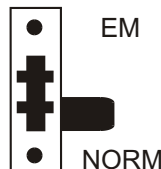

An On-Board Switch is provided that allows the user to set the system to the Emergency heat mode. *This switch is shown in the NORMAL position.*

NOTE: An Emergency terminal is also provided at every Thermostat terminal block, allowing Heat Pump Thermostats to be connected to every zone.

UZC4 ADVANCED FIRMWARE AND HARDWARE FEATURES CONTINUED

*FIRE ALARM INTERLOCK FEATURE

The UZC4 includes a Fire Alarm system interlock feature.

Wire the UZC4 into your building Fire Alarm system, and achieve full HVAC system shutdown, and Closure of all Duct dampers, in the event of Fire Mode Activation.

The circuit is normally closed and must open to activate this mode. A Fail Safe dry contact is required on the Fire Alarm System.

When the Fire alarm system resets to normal, the UZC4 will also resume normal operation. Clip the on-board jumper and wire as shown on page 17.

ULTRA-ZONE™ Building Code Compliant Support

Fire Alarm Activation Over-rides ALL functions and features

All Connected Dampers will close and the HVAC system will shut down

*Demand Based Ventilation

The UZC4 includes a Carbon Dioxide and Fresh Air interface feature.

Wire the UZC4 up to a separate CO2 Monitor with auxiliary dry contacts. When the CO2 Monitor activates, the UZC4 will open a fresh air damper connected to it's OA damper terminal block, and start the HVAC system fan.

The circuit is normally open and must close to activate this mode. A normally open dry contact is required on the CO2 Monitor or Fresh air Timer or Other Device.

When the CO2 monitor resets to a normal CO2 level, the UZC4 will close the fresh air /auxiliary damper.

Other external dry contact devices can be connected to the CO2 terminals such as a Manual Switch, Enthalpy Control, or ClockTimer. See page 16.

NOTE: Cooling & Heating operations are not affected by activation of this feature.

NOTE: Activation of the Fire Alarm Interlock feature will over-ride the CO2 Monitor feature.

CO2 MONITOR & FRESH AIR INTERFACE FEATURE

ULTRA-ZONE™ Building Code Compliant Support

This feature is not affected by Heat/Cool Operations

Fire Alarm Activation Over-rides this feature

ULTRA-ZONE™ AUXILIARY or DeHUMIDIFY INTERFACE RELAY

Enhanced Comfort Solution

Auxiliary "dry" SPDT output

This feature is affected by Heat/Cool Operations

Fire Alarm Activation Over-rides this feature

The UZC4 includes an Auxiliary Interface Input and SPDT action Dry Contact Output. This allows the Installer to connect various Auxiliary controls such as Humidify or DeHumidify controls. Simply connect the Controlled Device or Circuit to the "Output" dry contacts and achieve integrated control without 3rd party isolating relays.

See Page 14 and 15 for example control and wiring solutions.

The Auxiliary input logic can be field selected as (DA) Direct Acting to humidify or (RA) Reverse Acting to Dehumidify.

The UZC4 activates a unique algorithm to rapidly de-humidify the home without over-cooling it. See page 14.

ULTRA-ZONE™ ELECTRONIC BYPASS DAMPER SUPPORT FEATURE

Enhanced Airflow Solution

Fire Alarm Activation Over-rides this feature

The UZC4 includes support for an Electronic Bypass Damper.

Wire up a EWC Model "EBD" Bypass Damper to achieve precise control of the HVAC system static pressure and bypass damper operations.

Wire up the Model "EBD" damper as shown on page 17.

The UZC4 defaults the Bypass Damper to the "Open" position during "IDLE" periods. It will also maintain that position for 45 seconds; at the start of any thermostat demand for Heating, Cooling, or Fan only Operation.

The 45 second time delay allows a constant or variable speed fan to start in a "Quiet Mode" and does away with noisy air duct velocities upon system startup.

A Latent cooling effect is also achieved by using this feature.

After 45 seconds the UZC4 will release control of the system static pressure to the EBD diaphragm control and a gradual increase in system static pressure is achieved. **NOTE:** The UZC4 will not resume control of the "EBD", until the next "IDLE" period begins.

ULTRAZONE™ RETURN AIR MONITORING FEATURE

Enhanced
HVAC System
Safety and
Energy
Savings
Solution

Note: If this feature is "Enabled" but the "RAS" is not connected or is not detected; The "RAS" LED will blink rapidly as a warning and The UZC4 will not allow RAS operations to occur.

Note: When the Return Air sensor detects a return air temperature between the Stage Up Value and the Stage Down Value, the "RAS" LED will blink slowly as a warning. The UZC4 will also hold at the current staging until the system status changes sufficiently to allow a stage up or down.

The UZC4 includes a **RETURN AIR TEMPERATURE SENSING** feature.

Connect an OPTIONAL Return Air Sensor (#RAS) to the UZC4 and achieve the ability to STAGE DOWN the HVAC system if the return air temperature exceeds the return air temperature limit set points. **Set the "RAS" Dipswitch #6 to the "ON" position, and choose either (0) or (+10) at the "RA LIMIT" Dipswitch #7.** Both switches are located on the Dipswitch Bank#2.

The UZC4 will now monitor the return air temperature and allow Stage up, or if necessary Stage Down the cooling or heating operation to maintain a return air temperature within the following values. As stated above, choose either (0) to accept the default return air limit values for your particular HVAC system or choose (+10) to offset the default values 10 degrees higher. **Note:** *The (+10) offset applies to heating operations only. The default return air temperature limit set points for cooling operations cannot be offset.*

RETURN AIR LIMITS DURING HEATING CYCLE FOR HEAT PUMPS ONLY:

Default (0) set points:

If the Return Air temperature is:

80 degree F. or below, Stage Up is allowed.

105 degree F. or above, Stage Down is forced.

Default (+10) set points:

If the Return Air temperature is:

90 degree F. or below, Stage Up is allowed.

115 degree F. or above, Stage Down is forced.

RETURN AIR LIMITS DURING HEATING CYCLES FOR GAS, OIL, STRAIGHT ELECTRIC:

Default (0) set points:

If the Return Air temperature is:

80 degree F. or below, Stage Up is allowed.

115 degree F. or above, Stage Down is forced.

Default (+10) set points:

If the Return Air temperature is:

90 degree F. or below, Stage Up is allowed.

125 degree F. or above, Stage Down is forced.

RETURN AIR LIMITS DURING COOLING CYCLES FOR ALL HVAC SYSTEM TYPES:

Default (0) set points:

If the Return Air temperature is:

65 degree F. or above, Stage Up is allowed.

55 degree F. or below, Stage Down is forced.

Default +10 applies to heating operations only.

The Return Air Sensing Feature cannot cycle the 1st stage equipment off-line. It can only force a Stage Down when the equipment is in 2nd stage cool or 2nd, 3rd, or 4th stage heat, and the selected return air set points above have been exceeded. The Supply Air Sensing feature is the only monitor that can cycle the 1st stage equipment off-line.

A three minute delay will occur after a forced stage down. If a stage up demand is present, the UZC4 will allow the stage up to re-occur when the three minute delay has expired and the return air temperature is back to normal.

The UZC4 will automatically adapt to the "GAS,OIL,ELECTRIC" set points when a Heat Pump system stages up to Fuel or Auxiliary mode.

This powerful feature will enhance the efficiency of your Zoned HVAC system and protect the equipment from excessive bypass temperatures during low load conditions.

MODULE TO MODULE FACTORY POWER WIRING

The UZC4 includes Factory Power Wiring on all expanded systems. The 24 vac power to the expansion modules is fed through the bus cable. The bus cable feeds power to all module processors & thermostats. *Damper Motor terminal blocks are isolated and powered separately.* This simplifies your wiring, reduces the chances of polarity reversal and allows more connected dampers per zone.

DIRECT DUAL FUEL COMPATIBLE FIRMWARE

The UZC4 is fully compatible with Dual Fuel Heat Pumps, and other Hybrid HVAC systems. *Dual Fuel kits are not required.* Select staging based on Adjustable Time Delay, an Optional Outside Air temperature Sensor, or allow the thermostats to control staging. The intelligent firmware does the rest.

RAPID DE-HUMIDIFY FIRMWARE

The UZC4 will perform a unique de-humidify function when a demand to de-humidify is detected at the Auxiliary Input terminal. The UZC4 will energize the Emergency heat relay to activate one electric strip bank at the same time the Y1 cool is active, so long as the demand to de-humidify is detected. *This powerful feature will rapidly de-humidify your home, and tempers (reheats) the supply air to prevent over-cooling. See Page 14 for details.*

CO2 DEMAND BASED VENTILATION SUPPORT

The UZC4 includes support for Demand Based Ventilation Control scenarios. Designed to help meet or exceed local building codes and ASHRAE ventilation standards. Simply connect your CO2 Monitor and a Fresh Air damper to the UZC4.

-
- * 7 TO 42 MINUTE STAGE UP TIME DELAY SETTINGS
 - * 7 TO 42 DEGREE F. OUTSIDE AIR CHANGEOVER
 - * MULTI- STAGE HEAT ADJUSTABLE LIMIT CONTROL
 - * ELECTRONIC BYPASS DAMPER SUPPORT
 - * AUXILARY MULTI-FUNCTION SUPPORT RELAY

- *ZONE DEMAND LIMITING FEATURE
- * STATUS LED's ARE INCLUDED ON ALL MODULES
- *ONE ZONE MODE SETBACK CAPABILITY
- * SIMPLIFIED WIRING AND SYSTEM SETUP
- * FIRE ALARM INTERFACE

THERMOSTATIC DEMAND STAGE UP ON ALL ZONES

The UZC4 is the first Zone Control System to allow 4 stage thermostats to be connected to all zones

The UZC4 is capable of numerous staging sequences depending on the type of HVAC system being controlled, the type of thermostats connected, and the programmed staging sequence you desire.

As always you can still control a multi-stage HVAC system using inexpensive single stage thermostats and sequence the staging by on-board adjustable time delay, or by using an optional outdoor air sensor (OAS) and sequence the staging via an outdoor air set point.

You can still control a state of the art multi-stage Heat Pump using single or two stage conventional thermostats and sequence the staging by time delay or outside air set point.

You can choose to control most any multi-stage Heat Pump or Conventional HVAC system with OEM multi-stage thermostats on all zones. The UZC4 can be programmed to stage up or down based on the thermostat inputs from each zone. The UZC4 allows a level of versatility that has never before been offered by any zoning company. You can choose to install 3 or 4 stage thermostats on the largest zones, 2 stage thermostats on medium sized zones and single stage thermostats on the small zones.

To achieve staging via thermostatic demand only; Choose (TMR) Timer setting on Dipswitch #5 Bank 1 And then set the Multi-Stage Timer setting to (0) Zero. Setting the Timer to zero disables Timed Staging and the UZC4 will stage up or down only when the thermostat(s) demand it.

Selecting the Options Using the DIP Switches

***FS = Factory Settings

SWITCH LEGEND

_{FS} HP < SYSTEM > GAS
 DF < HP > CONV _{FS}
_{FS} OFF < FAN PRG > ON
 90s < PURGE > 180s _{FS}
 OAS < STAGES > TMR _{FS}
_{FS} OFF < 50% R > ON
_{FS} OFF < SAS > ON
_{FS} GAS < FAN > HYDRO

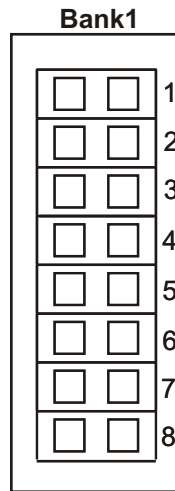

RECORD YOUR DIP SWITCH SETTINGS HERE

Programming and setting up the UZC4 is very easy! Check the **Switch Legend** and refer to the following pages for an explanation of each dip switch function and choose your settings. Some functions may not apply to your application. **Use a pencil to fill in the square & record your settings.** If the settings get changed later on, you will have a record of the original settings. **NOTE:** When you choose "HP" at switch #1, Bank 1, the fan mode is automatically set for you. There is no need to move switch #8, Bank1. Leave it in the "GAS" factory setting.

HC < TSTATS > HP _{FS}
_{FS} 1 < CS# > 2
_{FS} 0 < RV > B
_{FS} OFF < ZDL > ON
 RA < AUX RLY > DA _{FS}
_{FS} OFF < RAS > ON
_{FS} 0 < RA LIMIT > +10
_{FS} ANY < FAN CTRL > Z1

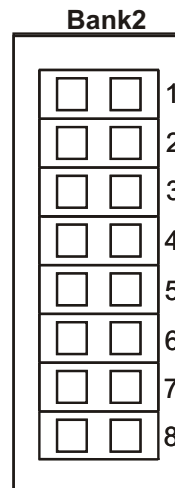

RECORD YOUR DIP SWITCH SETTINGS HERE

Detailed explanations of each Dip Switch Function are included on the following pages. Please study and familiarize yourself with all of the functions and features, prior to activating the Zoned HVAC system. Not all features will apply to your application.

The UZC4 comes from the factory pre-set to operate a 2 stage Heat Pump using heat pump thermostats to control the staging.

Failure to properly set all dip switches to the correct and/or desired positions will result in improper operation of the controlled HVAC System.

Please read and study the entire Technical Bulletin and if necessary, Call the EWC Technical Support Hotline when assistance is required.

Leave this Technical Bulletin with the Home or Building Owner for future reference.

CONTINUED ON NEXT PAGE...

Selecting the Options Using the DIP Switches - BANK1

1 HP < SYSTEM > GAS

Choose the type of HVAC system you want to control. Select **HP**, if your system is any type of heat pump. Select **GAS**, if your system is a any type of Gas / Oil furnace, or any straight Electric furnace or Hydronic (hot water / steam) heating system.

2 DF < HP > CONV

If you chose "HP" at switch #1, then choose the type of Heat Pump you want to control. Select **DF**, if your system is a Dual Fuel heat pump with Gas or Oil furnace backup heat. Select **CONV**, if your system is a Conventional heat pump with Electric resistance backup / supplemental heat. Also applies to Ground source / Geothermal heat pumps with Electric backup heat.

3 OFF < FAN PRG > ON

Select **ON**, if you want the UZC4 to force the indoor blower ON at the end of a heat/cool call to assist the zone purge cycle. **Selecting OFF** will allow the HVAC system to operate the indoor blower, without interference from the UZC4.

4 90S < PURGE > 180S

Select **90S or 180S**, if you want the zone dampers to hold position for 90 seconds or 180 seconds at the end of any heat or cool call. This allows the HVAC system to purge the remaining hot or cold air, into the zone(s) that were calling for it.

5 OAS < STAGES > TMR

Select **OAS**, if you want to **delay multi-stage operations based on the outside air temperature sensor**. Select **TIMER**, if you want to delay stage up based on the adjustable on-board timer. Both features are very useful when using single stage thermostats on all zones. **NOTE1:** Y2/W2 stage up defaults to a 30 minute delay, when OAS is chosen. **NOTE2:** An optional Outside Air Sensor (Part#OAS) is required to use the OAS feature. **NOTE3:** Thermostat demands to **stage up**, will always over-ride the Timer or OAS staging operations, Unless the 50% rule has been enabled, or the Return Air temperature limit has been exceeded. **NOTE4:** Thermostatic demands to Stage Down will be honored unless the Timer is also in use. **NOTE5: Disable the Timer by setting to OFF, and the UZC4 will obey Stage up & Stage down demands via the thermostats only!**

6 OFF < 50% RULE > ON

Select **OFF**, if you **do not** want to inhibit 2nd stage compressor cooling/heating operations based on the total number of zones calling. Select **ON**, if you **want** to inhibit 2nd stage compressor cooling/heating operations based on the total number of zones calling. *Half or more of the total number of thermostats must be calling or stage up will not occur.* **NOTE 1:** In All Modes, the 50% rule occurs between Y1 and Y2. **NOTE2:** In Gas mode the 50% rule occurs between W1 &W2. **NOTE3:** Emergency mode is never affected by the 50% rule.

7 OFF < SAS > ON

Select **OFF**, if you **do not** want to use the Supply air sensor included with the UZC4 Zone Control system. Select **ON**, if you **want** to use the included Supply air sensor. **Refer to the data sheet included with the Supply air sensor for installation details. Refer to page 2 for details on Supply air Sensing Limit Controls and settings. Mount the Supply Air Sensor in the discharge duct and/or plenum.**

8 GAS < FAN > HYDRONIC

Select **GAS**, if your HVAC system is a gas or oil forced air furnace. Select **HYDRONIC**, if your HVAC system has a hot water / steam coil, or straight electric heat with no indoor blower support. Useful when you need the indoor blower to run automatically in heat mode, just like it does in cool mode. **NOTE:** When you select **HP** on dip switch #1, the indoor fan mode is automatically set for you. If so, then leave this switch in the factory **GAS** setting.

CONTINUED ON NEXT PAGE...

Selecting the Options Using the DIP Switches - BANK2

1 HC < TSTAT > HP

Select the **type of thermostats** you want to use. Select **HC**, if your thermostats are the standard Heat/Cool type. Select **HP**, if your thermostats are Heat Pump types. **NOTE1:** You cannot mix thermostat types. **NOTE2:** You do not need HP thermostats to control a Heat Pump. **NOTE3:** Thermostat demands to **stage up**, will always over-ride the Timer or OAS staging operations, unless the 50% rule has been enabled. **NOTE4:** Thermostatic demands to **stage down** will be honored unless the Timer is in use.

IMPORTANT NOTE: The UZC4 Zone Control System allows Heat Pump or Conventional Multi-Stage thermostats to be wired to all Zones!

Thermostat demands to **stage up**, will always over-ride any programmed staging operation. The UZC4 will remain in Multi-stage mode until that terminal is de-energized. If this occurs in dual fuel mode or emergency mode, the UZC4 will stay in that mode until **all** Heating demands are satisfied. On the next heating cycle, the UZC4 will attempt to activate 1st stage heat unless, Emergency Mode is still active, or the outdoor temperature is low and OAS / DF has been selected. This comfort over-ride feature provides true versatility to your zoning system, and gives the homeowner comfort control capability over the system.

2 1 < CS# > 2

Choose the **number of Condensing Unit Stages** you want to control. Select **1**, if your CU has a **Y1** connection only. Select **2**, if your CU has a **Y1 & Y2** connection. **NOTE1:** This feature must be set correctly for proper Timed & Outdoor Air Sensor staging operations. **NOTE2:** Thermostat demands to **stage up**, will always Over-ride the Timer & OAS staging operations, unless the 50% rule has been enabled, or the Return air temperature limit has been exceeded. **NOTE3:** All **stage up** Operations depend upon the correct setting of this switch.

3 O < RV > B

Choose the **type of Reversing Valve** you want to control. Select **O**, if your heat pump reversing valve energizes in cooling and defaults to heat mode. Select **B**, if your reversing valve energizes in heating and defaults to cool mode. **NOTE:** The UZC4 will hold the "O" output or the "B" output continuously, even during idle periods, until a thermostatic demand to change modes is detected. **NOTE:** Proper setting of this switch is critical. The reversing valve will not function properly if this switch is not set correctly.

4 OFF < ZDL > ON

Select **ON** and the UZC4 will limit HVAC operations based on the total number of zones calling for conditioned air. 16% or 1/6 of the total number of zones (rounded up) must be calling for the same mode of operation, or the UZC4 will not activate the HVAC system. *This feature only activates at 8 or more zones. Select OFF if you do not want to utilize the Zone Demand Limiter feature.* **NOTE:** Zone 1 is not affected by this feature. Zone 1 demands are always honored. **ZDL example:** A zone system has 20 total zones and the ZDL feature is active; At least 4 zones must be calling for the same mode of operation (Heat or Cool) or the UZC4 will not activate the HVAC system. *18zone=3, 16zone=3, 14zone=3, 12zone=2, 10zone=2, 8zone=2.*

5 RA < AUX RLY > DA

Select the **control signal type you need, in order to activate your preferred Auxiliary Relay function.** Choose RA (Reverse Acting) for De-Humidification Control, or Choose DA (Direct Acting) for Humidification Control, depending on the control input signal you require. Then connect your controlled device or circuit to the SPDT dry output contacts and achieve integrated control without the need for 3rd party relays or specialty relays. **If this feature is not used, the switch must be in the DA position.** See Pages 14-16 for further information.

6 OFF < RAS > ON

If you connect an **OPTIONAL Return Air Sensor to the UZC4**, then Select **ON**, and Choose to use the default set points for Return Air Temperature Limit Operations, or choose to Offset those set points by 10 degrees higher at the next Dip Switch. **Refer to the data sheet included with the Return air sensor for installation details.** Mount the Return Air Sensor in the return air duct as close to the Blower intake as possible, or in the blower cabinet. Read page 4 for Operational details.

7 0 < RA LIMIT > +10

If you connect an **OPTIONAL Return Air Sensor** and **switch on** the "RAS" switch above; then choose "0" to accept the default set points for Return Air Temperature Limits, or choose "+10" to Offset the default set points 10 degrees higher. **Refer to the data sheet included with the Return air sensor for installation details.** Read page 4 for Operational details.

8 ANY < FAN CTRL > Z1

Select which thermostat(s) can activate a demand for Continuous Fan Operation. Choose "ANY", and the UZC4 will honor any thermostat demand to activate continuous fan, and only the dampers connected to that zone will open. All others will close. Choose "Z1", and the UZC4 will honor a demand to activate continuous fan from zone 1 only. All connected dampers on all zones will open. Demands to activate continuous fan from any other thermostat will be ignored. **NOTE:** Continuous Fan Operations will only occur when there are no active or pending heat or cool operations.

INSTALLATION INSTRUCTIONS and THERMOSTAT WIRING

Installation should be performed by qualified personnel only. Follow local & national electrical & mechanical codes. Use multi-conductor 18 awg solid copper conductors. Wire number to number or letter to letter on each control or device.

WARNING: THESE PANELS ARE DESIGNED FOR USE WITH 24-30vac. DO NOT USE OTHER VOLTAGES! USE CAUTION TO AVOID ELECTRIC SHOCK OR EQUIPMENT DAMAGE.

Mount the panel housing in a convenient location close to the Air Handler. Mounting hardware is provided. Use the knockouts provided on the panel housing as entryways into the housing. Strain relief fittings can be used if desired. Use care and do not damage the circuit board when making wire connections.

NOTE: The 24 vac power required to operate a UZC4 system must be supplied by a separate transformer. **WARNING! DO NOT use the 24 vac power supply from the HVAC manufacturer's equipment.**

NOTE: Unlike previous UZC series zone control systems, the UZC4 supplies power to all connected expansion modules. This improved design simplifies the installation wiring and reduces the possibility of polarity reversal or incorrect transformer phasing. The UZC4 does allow you to isolate and power up the damper terminal block separately for greater versatility.

POWER WIRING

A single 24vac, 40va UL Listed transformer can power the UZC4 Main module with one damper on each zone. A total of four zones and four dampers. See page 19 for more load and transformer data.

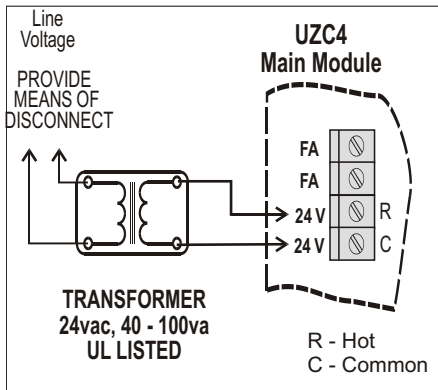

Figure 2. UZC4 Power wiring Supply

TYPICAL 1 HEAT / 1 COOL THERMOSTAT WIRING

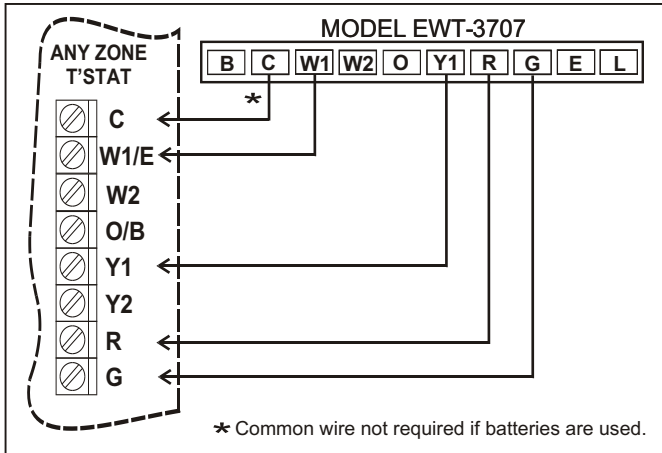

Figure 3. Model EWT-3707: Configured for 1 heat 1 cool (SS1 mode). Typical Gas, Oil or Hydronic System.

CONVENTIONAL 2 HEAT / 1 COOL THERMOSTAT

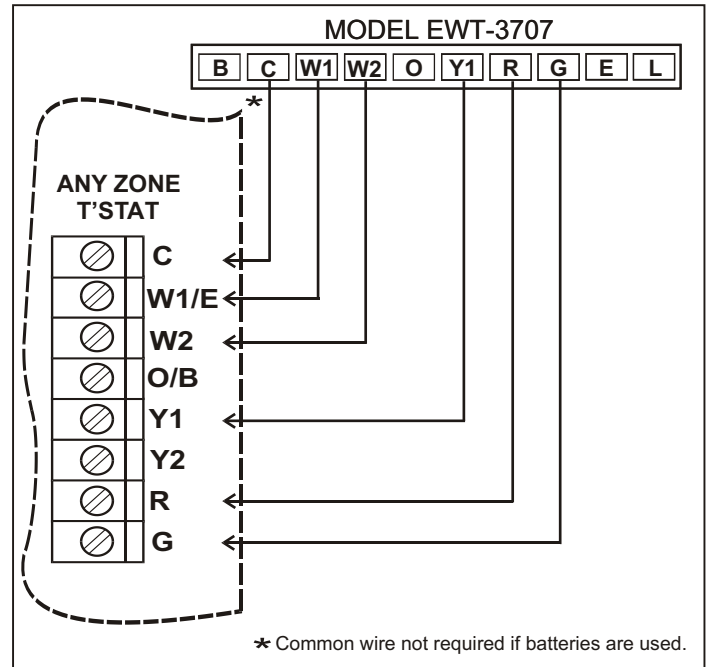

Figure 4. Model EWT-3707: Configured for typical 2 stage Gas or Electric heating system with 1 stage cooling.

CONVENTIONAL 2 HEAT / 2 COOL THERMOSTAT

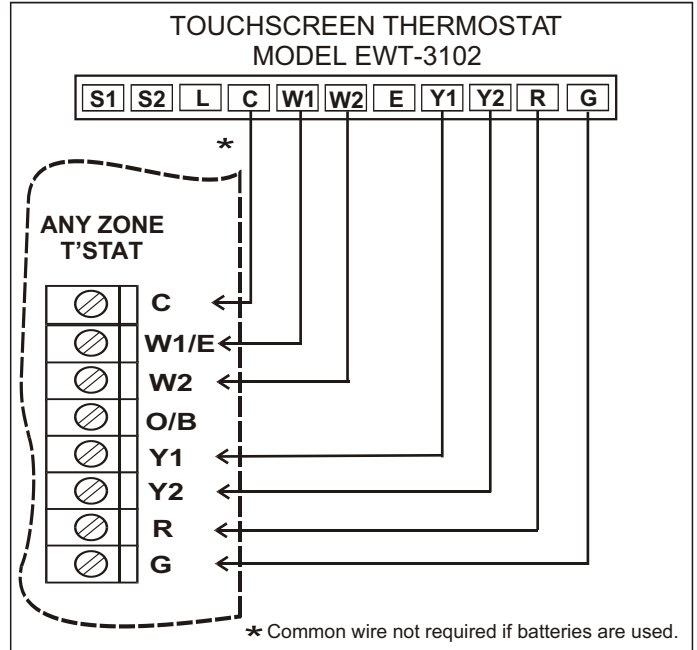

Figure 5. Model EWT-3102 : Configured for typical 2 stage Gas or Electric heating system with 2 stage cooling.

All of the preceding diagrams reflect conventional (Non-Heat Pump) thermostats, controlling conventional HVAC systems. However, the equipment being controlled does not have to be the conventional type. A heat pump system can be controlled using conventional thermostats. But you cannot control a conventional system using heat pump thermostats.

THERMOSTAT WIRING CONTINUED

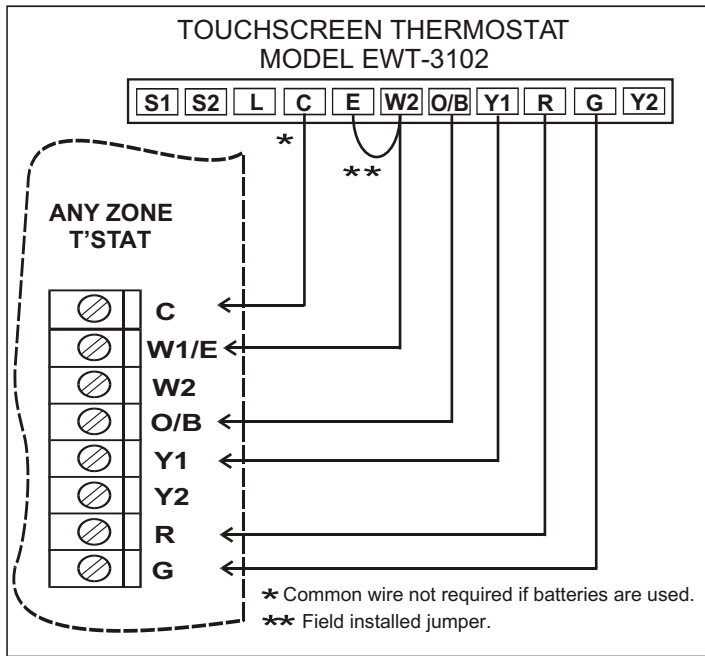

Figure 6. Model EWT-3102: Configured for 2 heat 1 cool heat pump (HP1 mode). See thermostat instructions for further details.

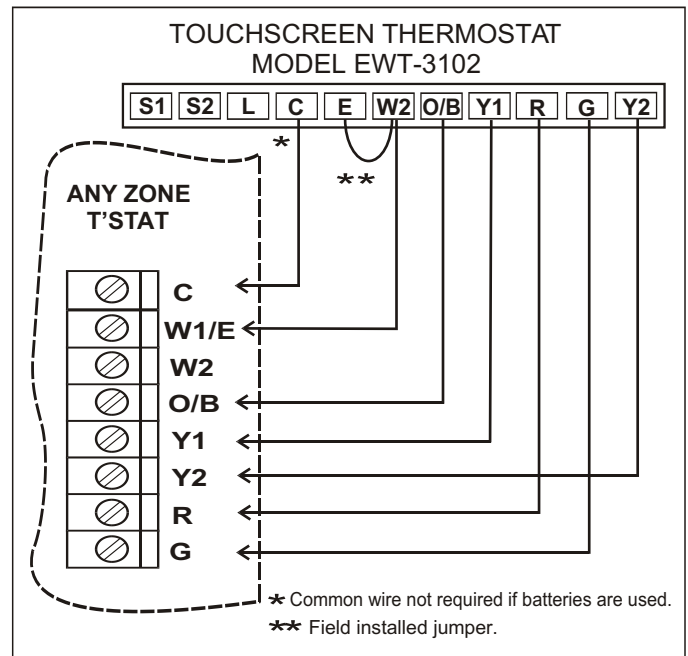

Figure 8. Model EWT-3102: Configured for 3 heat 2 cool heat pump (HP2 mode). See thermostat instructions for further details.

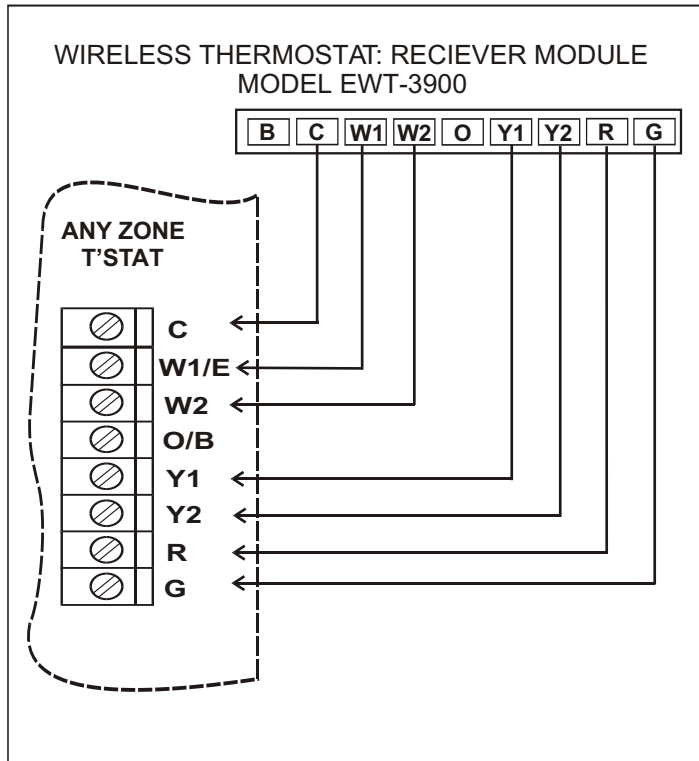

Figure 7. Model EWT-3900: Wireless Thermostat. Configured for 2 heat 2 cool (MS2 mode). See Thermostat instructions for further details.

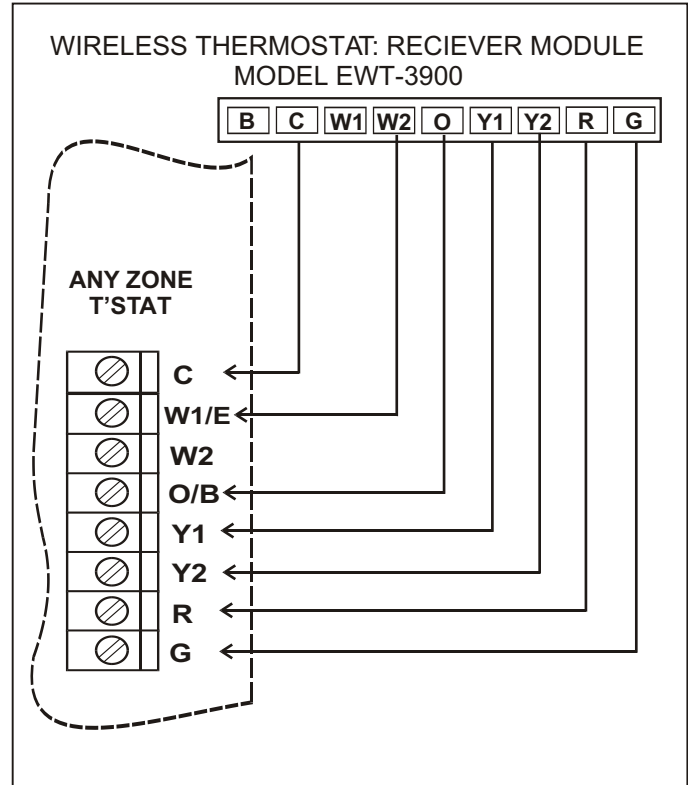

Figure 9. Model EWT-3900 Wireless Thermostat: Configured for 3 heat 2 cool heat pump (HP2 Mode). See thermostat instructions for further Details.

WIRING FOR RADIANT FLOOR HEAT

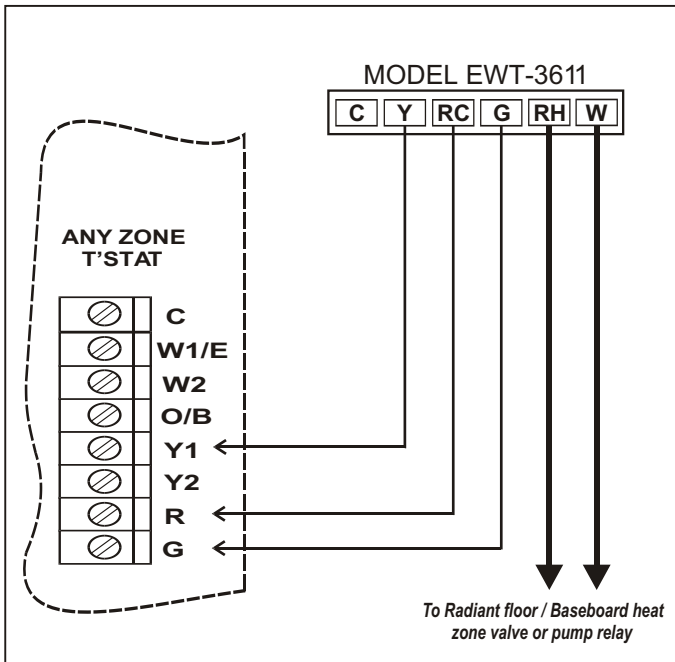

Figure 10. Wiring a split circuit thermostat to operate a Radiant floor heating or Baseboard heating Hydronic system. The UZC4 controls the cooling only, in this type of configuration.

HEAT PUMP MODE WITH DE-HUMIDIFICATION

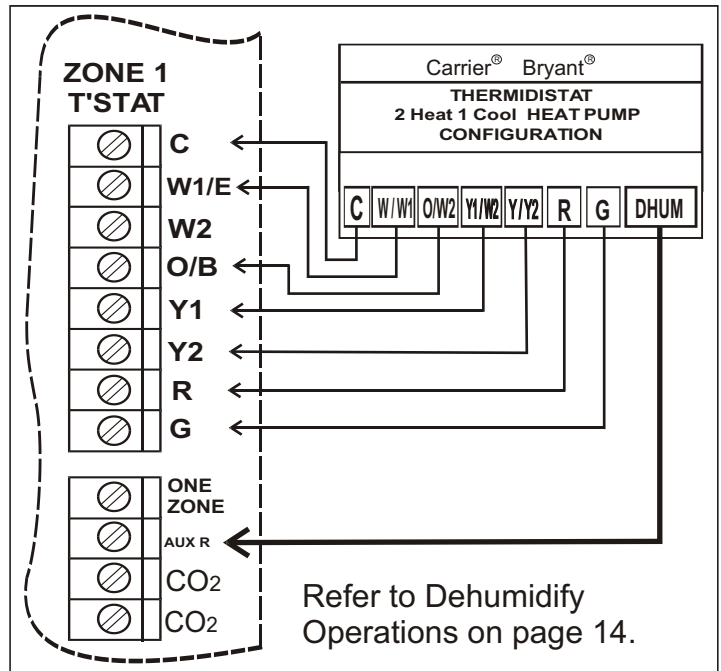

Figure 12. Wiring for typical 2 stage Heat, 1 stage cool Heat Pump. Diagram reflects De-humidification terminal wired to the Auxiliary input. For auxiliary output wiring see page 14. Auxiliary Relay Dip Switch #5, Bank #2, should be set to Reverse Acting. (RA)

WIRING FOR "ONE ZONE" MODE

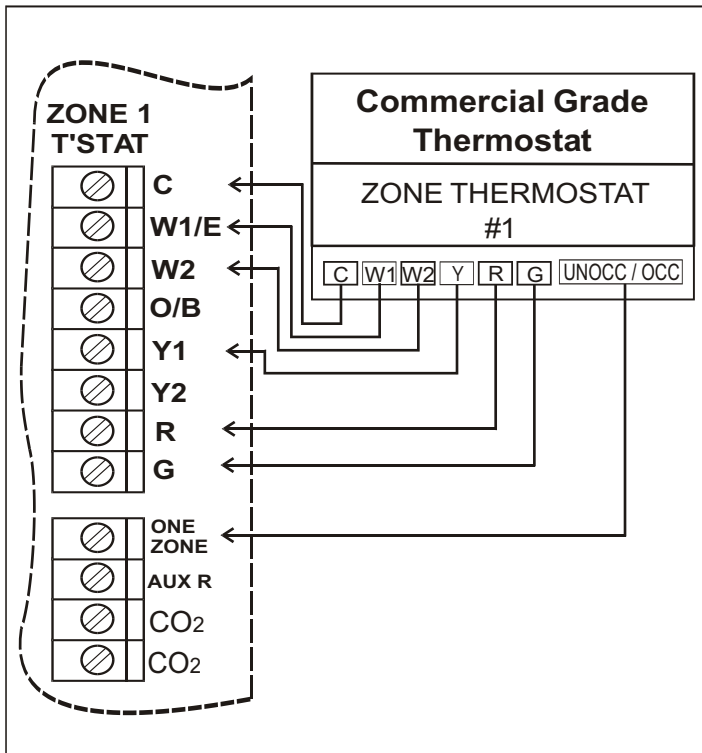

Figure 11. Wiring for automatic activation of "One Zone" mode using a commercial grade thermostat in Zone 1. Program or wire the thermostat to Energize (close contact) the One Zone Terminal and setback the temperature when the building is Unoccupied....When the building is Occupied, the thermostat will de-energize (open contact) the One Zone Terminal.

MODEL IZT-250 INTERNET THERMOSTAT

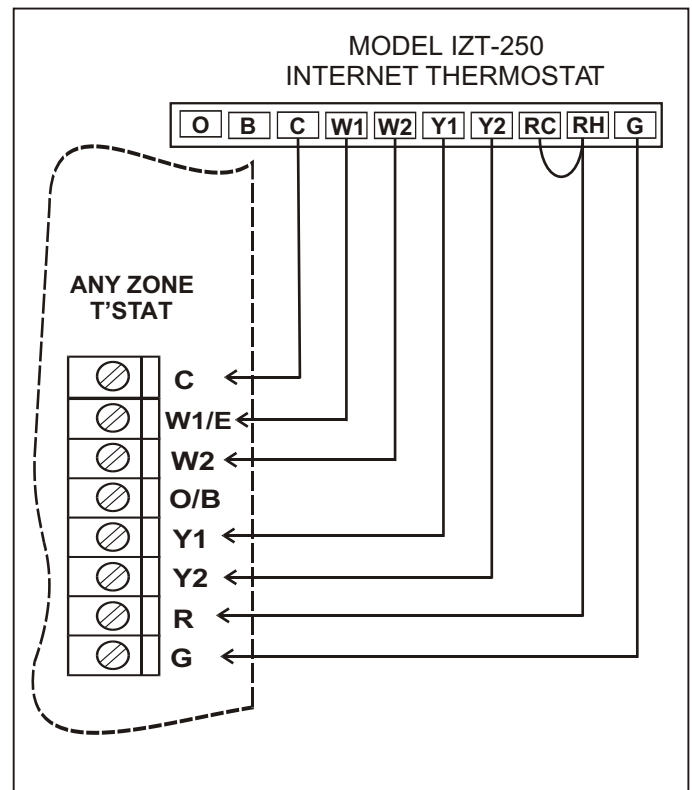

Figure 13. Model IZT-250 Internet Thermostat: Configured for 2 heat 2 cool. See thermostat instructions for further details.

HVAC SYSTEM WIRING

Single Transformer Gas/Oil Systems 1 or 2 Stage Heat

Typical gas / oil system with A/C.
A jumper wire between Rc and Rh is provided. There is no need to install a jumper.

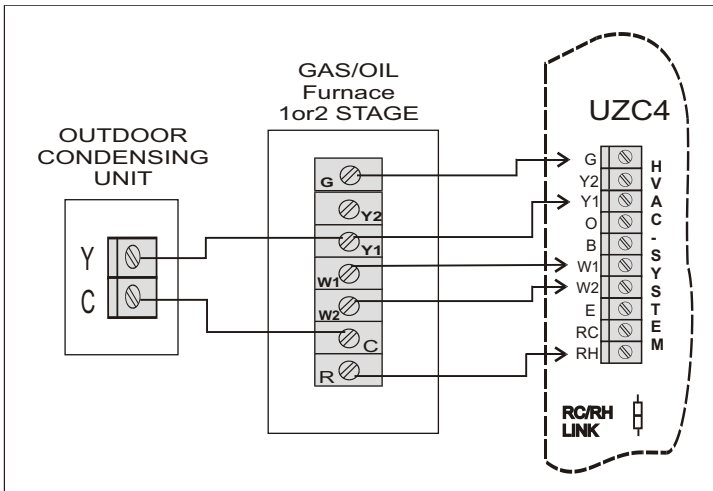

Figure 14. Single transformer Gas / A/C system.

Two Transformer Oil/ Hydro Systems

Wiring diagram for a typical oil burner, hydronic zone / Air handler with A/C.
Cut the Rc / Rh link on the UZC4 Panel for systems requiring isolation.

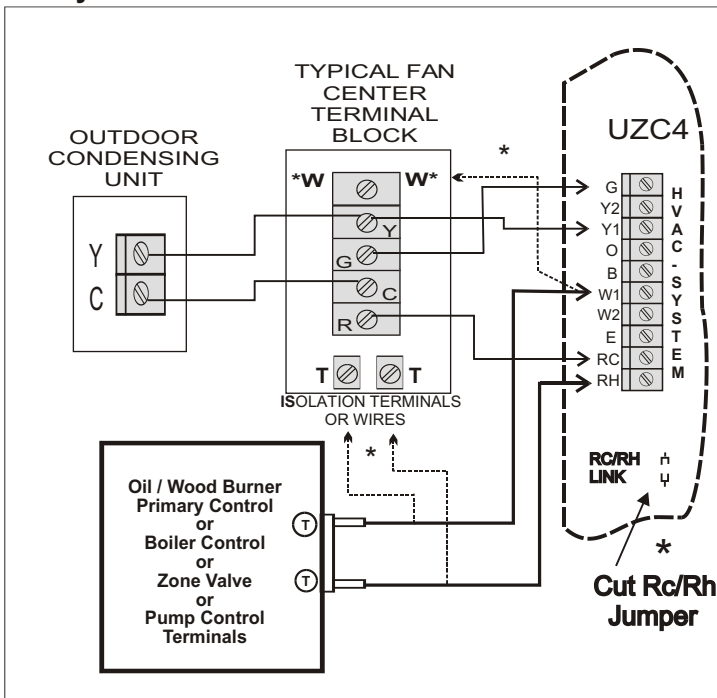

Figure 15. Two transformer Oil or Hydronic / A/C system.

*** Note:** Your Air Handler may include a W terminal. That means it may have it's own isolation circuit. If you can confirm this, simply connect the W1 terminal to the W terminal on the air handler. Do not cut the Rc / Rh jumper. Wire up your Oil Burner, Pump Control, or Hydronic Zone valve to the isolation terminals or wires provided in the air handler. (follow dashed lines) The fan is controlled via time delay relay inside the air handler, or set the UZC4 "FAN" Dip Switch to the "HYDRO" position.

Conventional 4 Stage Heat Pump with a "B" Type Reversing Valve

Typical heat pump system wiring with electric resistance backup heat. Wire up the reversing valve to either O or B, depending on your system type. Applies to air cooled or geothermal / ground source systems.

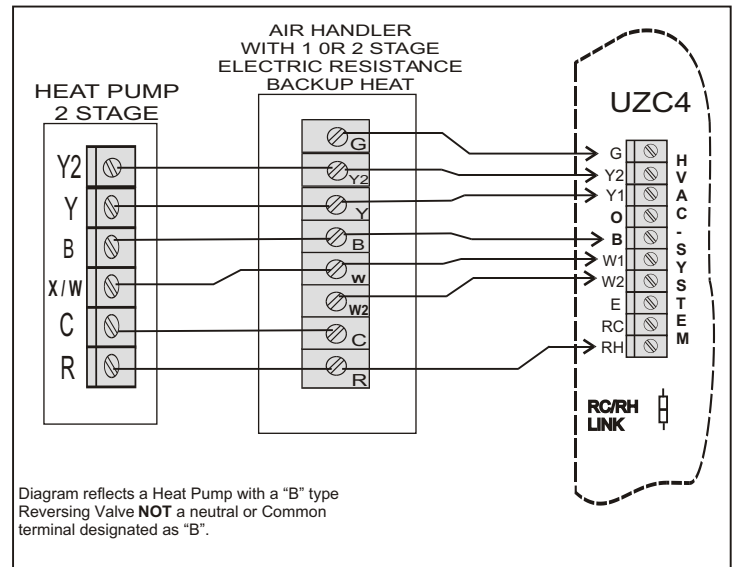

Diagram reflects a Heat Pump with a "B" type Reversing Valve NOT a neutral or Common terminal designated as "B".

Figure 16. Conventional Heat Pump System

Dual Fuel Heat Pump with "O" Type Reversing Valve

Hi Efficiency Heat Pump with built-in Outside Air Changeover Capability. The Heat Pump makes the decision to run the Furnace. Note that the UZC4 can still operate the furnace in Emergency Mode!

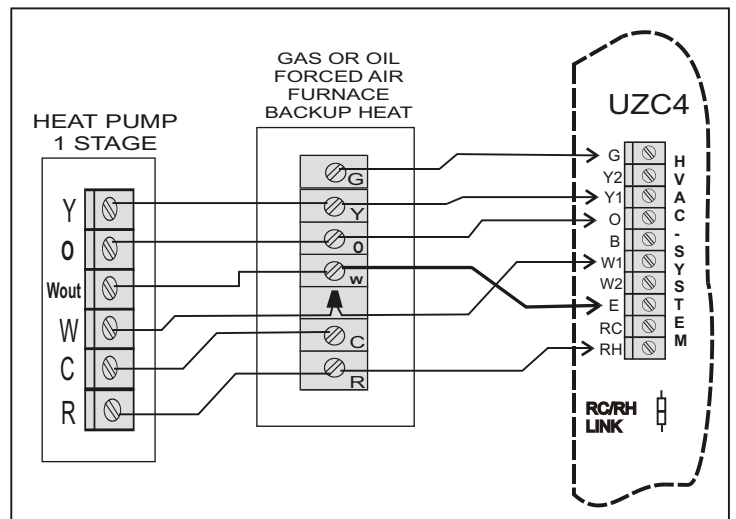

Figure 17. Single stage heat pump and single stage furnace.

Note that a Conventional & Dual fuel heat pump could wire up more or less the same. The difference is how staged heat operates. In a Conventional system, the indoor fan & the compressor continues to run when stage up occurs. In a Dual Fuel system, the indoor fan & the compressor shuts down when stage up occurs. The UZC4 will perform these functions automatically. All you have to do is set the dip switches to the correct settings. Select DF or CONV at dip switch #2, Bank 1. Choose to activate 2nd stage heat by TIMER or by OUTSIDE AIR TEMPERATURE. (Optional Sensor Required) You can also use Multi-stage thermostats in any or all Zones. When the thermostat stage up heat demand is satisfied, the UZC4 will stage down, unless DF/OAS has been selected and the outdoor temperature is lower than the OAS changeover setting. In that case the system will continue in FUEL mode, until all heating demands are fully satisfied. Your Heat Pump may be capable of making these decisions without the aid of the UZC4, in which case you may elect to wire your system as shown in figure 17.

SYSTEM WIRING CONTINUED

Typical A/C Split System 2 stage heat 2 stage cool

Typical 2 stage gas or straight electric furnace with 2 stage cooling. Choose "Timer" or "Outside Air Sensor" to delay 2nd stage, or use 2 stage T-stats on all zones.

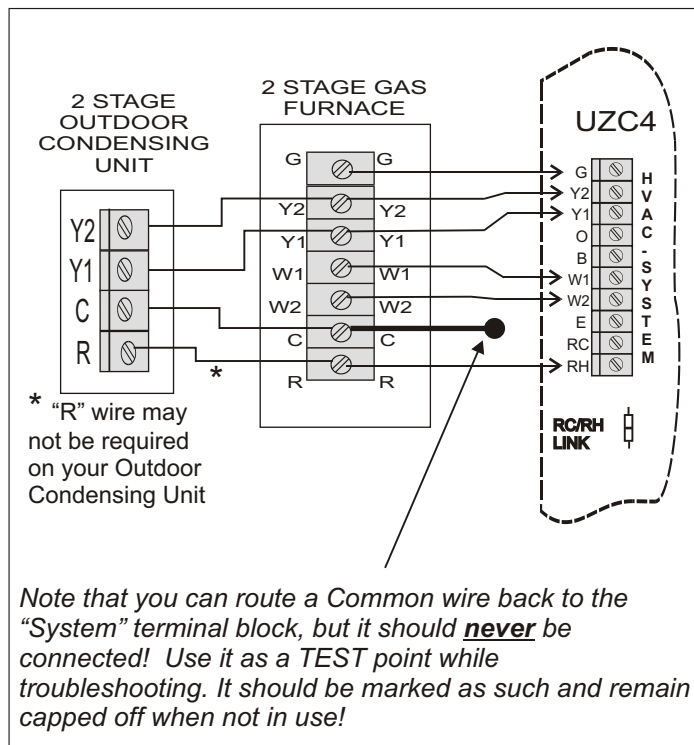

Figure 18. Single transformer 2 Stage Heat / AC system

HVAC system with OEM Voltage Control Circuitry

Some HVAC manufacturers are designing HVAC Systems with 5 - 18 vdc control circuits. Standard 24 vac thermostats will not work on these systems. These systems can only be controlled with their own thermostat. But the **SYSTEM** connections on a UZC4 are all dry contacts! Virtually any HVAC low voltage control circuit can be connected and controlled. All you have to do is ask the manufacturer which numbered terminals correspond to the standard terminals.

Theoretical diagram only shown below.

OEM Geothermal or Ground Source Packaged Heat Pump. 3 stage heat & 1 stage cool with "O" type reversing valve.

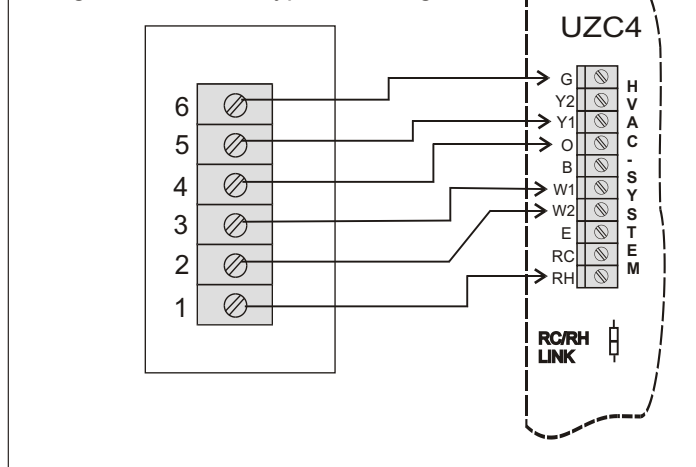

Figure 20. OEM system with 5 - 18 vdc control circuit.

High Efficiency Heat Pump. 3 or 4 Stage Heat and 2 Stage Cool

LUXAIRE® High Efficiency "Acclimate" Heat Pump System. Refer to Mfr's data for specific equipment dip switch settings and logical program settings. Set up the UZC4 to control the staging based on "Time" with single stage Conventional Thermostats. Or you can install 3 stage Heat Pump Thermostats on all zones.

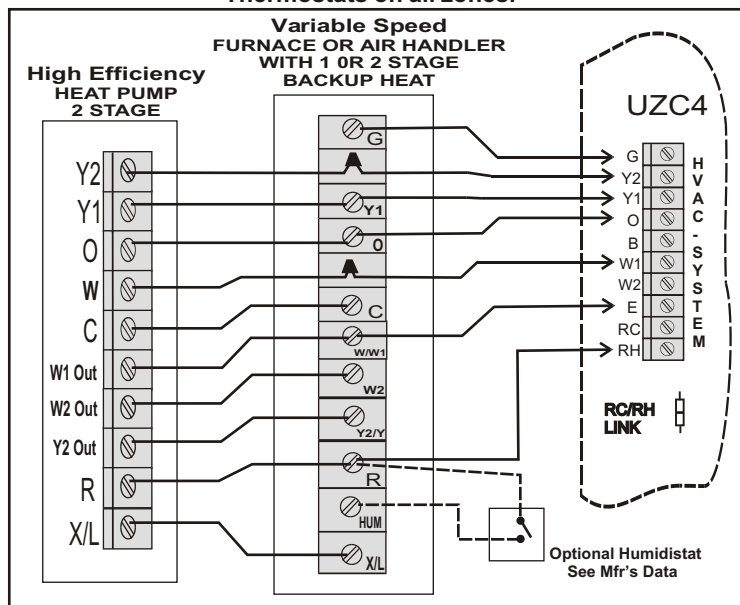

Figure 19. 3 or 4 Stage High Efficiency Heat Pump System

IMPORTANT NOTES:

HEAT PUMP EMERGENCY OPERATIONS:

Any Thermostat can demand Emergency Mode! When emergency mode is activated, the UZC4 will energize the "E" output terminal and the "W1" terminal. The "W2" terminal will also energize after a 3 minute delay. There is no need to jumper the "E" terminal to the "W" terminals. The UZC4 does this to ensure that the Emergency backup system energizes, regardless of which terminal it is connected to. In fact, the design of the UZC4 encourages you to separate up to three (3) electric strip banks, preventing large in-rush currents when all banks are tied together. This will also reserve at least one bank dedicated for Emergency mode and De-humidify/Reheat operations.

Make sure that you have correctly selected either "Dual Fuel" or "Conventional" Heat Pump to obtain the proper staging operations for your particular system.

Warning:

All of the wiring diagrams provided are general in nature and may not perfectly match your particular application. This is due to differences in the HVAC Mfr's terminal designations and functions! Variations on these diagrams and other System or Thermostat applications are available by contacting the EWC Technical Support Hotline, or visit our web site at www.ewccontrols.com

SYSTEM WIRING CONTINUED - Specialty Applications

The Auxiliary Feature can be used to activate DeHumidify Operations on Variable or Constant Speed HVAC Systems.

The UZC4 can be set up to control DeHumidify operations on most any Heat Pump or Conventional HVAC system. The UZC4 will also activate a unique Dehumidify Control Algorithm when the Dehumidify demand is detected. When a separate control calls for Dehumidification, the UZC4 will activate "Y1", "G" and the Auxiliary Relay, to signal the Air Handler to slow the fan down.

The UZC4 WILL ALSO energize the (E) Emergency output terminal to REHEAT the cold discharge air and Rapidly Dehumidify the home. Energizing the "E" during this cycle prevents over-cooling the home. A common Customer complaint with the DeHumidify cycle in these HVAC systems.

NOTE1: The UZC4 will not activate dehumidify operations unless the "Y1" (cool) signal is also detected at Zone 1.

NOTE2: A cooling or heating demand detected at any other zone can cause a delay to activate or will terminate the De-Humidify operations.

NOTE3: Dehumidify can only be achieved in (RA) Reverse acting mode.

NOTE4: Do not use this feature for commercial applications per ASHRAE 90.1-2013.

Using the UZC4's Auxiliary Feature to control Dehumidify Operations

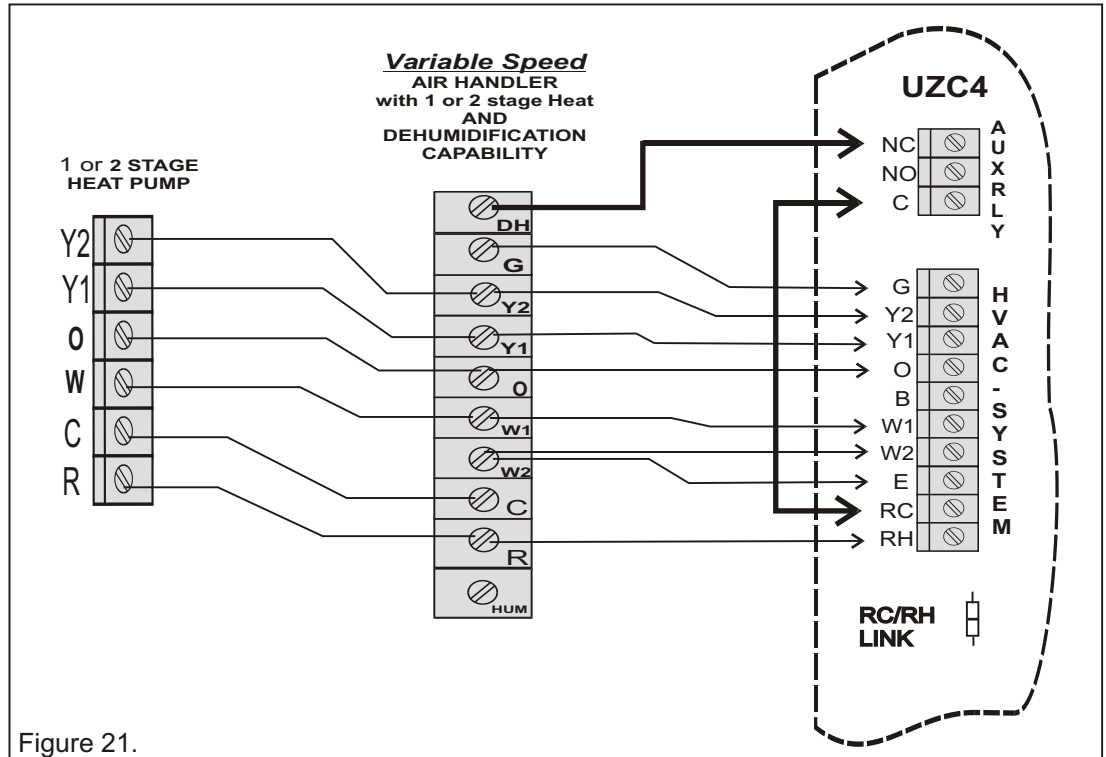

Figure 21.

Wiring for typical 4 stage Heat, 2 stage cool Heat Pump. Diagram reflects De-humidification terminal wired to the Auxiliary output (NC) Normally Closed terminal. Auxiliary Relay Dip Switch #5, Bank #2, should be set to (RA) Reverse Acting when using the type of control shown below.

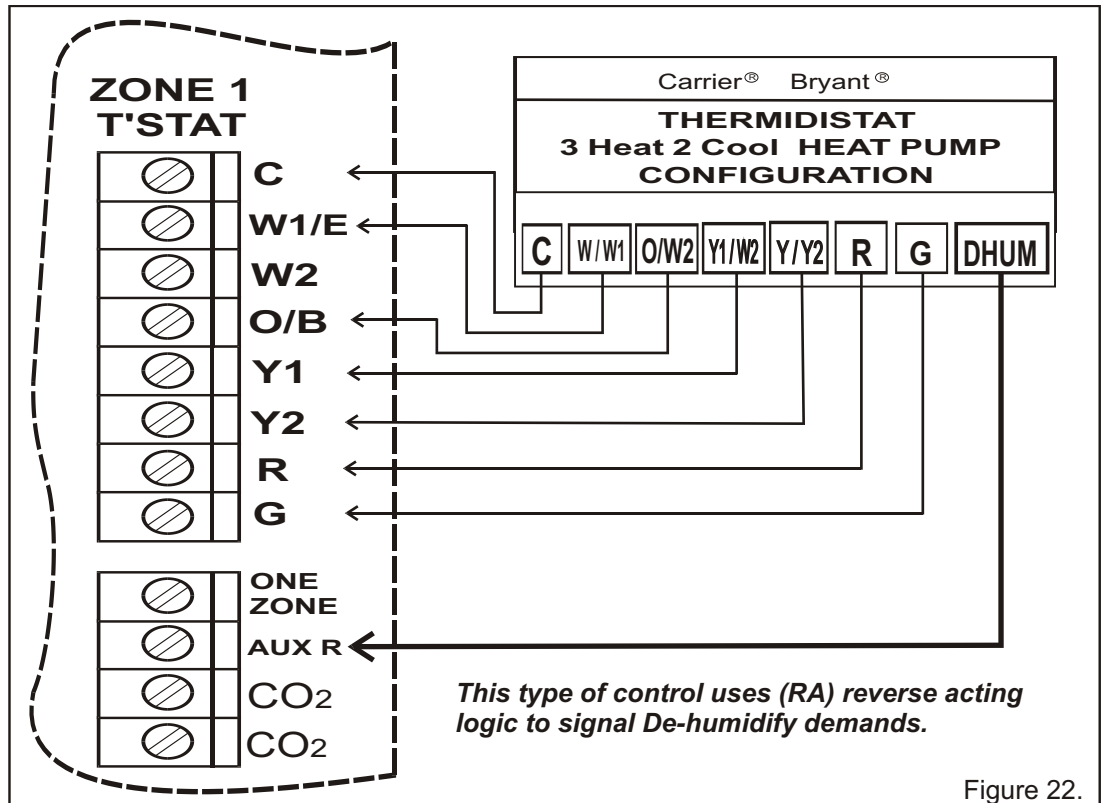

Figure 22.

Wiring for typical 3 stage Heat, 2 stage cool Heat Pump. Diagram reflects De-humidification terminal wired to the Auxiliary input. Auxiliary Relay Dip Switch #5, Bank #2, should be set to (RA) Reverse Acting. Contact EWC Controls Technical support or visit our web site for additional diagrams and alternate control methods to achieve De-humidification.

SYSTEM WIRING CONTINUED - Specialty Applications

Using the UZC4's Auxiliary Feature to control Fan Speed

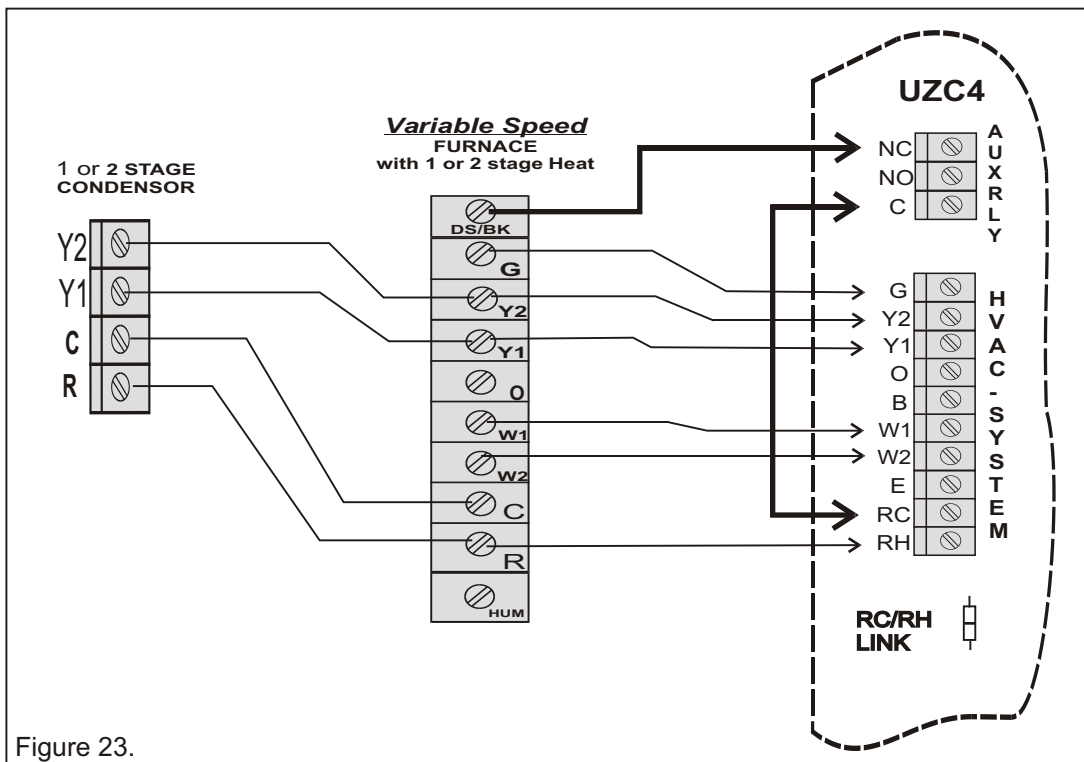

Figure 23.

Wiring for typical 2 stage Heat, 2 stage cool Gas Furnace.. Diagram reflects DS/BK terminal wired to the Auxiliary output (NC) Normally Closed terminal. Auxiliary Relay Dip Switch #5, Bank #2, should be set to (RA) Reverse Acting when using the type of control shown.

The Auxiliary Feature can also be used to Control the Fan speed based on the Number of Zones calling.

The UZC4 can be set up to control the fan speed on most any variable speed air handlers or furnaces during cooling operations. The UZC4 will lower the fan speed when 25% or less of the total zones are calling for cooling. When this occurs the UZC4 will activate the Auxiliary relay output which will de-energize the DS/BK terminal on the Forced air unit resulting in the blower running at a lower speed.

NOTE 1: A jumper is required across the R terminal on zone 1 and the AUX R terminal.

NOTE 2: Other configurations are available. Contact Technical Support for further information.

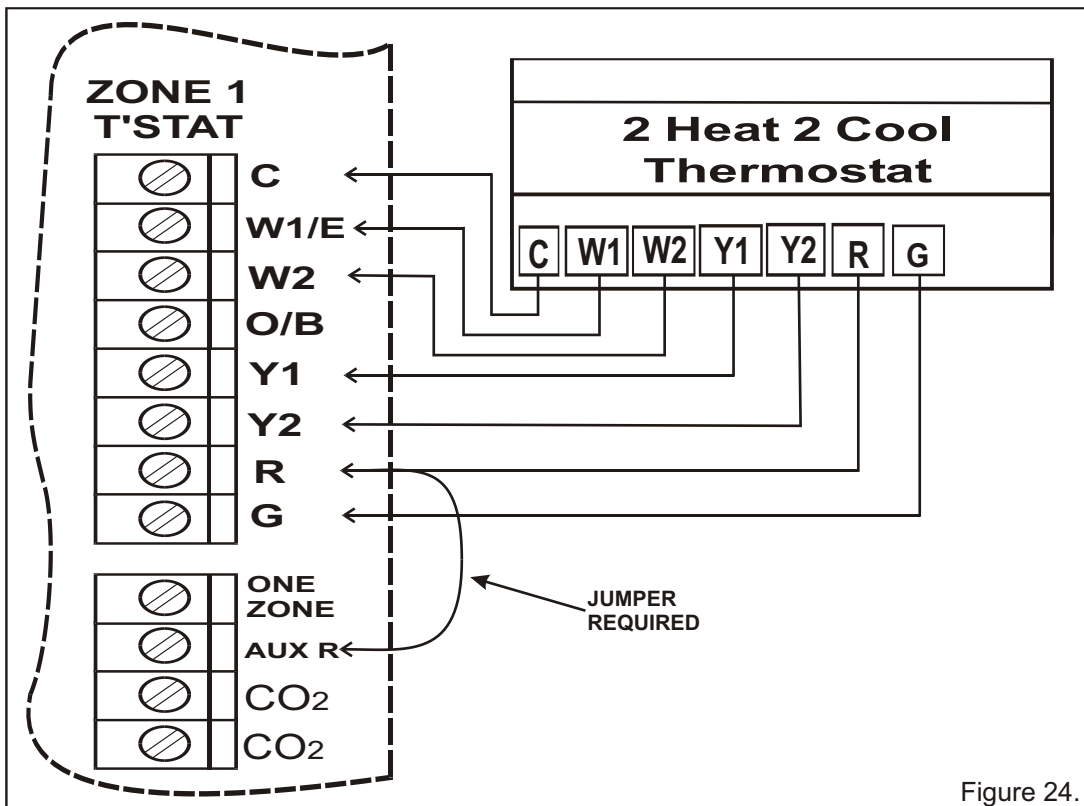

Figure 24.

Wiring for typical 2 stage Heat, 2 stage cool Thermostat. Diagram reflects AUX R terminal wired with a jumper to the R terminal. Auxiliary Relay Dip Switch #5, Bank #2, should be set to (RA) Reverse Acting.

SYSTEM WIRING CONTINUED - Specialty Applications

The Auxiliary Feature can be used to control Humidify Operations on any HVAC System.

Set the Auxiliary relay Dip Switch to Direct Acting and connect a dry contact Humidity Control to the "R" and "AUX R" terminals.

When the UZC4 detects a demand to Humidify, it will energize the Auxiliary Output Relay. The Auxiliary relay contacts are dry, so you can connect and control most any humidifier you want.

These drawings show an Ultra-Zone 072000 Smart

Humidistat connected to the Auxiliary Input, and an S2000/S2020 Steam Humidifier connected to the Auxiliary Output.

Refer to the Technical Bulletins on the Ultra-Zone S2000/S2020 and the 072000 Smart Humidistat for additional details.

The UZC4 humidity control logic allows a Humidity demand to occur at any time. There is no need for a Heating demand to occur first.

Bear this in mind when field wiring your system. You may have to interlock your Humidifier to run during a heating call only! Steam Humidifiers can run at any time and do not require a heating demand to occur first.

NOTE: Humidify operations can only be achieved in (DA) Direct acting mode.

Using the UZC4's Auxiliary Feature to control Humidify Operations

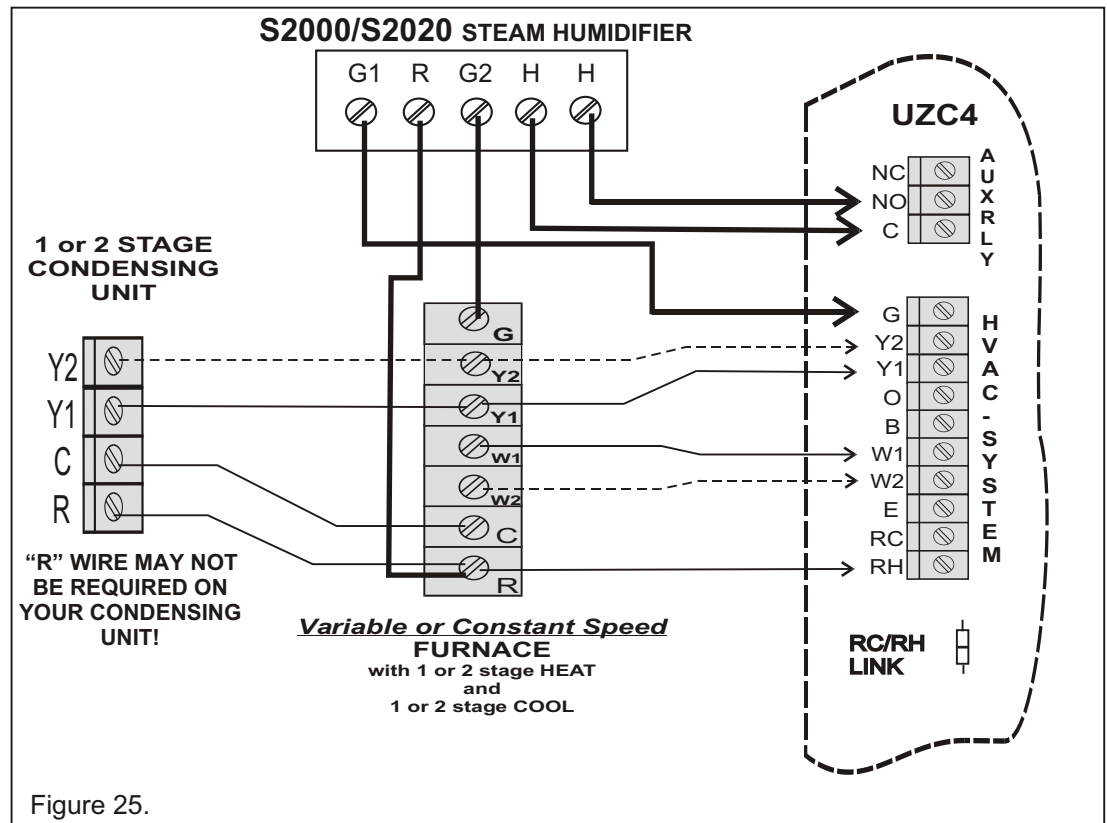

Figure 25.

Wiring for typical 2 stage Heat, 2 stage cool conventional HVAC System. Diagram reflects Humidification terminal wired to the Auxiliary output (NO) Normally Open terminal. Auxiliary Relay Dip Switch #5, Bank #2, should be set to Direct Acting. (DA)

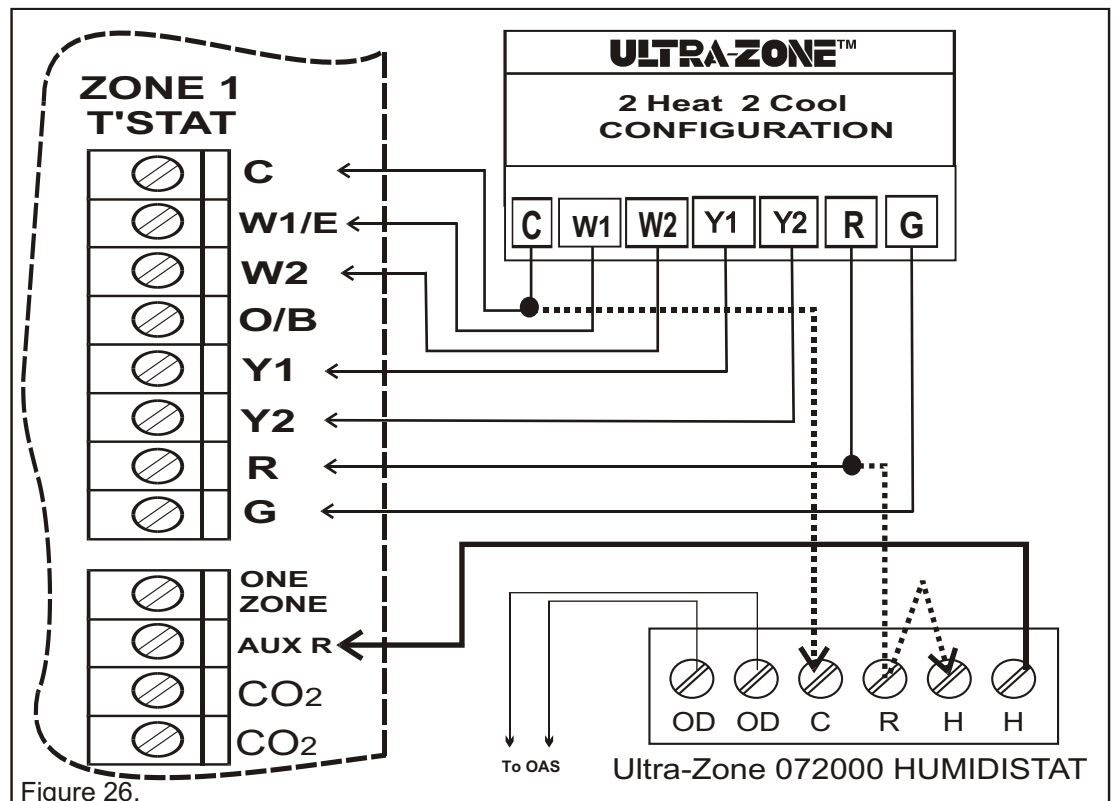

Figure 26.

Wiring for typical 2 stage Heat, 2 stage cool Conventional HVAC System. Diagram reflects a Direct Acting Humidification control wired to the Auxiliary input. Auxiliary Relay Dip Switch #5, Bank #2, should be set to Direct Acting. (DA) Refer to the Ultra-Zone 072000 Tech. Bulletin.

SYSTEM WIRING CONTINUED - Specialty Applications

The UZC4 features a CO₂ Monitoring interlock system that will activate a Fresh Air Damper and the indoor Fan on the HVAC system in response to a Separate CO₂ Monitor. This powerful feature allows **Demand Based Ventilation** of a large home or commercial building, based on the daily occupancy levels. **Demand Based Ventilation saves energy, reduces over-ventilation, and optimizes air quality in the building.**

Wire up the UZC4 to a separate CO₂ Monitor with auxiliary dry contacts as shown. Also install and wire up a fresh air damper as shown.

Set the PPM trip threshold on the CO₂ Monitor per the Mfr's. Instructions or local requirements.

Upon activation, the UZC4 will open the Fresh Air Damper and Start the Indoor Fan if it is not already running. The UZC4 will continue the ventilation process, until the CO₂ Monitor resets. Other devices can be connected to the CO₂ terminals such as a Clock Timer, Manual Switch or Enthalpy Control.

NOTE: Cooling & Heating operations are not affected by activation of this feature.

NOTE: Activation of the Fire Alarm Interlock Feature will over-ride (shutdown) the fresh air ventilation process.

Using the UZC4's CO₂ Feature to satisfy Building Fresh Air Ventilation Codes

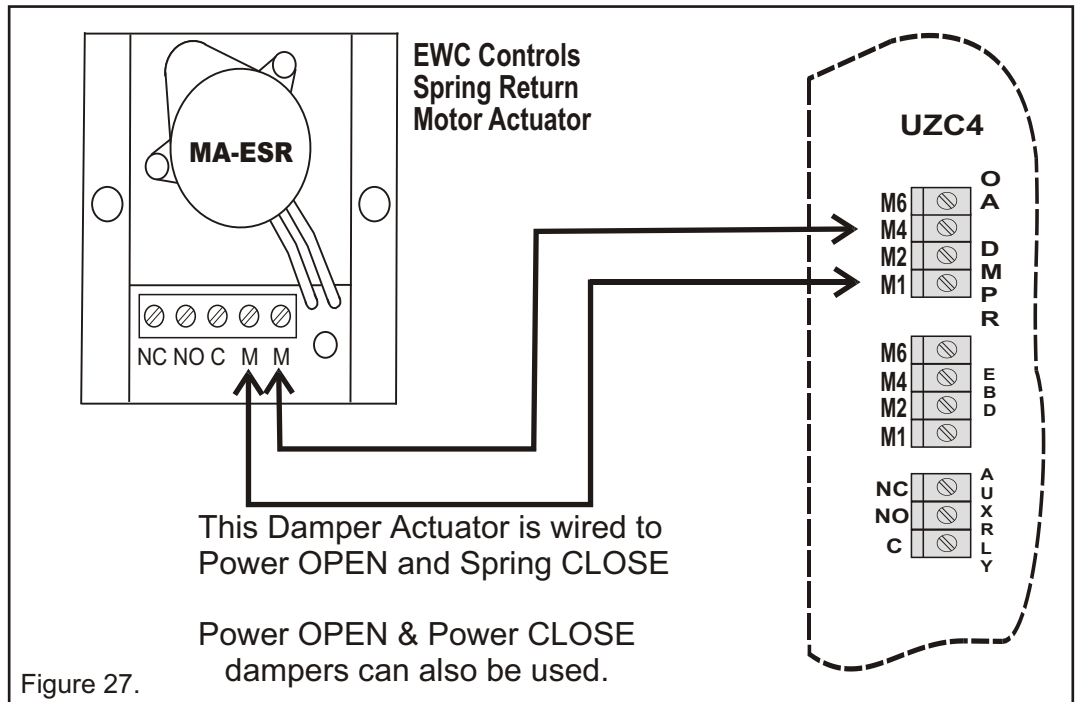

Figure 27.

This diagram reflects the UZC4 OA DMPR Output terminals wired to an UltraZone Spring Closed type damper. When the UZC4 detects a Ventilation Demand, it will energize the damper open and force the Indoor Fan to run. The UZC4 will stay in this mode until the CO₂ Monitor detects an acceptable CO₂ level in the building.

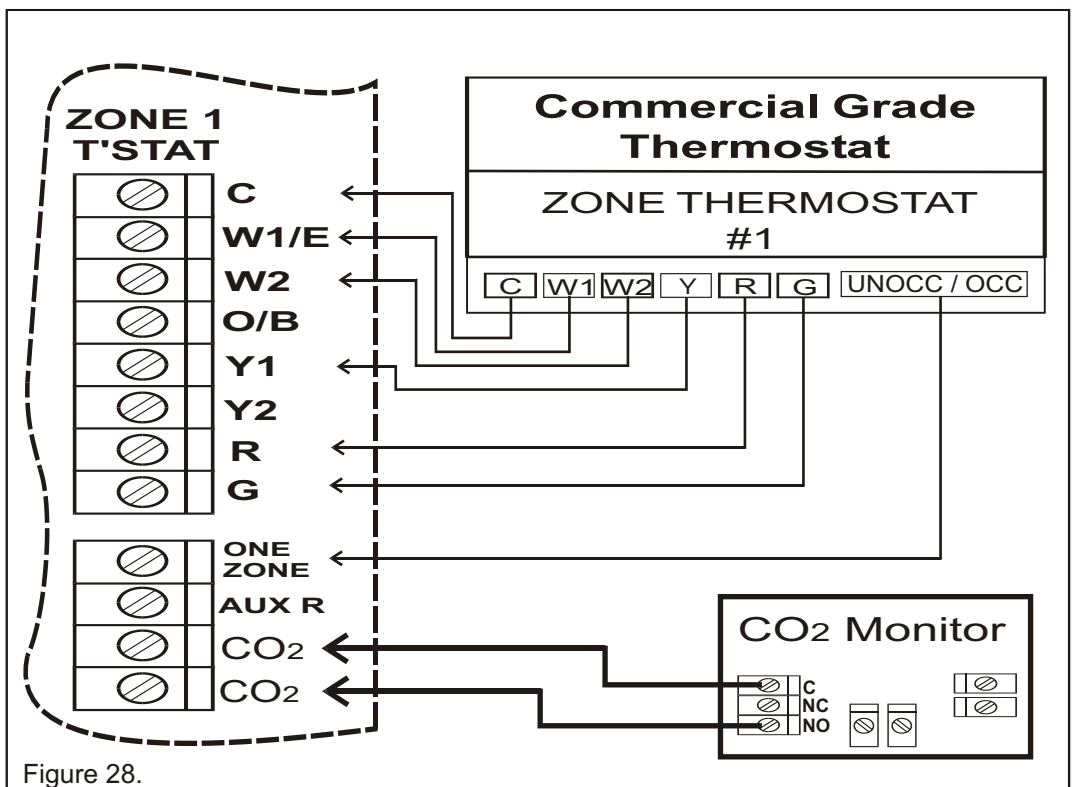

Figure 28.

This diagram reflects the UZC4 CO₂ terminals wired to the (NO) normally open contacts of a third party device. The circuit is normally open and the contacts must close to activate this feature. This feature operates regardless of all other functions except the FIRE Mode interlock.

SYSTEM WIRING CONTINUED - Specialty Applications

The UZC4 has a "FIRE" interlock feature that allows the UZC4 to satisfy HVAC Fire Code in Residential & Commercial buildings. Coordinate with the Fire Systems Contractor to interlock the UZC4 into the building Fire Alarm system as shown and cut the Jumper 1. When properly interlocked to the buildings Fire Alarm system, the UZC4 becomes an integral part of the Fire Safety System. If the Fire Alarm system activates, the UZC4 will shutdown the controlled HVAC system and force all connected dampers to the closed positions, effectively isolating the duct work and the Fan system. This action will reduce the spread of smoke advancing through the building assisted by Fan and Duct systems that are not interlocked with a Fire Alarm system, or equipped with the capability to do so.

This action will reduce the spread of smoke advancing through the building assisted by Fan and Duct systems that are not interlocked with a Fire Alarm system, or equipped with the capability to do so.

Using the UZC4's "FIRE Interlock" Feature to satisfy Building Fire Codes

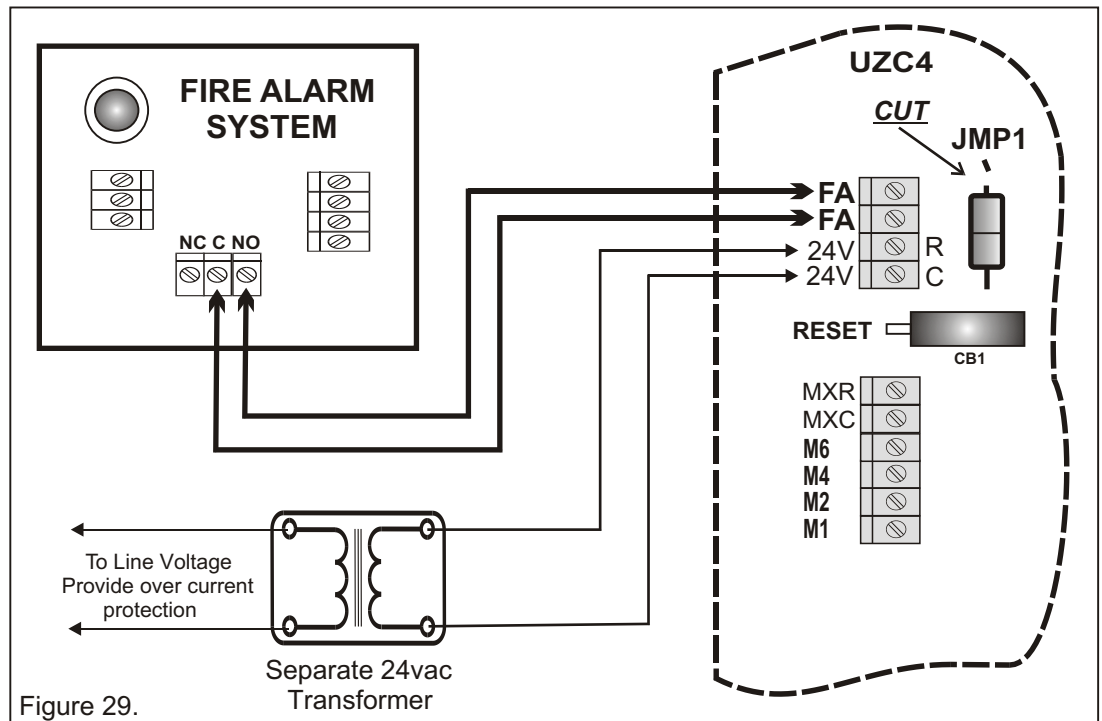

Figure 29.

This diagram reflects the UZC4 Fire Alarm Output terminals wired to a FIRE ALARM System with a Fail Safe, Normally Open Dry Contact. The circuit is normally closed and must OPEN to activate the UZC4 FIRE MODE. Be sure to cut the Jumper 1 resistor when you interlock the UZC4 to the Fire Alarm System. When the UZC4 activates Fire Mode, the HVAC System will shutdown and all connected dampers will close to Isolate & Compartmentalize the HVAC Duct System. The Fire Alarm System must reset to NORMAL before the UZC4 will allow HVAC Operations to resume.

The UZC4 has a set of dedicated terminals to power up and control an (EBD) Electronic Bypass Damper. The UZC4 will assume control of the EBD and force it to the OPEN position during the Idle periods, Short cycle delays or Changeover delays. It will also maintain that open position for 45 seconds at the start of any thermostat demand for Heating, Cooling, or Fan only operation. After 45 seconds the UZC4 will release control of the EBD, resulting in a smooth gradual increase in static pressure. The 45 second startup delay allows a Constant speed fan to start in a "Quiet Mode" eliminating air noise upon system startup. It also eliminates hunting on variable speed systems and it enhances the latent cooling capacity of any HVAC system.

Using the UZC4's "ON BOARD BYPASS DAMPER SUPPORT"

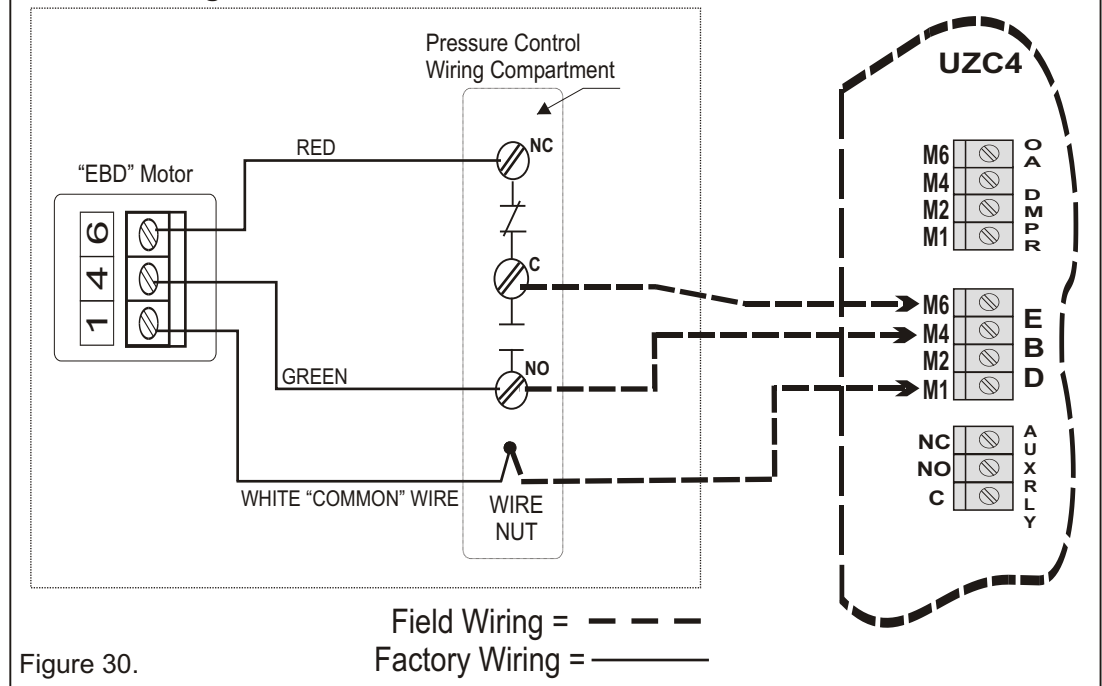

Figure 30.

Wire up the "EBD" straight to the UZC4 to obtain integrated Bypass Damper operational support via the UZC4's bypass firmware. The UZC4 defaults the bypass damper open during idle periods and releases control to the EBD 45 seconds after the Fan starts. This action results in a smooth, quiet startup and gradual increase in static pressure.

DAMPER WIRING AND CONFIGURATION

Note: All zone dampers default to the "OPEN" position after a purge delay has occurred. Dampers also default "OPEN" during changeover & short cycle delays, and when all zone demands are satisfied, and no signals are detected from the thermostats.

REFERENCE THESE DIAGRAMS PRIOR TO INSTALLATION AND POWER WIRING. DOING SO WILL SAVE TIME AND LABOR ON THE JOB SITE.

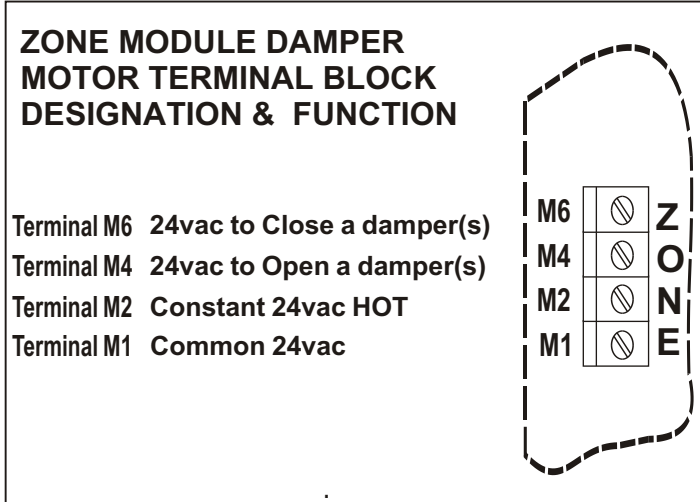

Figure 31.

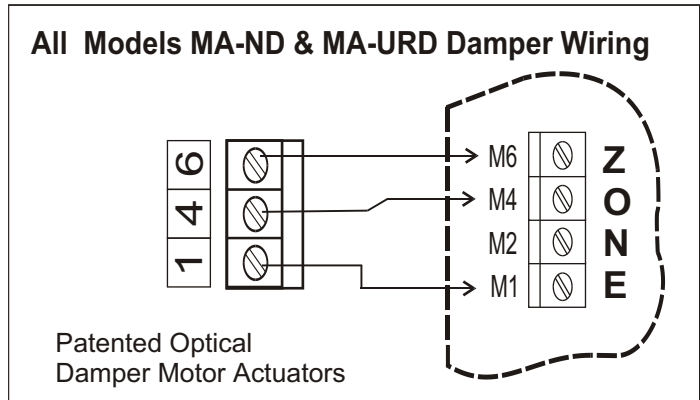

Figure 32.

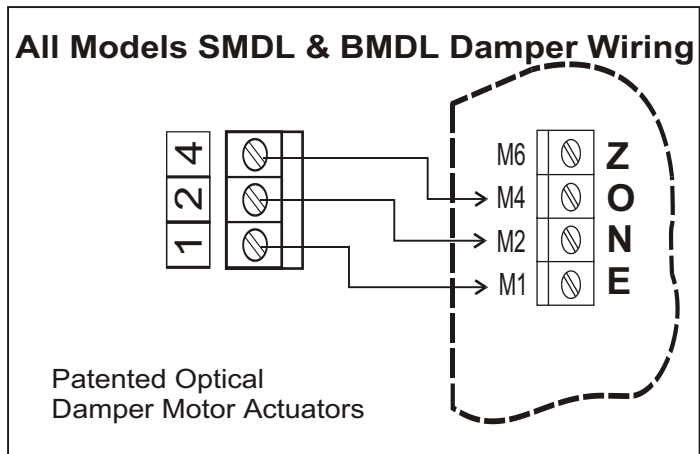

Figure 33.

2 Wire Spring Return Motor Wiring

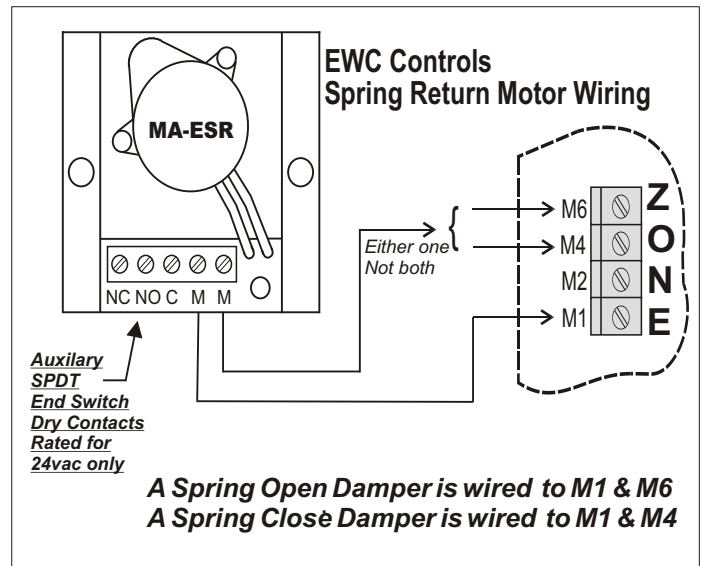

Figure 34.

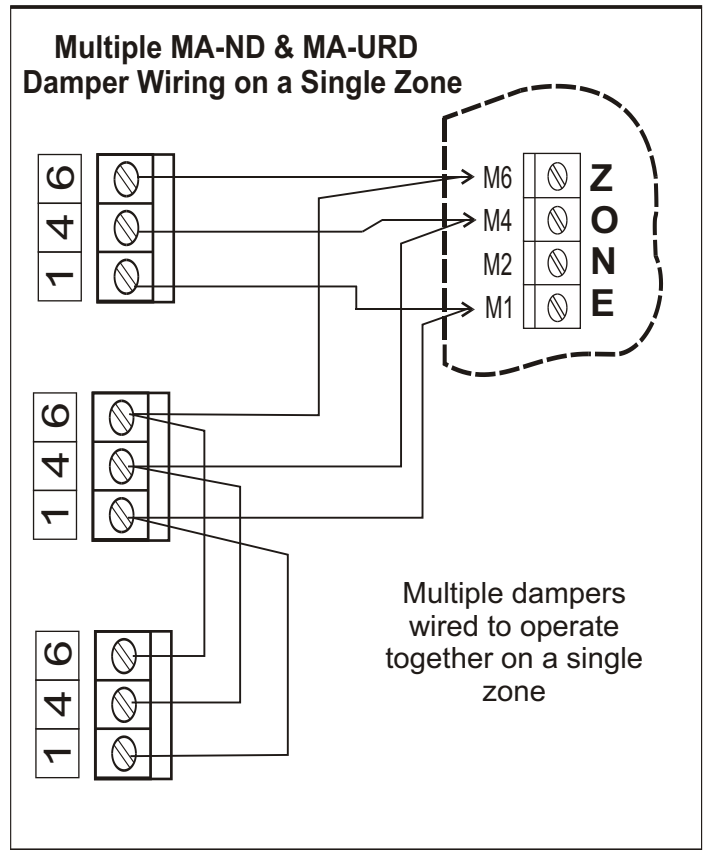
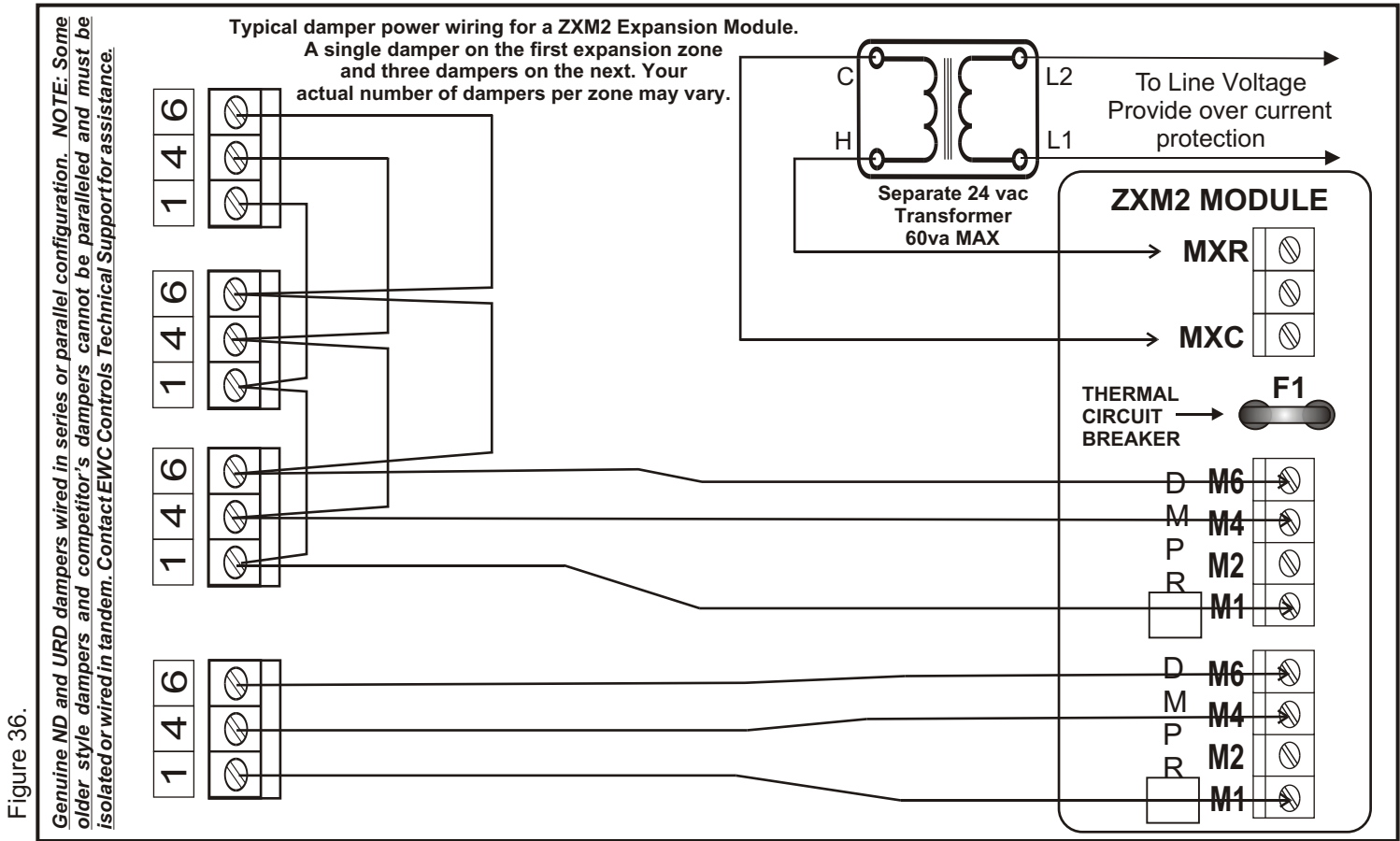

Figure 35.

On all these dampers and most older style dampers, including competitor's dampers, always wire up number to number. Contact EWC Controls Technical Support when you are on the job site for assistance with damper wiring.
NOTE: Some older style dampers cannot be wired in parallel. Do not overload your transformer!

DAMPER WIRING, DAMPER TESTING AND POWER SUPPLY SOLUTIONS

Unlike previous models, the UZC4 series allows “**Damper Motor Power Isolation**” on the Main and Expansion modules. The Main Module’s motor blocks can be isolated only if necessary, but the Expansion module motor blocks must be powered by a separate transformer. This advanced design provides automatic 2.5amp over-current protection for each Expansion module motor block and allows a maximum 60va transformer to be connected. This means that you can directly connect a theoretical maximum of 12 Genuine ND/URD dampers to a single 2 zone expansion module. Now you no longer have to isolate & power up multiple dampers using field installed relays. The Expansion modules provide the isolation for you. See the diagram below for typical wiring solutions for dampers.



UZC4 Recommended Power Solutions

Number of Zones	ND / URD's/SID's @ 1.5 va per damper W/MA-ND5						Use class 2 UL Listed 1585 inherently current limiting transformers only!	Spring Types @ 8 - 10 va per damper					
	1-4 Zones		1-4 Zones		1-4 Zones			1-4 Zones		1-4 Zones		1-4 Zones	
	4	10	6	12	8	14		4	10	6	12	8	14
4	40va	10	50va	16	75va		4	40va	10	60va	16	75va	
6	40va	12	50va	18	75va		6	50va	12	60va	18	100va	
8	40va	14	60va	20	75va		8	50va	14	75va	20	100va	

Non-inherently current limiting transformers must have field provided over-current protection on the secondary 24 vac output. The table values provided pertain to genuine ULTRAZONE Dampers and Competitors typical 24 vac Spring loaded dampers. Included in these VA load ratings are the correct number of thermostats, the UZC4 Zone System, and a 5% field factor. Spring loaded dampers draw higher currents & require more power.

TESTING DAMPER MOTORS

- ND / URD / SMD / BMD Dampers** - Connect 24vac common to terminal 1 and 24vac hot to terminal 4. Damper should Open. Remove 24vac hot from terminal 4 and apply to terminal 6. Damper should Close
 - SR /SRE Power Close / Spring Open Dampers** - Connect 24vac common & hot to the two motor (M) terminals. Damper should Close. Remove 24 vac hot. Damper should Open.
 - SR /SRE Power Open / Spring Close Dampers** - Connect 24vac common & hot to the two motor (M) terminals. Damper should Open. Remove 24vac hot. Damper should Close.
- SERVICE NOTE:** Additional power for adding dampers to the main UZC4 module, is accomplished by cutting the “J2” jumper and powering MXR & MXC with a separate 24vac 40va power transformer. These terminals are not to be used to power up expansion modules.

UZC4 LED FUNCTION AND DESCRIPTION

UZC4 LED's

The **UZC4** is equipped with 18 LED's which indicate system operation and status. Familiarize yourself with the LED's definitions, in order to quickly determine the system status and mode of operation.

- GREEN POWER** The **POWER** LED pulses as a steady heart beat to indicate proper Microprocessor operation.
- RED OAS** The **OAS LIMIT** LED illuminates solid to indicate that the Outdoor Temperature has fallen below the chosen set point. LED will blink rapidly to indicate a malfunctioning Outdoor Air Sensor.
- RED SAS** The **SAS LIMIT** LED illuminates solid to indicate that the Supply Temperature has exceeded the chosen set point on either the HIGH TEMP LIMIT or the LOW TEMP LIMIT. LED will blink rapidly to indicate a malfunctioning Supply Air Sensor.
- RED RAS** The **RAS LIMIT** LED illuminates solid to indicate that the Return Temperature has exceeded the chosen set point. LED will blink rapidly to indicate a malfunctioning Return Air Sensor.
- GREEN ZONE 4 OPEN** **ZONE 4** LED will illuminate solid to indicate that damper(s) is energized open, and the Zone is active.
- GREEN ZONE 3 OPEN** **ZONE 3** LED will illuminate solid to indicate that damper(s) is energized open, and the Zone is active.
- GREEN ZONE 2 OPEN** **ZONE 2** LED will illuminate solid to indicate that damper(s) is energized open, and the Zone is active.
- GREEN ZONE 1 OPEN** **ZONE 1** LED will illuminate solid to indicate that damper(s) is energized open, and the Zone is active.
- GREEN OA DMPR OPEN** The **OA DMPR OPEN** LED will illuminate solid to indicate that the Outside Air damper is energized open in response to the CO₂ detector or other device to provide demand based ventilation.
- GREEN BYPASS DMPR** The **BYPASS DMPR** LED will illuminate solid to indicate that the Bypass damper(s) is being forced to the Open position. Occurs during idle, short cycle and changeover periods.
- ORANGE AUX RELAY** The **AUX RELAY** LED will illuminate solid to indicate that the Auxiliary relay is being energized in response to a demand, to start a function such as Humidify or De-humidify.
- GREEN FAN** The **FAN** LED will illuminate solid to indicate a demand for fan operation, during COOLING, HEATING, PURGE, or CONTINUOUS FAN operations.
- YELLOW COMPRESSOR 2** The **COMPRESSOR 2** LED illuminates solid to indicate the 2nd stage compressor is energized.
- YELLOW COMPRESSOR 1** The **COMPRESSOR 1** LED illuminates solid to indicate the 1st stage compressor is energized.
- ORANGE REV VALVE 'O'** The **REV VALVE 'O'** LED will illuminate solid to indicate that the reversing valve on a heat pump system is being energized to the COOL position. The LED will be **out** during heating mode on a heat pump.
- RED W1 HEAT** The **W1** LED illuminates solid to indicate 1st stage of HEATING is energized in a conventional HVAC system. Or the **W1** LED illuminates solid to indicate the 1st stage of Auxiliary or Backup heat is energized in a heat pump system. (3rd stage heat) Also illuminates during Emergency mode.
- RED W2 HEAT** The **W2** LED illuminates solid to indicate 2nd stage of HEATING is energized in a conventional HVAC system. Or the **W2** LED illuminates solid to indicate the 2nd stage of Auxiliary or Backup heat is energized in a heat pump system. (4th stage heat) Also illuminates during Emergency mode.
- RED EMERGENCY** The **EMERGENCY** LED illuminates solid to indicate all stages of Auxiliary, Backup, and Standby Heat have been energized and Compressor 1 and 2 have been locked out. This is done in response to a demand from any Heat Pump thermostat connected to any zone. It can also be activated via the On-board Emergency switch. When Emergency mode is activated, the W1 & W2 LED's will also illuminate.
- RED GROUND FAULT** The **GROUND FAULT** LED illuminates when the Circuit Breaker Trips due to an electrical short in the thermostat field wiring or possibly in the main module damper field wiring. The electrical short must be located and repaired before the circuit breaker can be reset to normal.

ZXM2 FEATURES AT A GLANCE

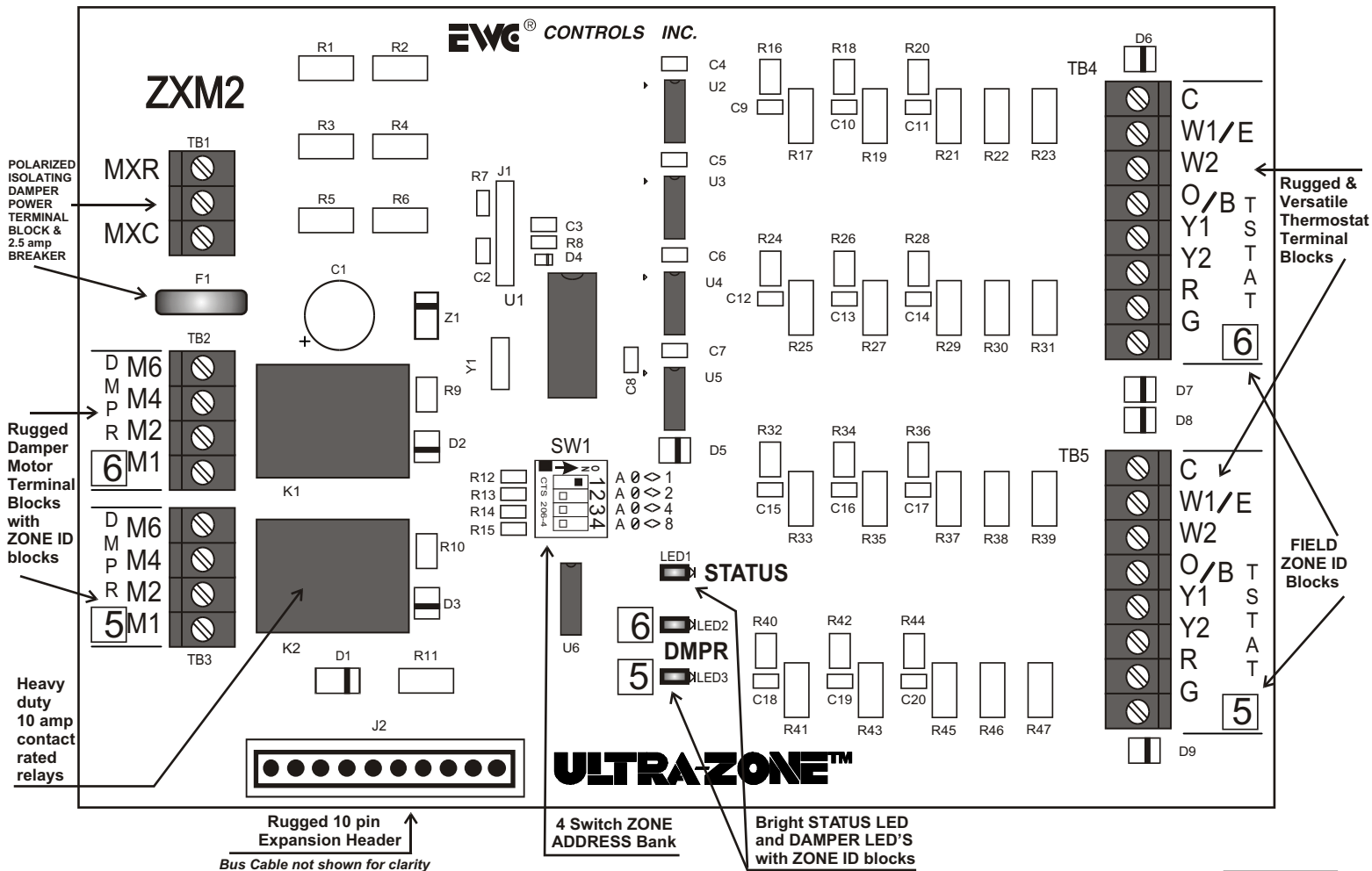

The ZXM2 Expansion Module for the UZC4 series is pictured above. A total of nine (9) ZXM2's can be connected to the UZC4 to create a 22 ZONE system! The modules are housed and linked together via a factory supplied 10 conductor BUS CABLE and a unique Expansion Header Card. The UZC4 expands by connecting factory assembled Expansion Systems such as the ZXM2A, ZXM4A and ZXM6A that are pre-wired and configured for you at the factory. The UZC4 connects to these housed expansion assemblies via a flexible 20" long bus cable. Each Expansion module has a set of address switches that must be set properly to allow the UZC4 to recognize each expansion module in the correct order. Note the "STATUS" LED provided on every Expansion Module to indicate active micro-processor operation. There are also two "DAMPER" LED's provided to indicate which damper(s) are energized open or closed. Next to each Damper and Thermostat terminal block is a blank white square, where the "Zone Number" can be written to easily identify it as a new expanded zone. These blocks will be filled in for you at the factory when a UZC 6 zone, 8 zone, 10 zone or higher has been ordered. The ZXM2 address switches will also be factory set for you. Note the same multi-input thermostat terminals are supplied on the ZXM2 as are supplied on the UZC4 Main Module. Most Important of all is to note the MXR & MXC Damper Motor Power Input Block. The ZXM2 Expansion Module is powered via the Bus Cable from the UZC4, but the power for the dampers must be provided by a separate transformer and is isolated from the module. This allows great freedom to connect as many dampers as the 2.5 amp thermal breaker can handle. See page 19 for damper motor power supply details. Make sure to read the ZXM2 Technical Bulletin for the proper cabling scenarios and zone address settings for your system or refer to the chart on the right.

All Expansion module Dip switch banks must be set correctly for proper zone address identification. The 1st expansion module would be zones 5 & 6. The 2nd expansion module would be zones 7 & 8. The 3rd expansion module would be zones 9 & 10. And so on up the line for a total of 22 zones.

The switches are set for you at the factory unless you are expanding the system in the field. It is a good idea to check them anyway.

Expansion Panel No.	Dip Switch Settings
9	
8	
7	
6	
5	
4	
3	
2	
1	

T R O U B L E S H O O T I N G

SYMPTOM	SOLUTIONS
LED'S are responding properly but HVAC system is malfunctioning.	Check HVAC system wiring for proper connections. Check HVAC system wiring for shorts/miswiring. Check HVAC System. Check HVAC System technical documentation and Mfr's Technical Support.
LED's are not responding properly and HVAC system is malfunctioning.	Check HVAC system wiring for shorts/miswiring. Check HVAC system wiring for proper connections. Check HVAC thermostat for proper connections. Refer to Technical Bulletin for correct Setup/Wiring/Dip Switch settings.
LED's illuminate and HVAC system functions normally but dampers do not respond.	Check damper motor wiring for proper connections. Check damper motor 24vac transformer voltage/fuse/UZC4 circuit breaker. Check damper motor wiring for shorts/miswiring. Refer to Technical Bulletin for correct Setup/Wiring.
REFER TO THE DAMPER MOTOR TESTING PAGE 8	
LED's do not illuminate and HVAC system does not respond.	Check HVAC/UZC4 system transformer supply voltage. Check HVAC/UZC4 system 24vac transformer voltage/fuse/UZC4 circuit breaker. Check the Fire Alarm system. The UZC4 will not operate if the fire alarm is active and the interlock is used. 24vac can be read across an open FA circuit.

CHECK YOUR WIRING

DETECTING 24vac SHORTS	SYMPTOMS: Modules, Motors or both will not function
HVAC system not responding and UZC4 LED's are Off.	If 24vac short has occurred, 24vac will be present at the <i>UZC4 Module Input terminals R & C</i> ; but 24vac will not be present at the <i>Thermostat R&C</i> terminals. The Ground Fault LED is illuminated!
Dampers not responding and THE UZC4 LED's are Off or On.	SOLUTIONS: Remove 24vac power from UZC4 and reset the manual circuit breaker or allow the thermal breaker to cool off. Find and repair short(s) in damper and/or thermostat field wiring. Restore 24 vac power.
ISOLATING 24vac SHORTS <i>F1 circuit breaker protects the UZC4 and all connected modules. Reacts to a short in the damper motor or thermostat component and field wiring.</i>	Disconnect the wire(s) from the ' <i>R</i> ' terminals on the <i>UZC4 thermostat terminal blocks</i> , and the " <i>M2/M4/M6</i> " terminals on the UZC4 damper motor terminal blocks. Restore power. If the short is no longer present, Ohm out the thermostat and damper field wiring for shorts/misconnections. Replace or repair wires as necessary. Restore power. Module(s) will resume operation.

TESTING CONVENTIONAL THERMOSTATS

During a demand for heating, the thermostat should apply a 24vac hot signal to the W1 and or W2 terminals.

During a demand for cooling, the thermostat should apply a 24vac hot signal to the Y1, Y2 and G terminals.

During a continuous fan demand, the thermostat should apply a 24vac hot signal to the G terminal.

Check to make sure that the thermostat Rc and Rh terminals are connected together, unless your application requires separation of these circuits.

Use the (C) Common terminal provided at each thermostat terminal block to wire up full 24 vac hard-wired thermostats.

You should reference the (C) Common terminal when troubleshooting incoming thermostat demand signals, even if no wire is connected there.

TECHNICAL SUPPORT

EWC Controls provides superior toll free Troubleshooting Support for the UZC4 when you are on the job site!

Call 1-800-446-3110 Monday - Friday 8am to 5pm East Coast Time.

Otherwise call 1-732-446-3110 for information on the UZC4 and other ULTRA-ZONE products.

When calling for Technical Support, please have a multi-meter, pocket screwdriver, and wire cutter/stripper handy.