

**HEAT PUMP
HIGH EFFICIENCY 16 SEER
1-1/2 THRU 5 TONS SPLIT SYSTEM
ENVIRONMENTALLY BALANCED
R-410A REFRIGERANT
208 / 230 Volt, 1-phase, 60 Hz**

EcoTemp

WCH64**



This product has been designed and manufactured to meet ENERGY STAR criteria for energy efficiency when matched with appropriate coil components. However, proper refrigerant charge and proper air flow are critical to achieve rated capacity and efficiency. Installation of this product should follow the manufacturer's refrigerant charging and air flow instructions. Failure to confirm proper charge and airflow may reduce energy efficiency and shorten equipment life.



Use of the AHRI Certified TM Mark indicates a manufacturer's participation in the program. For verification of certification for individual products, go to www.ahridirectory.org.

Model Number	Size (tons)	Nominal Btu/hr	Min. Circuit Ampacity	Max. Fuse or Breaker	Operating Dimensions height x width x depth in. (mm)	Ship / Operating Weight lbs. (kg)
WCH6184GKB	1-1/2	18,000	13.6	20	35-1/16 x 31-3/16 x 31-3/16 (891 x 793 x 793)	199 / 167 (90 / 76)
WCH6244GKB	2	24,000	15.5	25	32-1/16 x 35 x 35 (815 x 889 x 889)	189 / 172 (86 / 78)
WCH6304GKB	2-1/2	30,000	19.9	30	32-1/16 x 35 x 35 (815 x 889 x 889)	228 / 207 (103 / 94)
WCH6364GKB	3	36,000	21.6	35	32-1/16 x 35 x 35 (815 x 889 x 889)	237 / 215 (108 / 98)
WCH6424GKB	3-1/2	42,000	27.8	40	32-1/16 x 35 x 35 (815 x 889 x 889)	256 / 233 (116 / 106)
WCH6484GKB	4	48,000	31.8	45	32-1/16 x 35 x 35 (815 x 889 x 889)	262 / 238 (119 / 108)
WCH6604GKB	5	60,000	33.9	50	45-11/16 x 35 x 35 (1161 x 889 x 889)	317 / 288 (144 / 130)

**ALL MODELS
REFRIGERATION CIRCUIT**

- Scroll compressors on all models
- Suction line accumulator factory installed
- Bi-flow filter-drier included for field installation
- Integrated solid state control with Time-Temperature Defrost
- High and Low pressure switches
- Copper tube / aluminum fin coil

EASY TO INSTALL AND SERVICE

- Easy Access service valves on all models
- External high and low refrigerant service ports
- Only two screws to access control panel
- Factory charged with R-410A refrigerant

BUILT TO LAST

- Pre-painted cabinet finish over galvanized steel
- Coated inlet grille with 3/8" (10mm) grille spacing for extra protection

LIMITED WARRANTY*

- 1 year unit replacement limited warranty
- 5 year parts limited warranty (including compressor and coil)
 - With timely registration, an additional 5 years parts limited warranty (including compressor and coil)

* For residential applications only. See warranty certificate for complete details and restrictions, including warranty coverage for other applications.

Product Specifications

OUTDOOR UNIT MODEL NUMBER IDENTIFICATION GUIDE									
Digit Position:	1,2	3	4	5,6	7	8	9	10	11
Example Part Number:	WC	H	6	24	4	G	K	B	3
WC = Condensing Unit									
A = Air Conditioner									
H = Heat Pump									
TYPE									
4 = 14 SEER									
5 = 15 SEER									
6 = 16 SEER									
SEER									
18 = 18,000 BTUH = 1-1/2 tons									
24 = 24,000 BTUH = 2 tons									
30 = 30,000 BTUH = 2-1/2 tons									
36 = 36,000 BTUH = 3 tons									
42 = 42,000 BTUH = 3-1/2 tons									
48 = 48,000 BTUH = 4 tons									
60 = 60,000 BTUH = 5 tons									
NOMINAL CAPACITY									
4 = R-410A									
REFRIGERANT									
A = Standard Grille									
G = Coil Guard Grille									
FEATURE									
K = 208/230-1-60									
VOLTAGE									
Sales Code									
Extra Digit									

ACCESSORIES PART NUMBER IDENTIFICATION GUIDE									
Digit Position:	1	2	3	4	5	6, 7	8, 9	10, 11	
Example Part Number:	N	A	S	A	0	01	01	CH	
N = Non-Branded									
BRANDING									
A = Accessory									
PRODUCT GROUP									
S = Split System (AC & HP)									
KIT USAGE									
A = Original									
B = 2nd Generation									
MAJOR SERIES									
0 = Generic or Not Applicable									
4 = R-410A									
REFRIGERANT									
Product Identifier Number									
Package Quantity									
Type of Kit (Example: CH = Crankcase Heater)									

UNIT	SERIES	ELECTRICAL CHARACTERISTICS		A		B		C		D		E		F		G		H		I		J		K		OPERATING WEIGHT		SHIPPING WEIGHT		SHIPPING LENGTH / WIDTH (Sq.)		SHIPPING HEIGHT																
		INCH	MM	INCH	MM	INCH	MM	INCH	MM	INCH	MM	INCH	MM	INCH	MM	INCH	MM	INCH	MM	INCH	MM	INCH	MM	INCH	MM	Lbs	Kgs	Lbs	Kgs	INCH	MM	INCH	MM	INCH	MM													
WCH6184GKB300	3	Y	N	N	31	3/16	792.5	35	1/16	890.7	5/8	15.9	6	9/16	166.1	24	11/16	626.3	9	1/8	231.3	1	1/8	28.2	3	13/16	97.4	15	3/4	400.1	16	406.4	16	1/4	412.8	167	75.7	199	90.3	32	3/16	817.9	36	11/16	891.3	33	3/4	857.6
WCH6244GKB300	3	Y	N	N	35	889.0	32	1/16	815.1	5/8	15.9	6	9/16	166.1	28	7/16	722.8	9	1/8	231.3	1	1/8	28.2	3	13/16	97.4	17	1/2	444.5	17	7/8	454.0	15	5/8	396.9	172	78.0	189	85.7	36	9/14.9	33	3/4	857.6				
WCH6304GKB300	3	Y	N	N	35	889.0	32	1/16	815.1	3/4	19.1	6	9/16	166.1	28	7/16	722.8	9	1/8	231.3	1	1/8	28.2	3	13/16	97.4	17	1/4	438.2	16	7/8	428.6	15	3/4	400.1	207	93.9	228	103.4	36	9/14.9	33	3/4	857.6				
WCH6364GKB300	3	Y	N	N	35	889.0	32	1/16	815.1	3/4	19.1	6	9/16	166.1	28	7/16	722.8	9	1/8	231.3	1	1/8	28.2	3	13/16	97.4	17	3/8	441.3	17	1/2	444.5	13	3/4	348.3	215	97.5	237	107.5	36	9/14.9	33	3/4	857.6				
WCH6424GKB300	3	Y	N	N	35	889.0	32	1/16	815.1	7/8	22.2	6	9/16	166.1	28	7/16	722.8	9	1/8	231.3	1	1/8	28.2	3	13/16	97.4	16	1/4	412.8	17	7/8	454.0	15	7/8	403.2	233	105.7	256	116.1	36	9/14.9	33	3/4	857.6				
WCH6484GKB300	3	Y	N	N	35	889.0	32	1/16	815.1	7/8	22.2	6	9/16	166.1	28	7/16	722.8	9	1/8	231.3	1	1/8	28.2	3	13/16	97.4	16	1/8	409.6	18	457.2	14	7/8	377.8	238	108.0	262	118.8	36	9/14.9	33	3/4	857.6					
WCH6604GKB300	3	Y	N	N	35	889.0	45	11/16	1160.5	7/8	22.2	6	9/16	166.1	28	7/16	722.8	9	1/8	231.3	1	1/8	28.2	3	13/16	97.4	17	7/8	454.0	16	1/4	412.8	19	482.6	288	130.6	317	143.8	36	9/14.9	47	3/8	1203.2					

Y= YES
N= NO

NOTES:
1. CENTER OF GRAVITY

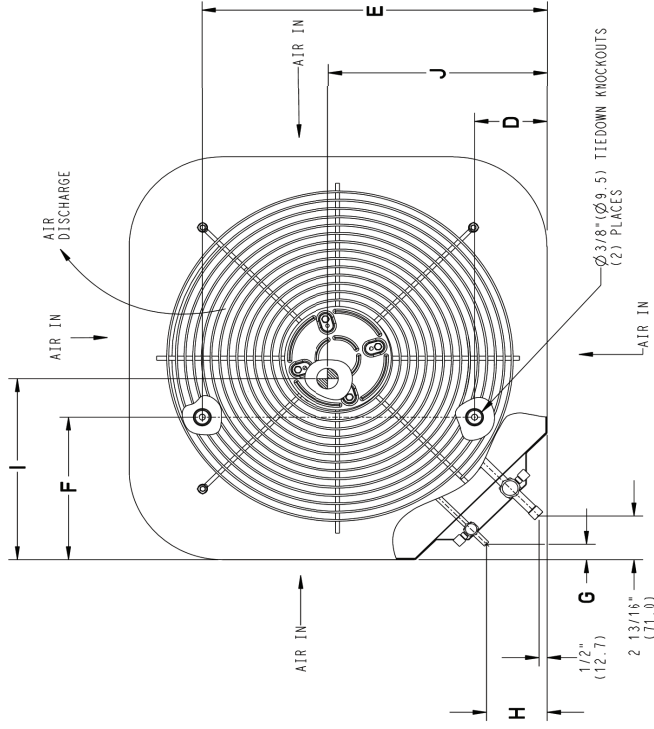
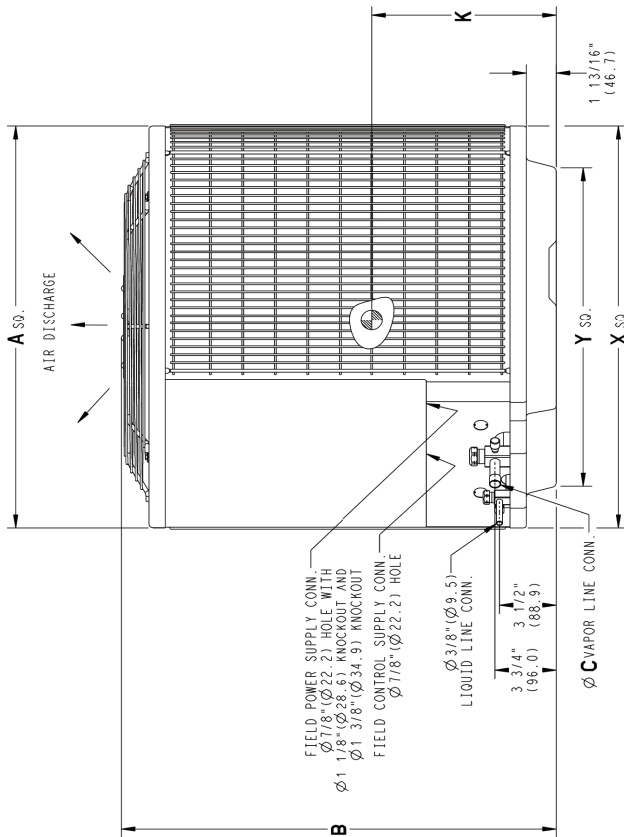

UNIT SIZE	"X"	"Y"	"Z"	
23 1/8	587.3	17 7/8	454.6	
25 3/4	654.0	20 7/16	518.5	
18	31 3/16	792.5	583.2	
24-30-36-42-48-60	35	889.0	26 3/4	679.7

NOTE: ALL DIMENSIONS IN INCH (MM)

U.S. ECCN: Not Subject to Regulation (N.S.R.)

Copy of SDS490-1 REV. A

PHYSICAL DATA							
Model Size	18	24	30	36	42	48	60
Nominal Cooling Capacity (BTU/hr)	18,000	24,000	30,000	36,000	42,000	48,000	60,000
Nominal SEER	16.0	16.0	16.0	16.0	16.0	16.0	16.0
Sound Rating (dBA)**	68	72	72	72	68	73	70
PSC Fan Motor HP	1/12	1/12	1/12	1/12	1/3	1/4	1/3
Fan RPM (single speed)	810	810	810	810	700	810	767
Fan CFM	2233	3223	3223	3223	3770	4046	4400
Coil Face Area ft ² (m ²)	19.30 (1.40)	20.10 (1.87)	20.10 (1.87)	20.10 (1.87)	20.10 (1.87)	20.10 (1.87)	35.47 (3.29)
Coil Rows-fins per inch	1 - 20	1 - 20	2 - 20	2 - 20	2 - 20	2 - 20	2 - 20
Low Pressure Switch Open Pressure (psig) Close Pressure (psig)	23 ± 5 55 ± 5	23 ± 5 55 ± 5	23 ± 5 55 ± 5	23 ± 5 55 ± 5	23 ± 5 55 ± 5	23 ± 5 55 ± 5	23 ± 5 55 ± 5
High Pressure Switch Open Pressure (psig) Close Pressure (psig)	670 ± 10 470 ± 25	670 ± 10 470 ± 25	670 ± 10 470 ± 25	670 ± 10 470 ± 25	670 ± 10 470 ± 25	670 ± 10 470 ± 25	670 ± 10 470 ± 25
Liquid Line Connection Size in. (mm)	3/8 (10)	3/8 (10)	3/8 (10)	3/8 (10)	3/8 (10)	3/8 (10)	3/8 (10)
Vapor Line Connection Size in. (mm)	5/8 (16)	5/8 (16)	3/4 (19)	3/4 (19)	7/8 (22)	7/8 (22)	7/8 (22)
Recommended Line Set Liquid Tube Diameter in. (mm)	3/8 (10)	3/8 (10)	3/8 (10)	3/8 (10)	3/8 (10)	3/8 (10)	3/8 (10)
Recommended Line Set Vapor Tube Diameter in. (mm)	5/8 (16) *	5/8 (16) *	3/4 (19) *	3/4 (19) *	7/8 (22) *	7/8 (22) *	1-1/8 (28.6)*
* Units are rated with 25 ft (7.6 m) of lineset length. See R-410A Cooling Capacity Loss for Various Line Lengths & Tube Diameters table when using other sizes and lengths of lineset. Note: See unit Installation Instructions for proper installation.							
Factory Charge R-410A lbs. (kg)	7.00 (3.18)	7.60 (3.45)	9.75 (4.42)	11.20 (5.08)	9.92 (4.50)	9.87 (4.48)	13.00 (5.90)
Required Subcooling °F (°C)	8 (4.4)	7 (3.9)	7 (3.9)	10 (5.6)	9 (5.0)	9 (5.0)	7 (3.9)

ELECTRICAL DATA (208/230-1-60, voltage range 197V - 253V)							
Model Size	18	24	30	36	42	48	60
Minimum Circuit Ampacity - MCA (amps)	13.6	15.5	19.9	21.6	27.8	31.8	33.9
Maximum OverCurrent Protective device - MOCP (amps)	20	25	30	35	40	45	50
Compressor RLA (Rated Load Amps) LRA (Locked Rotor Amps)	10.5 56.3	11.9 62.9	15.4 72.5	16.8 75.0	20.0 123.9	24.4 130.0	24.9 152.5
Fan Motor FLA (Full Load Amps)	0.5	0.6	0.6	0.6	2.8	1.3	2.8

** Sound Rating for 24 and 30 sizes tested in accordance with AHRI Standard 270-2008 (not listed with AHRI). All other sizes tested in accordance with AHRI Standard 270-1995 (not listed with AHRI).

R-410A COOLING CAPACITY LOSS FOR VARIOUS LINE LENGTHS & TUBE DIAMETERS

Unit Nominal Size (Btuh)	Maximum Liquid Line Diameters (In. OD)	Acceptable Vapor Line Diameters (In. OD)	Cooling Capacity Loss (%) Total Equivalent Line Length (ft)										
			Standard Application				Long Line Application Requiries Accessories						
			25 (7.62)	50 (15.2)	80 (24.4)	80+ (24.4+)	100 (30.48)	125 (38.10)	150 (45.72)	175 (53.34)	200 (60.96)	225 (68.58)	250 (76.20)
18000 1-Stage HP	3/8	1/2	1	2	3	3	4	6	7	8	9	10	12
		5/8	0	0	1	1	1	1	2	2	3	3	3
24000 1-Stage HP	3/8	5/8	0	1	1	1	2	3	3	4	4	5	6
		3/4	0	0	0	0	0	1	1	1	1	1	2
30000 1-Stage HP	3/8	5/8	1	2	3	3	3	4	5	6	7	8	9
		3/4	0	0	1	1	1	1	2	2	2	3	3
		7/8	0	0	0	0	0	1	1	1	1	1	1
36000 1-Stage HP	3/8	5/8	1	2	4	4	5	6	7	9	10	11	13
		3/4	0	0	1	1	1	2	2	3	3	4	4
		7/8	0	0	0	0	0	1	1	1	1	2	2
42000 1-Stage HP	3/8	3/4	0	1	2	2	2	3	4	4	5	6	6
		7/8	0	0	1	1	1	1	2	2	2	3	3
48000 1-Stage HP	3/8	3/4	0	1	2	2	3	4	5	5	6	7	8
		7/8	0	0	1	1	1	2	2	2	3	3	4
60000 1-Stage HP	3/8	3/4	1	2	4	4	5	6	7	9	10	11	12
		7/8	0	1	2	2	2	3	4	4	5	5	6
		1 1/8	0	0	0	0	1	1	1	1	1	1	2

Standard Length = 80 feet (24.4m) or less total equivalent length

Applications in this area are long line. Accessories are required as shown recommended on the Long Line Application Guidelines.

Applications in this area may have height restrictions that limit allowable total equivalent length when outdoor unit is below indoor unit. See Long Line Application Guidelines.

DETAILED COOLING CAPACITIES#

EVAPORATOR AIR		CONDENSER ENTERING AIR TEMPERATURES ° F (° C)																							
		75 (23.9)				85 (29.4)				95 (35)				105 (40.6)				115 (46.1)				125 (51.7)			
		CFM	EWB ° F (° C)	Capacity MBtuh		Total System KW**	Capacity MBtuh		Total System KW**	Capacity MBtuh		Total System KW**	Capacity MBtuh		Total System KW**	Capacity MBtuh		Total System KW**	Capacity MBtuh		Total System KW**				
Total	Sens†			Total	Sens†		Total	Sens†		Total	Sens†		Total	Sens†		Total	Sens†		Total	Sens†					
WCH6184GKB* Outdoor Section With WAXL184A* Indoor Section																									
545	72 (22.2)	21.64	11.38	0.99	20.62	10.99	1.17	19.56	10.60	1.37	18.43	10.19	1.60	17.23	9.75	1.87	15.94	9.29	2.19						
	67 (19.4)	19.65	13.99	1.00	18.73	13.61	1.18	17.76	13.21	1.38	16.74	12.79	1.61	15.65	12.35	1.88	14.49	11.89	2.20						
	63 (17.2)††	18.21	13.45	1.01	17.36	13.07	1.18	16.46	12.67	1.39	15.51	12.26	1.62	14.50	11.81	1.89	13.42	11.35	2.21						
	62 (16.7)	17.90	16.53	1.01	17.08	16.13	1.18	16.22	15.71	1.39	15.34	15.19	1.62	14.47	14.47	1.89	13.59	13.59	2.21						
	57 (13.9)	17.36	17.36	1.01	16.70	16.70	1.19	16.01	16.01	1.39	15.26	15.26	1.62	14.45	14.45	1.89	13.57	13.57	2.21						
600	72 (22.2)	21.94	11.80	0.99	20.90	11.42	1.17	19.80	11.02	1.38	18.65	10.60	1.61	17.41	10.16	1.88	16.09	9.69	2.20						
	67 (19.4)	19.95	14.67	1.00	19.00	14.28	1.18	18.00	13.87	1.38	16.95	13.45	1.62	15.83	13.00	1.89	14.64	12.53	2.21						
	63 (17.2)††	18.50	14.08	1.01	17.62	13.69	1.19	16.70	13.29	1.39	15.72	12.87	1.63	14.69	12.42	1.90	13.58	11.94	2.22						
	62 (16.7)	18.24	17.42	1.01	17.40	16.99	1.19	16.56	16.43	1.39	15.72	15.72	1.62	14.87	14.87	1.90	13.95	13.95	2.21						
	57 (13.9)	17.92	17.92	1.01	17.22	17.22	1.19	16.49	16.49	1.39	15.70	15.70	1.63	14.85	14.85	1.90	13.93	13.93	2.21						
675	72 (22.2)	22.28	12.35	1.00	21.21	11.97	1.18	20.07	11.56	1.38	18.88	11.14	1.62	17.60	10.69	1.89	16.26	10.22	2.21						
	67 (19.4)	20.28	15.56	1.01	19.30	15.16	1.19	18.26	14.74	1.39	17.18	14.31	1.63	16.04	13.85	1.90	14.82	13.36	2.22						
	63 (17.2)††	18.83	14.91	1.02	17.91	14.51	1.20	16.96	14.10	1.40	15.96	13.67	1.64	14.88	13.20	1.91	13.76	12.71	2.23						
	62 (16.7)	18.66	18.49	1.02	17.85	17.85	1.20	17.08	17.08	1.40	16.24	16.24	1.63	15.34	15.34	1.90	14.36	14.36	2.22						
	57 (13.9)	18.57	18.57	1.02	17.83	17.83	1.20	17.05	17.05	1.40	16.22	16.22	1.63	15.32	15.32	1.90	14.35	14.35	2.22						

EVAPORATOR AIR		CONDENSER ENTERING AIR TEMPERATURES ° F (° C)																							
		75 (23.9)				85 (29.4)				95 (35)				105 (40.6)				115 (46.1)				125 (51.7)			
		CFM	EWB ° F (° C)	Capacity MBtuh		Total System KW**	Capacity MBtuh		Total System KW**	Capacity MBtuh		Total System KW**	Capacity MBtuh		Total System KW**	Capacity MBtuh		Total System KW**	Capacity MBtuh		Total System KW**				
Total	Sens†			Total	Sens†		Total	Sens†		Total	Sens†		Total	Sens†		Total	Sens†		Total	Sens†					
WCH6244GKB* Outdoor Section With WAXL244A* Indoor Section																									
700	72 (22.2)	28.14	14.70	1.30	26.53	14.04	1.51	24.88	13.37	1.74	23.19	12.70	2.02	21.40	12.00	2.34	19.51	11.26	2.70						
	67 (19.4)	25.57	18.15	1.31	24.12	17.45	1.52	22.62	16.74	1.75	21.06	16.02	2.03	19.44	15.27	2.35	17.73	14.49	2.72						
	63 (17.2)††	23.72	17.45	1.32	22.36	16.76	1.53	20.97	16.06	1.76	19.54	15.34	2.04	18.02	14.60	2.35	16.46	13.84	2.72						
	62 (16.7)	23.33	21.49	1.32	22.02	20.72	1.53	20.70	19.92	1.76	19.48	18.74	2.04	18.07	18.07	2.35	16.74	16.74	2.72						
	57 (13.9)	22.69	22.69	1.33	21.60	21.60	1.53	20.47	20.47	1.76	19.29	19.29	2.04	18.04	18.04	2.35	16.72	16.72	2.72						
800	72 (22.2)	28.65	15.44	1.32	26.99	14.77	1.52	25.29	14.09	1.76	23.52	13.39	2.03	21.68	12.68	2.35	19.74	11.94	2.72						
	67 (19.4)	26.07	19.36	1.33	24.55	18.63	1.53	23.00	17.90	1.77	21.39	17.14	2.04	19.72	16.37	2.36	17.98	15.55	2.73						
	63 (17.2)††	24.19	18.57	1.34	22.79	17.86	1.54	21.35	17.13	1.78	19.85	16.38	2.05	18.31	15.61	2.37	16.69	14.81	2.74						
	62 (16.7)	23.91	23.02	1.34	22.58	22.36	1.54	21.30	21.30	1.78	20.04	20.04	2.05	18.71	18.71	2.37	17.30	17.30	2.74						
	57 (13.9)	23.64	23.64	1.34	22.47	22.47	1.54	21.27	21.27	1.78	20.01	20.01	2.05	18.69	18.69	2.37	17.28	17.28	2.74						
900	72 (22.2)	29.05	16.16	1.33	27.34	15.47	1.54	25.58	14.77	1.77	23.77	14.06	2.05	21.88	13.33	2.37	19.90	12.58	2.74						
	67 (19.4)	26.44	20.51	1.34	24.88	19.76	1.55	23.28	18.99	1.79	21.65	18.21	2.06	19.94	17.40	2.38	18.16	16.54	2.75						
	63 (17.2)††	24.56	19.64	1.35	23.12	18.90	1.56	21.63	18.14	1.79	20.10	17.36	2.07	18.53	16.56	2.39	16.89	15.71	2.76						
	62 (16.7)	24.64	23.75	1.35	23.23	23.23	1.56	21.96	21.96	1.79	20.63	20.63	2.07	19.24	19.24	2.38	17.76	17.76	2.75						
	57 (13.9)	24.42	24.42	1.35	23.20	23.20	1.56	21.93	21.93	1.79	20.61	20.61	2.07	19.21	19.21	2.38	17.74	17.74	2.75						

See note on pg. 9

DETAILED COOLING CAPACITIES# CONTINUED

EVAPORATOR AIR		CONDENSER ENTERING AIR TEMPERATURES ° F (° C)																	
CFM	EWB ° F (° C)	75 (23.9)			85 (29.4)			95 (35)			105 (40.6)			115 (46.1)			125 (51.7)		
		Capacity MBtuh	Sens†	Total System KW**	Capacity MBtuh	Sens†	Total System KW**	Capacity MBtuh	Sens†	Total System KW**	Capacity MBtuh	Sens†	Total System KW**	Capacity MBtuh	Sens†	Total System KW**	Capacity MBtuh	Sens†	Total System KW**
	72 (22.2)	34.74	18.39	1.78	33.09	17.76	1.98	31.33	17.09	2.20	29.42	16.38	2.45	27.35	15.63	2.74	25.12	14.82	3.08
	67 (19.4)	31.56	22.65	1.78	30.07	22.02	1.98	28.48	21.35	2.20	26.78	20.65	2.46	24.93	19.90	2.75	22.94	19.09	3.08
875	63 (17.2)††	29.27	21.78	1.78	27.99	21.15	1.98	26.43	20.49	2.21	24.87	19.80	2.46	23.18	19.06	2.75	21.36	18.26	3.08
	62 (16.7)	28.78	26.78	1.78	27.46	26.13	1.98	26.07	25.42	2.21	24.61	24.42	2.46	23.19	23.19	2.75	21.67	21.67	3.08
	57 (13.9)	27.94	27.94	1.78	26.87	26.87	1.98	25.74	25.74	2.21	24.51	24.51	2.46	23.15	23.15	2.75	21.64	21.64	3.08
	72 (22.2)	35.24	19.11	1.82	33.54	18.47	2.02	31.70	17.79	2.24	29.73	17.07	2.49	27.59	16.30	2.78	25.29	15.48	3.11
	67 (19.4)	32.04	23.83	1.82	30.49	23.19	2.02	28.85	22.51	2.24	27.08	21.79	2.49	25.18	21.02	2.78	23.13	20.18	3.11
975	63 (17.2)††	29.72	22.87	1.82	28.30	22.24	2.02	26.78	21.56	2.24	25.17	20.85	2.49	23.44	20.09	2.78	21.56	19.27	3.11
	62 (16.7)	29.32	28.34	1.82	27.97	27.61	2.02	26.69	26.47	2.24	25.26	25.26	2.49	23.81	23.81	2.78	22.21	22.21	3.11
	57 (13.9)	28.87	28.87	1.82	27.74	27.74	2.02	26.53	26.53	2.24	25.23	25.23	2.49	23.78	23.78	2.78	22.18	22.18	3.11
	72 (22.2)	35.72	19.87	1.83	33.95	19.23	2.02	32.06	18.54	2.24	30.04	17.81	2.50	27.84	17.03	2.79	25.49	16.20	3.12
	67 (19.4)	32.48	25.03	1.83	30.89	24.39	2.02	29.20	23.70	2.25	27.34	22.93	2.50	25.45	22.16	2.79	23.35	21.30	3.12
1075	63 (17.2)††	30.16	24.00	1.83	28.69	23.35	2.02	27.13	22.66	2.25	25.48	21.94	2.50	23.70	21.15	2.79	21.79	20.29	3.12
	62 (16.7)	29.89	29.78	1.83	28.59	28.59	2.02	27.33	27.32	2.25	25.93	25.93	2.50	24.41	24.41	2.79	22.73	22.73	3.12
	57 (13.9)	29.73	29.73	1.83	28.55	28.55	2.02	27.28	27.28	2.25	25.90	25.90	2.50	24.39	24.39	2.79	22.71	22.71	3.12

EVAPORATOR AIR		CONDENSER ENTERING AIR TEMPERATURES ° F (° C)																	
CFM	EWB ° F (° C)	75 (23.9)			85 (29.4)			95 (35)			105 (40.6)			115 (46.1)			125 (51.7)		
		Capacity MBtuh	Sens†	Total System KW**	Capacity MBtuh	Sens†	Total System KW**	Capacity MBtuh	Sens†	Total System KW**	Capacity MBtuh	Sens†	Total System KW**	Capacity MBtuh	Sens†	Total System KW**	Capacity MBtuh	Sens†	Total System KW**
	72 (22.2)	42.58	22.75	2.17	40.39	21.89	2.43	38.17	21.02	2.70	35.86	20.13	2.99	33.42	19.21	3.33	30.80	18.24	3.73
	67 (19.4)	38.21	27.66	2.13	36.25	26.81	2.39	34.27	25.96	2.66	32.22	25.09	2.95	30.04	24.18	3.29	27.71	23.21	3.69
1050	63 (17.2)††	35.13	26.47	2.10	33.34	25.64	2.36	31.53	24.81	2.63	29.66	23.95	2.92	27.68	23.06	3.27	25.63	22.14	3.67
	62 (16.7)	34.44	32.48	2.09	32.73	31.63	2.35	31.00	30.75	2.62	29.26	29.80	2.92	27.57	27.57	3.27	25.85	25.85	3.67
	57 (13.9)	33.22	33.22	2.08	31.88	31.88	2.35	30.52	30.52	2.62	29.08	29.08	2.92	27.53	27.53	3.26	25.81	25.81	3.67
	72 (22.2)	43.63	23.99	2.21	41.32	23.10	2.47	38.97	22.21	2.74	36.54	21.29	3.03	33.99	20.35	3.37	31.26	19.35	3.77
	67 (19.4)	39.14	29.58	2.16	37.08	28.70	2.42	35.00	27.83	2.69	32.84	26.93	2.99	30.58	25.99	3.33	29.01	22.44	3.73
1200	63 (17.2)††	36.00	28.25	2.13	34.11	27.40	2.39	32.21	26.54	2.66	30.25	25.66	2.96	28.18	24.73	3.30	25.96	23.74	3.70
	62 (16.7)	35.41	34.99	2.13	33.64	34.03	2.39	31.94	31.94	2.66	30.38	30.38	2.96	28.69	28.69	3.30	26.84	26.84	3.71
	57 (13.9)	34.81	34.81	2.12	33.36	33.36	2.39	31.88	31.88	2.66	30.33	30.33	2.96	28.66	28.66	3.30	26.81	26.81	3.71
	72 (22.2)	44.45	25.15	2.25	42.03	24.25	2.51	39.59	23.34	2.78	37.06	22.41	3.07	34.41	21.44	3.41	31.59	20.43	3.80
	67 (19.4)	39.88	31.41	2.20	37.73	30.52	2.46	35.56	29.61	2.73	33.34	28.69	3.02	30.98	27.71	3.36	28.50	26.67	3.76
1350	63 (17.2)††	36.68	29.96	2.17	34.71	29.07	2.43	32.75	28.19	2.70	30.72	27.28	2.99	28.58	26.32	3.33	26.31	25.28	3.74
	62 (16.7)	36.31	36.11	2.17	34.67	34.67	2.43	33.09	33.09	2.70	31.42	31.42	3.00	29.63	29.63	3.34	27.67	27.67	3.75
	57 (13.9)	36.17	36.17	2.16	34.61	34.61	2.43	33.04	33.04	2.70	31.38	31.38	3.00	29.59	29.59	3.34	27.64	27.64	3.75

See note on pg. 9

DETAILED COOLING CAPACITIES# CONTINUED

EVAPORATOR AIR		CONDENSER ENTERING AIR TEMPERATURES ° F (° C)																							
		75 (23.9)				85 (29.4)				95 (35)				105 (40.6)				115 (46.1)				125 (51.7)			
		CFM	EWB ° F (° C)	Capacity MBtuh		Total System KW**	Capacity MBtuh		Total System KW**	Capacity MBtuh		Total System KW**	Capacity MBtuh		Total System KW**	Capacity MBtuh		Total System KW**	Capacity MBtuh		Total System KW**				
Total	Sens†			Total	Sens†		Total	Sens†		Total	Sens†		Total	Sens†		Total	Sens†		Total	Sens†					
WCH6424GKB* Outdoor Section With WAXL424A* Indoor Section																									
	72 (22.2)	49.04	25.60	2.46	46.75	24.73	2.77	44.33	23.81	3.13	41.74	22.85	3.54	38.94	21.83	4.01	35.94	20.75	4.53						
	67 (19.4)	44.71	31.50	2.45	42.65	30.64	2.76	40.50	29.74	3.12	38.18	28.78	3.52	35.65	27.75	3.99	32.94	26.66	4.52						
1240	63 (17.2)††	41.58	30.36	2.44	39.68	29.50	2.75	37.68	28.61	3.10	35.55	27.66	3.51	33.23	26.64	3.98	30.72	25.55	4.51						
	62 (16.7)	40.84	37.24	2.43	39.03	36.36	2.75	37.11	35.41	3.10	35.08	34.36	3.51	32.97	32.97	3.98	30.91	30.91	4.52						
	57 (13.9)	39.45	39.45	2.43	38.01	38.01	2.74	36.47	36.47	3.10	34.78	34.78	3.51	32.92	32.92	3.98	30.87	30.87	4.52						
	72 (22.2)	49.88	26.77	2.49	47.51	25.88	2.80	44.97	24.95	3.16	42.28	23.97	3.57	39.38	22.93	4.03	36.29	21.83	4.56						
	67 (19.4)	45.53	33.39	2.48	43.38	32.50	2.79	41.14	31.59	3.15	38.72	30.60	3.55	36.12	29.55	4.02	33.32	28.42	4.55						
1400	63 (17.2)††	42.37	32.12	2.46	40.40	31.24	2.78	38.32	30.33	3.13	36.09	29.35	3.54	33.70	28.31	4.01	31.11	27.18	4.54						
	62 (16.7)	41.74	39.72	2.46	39.86	38.75	2.78	37.93	37.64	3.13	36.02	36.02	3.54	34.04	34.04	4.01	31.85	31.85	4.55						
	57 (13.9)	40.98	40.98	2.46	39.43	39.43	2.77	37.77	37.77	3.13	35.97	35.97	3.54	33.99	33.99	4.01	31.82	31.82	4.55						
	72 (22.2)	50.60	27.99	2.52	48.12	27.08	2.84	45.50	26.14	3.19	42.72	25.15	3.60	39.73	24.09	4.07	36.58	22.99	4.59						
	67 (19.4)	46.20	35.36	2.51	44.00	34.46	2.82	41.65	33.51	3.18	39.18	32.51	3.59	36.50	31.42	4.05	33.64	30.25	4.59						
1575	63 (17.2)††	43.05	33.97	2.49	41.00	33.06	2.81	38.85	32.12	3.17	36.57	31.12	3.57	34.10	30.04	4.04	31.46	28.86	4.58						
	62 (16.7)	42.62	42.11	2.49	40.79	40.79	2.81	39.03	39.03	3.17	37.11	37.11	3.58	35.00	35.00	4.05	32.69	32.69	4.58						
	57 (13.9)	42.38	42.38	2.49	40.73	40.73	2.81	38.98	38.98	3.17	37.06	37.06	3.58	34.96	34.96	4.05	32.66	32.66	4.58						

EVAPORATOR AIR		CONDENSER ENTERING AIR TEMPERATURES ° F (° C)																							
		75 (23.9)				85 (29.4)				95 (35)				105 (40.6)				115 (46.1)				125 (51.7)			
		CFM	EWB ° F (° C)	Capacity MBtuh		Total System KW**	Capacity MBtuh		Total System KW**	Capacity MBtuh		Total System KW**	Capacity MBtuh		Total System KW**	Capacity MBtuh		Total System KW**	Capacity MBtuh		Total System KW**				
Total	Sens†			Total	Sens†		Total	Sens†		Total	Sens†		Total	Sens†		Total	Sens†		Total	Sens†					
WCH6484GKB* Outdoor Section With WAXL484A* Indoor Section																									
	72 (22.2)	58.07	30.35	2.80	55.36	29.34	3.22	52.51	28.30	3.71	49.43	27.18	4.27	46.11	25.98	4.93	42.57	24.73	5.67						
	67 (19.4)	53.00	37.44	2.79	50.57	36.44	3.21	48.00	35.41	3.69	45.23	34.30	4.26	42.21	33.10	4.91	38.97	31.82	5.65						
1420	63 (17.2)††	49.29	36.08	2.78	47.05	35.09	3.19	44.69	34.07	3.68	42.13	32.96	4.24	39.35	31.77	4.89	36.34	30.48	5.64						
	62 (16.7)	48.39	44.32	2.78	46.26	43.32	3.19	43.97	42.23	3.68	41.55	41.01	4.24	39.34	38.63	4.89	36.61	36.61	5.64						
	57 (13.9)	46.84	46.84	2.77	45.13	45.13	3.19	43.29	43.29	3.67	41.27	41.27	4.24	39.04	39.04	4.89	36.56	36.56	5.64						
	72 (22.2)	59.07	31.73	2.83	56.23	30.71	3.25	53.24	29.63	3.74	50.06	28.50	4.31	46.62	27.29	4.96	42.99	26.03	5.70						
	67 (19.4)	53.94	39.66	2.82	51.41	38.64	3.24	48.73	37.59	3.73	45.85	36.46	4.29	42.74	35.23	4.95	39.40	33.92	5.69						
1600	63 (17.2)††	50.21	38.16	2.81	47.88	37.15	3.23	45.42	36.10	3.72	42.77	34.97	4.28	39.90	33.75	4.93	36.79	32.42	5.68						
	62 (16.7)	49.44	47.26	2.81	47.22	46.15	3.23	45.37	43.72	3.72	42.73	42.73	4.28	40.34	40.34	4.93	37.71	37.71	5.68						
	57 (13.9)	48.62	48.62	2.81	46.78	46.78	3.23	44.83	44.83	3.71	42.67	42.67	4.28	40.29	40.29	4.93	37.66	37.66	5.68						
	72 (22.2)	59.90	33.20	2.87	56.96	32.15	3.29	53.86	31.07	3.78	50.55	29.91	4.35	47.05	28.70	5.00	43.33	27.42	5.74						
	67 (19.4)	54.77	42.05	2.85	52.13	41.01	3.28	49.35	39.92	3.77	46.39	38.76	4.33	43.18	37.50	4.99	39.78	36.14	5.73						
1800	63 (17.2)††	51.02	40.37	2.85	48.60	39.34	3.26	46.06	38.27	3.75	43.32	37.11	4.32	40.36	35.85	4.97	37.19	34.48	5.72						
	62 (16.7)	50.90	49.06	2.85	48.40	48.40	3.26	46.31	46.31	3.75	44.01	44.01	4.32	41.48	41.48	4.98	38.71	38.71	5.73						
	57 (13.9)	50.29	50.29	2.84	48.34	48.34	3.26	46.25	46.25	3.75	43.96	43.96	4.32	41.43	41.43	4.98	38.67	38.67	5.73						

See note on pg. 9

DETAILED COOLING CAPACITIES# CONTINUED

EVAPORATOR AIR		CONDENSER ENTERING AIR TEMPERATURES ° F (° C)																	
CFM	EWB ° F (° C)	75 (23.9)			85 (29.4)			95 (35)			105 (40.6)			115 (46.1)			125 (51.7)		
		Capacity MBtuh	Total System KW**	Sens†	Capacity MBtuh	Total System KW**	Sens†	Capacity MBtuh	Total System KW**	Sens†	Capacity MBtuh	Total System KW**	Sens†	Capacity MBtuh	Total System KW**	Sens†	Capacity MBtuh	Total System KW**	Sens†
		WCH6604GKB* Outdoor Section With WAXL604A* Indoor Section																	
	72 (22.2)	67.41	34.75	3.24	63.92	33.45	3.71	60.21	32.09	4.25	56.21	30.64	4.87	51.85	29.08	5.58	47.29	27.48	6.39
	67 (19.4)	61.41	42.78	3.23	58.31	41.51	3.69	55.00	40.18	4.23	51.44	38.76	4.85	47.09	37.03	5.55	43.40	35.59	6.38
	63 (17.2)††	57.06	41.22	3.21	54.24	39.98	3.68	51.22	38.66	4.22	47.58	37.09	4.83	44.36	35.73	5.55	40.59	34.13	6.37
	62 (16.7)	56.01	50.59	3.21	53.30	49.32	3.68	50.38	47.94	4.22	47.07	46.25	4.83	44.15	44.15	5.55	41.01	41.01	6.38
	57 (13.9)	54.03	54.03	3.20	51.89	51.89	3.67	49.54	49.54	4.21	46.96	46.96	4.84	44.10	44.10	5.55	40.97	40.97	6.38
	72 (22.2)	68.27	35.89	3.27	64.69	34.58	3.74	60.82	33.17	4.28	56.74	31.73	4.90	52.25	30.15	5.61	47.62	28.54	6.43
	67 (19.4)	62.25	44.63	3.26	59.04	43.34	3.73	55.63	41.99	4.27	51.94	40.54	4.89	47.24	38.68	5.59	43.73	37.32	6.42
	63 (17.2)††	57.89	42.95	3.25	54.95	41.68	3.72	51.83	40.35	4.25	48.43	38.90	4.88	44.79	37.36	5.59	40.91	35.72	6.41
	62 (16.7)	56.91	53.05	3.24	54.11	51.71	3.71	51.17	50.18	4.25	48.17	48.17	4.88	45.13	45.13	5.59	41.87	41.87	6.42
	57 (13.9)	55.57	55.57	3.24	53.30	53.30	3.71	50.83	50.83	4.25	48.05	48.05	4.87	45.10	45.10	5.59	41.82	41.82	6.42
	72 (22.2)	69.42	37.71	3.33	65.65	36.37	3.80	61.66	34.96	4.34	57.41	33.51	4.96	52.76	31.87	5.68	48.01	30.25	6.49
	67 (19.4)	63.34	47.60	3.32	59.99	46.28	3.79	56.42	44.88	4.33	52.60	43.39	4.95	48.44	41.76	5.66	44.15	40.05	6.49
	63 (17.2)††	58.94	45.70	3.30	55.88	44.41	3.77	52.62	43.03	4.31	49.13	41.55	4.94	45.33	39.94	5.65	41.36	38.22	6.48
	62 (16.7)	58.21	56.77	3.30	55.41	55.41	3.77	52.72	52.72	4.32	49.80	49.80	4.94	46.54	46.54	5.66	43.04	43.04	6.48
	57 (13.9)	57.76	57.76	3.30	55.32	55.32	3.77	52.66	52.66	4.32	49.72	49.72	4.94	46.48	46.48	5.66	43.00	43.00	6.48

* Tested combination.

† The kW values include the compressor, outdoor fan motor, and indoor blower motor. The kW from supplement heaters should be added to these values to obtain total system kilowatts.

‡ Sensible capacities shown are based on 80°F (27°C) entering air at the indoor coil. For sensible capacities at other than 80°F (27°C), deduct 835 Btuh (245 kW) per 1000 CFM (480 L/S) of indoor coil air for each degree below 80°F (27°C), or add 835 Btuh (245 kW) per 1000 CFM (480 L/S) of indoor coil air per degree above 80°F (27°C).

Detailed cooling capacities are based on indoor and outdoor unit at the same elevation per AHRI standard 210/240-2008. If additional tubing length and/or indoor unit is located above outdoor unit, a slight variation in capacity may occur.

** System kW is total of indoor and outdoor unit kilowatts.

†† At TVA rating indoor condition (75°F edb/63°F ewb). All other indoor air temperatures are at 80°F edb.

EWB — Entering Wet Bulb

NOTE: When the required data fall between the published data, interpolation may be performed. Extrapolation is not an acceptable practice.

Accessory Description and Usage (Listed Alphabetically)

1. Ball-Bearing Fan Motor

A fan motor with ball bearings which permits speed reduction while maintaining bearing lubrication.

2. Compressor Start Assist - Capacitor and Relay

Start capacitor and relay gives a hard boost to compressor motor at each start up.

Usage Guideline:

Required for reciprocating compressors in the following applications:

Long line

Low ambient cooling

Hard shut off expansion valve on indoor coil

Liquid line solenoid on indoor coil

Required for single-phase scroll compressors in the following applications:

Long line

Low ambient cooling

Suggested for all compressors in areas with a history of low voltage problems.

3. Compressor Start Assist — PTC Type

Solid state electrical device which gives a soft boost to the compressor at each start-up.

Usage Guideline:

Suggested in installations with marginal power supply.

4. Crankcase Heater

An electric resistance heater which mounts to the base of the compressor to keep the lubricant warm during off cycles. Improves compressor lubrication on restart and minimizes the chance of liquid slugging.

Usage Guideline:

Required in low ambient cooling applications.

Required in long line applications.

Suggested in all commercial applications.

5. Evaporator Freeze Thermostat

An SPST temperature-actuated switch that stops unit operation when evaporator reaches freeze-up conditions.

Usage Guideline:

Required when low ambient kit has been added.

6. Isolation Relay

An SPDT relay which switches the low-ambient controller out of the outdoor fan motor circuit when the heat pump switches to heating mode.

Usage Guideline:

Required in all heat pumps where low ambient kit has been added.

7. Liquid-Line Solenoid Valve (LLS)

An electrically operated shutoff valve which stops and starts refrigerant liquid flow in response to compressor operation. It is to be installed at the outdoor unit to control refrigerant off cycle migration in the heating mode.

Usage Guideline:

An LLS is required in all long line heat pump applications to control refrigerant off cycle migration in the heating mode. See Long Line Guideline.

8. Low-Ambient Pressure Switch Kit

A long life pressure switch which is mounted to outdoor unit service valve. It is designed to cycle the outdoor fan motor in order to maintain head pressure within normal operating limits. The control will maintain working head pressure at low-ambient temperatures down to 0°F (-17.8°C) when properly installed.

Usage Guideline:

A Low-Ambient Pressure Switch

Low-Ambient Controller must be used when cooling operation is used at outdoor temperatures below 55°F (12.8°C).

9. Sound Jacket

Wraparound sound reducing cover for the compressor. Reduces the sound level by about 2 dBA.

Usage Guideline:

Suggested when unit is installed closer than 15 ft. (4.577 m) to quiet areas, bedrooms, etc.

Suggested when unit is installed between two houses less than 10 ft. (3.05 m) apart.

10. Thermostatic Expansion Valve (TXV) Bi-Flow

A modulating flow-control valve which meters refrigerant liquid flow rate into the evaporator in response to the superheat of the refrigerant gas leaving the evaporator.

Usage Guideline:

Accessory required to meet AHRI rating and system reliability, where indoor not equipped.

Required in all heat pump applications designed with R-410A refrigerant.

11. Time-Delay Relay

An SPST delay relay which briefly continues operation of indoor blower motor to provide additional cooling after the compressor cycles off.

Note: Most indoor unit controls include this feature. For those that do not, use the guideline below.

Usage Guideline:

Accessory required to meet AHRI rating, where indoor not equipped.

ACCESSORY USAGE GUIDELINES

Accessory	Required for Low-Ambient Cooling Applications (Below 55°F / 12.8°C)	Required for Long Line Applications*	Required for Sea Coast Applications (Within 2 mi/3.22 km)
Accumulator	Standard	Standard	Standard
Compressor Start Assist Capacitor and Relay	Yes	Yes	No
Crankcase Heater	Yes	Yes	No
Evaporator Freeze Thermostat	Yes	No	No
Hard Shutoff TXV	Yes	Yes	No
Isolation Relay	Yes	No	No
Liquid Line Solenoid Valve	No	See Long-Line Application Guideline	No
Low Ambient Switch	Yes	No	No
Support Feet	Recommended	No	Recommended

* For tubing line sets between 80 and 200 ft. (24.38 and 60.96 m) and/or 20 ft. (6.09 m) vertical differential, refer to Residential Split-System Longline Application Guideline.

ACCESSORIES

Part Number	Description	Used On Model Size
NASA00501CH	Crankcase Heater for Scroll Compressor (208/230 V)	42, 48
NASA00601CH	Crankcase Heater for Scroll Compressor (208/230 V)	18, 24, 30
NASA012SC	Hard Start Kit (Capacitor & Relay)	ALL
NASA001SC	Start Component - PTC Device	ALL
NASA00201FS	Evaporator Freeze Thermostat	ALL
NASA001LS	Liquid Line Solenoid Valve, HP, R-410A	ALL
NASA001TD	Time Delay Relay, Indoor Blower	ALL
NASA001AC	Anti-Cycle Timer (5 minute delay)	ALL
NASA401LA	Low Ambient Pressure Switch	ALL
NASA00101IK	Low Ambient Isolation Relay Kit	ALL
NASA00201SF	Support Feet, 4" (102mm) tall, 5 included	ALL
NASA00101SJ	Sound Jacket, Compressor	ALL
NAEA40501TX	TXV Kit, R-410A - for use with copper or tin fan coils	18, 24, 30
NAEA40601TX	TXV Kit, R-410A - for use with copper or tin fan coils	36, 42
NAEA40701TX	TXV Kit, R-410A - for use with copper or tin fan coils	48, 60
NAEB40501TX	TXV Kit, R-410A - for use with aluminum fan coils	18, 24, 30
NAEB40601TX	TXV Kit, R-410A - for use with aluminum fan coils	36, 42
NAEB40701TX	TXV Kit, R-410A - for use with aluminum fan coils	48, 60