



	<p>3" Duct (Standard): 50 CFM/1.0 Sone @ 0.1 SP, 6.4 Watts 36 CFM/1.2 Sones @ 0.25 SP, 6.3 Watts</p>		
--	---	--	--

Description

Low noise ceiling/wall mount ventilating fan rated for continuous running. Fan has been awarded ENERGY STAR® Most Efficient in 2014. It is HVI, UL, and cUL certified, and can be used to comply with ASHRAE 62.2 (local and whole building continuous operation).

Motor/Blower

- Power Rating of 120 volts/60Hz
- DC Brushless motor engineered to run continuously
- Motor equipped with thermal cutoff fuse
- Removable with permanently lubricated plug-in motor

Housing

- Galvanized steel body
- Detachable 3" diameter duct adapter
- Built-in backdraft damper
- Easy installation

Grille

- Attractive design using ABS material
- Attaches directly to housing with torsion springs

LED Indicator

- Turn the power switch on/off to operate on/off. LED indicator will be green when power is on

Warranty

- 3-year limited warranty

Feature

- For ceiling/wall mount, airflow of 50 CFM (±10%) and 1.0 Sone at 0.1" static pressure
- Power consumption approximately 6.4 Watts with an efficiency rating approximately 8.9 CFM/Watt
- Duct diameter is no less than 3"
- UL and cUL listed for tub/shower enclosure when used with GFCI-protected branch circuit wiring

DC Motor Technology

- Built-in soft start function to increase bearings' life
- Automatically powers OFF when impeller is locked abnormally.

SLM50 Dimensions

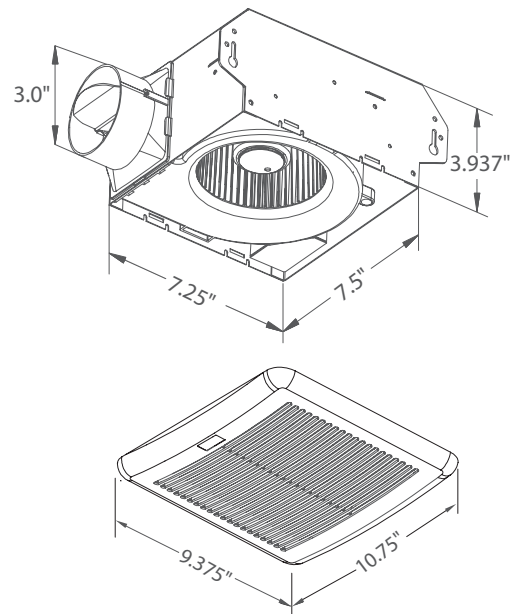

Fan Curve

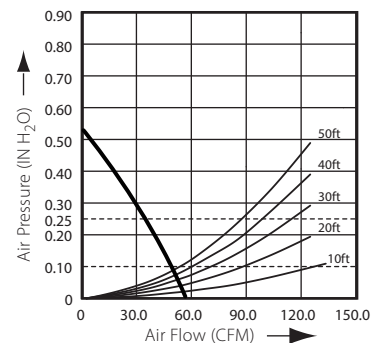

SLM50	3" Duct (Standard)	
Static Pressure (inches w.g.)	0.1	0.25
Air Flow (CFM)	50	36
Sones	1.0	1.2
Power Consumption (Watts)	6.4	6.3
Energy Efficiency (CFM/Watt)	8.9	6.5
Current (Amps)	0.18 Max	
Power Rating (V/Hz)	120 / 60	

Model	Quantity	Comments	Project:
			Location:
			Architect:
			Engineer:
			Contractor:
			Submitted by:
			Date: