

### PACKAGE GAS HEATING/ELECTRIC COOLING, R-410A SINGLE PACKAGE ROOFTOP 3 – 15 TONS (1 & 3 Phase)

#### BUILT TO LAST, EASY TO INSTALL AND SERVICE

- R-410A HFC refrigerant
- ASHRAE 90.1 energy compliant efficiency levels
- Single-stage cooling capacity control on all 036-072 models and the 091,101 and 121 models.
- Two stage cooling capacity control on 090,102,120,150 and 180 models
- Rated in accordance with ARI Standard 210/240 (036-060 sizes) and 340/360 (072-180 sizes)
- Designed in accordance with Underwriters' Laboratories Standard 1995
- Listed by UL and UL, Canada or ETL and ETL, Canada
- Exclusive non-corrosive composite condensate pan in accordance with ASHRAE 62 Standard, sloping design; side or center drain
- Gas efficiencies up to 82%
- Induced draft combustion
- Redundant gas valve, with 1 or 2 stages of heating
- Pre-painted exterior panels and tested to 500 hours salt spray protection
- Fixed refrigerant metering system
- Fully insulated cabinet
- Exclusive IGC solid-state control for on-board diagnostics with LED error code designation, burner control logic.
- "Low NOx" models available that meet California Air Quality Management NOx requirements and include stainless steel heat exchangers
- Cooling operating range from 40 F up to 115 F.
- Access panels with easy grip handles and no-strip screw feature
- Two-inch disposable return air filters
- Tool-less filter access door
- Standard belt drive, constant torque motor
- Advanced terminal board for simple safety circuit troubleshooting and control box arrangement
- Field Convertible from vertical to horizontal airflow on all models. No special kit required on 036-150 models. Field accessory supply duct kit required for 180 size model only
- Provisions for thru-the-bottom power entry capability
- Single point gas and electric connections
- Full perimeter base rail with built-in rigging adapters and fork truck slots
- Scroll compressors with internal line-break overload protection
- Copper tube, aluminum fin coils

- 24-volt control circuit protected with resettable circuit breaker
- Permanently lubricated evaporator-fan motor
- Permanently lubricated, totally enclosed, shaft down condenser motors
- Low pressure, freeze protection, and high pressure switches
- Exclusive IGC anti-cycle protection for gas heat operation
- Solid-state electronic direct spark ignition system
- Flame roll-out safety protector
- Liquid line filter drier

#### WARRANTY

- 15 Year limited warranty on stainless steel heat exchanger
- 10 Year limited warranty on aluminumized heat exchanger
- 5 Year limited warranty on compressor
- 1 Year limited warranty on parts



Use of the AHRI Certified TM Mark indicates a manufacturer's participation in the program. For verification of certification for individual products, go to [www.ahridirectory.org](http://www.ahridirectory.org).



RGS036-072



RGS091-121

#### UNIT PERFORMANCE DATA – Single Stage Cooling

UNIT	Nominal Tons	COOLING			GAS HEATING		Unit Dimensions H x W x L	Unit Weight lb. [kg]
		Net Cap. (Btuh)	SEER	EER	Input Cap. (Btuh)	Thermal Eff. %		
RGS036**AA0AAA	3	34,600	13.0	11.0	72,000-115,000	80-82	33-3/8" x 46-3/4" x 74-3/8"	483 [219]
RGS048**AA0AAA	4	45,000	13.0	11.0	72,000-150,000	80-82	33-3/8" x 46-3/4" x 74-3/8"	537 [244]
RGS060**AA0AAA	5	59,000	13.0	10.8	72,000-150,000	80-82	33-3/8" x 46-3/4" x 74-3/8"	569 [258]
RGS072**AA0AAA	6	70,000	N/A	11.0	72,000-150,000	80-82	41-3/8" x 46-3/4" x 74-3/8"	652 [296]
RGS091**AA0AAA	7-1/2	88,000	N/A	11.0	125,000-224,000	80-82	41-1/4" x 59-1/2" x 88-1/8"	810 [367]
RGS101**AA0AAA	8-1/2	97,000	N/A	11.0	125,000-224,000	82	49-3/8" x 59-1/2" x 88-1/8"	910 [413]
RGS121**AA0AAA	10	117,000	N/A	11.0	180,000-250,000	80-82	49-3/8" x 59-1/2" x 88-1/8"	965 [438]

#### UNIT PERFORMANCE DATA – Dual Stage Cooling

UNIT	Nominal Tons	COOLING			GAS HEATING		Unit Dimensions H x W x L	Unit Weight lb. [kg]
		Net Cap. (Btuh)	SEER	EER	Input Cap. (Btuh)	Thermal Eff. %		
RGS090**AA0AAA	7-1/2	83,000	N/A	11.0	125,000-224,000	82	41-1/4" x 59-1/2" x 88-1/8"	810 [367]
RGS102**AA0AAA	8-1/2	99,000	N/A	11.0	125,000-224,000	80-82	49-3/8" x 59-1/2" x 88-1/8"	910 [413]
RGS120**AA0AAA	10	114,000	N/A	11.1	180,000-250,000	80-82	49-3/8" x 59-1/2" x 88-1/8"	965 [438]
RGS150**AA0AAA	12-1/2	140,000	N/A	10.8	180,000-250,000	80-82	49-3/8" x 59-1/2" x 88-1/8"	1116 [506]
RGS180**AA0AAA	15	174,000	N/A	10.8	180,000-350,000	80-81	57-3/8" x 63-3/8" x 115-7/8"	1380 [627]

#### UNIT PERFORMANCE DATA – Single Stage Cooling Low Nox Models

UNIT	Nominal Tons	COOLING			GAS HEATING		Unit Dimensions H x W x L	Unit Weight lb. [kg]
		Net Cap. (Btuh)	SEER	EER	Input Cap. (Btuh)	Thermal Eff. %		
RGS036**AA0AAA	3	34,600	13.0	11.0	60,000-90,000	80-82	33-3/8" x 46-3/4" x 74-3/8"	483 [219]
RGS048**AA0AAA	4	45,000	13.0	11.0	60,000-120,000	80-82	33-3/8" x 46-3/4" x 74-3/8"	537 [244]
RGS060**AA0AAA	5	59,000	13.0	10.8	60,000-120,000	80-82	33-3/8" x 46-3/4" x 74-3/8"	569 [258]

\* Indicates Unit voltage: K = 208/230-1-60, H = 208/230-3-60, L = 460-3-60, S = 575-3-60

^ See model nomenclature listing for gas heating options.

NOTE: BASE MODEL NUMBERS LISTED. SEE MODEL NOMENCLATURE LISTING FOR ADDITIONAL OPTIONS

# TABLE OF CONTENTS

	PAGE		PAGE
MODEL NOMENCLATURE .....	3	COOLING CAPACITIES .....	37
FACTORY OPTIONS AND/OR ACCESSORIES .....	4	ECONOMIZER, BAROMETRIC RELIEF, AND PE PERFORMANCE .....	58
ACCESSORIES .....	6	FAN PERFORMANCE .....	60
AHRI COOLING RATING .....	13	ELECTRICAL INFORMATION .....	74
SOUND PERFORMANCE TABLE .....	15	SEQUENCE OF OPERATION .....	84
PHYSICAL DATA .....	17	ALTITUDE COMPENSATION TABLES .....	87
BASE UNIT DIMENSIONS .....	22	GUIDE SPECIFICATIONS .....	89
OPTIONS & ACCESSORY WEIGHTS .....	33		
APPLICATION DATA .....	34		

<b>FACTORY-INSTALLED OPTION DESCRIPTIONS (Use with Model Nomenclature on next page)</b>		
OPTION	DESCRIPTION	NOTES
2	Non-Fused Disconnect Switch	1, 2
4	Easy Access Hinged Panels	4
5	Unpowered Convenience Outlet	3
9	Supply Air Smoke Detector	

**NOTES:**

1. Non-fused disconnect switch (036-150 sizes) cannot be used when rooftop FLA electrical rating exceeds 80 amps (all voltages).
2. Non-fused disconnect switch (180 size) cannot be used when unit FLA exceeds 100 amps (all voltages).
3. Un-powered convenience outlet requires separate field supplied 115-120v power source. Transformer is NOT included.
4. Easy access hinged panels include: Filter, Control Box, Fan Motor and Compressor

NOMENCLATURE CODE	OPTIONS
0A	None
4B	2
7C	2, 5
7K	2, 5, 9
8A	2, 9
AT	5
BA	5, 9
AA	4
6C	2, 4
6D	2, 4, 5
6L	2, 4, 5, 9
7B	2, 4, 9
BR	9
AB	4, 5
AJ	4, 5, 9
CH	4, 9

# MODEL NOMENCLATURE

MODEL SERIES	R	G	S	0	9	1	H	D	A	A	0	A	A	A
Position Number	1	2	3	4	5	6	7	8	9	10	11	12	13	14
R = Rooftop														
G = Gas/Electric <span style="float: right;">Type</span>														
S = Standard ASHRAE 90.1-2010 Efficiency <span style="float: right;">Efficiency</span>														
036 = 3 Tons 048 = 4 Tons 060 = 5 Tons 072 = 6 Tons 091 = 7.5 Tons (Single Compressor) 101 = 8.5 Tons (Single Compressor) 121 = 10 Tons (Single Compressor) <span style="float: right;">090 = 7.5 Tons (Dual Compressor)            102 = 8.5 Tons (Dual Compressor)            120 = 10 Tons (Dual Compressor)            150 = 12.5 Tons (Dual Compressor)            180 = 15 Tons (Dual Compressor)</span>														
<b>Nominal Cooling Capacity</b>														
K = 208/230-1-60 H = 208/230-3-60 L = 460-3-60 S = 575-3-60 <span style="float: right;">Voltage</span>														
D = Low Heat E = Medium Heat F = High Heat L = Low Heat, Low NOx M = Medium Heat, Low NOx N = High Heat, Low NOx S = Low Heat, Stainless Steel Heat Exchanger R = Medium Heat, Stainless Steel Heat Exchanger T = High Heat, Stainless Steel Heat Exchanger <span style="float: right;">Heating Capacity</span>														
A = Standard Motor (3 to 15 Ton) C = Medium Static Motor (3 to 15 Ton) B = High Static Motor (3-12.5 ton, 1 Speed, 3 phase models only, 7.5 to 15 ton, 2 speed) E = High Static Motor , High Efficiency Motor (15 ton only) G = High Static Motor with Hot Gas Reheat (15 ton only) H = High Static Motor with Hot Gas ReHeat (3 to 12.5 ton, 1-speed motors), (7.5 to 15 ton, 2-speed motors) <span style="float: right;">Motor Option (Indoor Fan)</span>														
A = None B = Economizer w/Bara-relief, OA Temp sensor E = Economizer w/Bara-relief + CO2 Sensor, OA Temp sensor H = Economizer w/Bara-relief, enthalpy sensor L = Economizer w/Bara-relief + CO2 Sensor, enthalpy sensor U = Temp Ultra Low Leak Economizer w/Bara-relief W = Enthalpy Ultra Low Leak Economizer w/Bara-relief P = 2-Position damper <span style="float: right;">Outdoor Air Options / Control <sup>1</sup></span>														
OA = No Options AT = Non-powered 115v C.O. 4B = Non-Fused Disconnect BR = Supply Air Smoke Detector AA = Easy Access Hinged Panels <span style="float: right;">Factory Installed Options</span>														
A = Aluminum / Copper Cond & Evap Coil B = Precoat Alum/Copper Cond with Alum / Copper Evap (3 phase only) C = E-Coated Alum/Copper Cond with Alum / Copper Evap (3 phase only) D = E-Coated Alum / Copper Cond & Evap (3 phase only) E = Copper/Copper Cond & Alum/Copper Evap (3 phase only) F = Copper/Copper Cond & Evap (3 phase only) <span style="float: right;">Condenser / Evaporator Coil Configuration</span>														
A = Standard Sinle Speed Indoor Fan Motor. For W7212 Controls B = Standard Sinle Speed Indoor Fan Motor. For W7220 Controls T = 2 Speed Indoor Motor VFD Controller (For 2-stage units only) <span style="float: right;">Motor Type Option</span>														

**NOTE:** Factory installed options are NOT available on single phase models. This includes economizers and 2 position dampers.

<sup>1</sup> A combinations of FIOPS are available.

**Table 1 – FACTORY INSTALLED OPTIONS AND FIELD INSTALLED ACCESSORIES**

CATEGORY	ITEM	FACTORY INSTALLED OPTION	FIELD INSTALLED ACCESSORY
<b>Cabinet</b>	Thru-the-base electrical or gas-line connections		X
	Hinged Access Panels	X	
	Supply Duct Cover (15 ton only)		X
<b>Coil Options</b>	Copper/Copper indoor and/or outdoor coils <sup>5</sup>	X	
	Pre-coated outdoor coils <sup>5</sup>	X	
	Premium, E-coated outdoor coils <sup>5</sup>	X	
<b>Condenser Protection</b>	Condenser coil hail guard (louvered design) <sup>5</sup>		X
<b>Humidity Control</b>	Hot Gas Re-Heat Dehumidification System <sup>1</sup>	X	
<b>Controls</b>	Smoke detector (supply air)	X	
	Time Guard II compressor delay control circuit		X
	Phase Monitor		X
<b>Economizers &amp; Outdoor Air Dampers</b>	Economizer (for electro-mechanical controlled RTUs) <sup>5,6</sup>	X	X
	Low Leak Economizer X. Vertical supply/return only <sup>5,6</sup>	X	X
	Motorized 2 position outdoor-air damper <sup>5</sup>	X	X
	Manual outdoor-air damper		X
	Barometric relief <sup>1</sup>	X	X
	Power exhaust		X
<b>Economizer Sensors &amp; IAQ Devices</b>	Single dry bulb temperature sensors <sup>2</sup>	X	X
	Single enthalpy sensors <sup>2</sup>	X	X
	Differential enthalpy sensors <sup>2</sup>		X
	CO <sub>2</sub> sensor (wall, duct, or unit mounted) <sup>2</sup>		X
<b>Gas Heat</b>	Liquid propane (LP) conversion kit		X
	High altitude conversion kit		X
	Flue Shield (036-150 sizes only)		X
	Flue Discharge Deflector (036-150 sizes only)		X
	Stainless Steel Heat Exchanger	X	
<b>Indoor Motor &amp; Drive</b>	Multiple motor and drive packages	X	
	2-Speed VFD drive motor system	X	
	VFD Remote keypad kit		X
<b>Low Ambient Control</b>	Winter start kit <sup>3</sup>		X
	Head pressure controller <sup>3</sup>		X
<b>Power Options</b>	Convenience outlet (unpowered)	X	
	Non-fused disconnect <sup>4</sup>	X	
<b>Roof Curbs</b>	Roof curb 14" (356mm)		X
	Roof curb 24" (610mm)		X

**NOTES:**

- Included with economizer.
- Sensors used to optimize economizer performance.
- See application data for assistance.
- Available on units with MOCP's of 80 amps or less.
- Not available as factory installed option on single phase (208/230/1/60) models. Use field-installed accessory where available.
- FDD (Fault Detection and Diagnostic) capability per California Title 24 section 120.2.

**FACTORY OPTIONS AND/OR ACCESSORIES**

**2-Speed VFD Drive Motor**

The 2-speed VFD drive motor system saves energy and installation time by utilizing a Variable Frequency Drive (VFD) to automatically adjust the indoor fan motor speed in sequence with the units cooling operation. Per ASHRAE 90.1 2010 standard section 6.4.3.10.b, during the first stage of cooling operation the VFD will adjust the fan motor to provide 2/3rd of the total cfm established for the unit. When a call for the second stage of cooling is required, the VFD will allow the total cfm for the unit established (100%). During the heating mode the VFD will allow total design cfm (100%) operation and during the ventilation mode the VFD will allow operation to 2/3rd of total cfm.

Compared to single speed indoor fan motor systems, 2 speed system can save substantial energy, 25%+, versus single speed indoor fan motor systems.

The VFD used in the system has soft start capabilities to slowly ramp up the speeds, thus eliminating any high inrush air volume during initial start-up. It also has internal over-current protection

for the fan motor and a field installed display kit that allows adjustment and in depth diagnostics of the VFD.

This system is available on models with 2-stage cooling operation with electro-mechanical controls. Both space sensor and conventional thermostats/controls can be used to provide accurate control in any application.

The system is very flexible for initial fan performance set up and adjustment. The standard factory shipped VFD is pre-programmed to automatically stage the fan speed between the first and second stage of cooling. The unit fan performance static pressure and cfm can be easily adjusted using the traditional means of pulley adjustments. The other means to adjust the unit static and cfm performance is to utilize the field installed Display Kit and adjust the frequency and voltage in the VFD to performance requirements. In either case, once set up, the VFD will automatically adjust the speed between the cooling stage operations.

## **Economizer**

Economizers save energy, money and improve comfort levels in the conditioned space: They bring in fresh, outside air for ventilation; and provide cool outside air to cool your building. This also is the preferred method of low ambient cooling. When integrated with CO<sub>2</sub> sensors, economizers can provide even more savings by coupling the ventilation air to only that amount required based on space occupancy.

Economizers are available, installed and tested by the factory, with either enthalpy or temperature dry – bulb inputs. There are also models for electromechanical and single speed fan or 2 speed indoor fan motors. Additional sensors are available as accessories to optimize the economizer. Economizers include gravity controlled barometric relief that helps equalize building pressure and ambient air pressures. This can be a cost effective solution to prevent building pressurization.

Economizers are available in Ultra Low Leak and standard low leak versions.

## **CO<sub>2</sub> Sensor**

Improves productivity and saves money by working with the economizer to intake only the correct amount of outside air for ventilation. As occupants fill your building, the CO<sub>2</sub> sensor detects their presence through increasing CO<sub>2</sub> levels, and opens the economizer appropriately.

When the occupants leave, the CO<sub>2</sub> levels decrease, and the sensor appropriately closes the economizer. This intelligent control of the ventilation air, called Demand Control Ventilation (DCV) reduces the overall load on the rooftop, saving money. CO<sub>2</sub> sensors are available with the economizer, installed and tested by the factory.

## **Smoke Detectors**

Smoke detectors immediately shut down the rooftop unit when smoke is detected. Supply air smoke detectors are available, installed by the factory.

## **Louvered Hail Guards**

Sleek, accessory louvered panels protect the condenser coil from hail damage, foreign objects, and incidental contact.

## **Convenience Outlet (un-powered)**

Lower service bills by including a convenience outlet in your specification. Provides a convenient, 15 amp, 115v GFCI receptacle.

## **Non-fused Disconnect**

This OSHA-compliant, factory-installed, safety switch allows a service technician to locally secure power to the rooftop.

## **Barometric Relief**

Gravity controlled, barometric relief equalizes building pressure and ambient air pressures. This can be a cost effective solution to prevent building pressurization.

## **Power Exhaust**

Superior internal building pressure control. This field-installed accessory may eliminate the need for costly, external pressure control fans.

## **Time Guard II Control Circuit**

This accessory protects your compressor by preventing short-cycling in the event of some other failure, prevents the compressor from restarting for 30 seconds after stopping. Not required with authorized commercial thermostats.

## **Motorized 2-Position Damper**

A 2-position, motorized outdoor air damper is available factory installed and admits up to 100% outside air. Using reliable, gear-driven technology, the 2-position damper opens to allow ventilation air and closes when the rooftop stops, stopping unwanted infiltration.

## **Manual OA Damper**

Accessory manual outdoor air dampers are an economical way to bring in ventilation air.

## **Head Pressure Controller**

The motor controller is a low ambient, head pressure controller kit that is designed to maintain the unit's condenser head pressure during periods of low ambient cooling operation. This device should be used as an alternative to economizer free cooling not when economizer usage is either not appropriate or desired. The controller will either cycle the outdoor-fan motors or operate them at reduced speed to maintain the unit operation, depending on the model.

## **Winter Start Kit**

The accessory winter start kit extends the low ambient limit of your rooftop to 25°F (-9°C). The kit bypasses the low pressure switch, preventing nuisance tripping of the low pressure switch. Other low ambient precautions may still be prudent.

## **Liquid Propane Heating**

Convert your gas heat rooftop from standard natural gas operation to liquid propane using this field-installed kit.

## **High Altitude Heating**

High altitudes have less oxygen, which means heat exchangers need less fuel. The new gas orifices in this field-installed kit make the necessary adjustment for high altitude applications. They restore the optimal fuel to air mixture and maintain healthy combustion at altitudes above 2000 ft (610m). Kits may not be required in all areas.

## **Flue Discharge Deflector**

The flue discharge deflector is a useful accessory when flue gas recirculation is a concern. By venting the flue discharge upwards, the deflector minimizes the chance for a neighboring unit to intake the flue exhaust.

## **Stainless Steel Heat Exchanger (Optional)**

The stainless steel heat exchanger option provides the tubular heat exchanger be made out of a minimum 20 gage type 409 stainless steel for applications where the mixed air to the heat exchanger is expected to drop below 45°F (7°C). Stainless steel may be specified on applications where the presence of airborne contaminants require its use ( applications such as paper mills ) or in areas with very high outdoor humidity that may result in severe condensation in the heat exchanger during cooling operation.

## **Flue Discharge Heat Shield**

The flue discharge heat shield keeps people from touching the rooftop unit's potentially hot flue discharge. This is especially useful for ground level applications, where more, untrained people could have access to the unit's exterior.

## **Alternate Motors and Drives**

Some applications need larger horsepower motors, some need more airflow, and some need both. Regardless of the case, your unit has a factory installed combination to meet your application. A wide selection of motors and pulleys (drives) are available, factory installed, to handle nearly any application.

## **Thru-the-Base Connections**

Thru-the-base connections, available as accessory, are necessary to ensure proper connection and seal when routing wire and piping through the rooftop's basepan and curb. These couplings eliminate roof penetration and should be considered for gas lines, main power lines, as well as control power.

## **Supply Duct Cover**

This supply duct cover is required when field converting the factory standard vertical duct supply to horizontal duct supply configuration. One required per unit. (180 size only)

## **Optional Hot Gas Reheat System**

The Hot Gas Reheat System is an all-inclusive factory-installed option that can be ordered with any 3 phase RGS unit.

This system expands the envelope of operation of our rooftop products to provide unprecedented flexibility to meet year-round comfort conditions.

The Hot Gas Reheat System has the industry's only dual dehumidification mode setting. The Hot Gas Reheat System includes two new modes of operation.

The RGS rooftop coupled with the Hot Gas Reheat system is capable of operating in normal design cooling mode, subcooling mode, and hot gas reheat mode. Normal design cooling mode is when the unit will operate under its normal sequence of operation by cycling compressors to maintain comfort conditions.

Subcooling mode will operate to satisfy part load type conditions when the space requires combined sensible and a higher proportion of latent load control. Hot Gas Reheat mode will operate when outdoor temperatures diminish and the need for latent capacity is required for sole humidity control. Hot Gas Reheat mode will provide neutral air for maximum dehumidification operation.

## **Hinged Access Panels**

Allows access to unit's major components with specifically designed hinged access panels. Panels are: filters, control box, fan motor and compressor.

## ACCESSORIES – RGS036–180

<b>ECONOMIZERS</b>			
<b>ECONOMIZER IV (FOR 1-SPEED INDOOR FAN MOTOR ONLY) – STANDARD LEAK CONTROLLER INCLUDED</b>			
<b>VERTICAL</b>			
<b>Model Number</b>	<b>Description</b>	<b>Use With Model Size</b>	<b>Approx Ship Wt. LBS (KGS)</b>
CRECOMZR020A02	STANDARD LEAK Vertical EconoMi\$er IV with solid-state controller, gear-driven, damper, spring return actuator, up to 100% barometric relief, supply and outdoor air temperature sensors, and CO2 sensor compatible, for use in non-DDC applications.	036-072 Elect Mech Controls	55 (25)
CRECOMZR021A03	STANDARD LEAK Vertical EconoMi\$er IV with solid-state controller, gear-driven, modulating damper, spring return actuator, up to 100% barometric relief, supply and outdoor air temperature sensors, and CO2 sensor compatible, for use in non-DDC applications.	090-150 Elect Mech Controls	80 (36)
CRECOMZR062A00	STANDARD LEAK Vertical EconoMi\$er IV with solid-state controller, gear-driven, modulating damper, spring return actuator, up to 100% barometric relief, supply and outdoor air temperature sensors, and CO2 sensor compatible, for use in non-DDC applications.	180 Elect Mech Controls	100 (45)

<sup>1</sup> EconoMi\$er IV cannot be installed with an EconoMi\$er X, Manual Damper, or Motorized Damper.

<sup>2</sup> When installed on a unit with hinged panels, hinged panel access kit is also required.

<b>HORIZONTAL</b>			
<b>Model Number</b>	<b>Description</b>	<b>Use With Model Size</b>	<b>Approx Ship Wt. LBS (KGS)</b>
CRECOMZR024A02	STANDARD LEAK Horizontal EconoMi\$er IV with solid-state controller, gear-driven, modulating damper, spring return actuator, up to 100% barometric relief, supply and outdoor air temperature sensors, and CO2 sensor compatible, for use in non-DDC applications.	036-072 Elect Mech Controls	85 (39)
CRECOMZR025A02	STANDARD LEAK Horizontal EconoMi\$er IV with solid-state controller, gear-driven, modulating damper, spring return actuator, up to 100% barometric relief, supply and outdoor air temperature sensors, and CO2 sensor compatible, for use in non-DDC applications.	090-150 Elect Mech Controls	105 (48)
CRECOMZR064A00	STANDARD LEAK Horizontal EconoMi\$er IV with solid-state controller, gear-driven, modulating damper, spring return actuator, up to 100% barometric relief, supply and outdoor air temperature sensors, and CO2 sensor compatible, for use in non-DDC applications.	18 Elect Mech Controls	115 (52)

<sup>1</sup> EconoMi\$er IV cannot be installed with an EconoMi\$er X, Manual Damper, or Motorized Damper.

<sup>2</sup> When installed on a unit with hinged panels, hinged panel access kit is also required.

<b>ECONOMIZER X (FOR 1 &amp; 2-SPEED INDOOR FAN MOTOR) – STANDARD LEAK, CONTROLLER INCLUDED</b>			
<b>VERTICAL</b>			
<b>Model Number</b>	<b>Description</b>	<b>Use With Model Size</b>	<b>Approx Ship Wt. LBS (KGS)</b>
CRECOMZR076A00	STANDARD LEAK - Vertical EconoMi\$er X with solid-state W7220 controller, gear-driven, modulating damper, spring return actuator, up to 100% barometric relief, supply and outdoor air temperature sensors, and CO2 sensor compatible, for use in electro mechanical controls only. Controller meets California Title 24 Section 120.2 Fault Detection and Diagnostic (FDD) requirements.	036-072 Elect Mech Controls	105
CRECOMZR078A00	STANDARD LEAK - Vertical EconoMi\$er X with solid-state W7220 controller, gear-driven, modulating damper, spring return actuator, up to 100% barometric relief, supply and outdoor air temperature sensors, and CO2 sensor compatible, for use in electro mechanical controls only. Controller meets California Title 24 Section 120.2 Fault Detection and Diagnostic (FDD) requirements.	090-150 Elect Mech Controls	105
CRECOMZR080A00	STANDARD LEAK - Vertical EconoMi\$er X with solid-state W7220 controller, gear-driven, modulating damper, spring return actuator, up to 100% barometric relief, supply and outdoor air temperature sensors, and CO2 sensor compatible, for use in electro mechanical controls only. Controller meets California Title 24 Section 120.2 Fault Detection and Diagnostic (FDD) requirements.	180 Elect Mech Controls	115

<sup>1</sup> EconoMi\$er X cannot be installed with an EconoMi\$er IV, Manual Damper or Motorized Damper.

<sup>2</sup> When installed on a unit with hinged panels, hinged panel access kit is also required.

## ACCESSORIES – RGS036–180 (cont.)

HORIZONTAL			
Model Number	Description	Use With Model Size	Approx Ship Wt. LBS (KGS)
CRECOMZR077A00	STANDARD LEAK - Horizontal EconoMi\$er X with solid-state W7220 controller, gear-driven, modulating damper, spring return actuator, up to 100% barometric relief, supply and outdoor air temperature sensors, and CO2 sensor compatible, for use in electro mechanical controls only. Controller meets California title 24 Section 120.2 Fault Detection and Diagnostic (FDD) requirements.	036-072 Elect Mech Controls	105
CRECOMZR079A00	STANDARD LEAK - Horizontal EconoMi\$er X with solid-state W7220 controller, gear-driven, modulating damper, spring return actuator, up to 100% barometric relief, supply and outdoor air temperature sensors, and CO2 sensor compatible, for use in electro mechanical controls only. Controller meets California Title 24 Section 120.2 Fault Detection and Diagnostic (FDD) requirements.	090-150 Elect Mech Controls	105
CRECOMZR081A00	STANDARD LEAK - Horizontal EconoMi\$er X with solid-state W7220 controller, gear-driven, modulating damper, spring return actuator, up to 100% barometric relief, supply and outdoor air sensors, and CO2 sensor compatible, for use in electro mechanical controls only. Controller meets California Title 24 Section 120.2 Fault Detection and Diagnostic (FDD) requirements.	180 Elect Mech Controls	115

<sup>1</sup> EconoMi\$er X cannot be installed with an EconoMi\$er IV, Manual Damper or Motorized Damper.

<sup>2</sup> When installed on a unit with hinged panels, hinged panel access kit is also required.

### ECONOMI\$ER X (FOR 1 & 2-SPEED INDOOR FAN MOTOR) – ULTRA LOW LEAK, CONTROLLER INCLUDED

VERTICAL			
Model Number	Description	Use With Model Size	Approx Ship Wt. LBS (KGS)
CRECOMZR067A00	Ultra LOW LEAK - Vertical EconoMi\$er X with solid-state W7220 controller, gear-driven, modulating damper, spring return actuator, up to 100% barometric relief, supply and outdoor air temperature sensors, and CO2 sensor compatible, for use in electro mechanical controls only. Also includes return , outside air, and relief air damper leakage that meets Title 24 section 140.4 and ASHRAE 90.1 requirements. Controller meets California Title 24 Fault Detection and Diagnostic (FDD) requirements.	036-072 Elect Mech Controls	105
CRECOMZR069A00	Ultra LOW LEAK - Vertical EconoMi\$er X with solid-state W7220 controller, gear-driven, modulating damper, spring return actuator, up to 100% barometric relief, supply and outdoor air temperature sensors, and CO2 sensor compatible, for use in electro mechanical controls only. Also includes return , outside air, and relief air damper leakage that meets Title 24 section 140.4 and ASHRAE 90.1 requirements. Controller meets California Title 24 Fault Detection and Diagnostic (FDD) requirements.	090-150 Elect Mech Controls	105
CRECOMZR071A00	Ultra LOW LEAK - Vertical EconoMi\$er X with solid-state W7220 controller, gear-driven, modulating damper, spring return actuator, up to 100% barometric relief, supply and outdoor air sensors, and CO2 sensor compatible, for use in electro mechanical controls only. Also includes return , outside air, and relief air damper leakage that meets Title 24 section 140.4 and ASHRAE 90.1 requirements. Controller meets California Title 24 Fault Detection and Diagnostic (FDD) requirements.	180 Elect Mech Controls	115

<sup>1</sup> EconoMi\$er X cannot be installed with an EconoMi\$er IV, Manual Damper or Motorized Damper.

<sup>2</sup> Currently only available on vertical air flow configuration models. Contact your local MicroMetl account manager 1-800-884-4662 if horizontal model is required.

<sup>3</sup> When installed on a unit with hinged panels, hinged panel access kit is also required.

## ACCESSORIES – RGS036–180 (cont.)

ACCESSORY KITS FOR UNITS WITH HINGED ACCESS PANELS		
VERTICAL		
Model Number	Description	Use With Model Size
CRPECONV003A00	Vertical accessory kit is required when field installing a vertical economizer on a unit that has hinged access panels. Includes angle and seal strip.	036-072
CRPECONV004A00	Vertical accessory kit is required when field installing a vertical economizer on a unit that has hinged access panels. Includes angle and seal strip.	090-150
CRPECONV007BA00	Vertical & Horizontal accessory kit is required when field installing a 2-position damper or vertical & horizontal economizer on a unit that has hinged access panels. Includes angle and seal strip.	180
HORIZONTAL		
Model Number	Description	Use With Model Size
CRHNGPNL001A00	Horizontal accessory kit is required when field installing a horizontal economizer on a unit that has hinged access panels. Includes door panel, angle and seal strip.	036-072
CRHNGPNL002A00	Horizontal accessory kit is required when field installing a horizontal economizer on a unit that has hinged access panels. Includes door panel, angle and seal strip.	090-150
CRHNGPNL003A00	Currently in development - please contact application engineering ... Horizontal accessory kit is required when field installing a horizontal economizer, power exhaust, 2-position damper or manual damper on a unit that has hinged access panels. Includes door panel, angle and seal strip.	180

ECONOMIZER SENSORS		
Model Number	Description	Use With Model Size
DNTEMPSN002A00	Outdoor or Return Dry Bulb Temperature Sensor used with Electro-Mechanical control.	Economizer IV
DNCBDIOX005A00	CO <sub>2</sub> Sensor for use in return airstream. Also includes Aspirator Box required for Duct Mounting.	Economizer IV & X
DNENTDIF004A00	Return Air Enthalpy Sensor used with Electro-Mechanical controls, use with AXB078ENT for differential enthalpy control.	Economizer IV
AXB078ENT	Accusensor II Economizer Differential Enthalpy Control Upgrade	Economizer IV
CRTEMPSN005A00	Outdoor or return dry bulb temperature sensor used with Honeywell W7220 electro-mechanical control.	Economizer X
--HH--57AC-081	Enthalpy control for W7220 controller only. (One required for single enthalpy, two required for differential enthalpy)	Economizer X

NOTE: Supply air temperature sensor (SAT and low ambient lockout switch) provided with economizer IV or economizer X.

<sup>1</sup> Supply air temperature sensor (SAT and low ambient lockout switch) provided with Economizer IV or Economizer X.

ECONOMIZER SENSOR USAGE CHART			
DESIRED CONTROL METHOD		ECONOMIZER IV <sup>1</sup>	
		REQUIRED FIELD-INSTALLED SENSOR(S)	
		ECONOMIZER X <sup>1</sup>	
		REQUIRED FIELD-INSTALLED SENSOR(S)	
Single Dry Bulb Control		None. Outside Air dry bulb sensor is factory installed.	
Single Enthalpy Control		(1) AXB078ENT	
Differential Dry Bulb		NA	
Differential Enthalpy Control		(1) AXB078ENT & (1) DNENTDIF004A00	
To Add CO <sub>2</sub> DCV Control with above:	Duct Mount	(1) DNCBDIOX005A00	

<sup>1</sup> OAT and SAT sensors included for Economizer IV or Economizer X



## ACCESSORIES – RGS036–180 (cont.)

POWER EXHAUST		
VERTICAL <sup>1, 2</sup>		
Model Number	Description	Use With Model Size
DNPWREXH030A01	Vertical Power Exhaust 208/230 volt (1 or 3 Phase)	036 – 072
DNPWREXH021A01	Vertical Power Exhaust 460 volt	036 – 072
DNPWREXH022A01	Vertical Power Exhaust 208/230 volt (1 or 3 Phase)	090 – 150
DNPWREXH023A01	Vertical Power Exhaust 460 volt	090 – 150
DNPWREXH080A00	Vertical Power Exhaust 208/230 volt	180
DNPWREXH081A00	Vertical Power Exhaust 460 volt	180

<sup>1</sup> Vertical Power Exhaust requires a vertical Economizer

<sup>2</sup> Vertical Power Exhaust package includes exhaust hood, screens, and propeller fan system

HORIZONTAL <sup>1, 2</sup>		
Model Number	Description	Use With Model Size
DNPWREXH028A01	Horizontal Power Exhaust 208/230 & 575 volt (1 or 3 Phase)	036 – 180
DNPWREXH029A01	Horizontal Power Exhaust 460 volt	036 – 180
DNPWREXH082A00	Horizontal Power Exhaust 208/230 & 575 volt (Mounted on return ductwork)	180
DNPWREXH083A00	Horizontal Power Exhaust 460 volt (Mounted on return ductwork)	180

<sup>1</sup> Horizontal Power Exhaust should be duct-mounted in the return duct and is supplied with a single fan and wiring harness

<sup>2</sup> Horizontal Power Exhaust package includes exhaust hood, screens, and propeller fan system

575V TRANSFORMER		
Model Number	Description	Use With Model Size
1171494 *	Transformer for conversion from 575v to 208/230v power exhaust applications.	ALL

**NOTE:**

1. 24" Roof curbs are NOT required with vertical power exhaust.

2. Both vertical and horizontal power exhaust packages can be used with either EconoMi\$er IV or EconoMi\$er X. In either case, the power exhaust is controlled by the EconoMi\$er IV, X controller.

\* Order --HT--01AH-859, FAST# 1171494, for 575V applications.

SPECIAL – 180 SIZE SPECIFIC ACCESSORIES		
Model Number	Description	Use With Model Size
CRDISBKT001A00	Disconnect Switch Bracket - Provides a pre-engineered and sized mounting bracket for applications requiring a unit mounted fused and non-fused disconnect of greater than 100 amps. Bracket assures that no damage will occur to coils when mounting with screws and other fasteners.	180
CRDUCTCV002A00	Supply Duct Cover - This supply duct cover is required when field converting the factory standard vertical duct supply to horizontal duct supply configuration. One required per unit.	180

MANUAL OUTDOOR AIR DAMPERS		
Model Number	Description	Use With Model Size
CRMANDPR001A03	25% Open Manual Fresh Air Damper	036 – 072
CRMANDPR001A02	50% Open Manual Fresh Air Damper	036 – 072
CRMANDPR002A03	25% Open Manual Fresh Air Damper	090 – 150
CRMANDPR002A02	50% Open Manual Fresh Air Damper	090 – 150
CRMANDPR011A00	50% Open Manual Fresh Air Damper	180

MOTORIZED OUTDOOR AIR DAMPERS		
Model Number	Description	Use With Model Size
CRTWOPOS010A00	Motorized 2 position outdoor air damper (25–100% Outdoor Air)	036 – 072
CRTWOPOS011A00	Motorized 2 position outdoor air damper (25–100% Outdoor Air)	090 – 150
CRTWOPOS014A00	Motorized 2 position outdoor air damper (25–100% Outdoor Air)	180

**NOTE:** Economizer IV, Economizer X, Manual Damper and 2–Position damper are all mutually exclusive and cannot be installed together.

- Manual dampers include hood assembly, bird screen, adjustable damper blade (to allow up to the rated outdoor air %), and bottom panel with opening.
- Motorized dampers include bottom panel with opening (100% two–position damper includes 30% barometric relief capability), and adjustable damper (to allow up to the rated outdoor air %)
- Motorized dampers will close on loss of power to the rooftop unit.  
Manual and motorized dampers are not compatible with a vertical power exhaust module.

## ACCESSORIES – RGS036–180 (cont.)

<b>LOUVERED HAIL GUARDS – CONDENSER COIL</b>		
<b>Model Number</b>	<b>Description</b>	<b>Use With Model Size</b>
CRLVHLGD011A00	Louvered Condenser Coil Hail Guard -- Includes louvered panel(s) to protect condenser coil from damage and vandalism.	036
CRLVHLGD012A00	Louvered Condenser Coil Hail Guard -- Includes louvered panel(s) to protect condenser coil from damage and vandalism.	048-060
CRLVHLGD013A00	Louvered Condenser Coil Hail Guard -- Includes louvered panel(s) to protect condenser coil from damage and vandalism.	072
CRLVHLGD014A00	Louvered Condenser Coil Hail Guard -- Includes louvered panel(s) to protect condenser coil from damage and vandalism.	090-091
CRLVHLGD015A00	Louvered Condenser Coil Hail Guard -- Includes louvered panel(s) to protect condenser coil from damage and vandalism.	101
CRLVHLGD016A00	Louvered Condenser Coil Hail Guard -- Includes louvered panel(s) to protect condenser coil from damage and vandalism.	102-150
CRLVHLGD032A00	Louvered Condenser Coil Hail Guard -- Includes louvered panel(s) to protect condenser coil from damage and vandalism.	180

<b>STANDARD ROOF CURBS</b>		
<b>Model Number</b>	<b>Description</b>	<b>Use With Model Size</b>
CRRFCURB001A01	14" (356 mm) High Roof Curb. Ductwork attaches to the roof curb. Includes thru-the-bottom capability.	036 – 072
CRRFCURB003A01		090 – 150
CRRFCURB074A00		180
CRRFCURB002A01	24" (607 mm) High Roof Curb. Ductwork attaches to the roof curb. Includes thru-the-bottom capability.	036 – 072
CRRFCURB004A01		090 – 150
CRRFCURB075A00		180

<b>THROUGH-THE-BOTTOM/CURB POWER CONNECTION</b>		
<b>Model Number</b>	<b>Description</b>	<b>Use With Model Size</b>
CRBTMPWR001A01	Thru-the-bottom electrical connections and thru-the-curb (not thru the bottom) gas connections. Includes a 3/4-inch (19 mm) diameter liquid tight conduit fitting for high voltage power wires and (2) 1/2-inch (13 mm) diameter liquid tight conduit fittings for thermostat wires and convenience outlet wires. Includes a 3/4-inch (19 mm) inside pipe coupling and gas plate assembly for thru-the-curb connections. Provides for watertight seals.	036-072
CRBTMPWR003A01	Thru-the bottom power, control and gas connections. Includes a 3/4-inch diameter liquid tight conduit fitting for high voltage power wires, (2) 1/2- inch diameter liquid tight conduits for thermostat wires and convenience outlet wires and 1/2-inch gas adapter fitting for gas piping. Provides for watertight seal.	036-072
CRBTMPWR002A01	Thru-the-bottom electrical connections and thru-the-curb (not thru the bottom) gas connections. Includes a 1-1/4-inch (32 mm) diameter liquid tight conduit fitting for high voltage power wires and (2) 1/2-inch (13 mm) diameter liquid tight conduit fittings for thermostat wires and convenience outlet wires. Includes a 3/4-inch (19 mm) inside pipe coupling and gas plate assembly for thru-the-curb connections. Provides for watertight seals.	090-150
CRBTMPWR004A01	Thru-the bottom power, control and gas connections. Includes a 1-1/4- inch diameter liquid tight conduit fitting for high voltage power wires, (2) 1/2-inch diameter liquid tight conduits for thermostat wires and convenience outlet wires and 3/4-inch gas adapter fitting for gas piping. Provides for watertight seal.	090-150
CRBTMPWR005A01	Thru-the bottom power, control and gas connections. Includes a 1-1/4- inch diameter liquid tight conduit fitting for high voltage power wires, (2) 1/2-inch diameter liquid tight conduits for thermostat wires and convenience outlet wires and 3/4-inch gas adapter fitting for gas piping, 4 cover plates, and gaskets for watertight seal.	180

<b>THROUGH-THE-BOTTOM/CURB POWER CONNECTION</b>		
CRBTMPWR006A00	Thru-the bottom power, control and gas connections. Includes a 1-1/2- inch diameter liquid tight conduit fitting for high voltage power wires, (2) 1/2-inch diameter liquid tight conduits for thermostat wires and convenience outlet wires and 3/4-inch gas adapter fitting for gas piping, 4 cover plates, and gaskets for watertight seal.	180
CRBTMPWR007A00	Thru-the bottom power, control and gas connections. Includes a 2-inch diameter liquid tight conduit fitting for high voltage power wires, (2) 1/2- inch diameter liquid tight conduits for thermostat wires and convenience outlet wires and 3/4-inch gas adapter fitting for gas piping, 4 cover plates, and gaskets for watertight seal	180

**NOTE:** Access to the bottom of the RTU is required to install a THRU-THE-BOTTOM Connection Kit. Recommend installing kit prior to installing RTU on roof curb.

<b>LP GAS CONVERSION KITS *</b>		
<b>Model Number</b>	<b>Description</b>	<b>Use With Model Size</b>
CRLPELEV001A00	Propane and Hi Altitude conversion kit. Contains spuds sizes 31, 32, 33, 35, and 36 (5 spuds/ size) and other necessary conversion parts. Use this kit to convert Natural Gas rooftops to Propane and/or high altitude applications.	036 – 150
CRLPELEV002A00	Propane and Hi Altitude conversion kit. Contains spuds sizes 37, 38, 39, 44, and 45 (5 spuds/size) and other necessary conversion parts. Use this kit to convert Natural Gas rooftops to Propane and/or high altitude applications.	036 – 150
CRLPELEV003A00	Propane and Hi Altitude conversion kit. Contains spuds sizes 46, 47, 48, 49, and 50 (5 spuds/size) and other necessary conversion parts. Use this kit to convert Natural Gas rooftops to Propane and/or high altitude applications.	036 – 150
CRLPELEV004A00	Propane and Hi Altitude conversion kit. Contains spuds sizes 51, 52, 53, 54, and 55 (5 spuds/size) and other necessary conversion parts. Use this kit to convert Natural Gas rooftops to Propane and/or high altitude applications.	036 – 150
CRLPELEV007A00	Propane and Hi Altitude conversion kit. Contains spuds sizes 36, 37, 38, and 39 (10 spuds/size) and other necessary conversion parts. Use this kit to convert Natural Gas rooftops to Propane and/or high altitude applications.	180
CRLPELEV008A00	Propane and Hi Altitude conversion kit. Contains spuds sizes 40, 41, 42, and 43 (10 spuds/size) and other necessary conversion parts. Use this kit to convert Natural Gas rooftops to Propane and/or high altitude applications.	180
CRLPELEV009A00	Propane and Hi Altitude conversion kit. Contains spuds sizes 51, 52, 53, 54, and 55 (10 spuds/size) and other necessary conversion parts. Use this kit to convert Natural Gas rooftops to Propane and/or high altitude applications.	180

\* See Appendix A, LP kit instructions, and service manual for more details.

<b>HEATING UPGRADE KITS</b>		
<b>Model Number</b>	<b>Description</b>	<b>Use With Model Size</b>
CRFLUEDS001A00	Flue Discharge Deflector -- Directs flue gas exhaust 90 degrees upward from current discharge. Designed to allow tighter distances between unit and combustible surfaces. 24 inch Height. AGA certified. <sup>1</sup>	036-150
CRFLUEHD001A01	Flue Exhaust Heat Shield -- Provides a sheet metal guard around the flue gas hood which prevents service personnel or small children from coming into contact with the flue hood. <sup>1</sup>	036-150
CRFLUEDS007A00	Flue Discharge Deflector -- Directs flue gas exhaust 90 degrees upward from current discharge. Designed to allow tighter distances between unit and combustible surfaces.	180

<sup>1</sup> CRFLUEDS001A00 and CRFLUEHD001A01 are mutually exclusive. Cannot install both on the same unit.

## ACCESSORIES – RGS036–180 (cont.)

CONTROL UPGRADE KITS		
Model Number	Description	Use With Model Size
CRDISKIT001A00	2 Speed VFD display kit – Provides the field capability to set up points and troubleshooting codes on the VFD controller. Kit includes display and cable. If preferred, kit can be used for any associated unit with VFD.	All 2 Speed VFD Controllers
NRTIMEGD001A00	Time Guard II -- Automatically prevents the compressor from restarting for at least 4 minutes and 45 seconds after shutdown of the compressor. Not required when a commercial thermostat has a minimum 5 min time delay between cooling cycles available (One required per unit)	All
DNWINSTR001A00	Winter Start Package - Contains time delay relay for timed bypass of low pressure switch on startup.(One required per refrigerant circuit) <sup>1</sup>	All
CRPHASE3001A02	Phase Monitor Control - Provides phase loss/phase reversal protection	All 3 Phase 208/230-3-60 460-3-60
CRPHASE3002A00	Phase Monitor Control - Provides phase loss/phase reversal protection	All 3 Phase 575v
CRSDTEST001A00	Remote keyed attenuator / test / reset station for use with factory installed smoke detectors. Includes power, alarm & trouble indicator lights.	All

<sup>1</sup> If mechanical cooling below 25 degrees ambient is necessary, consider additional low-ambient control measures (for example, economizer or motormaster)

LOW AMBIENT CONTROLS (SIZE 036–121) *		
Model Number	Description	Use With Model Size
CPLOWAMB001A00	Motormaster® II Low Ambient Control - Enables cooling system to operate down to 0° F (-18° C) by cycling condenser fan on and off. The control is activated by a temperature sensor. No motor change-out required. One required per unit.	All Sizes 208/230-1-60 208/230-3-60 460-3-60 **
HC40GE233 / 1171974 <sup>1</sup>	Motormaster I Compatible Condenser Fan Motor	All Sizes 208/230-1-60 208/230-3-60
HC40GE463 / 1171975 <sup>1</sup>	Motormaster I Compatible Condenser Fan Motor	All Sizes 460-3-60 575-3-60
32LT-900---301	Motormaster I Single-Phase Solid-State Variable Speed Motor Controller enables cooling down to -20° F by varying the speed on the condenser fan.	All Sizes 208/230-1-60 208/203-3-60
32LT-900---611	Motormaster I Single-Phase Solid-State Variable Speed Motor Controller enables cooling down to -20° F (-29° C) by varying the speed on the condenser fan.	All Sizes 460-3-60
HC91CL010 / 1171807 <sup>1</sup>	MFD 10	Refer to MotorMaster I usage table
HC93CA013 / 1175708 <sup>1</sup>	Dual MFD 10 + 10	Refer to MotorMaster I usage table
HC98JA048 / 1173702 <sup>1</sup>	Dual MFD 45 + 10	Refer to MotorMaster I usage table
HC98JA073 / 1177750 <sup>1</sup>	Dual MFD 70 + 10	Refer to MotorMaster I usage table
HC98JA083 / 1173703 <sup>1</sup>	Dual MFD 80 + 10	Refer to MotorMaster I usage table

<sup>1</sup> Available from FAST Parts.

\* See usage tables in kit instructions.

\*\* One DNWINSTR001A00 also required per refrigerant circuit.

Sizes 036-072 require one (1) Low Ambient Controller and one (1) compatible condenser fan motor for change-out.

Sizes 090-121 require one (1) Low Ambient Controller and one (2) compatible condenser fan motor for change-out.

LOW AMBIENT CONTROLS (SIZE 150 ONLY) *		
CRLOWAMB030A00	Motormaster V Low Ambient Kit. Mechanical cooling operation down to -20° F (- 29° C)	150 208/230-3-60
CRLOWAMB031A00	Motormaster V Low Ambient Kit. Mechanical cooling operation down to -20° F (- 29° C)	150 460-3-60
CRLOWAMB032A00	Motormaster V Low Ambient Kit. Mechanical cooling operation down to -20° F (- 29° C).	150 575-3-60

**NOTE:** Also requires two DNWINSTR001A00 Start packages (One per refrigerant circuit). No motor change is required on these specific models.

## ACCESSORIES – RGS036–180 (cont.)

LOW AMBIENT CONTROLS (SIZE 180 ONLY) *		
CRLOWAMB039A00	Motormaster I Low Ambient Kit. Mechanical cooling operation down to -20° F (- 29° C). Kit includes 3 motors, MotorMaster controller, wiring label, and required wire ties and connectors, CRWIN-STR001A00 also required (one per refrigerant circuit)	180 208/230-3-60
CRLOWAMB040A00	Motormaster I Low Ambient Kit. Mechanical cooling operation down to -20° F (- 29° C). Kit includes 3 motors, MotorMaster controller, wiring label, and required wire ties and connectors ) 575 Volt models also require CRTRXKIT002A00 plus CRWIN-STR001A00 also required (one per refrigerant circuit)	180 460-3-60 575-3-60
CRTRXKIT002A00	Motormaster® I Low Ambient Control - Transformer Kit. Must be used in conjunction with Low Ambient Controller if used on 575-3-60 volt models.	180 575-3-60

**Table 2 – AHRI COOLING RATING TABLE – Single Stage Cooling**

Unit RGS	Cooling Stages	Nom. Capacity (tons)	Net Cooling Capacity (MBH)	Total Power (KW)	SEER	EER	IEER WITH 1 SPEED INDOOR FAN MOTOR
036	1	3	34.6	3.1	13.0	11.00	N/A
048	1	4	45.0	4.0	13.0	11.00	N/A
060	1	5	59.0	5.5	13.0	10.75	N/A
072	1	6	70.0	6.4	N/A	11.00	11.2
091	1	7.5	88.0	8.0	N/A	11.00	11.2
101	1	8.5	97.0	8.8	N/A	11.00	11.2
121	1	10	117.0	10.6	N/A	11.00	11.2

**Table 3 – AHRI COOLING RATING TABLE – Two Stage Cooling**

UNIT RGS	COOLING STAGES	NOM. CAPACITY (TONS)	NET COOLING CAPACITY (MBH)	TOTAL POWER (KW)	SEER	EER	IEER WITH 1 SPEED INDOOR FAN MOTOR	IEER WITH 2 SPEED INDOOR FAN MOTOR
090	2	7.5	83.0	7.5	N/A	11.00	11.7	12.8
102	2	8.5	99.0	9.0	N/A	11.00	11.7	12.8
120	2	10	114.0	10.3	N/A	11.10	11.8	12.8
150	2	12.5	140.0	12.9	N/A	10.80	11.0	11.8
180	2	15	174.00	16.1	N/A	10.80	11.7	12.4

**LEGEND**

- AHRI – Air-Conditioning, Heating & Refrigeration Institute
- ASHRAE – American Society of Heating, Refrigerating and Air Conditioning, Inc.
- EER – Energy Efficiency Ratio
- IEER – Integrated Energy Efficiency Ratio
- SEER – Seasonal Energy Efficiency Ratio
- IPLV – Integrated Part Load Value

**NOTES:**

1. Rated and certified under AHRI Standard 210/240-06 or 340/360-04, as appropriate.
2. Ratings are based on:  
**Cooling Standard:** 80°F (27°C) db, 67°F (19°C) wb indoor air temp and 95°F (35°C) db outdoor air temp.  
**IPLV Standard:** 80°F (27°C) db, 67°F (19°C) wb indoor air temp and 80°F (27°C) db outdoor air temp.  
**IEER Standard:** Procedure described in AHRI Standard 340/360.
3. All RGS units comply with ASHRAE 90.1 2001, 2004 Energy Standard for minimum SEER and EER requirements.
4. RGS units comply with US Energy Policy Act (2005). To evaluate code compliance requirements, refer to state and local codes or visit the following website: <http://bcap-energy.org>.



OR



Use of the AHRI Certified TM Mark indicates a manufacturer's participation in the program. For verification of certification for individual products, go to [www.ahridirectory.org](http://www.ahridirectory.org).

**Table 4 – HEATING RATING TABLE – NATURAL GAS & LIQUID PROPANE**

UNIT RGS	GAS HEAT	AL & SS HEAT EXCHANGER		TEMP RISE (DEG F)	THERMAL EFFICIENCY (%)	AFUE (%)	
		INPUT / OUTPUT STAGE 1 (MBH)	INPUT / OUTPUT STAGE 2 (MBH)				
Single Phase	036	LOW	---	72 / 56	25 – 55	82%	79.1%
		MED	---	115 / 89	55 – 85	80%	78.5%
		HIGH	---	---	---	---	---
	048	LOW	---	72 / 56	25 – 55	82%	79.1%
		MED	---	115 / 90	35 – 65	81%	79%
		HIGH	---	150 / 117	50 – 80	80%	78.8%
	060	LOW	---	72 / 56	20 – 55	82%	79.1%
		MED	---	115 / 90	30 – 65	81%	79%
		HIGH	---	150 / 117	40 – 80	80%	78.8%
Three Phase	036	LOW	---	72 / 56	25 – 55	82%	N/A
		MED	82 / 66	115 / 89	55 – 85	80%	N/A
		HIGH	---	---	---	---	---
	048	LOW	---	72 / 56	25 – 55	82%	N/A
		MED	---	115 / 90	35 – 65	81%	N/A
		HIGH	120 / 96	150 / 117	50 – 80	80%	N/A
	060	LOW	---	72 / 56	20 – 55	82%	N/A
		MED	---	115 / 90	30 – 65	81%	N/A
		HIGH	120 / 96	150 / 117	40 – 80	80%	N/A
	072	LOW	---	72 / 59	15 – 55	82%	N/A
		MED	---	115 / 93	25 – 65	81%	N/A
		HIGH	120 / 96	150 / 120	35 – 80	80%	N/A
	090/091	LOW	---	125 / 103	20 – 50	82%	N/A
		MED	120 / 98	180 / 148	35 – 65	82%	N/A
		HIGH	180 / 147	224 / 184	45 – 75	82%	N/A
	101/102	LOW	---	125 / 103	20 – 50	82%	N/A
		MED	120 / 98	180 / 148	30 – 65	82%	N/A
		HIGH	180 / 147	224 / 184	40 – 75	82%	N/A
	120/121	LOW	120 / 98	180 / 148	25 – 65	82%	N/A
		MED	180 / 147	224 / 184	30 – 65	82%	N/A
		HIGH	200 / 160	250 / 205	35 – 70	80%	N/A
150	LOW	120 / 98	180 / 148	20 – 65	82%	N/A	
	MED	180 / 147	224 / 184	25 – 65	82%	N/A	
	HIGH	200 / 160	250 / 205	25 – 70	80%	N/A	
180	LOW	144 / 118	180 / 146	15 – 55	81%	N/A	
	MED	192 / 156	240 / 195	20 – 60	81%	N/A	
	HIGH	280 / 224	350 / 280	35 – 65	80%	N/A	

**NOTE:**

1. Heat ratings are for natural gas heat exchangers operated at or below 2000 ft. For information on LP or altitudes above 2000 ft (610m), see the Application Data section of this book. Accessory LP/High Altitude kits are also available.
2. In the USA the input rating for altitudes above 2000 ft (610m) must be derated by 4% for each 1000 ft (305 m) above sea level. In Canada, the input rating must be derated by 10% for altitudes of 2000 ft (610 m) to 4500 ft (1372 m) above sea level.

**Table 5 – HEATING RATING TABLE – LOW NO<sub>x</sub><sup>1</sup>**

UNIT	GAS HEAT	LOW NO <sub>x</sub> HEAT EXCHANGER		TEMP RISE (DEG F)	THERMAL EFFICIENCY (%)	AFUE (%)	
		INPUT / OUTPUT STAGE 1 (MBH)	INPUT / OUTPUT STAGE 2 (MBH)				
Single Phase	036	LOW	---	60 / 47	20 – 50	81%	80.6%
		MED	---	90 / 72	30 – 60	81%	80.6%
		HIGH	---	---	---	---	---
	048	LOW	---	60 / 47	20 – 50	81%	80.6%
		MED	---	90 / 72	30 – 60	81%	80.6%
		HIGH	---	120 / 97	40 – 70	81%	81.5%
060	LOW	---	60 / 47	15 – 50	81%	80.6%	
	MED	---	90 / 72	25 – 60	80%	80.6%	
	HIGH	---	120 / 97	35 – 70	80%	81.5%	
Three Phase	036	LOW	---	60 / 47	20 – 50	81%	N/A
		MED	---	90 / 72	30 – 60	81%	N/A
		HIGH	---	---	---	---	---
	048	LOW	---	60 / 47	20 – 50	81%	N/A
		MED	---	90 / 72	30 – 60	81%	N/A
		HIGH	---	120 / 97	40 – 70	81%	N/A
	00	LOW	---	60 / 47	15 – 50	81%	N/A
		MED	---	90 / 72	25 – 60	80%	N/A
		HIGH	---	120 / 97	35 – 70	80%	N/A

**NOTE:**

1. Units meet the Southern California Air Quality Management (SCAQM) Counsel Low-NO<sub>x</sub> emissions requirement of 40 nanograms per joule or less.
2. See Appendix A on page 87 for ALTITUDE COMPENSATION TABLES.

**Table 6 – SOUND PERFORMANCE TABLE**

UNIT	COOLING STAGES	OUTDOOR SOUND (dB)								
		A-WEIGHTED	63	125	250	500	1000	2000	4000	8000
036	1	80	90.6	80.9	80.2	76	74.6	71.3	68.5	63.9
048	1	81	90.9	84.6	79.5	77.9	76.5	71.1	66.9	62.5
060	1	78	84.0	82.2	76.3	74.8	72.5	68.8	65.6	61.8
072	1	78	88.8	81.8	76.9	74.4	73.3	69.8	66.3	62.7
091	1	82	90.1	82.6	81.0	79.4	77.0	73.0	70.4	66.7
090	2	82	85.8	84.3	80.5	78.7	76.4	72.7	68.3	65.1
101	1	83	91.2	86.4	81.9	81.0	78.3	73.9	71.4	67.3
102	2	82	88.6	85.0	81.6	79.5	77.4	74.1	71.0	66.3
121	1	82	88.6	85.0	81.6	79.5	77.4	74.1	71.0	66.3
120	2	82	89.0	83.1	80.5	78.5	75.5	71.6	69.6	69.3
150	2	87	87.0	85.2	84.6	84.9	82.2	78.4	75.3	72.9
180	2	87	87.0	85.2	84.6	84.9	82.2	78.4	75.3	72.9

**LEGEND**

dB – Decibel



Use of the AHRI Certified TM Mark indicates a manufacturer's participation in the program. For verification of certification for individual products, go to [www.ahridirectory.org](http://www.ahridirectory.org)

**NOTES:**

1. Outdoor sound data is measure in accordance with AHRI standard 270-95.
2. Measurements are expressed in terms of sound power. Do not compare these values to sound pressure values because sound pressure depends on specific environmental factors which normally do not match individual applications. Sound power values are independent of the environment and therefore more accurate.
3. A-weighted sound ratings filter out very high and very low frequencies, to better approximate the response of "average" human ear. A-weighted measurements are taken in accordance with AHRI standard 270-95.

**Table 7 – MINIMUM – MAXIMUM AIRFLOW RATINGS – NATURAL GAS & LIQUID PROPANE**

UNIT RGS	HEAT LEVEL	COOLING		AL HX HEATING	
		Minimum	Maximum	Minimum	Maximum
036	LOW	900	1500	990	2190
	MED			1000	1550
	HIGH			-	-
048	LOW	1200	2000	990	2190
	MED			1330	2460
	HIGH			1390	2220
060	LOW	1500	2500	990	2730
	MED			1330	2880
	HIGH			1390	2780
072	LOW	1800	3000	990	3640
	MED			1330	3450
	HIGH			1390	3170
090/091	LOW	2250	3750	1900	4750
	MED			2100	3900
	HIGH			2270	3780
101/102	LOW	2550	4250	1900	4750
	MED			2100	4560
	HIGH			2270	4250
120/121	LOW	3000	5000	2100	5470
	MED			2620	5670
	HIGH			2650	5290
150	LOW	3600	6000	2100	6830
	MED			2620	6800
	HIGH			2650	7410
180	LOW	4500	7500	2450	7500
	MED			3000	6750
	HIGH			3990	7200



**Table 8 – PHYSICAL DATA (COOLING) 3 – 6 TONS**

		<b>RGS036</b>	<b>RGS048</b>	<b>RGS060</b>	<b>RGS072</b>
<b>Refrigeration System</b>					
# Circuits / # Comp. / Type		1 / 1 / Scroll	1 / 1 / Scroll	1 / 1 / Scroll	1 / 1 / Scroll
R-410a charge A/B (lbs – oz)		5 – 10	8 – 8	10 – 11	14 – 2
Hot Gas Reheat R-410a charge A/B (lbs – oz)		8 – 11	14 – 13	16 – 0	22 – 5
oil A/B (oz)		25	42	42	56
Metering device		Accutrol	Accutrol	Accutrol	Accutrol
Hot Gas Reheat Metering device		Accutrol + TXV	Accutrol + TXV	Accutrol + TXV	Accutrol + TXV
High–press. Trip / Reset (psig)		630 / 505	630 / 505	630 / 505	630 / 505
Low–press. Trip / Reset (psig)		54 / 117	54 / 117	54 / 117	54 / 117
<b>Evap. Coil</b>					
Material		Cu / Al	Cu / Al	Cu / Al	Cu / Al
Coil type		3/8" RTPF	3/8" RTPF	3/8" RTPF	3/8" RTPF
Rows / FPI		2 / 15	2 / 15	4 / 15	4 / 15
total face area (ft <sup>2</sup> )		5.5	5.5	5.5	7.3
Condensate drain conn. size		3/4"	3/4"	3/4"	3/4"
<b>Hot Gas Reheat Coil</b>					
Material		Cu / Al	Cu / Al	Cu / Al	Cu / Al
Coil type		3/8" RTPF	3/8" RTPF	3/8" RTPF	3/8" RTPF
Rows / FPI		1 / 17	2 / 17	2 / 17	2 / 17
total face area (ft <sup>2</sup> )		3.9	3.9	3.9	5.2
<b>Evap. Fan and Motor</b>					
Standard Static 1 phase	Motor Qty / Drive type	1 / Belt	1 / Belt	1 / Belt	n/a / Belt
	Max BHP	1.2	1.2	1.2	---
	RPM range	560–854	560–854	770–1175	---
	motor frame size	48	48	48	---
	Fan Qty / Type	1 / Centrifugal	1 / Centrifugal	1 / Centrifugal	n/a / Centrifugal
Fan Diameter (in)	10 x 10	10 x 10	10 x 10	---	
Medium Static 1 phase	Motor Qty / Drive type	1 / Belt	1 / Belt	1 / Belt	n/a / Belt
	Max BHP	1.2	1.2	1.5	---
	RPM range	770–1175	770–1175	1035–1466	---
	motor frame size	48	48	56	---
	Fan Qty / Type	1 / Centrifugal	1 / Centrifugal	1 / Centrifugal	n/a / Centrifugal
Fan Diameter (in)	10 x 10	10 x 10	10 x 10	---	
Standard Static 3 phase	Motor Qty / Drive type	1 / Belt	1 / Belt	1 / Belt	1 / Belt
	Max BHP	1.7	1.7	1.7	2.4
	RPM range	560–854	560–854	770–1175	1073–1457
	motor frame size	48	48	48	56
	Fan Qty / Type	1 / Centrifugal	1 / Centrifugal	1 / Centrifugal	1 / Centrifugal
Fan Diameter (in)	10 x 10	10 x 10	10 x 10	10 x 10	
Medium Static 3 phase	Motor Qty / Drive type	1 / Belt	1 / Belt	1 / Belt	1 / Belt
	Max BHP	1.7	1.7	2.4	2.9
	RPM range	770–1175	770–1175	1035–1466	1173–1518
	motor frame size	48	48	56	56
	Fan Qty / Type	1 / Centrifugal	1 / Centrifugal	1 / Centrifugal	1 / Centrifugal
Fan Diameter (in)	10 x 10	10 x 10	10 x 10	10 x 10	
High Static 3 phase	Motor Qty / Drive type	1 / Belt	1 / Belt	1 / Belt	1 / Belt
	Max BHP	2.4	2.4	2.9	3.7
	RPM range	1035–1466	1035–1466	1303–1687	1474–1788
	motor frame size	56	56	56	56
	Fan Qty / Type	1 / Centrifugal	1 / Centrifugal	1 / Centrifugal	1 / Centrifugal
Fan Diameter (in)	10 x 10	10 x 10	10 x 10	10 x 10	
<b>Cond. Coil</b>					
Material		Cu / Al	Cu / Al	Cu / Al	Cu / Al
Coil type		3/8" RTPF	3/8" RTPF	3/8" RTPF	3/8" RTPF
Rows / FPI		1 / 17	2 / 17	2 / 17	2 / 17
total face area (ft <sup>2</sup> )		14.6	16.5	16.5	21.3
<b>Cond. Fan / Motor</b>					
Qty / Motor drive type		1 / direct	1 / direct	1 / direct	1 / direct
Motor HP / RPM		1/4 / 1100	1/4 / 1100	1/4 / 1100	1/4 / 1100
Fan diameter (in)		22	22	22	22
<b>Filters</b>					
RA Filter # / size (in)		2 / 16 x 25 x 2	2 / 16 x 25 x 2	2 / 16 x 25 x 2	4 / 16 x 16 x 2
OA inlet screen # / size (in)		1 / 20 x 24 x 1	1 / 20 x 24 x 1	1 / 20 x 24 x 1	1 / 20 x 24 x 1

\* RTPF – Round Tube Plate Fin Coil Design

**Table 9 – PHYSICAL DATA (HEATING) 3 – 6 TONS**

		<b>RGS036</b>	<b>RGS048</b>	<b>RGS060</b>	<b>RGS072</b>
<b>Gas Connection</b>					
	# of Gas Valves	1	1	1	1
	Nat. gas supply line press (in. w.g.) / (PSIG)	4 – 13 / 0.18 – 0.47	4 – 13 / 0.18 – 0.47	4 – 13 / 0.18 – 0.47	4 – 13 / 0.18 – 0.47
	LP supply line press (in. w.g.) / (PSIG)	11 – 13 / 0.40 – 0.47	11 – 13 / 0.40 – 0.47	11 – 13 / 0.40 – 0.47	11 – 13 / 0.40 – 0.47
<b>Heat Anticipator setting (Amps)</b>					
	1st stage	0.14	0.14	0.14	0.14
	2nd stage	0.14	0.14	0.14	0.14
<b>Natural Gas Heat</b>					
<b>L</b> <b>O</b> <b>W</b>	# of stages / # of burners (total)	1 / 2	1 / 2	1 / 2	1 / 2
	Connection Size	1/2" NPT	1/2" NPT	1/2" NPT	1/2" NPT
	Rollout switch opens / closes	195 / 115	195 / 115	195 / 115	195 / 115
	Temperature Rise	25 – 55	25 – 55	20 – 55	15 – 55
<b>M</b> <b>E</b> <b>D</b>	# of stages / # of burners (total)	1 or 2 / 3	1 / 3	1 / 3	1 / 3
	Connection Size	1/2" NPT	1/2" NPT	1/2" NPT	1/2" NPT
	Rollout switch opens / closes	195 / 115	195 / 115	195 / 115	195 / 115
	Temperature Rise	55 – 85	35 – 65	30 – 65	25 – 65
<b>H</b> <b>I</b> <b>G</b> <b>H</b>	# of stages / # of burners (total)	---	1 or 2 / 3	1 or 2 / 3	2 / 3
	Connection Size	---	1/2" NPT	1/2" NPT	1/2" NPT
	Rollout switch opens / closes	---	195 / 115	195 / 115	195 / 115
	Temperature Rise	---	50 – 80	40 – 80	35 – 80
<b>Liquid Propane Heat</b>					
<b>L</b> <b>O</b> <b>W</b>	# of stages / # of burners (total)	1 / 2	1 / 2	1 / 2	1 / 2
	Connection Size	1/2" NPT	1/2" NPT	1/2" NPT	1/2" NPT
	Rollout switch opens / closes	195 / 115	195 / 115	195 / 115	195 / 115
	Temperature Rise	25 – 55	25 – 55	20 – 55	15 – 55
<b>M</b> <b>E</b> <b>D</b>	# of stages / # of burners (total)	1 or 2 / 3	1 / 3	1 / 3	1 / 3
	Connection Size	1/2" NPT	1/2" NPT	1/2" NPT	1/2" NPT
	Rollout switch opens / closes	195 / 115	195 / 115	195 / 115	195 / 115
	Temperature Rise	55 – 85	35 – 65	30 – 65	25 – 65
<b>H</b> <b>I</b> <b>G</b> <b>H</b>	# of stages / # of burners (total)	---	1 or 2 / 3	1 or 2 / 3	2 / 3
	Connection Size	---	1/2" NPT	1/2" NPT	1/2" NPT
	Rollout switch opens / closes	---	195 / 115	195 / 115	195 / 115
	Temperature Rise	---	50 – 80	40 – 80	35 – 80
<b>Low NOx Gas Heat</b>					
<b>L</b> <b>O</b> <b>W</b>	# of stages / # of burners (total)	1 / 2	1 / 2	1 / 2	---
	Connection Size	1/2" NPT	1/2" NPT	1/2" NPT	---
	Rollout switch opens / closes	195 / 115	195 / 115	195 / 115	---
	Temperature Rise	20 – 50	20 – 50	15 – 50	---
<b>M</b> <b>E</b> <b>D</b>	# of stages / # of burners (total)	1 / 3	1 / 3	1 / 3	---
	Connection Size	1/2" NPT	1/2" NPT	1/2" NPT	---
	Rollout switch opens / closes	195 / 115	195 / 115	195 / 115	---
	Temperature Rise	30 – 60	30 – 60	25 – 60	---
<b>H</b> <b>I</b> <b>G</b> <b>H</b>	# of stages / # of burners (total)	---	1 / 3	1 / 3	---
	Connection Size	---	1/2" NPT	1/2" NPT	---
	Rollout switch opens / closes	---	195 / 115	195 / 115	---
	Temperature Rise	---	40 – 70	35 – 70	---

**Table 10 – PHYSICAL DATA (COOLING) 7.5 – 8.5 TONS**

		<b>RGS091</b>	<b>RGS090</b>	<b>RGS101</b>	<b>RGS102</b>
<b>Refrigeration System</b>					
	# Circuits / # Comp. / Type	1 / 1 / Scroll	2 / 2 / Scroll	1 / 1 / Scroll	2 / 2 / Scroll
	RTPF models R-410a charge A/B (lbs – oz)	13 – 12	8 – 5 / 8 – 2	15 – 4	10 – 5 / 10 – 12
	Alternate Hot Gas Reheat R-410a charge A/B (lbs – oz)	---	13 – 3 / 13 – 3	---	16 – 13 / 16 – 13
	oil A/B (oz)	60	42 / 42	85	42 / 42
	Metering device	Accutrol	Accutrol	Accutrol	Accutrol
	Alternate Hot Gas Reheat Metering device	---	Accutrol + TXV	---	Accutrol + TXV
	High–press. Trip / Reset (psig)	630 / 505	630 / 505	630 / 505	630 / 505
	Low–press. Trip / Reset (psig)	54 / 117	54 / 117	54 / 117	54 / 117
	Condensate drain conn. size	3/4"	3/4"	3/4"	3/4"
<b>Evap. Coil</b>					
	Material	Cu / Al	Cu / Al	Cu / Al	Cu / Al
	Coil type	3/8" RTPF	3/8" RTPF	3/8" RTPF	3/8" RTPF
	Rows / FPI	3 / 15	3 / 15	3 / 15	3 / 15
	total face area (ft <sup>2</sup> )	8.9	8.9	11.1	11.1
<b>Evap. Fan and Motor</b>					
Standard Static 3 phase	Motor Qty / Drive type	1 / Belt	1 / Belt	1 / Belt	1 / Belt
	Max BHP	1.7	1.7	1.7	1.7
	RPM range	489–747	489–747	518–733	518–733
	motor frame size	56	56	56	56
	Fan Qty / Type	1 / Centrifugal	1 / Centrifugal	1 / Centrifugal	1 / Centrifugal
	Fan Diameter (in)	15 x 15	15 x 15	15 x 15	15 x 15
Medium Static 3 phase	Motor Qty / Drive type	1 / Belt	1 / Belt	1 / Belt	1 / Belt
	Max BHP	2.9 **	2.9 **	2.4	2.4
	RPM range	733–949	733–949	690–936	690–936
	motor frame size	56	56	56	56
	Fan Qty / Type	1 / Centrifugal	1 / Centrifugal	1 / Centrifugal	1 / Centrifugal
	Fan Diameter (in)	15 x 15	15 x 15	15 x 15	15 x 15
High Static 3 phase	Motor Qty / Drive type	1 / Belt	1 / Belt	1 / Belt	1 / Belt
	Max BHP	4.7	4.7	3.7	3.7
	RPM range	909–1102	909–1102	838–1084	838–1084
	motor frame size	14	14	56	56
	Fan Qty / Type	1 / Centrifugal	1 / Centrifugal	1 / Centrifugal	1 / Centrifugal
	Fan Diameter (in)	15 x 15	15 x 15	15 x 15	15 x 15
<b>Cond. Coil</b>					
	Material	Cu / Al	Cu / Al	Cu / Al	Cu / Al
	Coil type	3/8" RTPF	3/8" RTPF	3/8" RTPF	3/8" RTPF
	Rows / FPI	2 / 17	2 / 17	2 / 17	2 / 17
	total face area (ft <sup>2</sup> )	20.5	20.5	21.4	25.1
<b>Cond. Fan / Motor</b>					
	Qty / Motor drive type	2 / direct	2 / direct	2 / direct	2 / direct
	Motor HP / RPM	1/4 / 1100	1/4 / 1100	1/4 / 1100	1/4 / 1100
	Fan diameter (in)	22	22	22	22
<b>Filters</b>					
	RA Filter # / size (in)	4 / 16 x 20 x 2	4 / 16 x 20 x 2	4 / 20 x 20 x 2	4 / 20 x 20 x 2
	OA inlet screen # / size (in)	1 / 20 x 24 x 1	1 / 20 x 24 x 1	1 / 20 x 24 x 1	1 / 20 x 24 x 1

\* RTPF – Round Tube Plate Fin Coil Design

\*\* 575V motor utilizes 3.7 BHP

**Table 11 – PHYSICAL DATA (COOLING) 10 – 15 TONS**

		RGS121	RGS120	RGS150	RGS180
<b>Refrigeration System</b>					
# Circuits / # Comp. / Type		1 / 1 / Scroll	2 / 2 / Scroll	2 / 2 / Scroll	2 / 2 / Scroll
RTPF models R-410a charge A/B (lbs – oz)		20 – 0	10 – 5 / 10 – 3	11 – 0 / 11 – 6	15–14/16–12
Alternate Gas Reheat R-410a charge A/B (lbs – oz)		---	16 – 10 / 16 – 0	17 – 10 / 18 – 3	17 – 10 / 18 – 3
oil A/B (oz)		110	42 / 42	56/56	56/56
Metering device		Accutrol	Accutrol	Accutrol	Accutrol
Alternate Gas Reheat Metering device		---	Accutrol + TXV	Accutrol + TXV	Accutrol + TXV
High–press. Trip / Reset (psig)		630 / 505	630 / 505	630 / 505	630 / 505
Low–press. Trip / Reset (psig)		54 / 117	54 / 117	54 / 117	54 / 117
<b>Evap. Coil</b>					
Material		Cu / Al	Cu / Al	Cu / Al	Cu / Al
Coil type		3/8" RTPF	3/8" RTPF	3/8" RTPF	3/8" RTPF
Rows / FPI		4 / 15	4 / 15	4 / 15	3 / 15
total face area (ft <sup>2</sup> )		11.1	11.1	11.1	17.5
Condensate drain conn. size		3/4"	3/4"	3/4"	3/4"
<b>Perfect Humidity Coil</b>					
Material			Cu / Al	Cu / Al	
Coil type			3/8" RTPF	3/8" RTPF	
Rows / FPI			2 / 17	2 / 17	
total face area (ft <sup>2</sup> )			8.4	8.4	
<b>Evap. Fan and Motor</b>					
<div style="border: 1px solid black; padding: 5px; width: fit-content;">                     Standard Static 3 phase                 </div>	Motor Qty / Drive type	1 / Belt	1 / Belt	1 / Belt	1 / Belt
	Max BHP	2.4	2.4	2.9 **	2.9 **
	RPM range	591–838	591–838	652–843	507–676
	motor frame size	56	56	56	56Y
	Fan Qty / Type	1 / Centrifugal	1 / Centrifugal	1 / Centrifugal	1 / Centrifugal
	Fan Diameter (in)	15 x 15	15 x 15	15 x 15	18 x 18
<div style="border: 1px solid black; padding: 5px; width: fit-content;">                     Medium Static 3 phase                 </div>	Motor Qty / Drive type	1 / Belt	1 / Belt	1 / Belt	1 / Belt
	Max BHP	3.7	3.7	3.7	3.7
	RPM range	838–1084	838–1084	838–1084	627–851
	motor frame size	56	56	56	56HZ
	Fan Qty / Type	1 / Centrifugal	1 / Centrifugal	1 / Centrifugal	1 / Centrifugal
	Fan Diameter (in)	15 x 15	15 x 15	15 x 15	18 x 18
<div style="border: 1px solid black; padding: 5px; width: fit-content;">                     High Static 3 phase                 </div>	Motor Qty / Drive type	1 / Belt	1 / Belt	1 / Belt	1 / Belt
	Max BHP	4.7	4.7	4.7	6.1
	RPM range	1022–1240	1022–1240	1022–1240	776–955
	motor frame size	14	14	14	S184T
	Fan Qty / Type	1 / Centrifugal	1 / Centrifugal	1 / Centrifugal	1 / Centrifugal
	Fan Diameter (in)	15 x 15	15 x 15	15 x 15	18 x 18
<b>Cond. Coil</b>					
Material		Cu / Al	Cu / Al	Cu / Al	Cu / Al
Coil type		3/8" RTPF	3/8" RTPF	3/8" RTPF	3/8" RTPF
Rows / FPI		2 / 17	2 / 17	3 / 17	2/17
total face area (ft <sup>2</sup> )		25.1	25.1	25.1	2 @ 23.1
<b>Cond. Fan / Motor</b>					
Qty / Motor drive type		2 / direct	2 / direct	1 / direct	3 / direct
Motor HP / RPM		1/4 / 1100	1/4 / 1100	1 / 1175	1/4 / 1100
Fan diameter (in)		22	22	30	22
<b>Filters</b>					
RA Filter # / size (in)		4 / 20 x 20 x 2	4 / 20 x 20 x 2	4 / 20 x 20 x 2	6 / 18 x 24 x 2
OA inlet screen # / size (in)		1 / 20 x 24 x 1	1 / 20 x 24 x 1	1 / 20 x 24 x 1	Vert 2 / 24 x 27 x 1 Hz 1 / 30 x 39 x 1



\*\* 575V motor utilizes 3.7 BHP

**Table 12 – PHYSICAL DATA (HEATING) 7.5 – 15 TONS**

		RGS090/091	RGS101/102	RGS120/121	RGS150	RGS180
<b>Gas Connection</b>						
	# of Gas Valves	1				
	Nat. gas supply line press (in. w.g.)/(PSIG)	5 –13 / 0.18 – 0.47				
	Propane supply line press (in. w.g.)/(PSIG)	11 –13 / 0.40 – 0.47				
<b>Heat Anticipator Setting (Amps)</b>						
	1st stage	0.14	0.14	0.14	0.14	0.14
	2nd stage	0.14	0.14	0.14	0.14	0.14
<b>Natural Gas</b>						
LOW	# of stages / # of burners (total)			2 / 4	2 / 4	2 / 6
	Connection size	1/2" NPT	1/2" NPT	3/4" NPT	3/4" NPT	3/4" NPT
	Rollout switch opens / closes	195 / 115	195 / 115	195 / 115	195 / 115	225 / 145
	Temperature rise range (F)	20 – 50	20 – 50	25 – 65	25 – 65	20 – 55
MED	# of stages / # of burners (total)	2 / 4	2 / 4	2 / 5	2 / 5	2 / 8
	Connection size	3/4" NPT	3/4" NPT	3/4" NPT	3/4" NPT	3/4" NPT
	Rollout switch opens / closes	195 / 115	195 / 115	195 / 115	195 / 115	225 / 145
	Temperature rise range (F)	35 – 65	35 – 65	30 – 65	30 – 65	25 – 60
HIGH	# of stages / # of burners (total)	2 / 5	2 / 5	2 / 5	2 / 5	2 / 10
	Connection size	3/4" NPT	3/4" NPT	3/4" NPT	3/4" NPT	3/4" NPT
	Rollout switch opens / closes	195 / 115	195 / 115	195 / 115	195 / 115	225 / 145
	Temperature rise range (F)	45 – 75	45 – 75	35 – 70	35 – 70	35 – 65
<b>Propane Heat</b>						
LOW	# of stages / # of burners (total)	1 / 3	1 / 3	2 / 4	2 / 4	2 / 6
	Connection size	1/2" NPT	1/2" NPT	3/4" NPT	3/4" NPT	3/4" NPT
	Rollout switch opens / closes	195 / 115	195 / 115	195 / 115	195 / 115	225 / 145
	Temperature rise range (F)	20 – 50	20 – 50	25 – 65	25 – 65	20 – 55
MED	# of stages / # of burners (total)	2 / 4	2 / 4	2 / 5	2 / 5	2 / 8
	Connection size	3/4" NPT	3/4" NPT	3/4" NPT	3/4" NPT	3/4" NPT
	Rollout switch opens / closes	195 / 115	195 / 115	195 / 115	195 / 115	225 / 145
	Temperature rise range (F)	35 – 65	35 – 65	30 – 65	30 – 65	25 – 60
HIGH	# of stages / # of burners (total)	2 / 5	2 / 5	2 / 5	2 / 5	2 / 10
	Connection size	3/4" NPT	3/4" NPT	3/4" NPT	3/4" NPT	3/4" NPT
	Rollout switch opens / closes	195 / 115	195 / 115	195 / 115	195 / 115	225 / 145
	Temperature rise range (F)	45 – 75	45 – 75	35 – 70	35 – 70	35 – 65

# BASE UNIT DIMENSIONS – RGS036–072

NOTES:

1. DIMENSIONS ARE IN INCHES. DIMENSIONS IN [ ] ARE IN MILLIMETERS.
2.  CENTER OF GRAVITY
3.  DIRECTION OF AIR FLOW

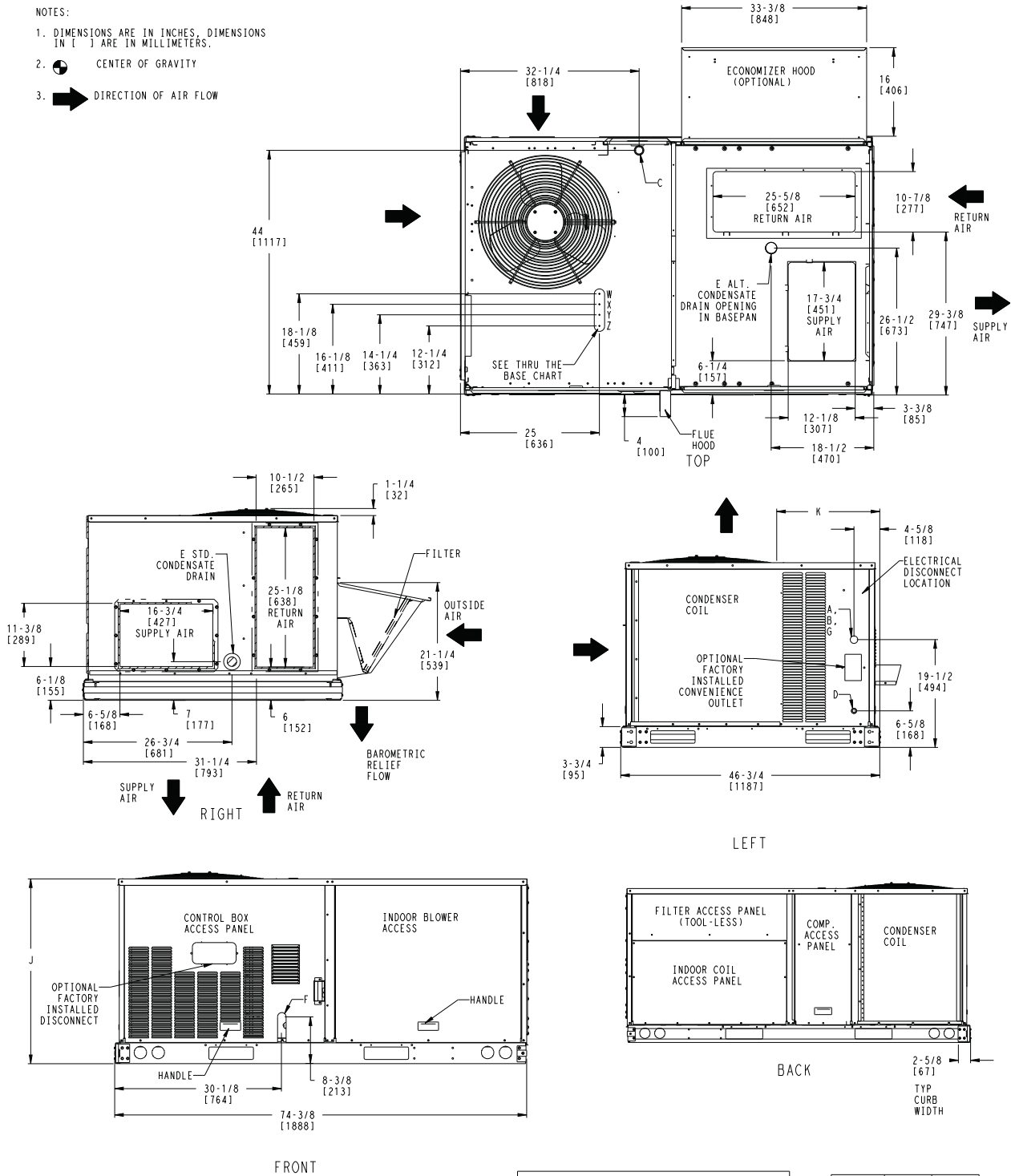

CONNECTION SIZES	
A	1 3/8" [35] DIA FIELD POWER SUPPLY HOLE
B	2" [50] DIA POWER SUPPLY KNOCKOUT
C	1 3/4" [51] DIA GAUGE ACCESS PLUG
D	7/8" [22] DIA FIELD CONTROL WIRING HOLE
E	3/4" -14 NPT CONDENSATE DRAIN
F	1/2" -14 NPT GAS CONNECTION
G	2 1/2" [64] DIA POWER SUPPLY KNOCK-OUT

THRU-THE-BASE CHART THESE HOLES REQUIRED FOR USE CRBTMPWRO01A01, 003A01			
	THREADED CONDUIT SIZE	WIRE USE	REQ'D HOLE SIZES (MAX.)
W	1/2"	ACC.	7/8" [22.2]
X	1/2"	24V	7/8" [22.2]
Y *	3/4" (001,003)	POWER	1 1/8" [28.4]
Z **	(003) 1/2" FPT	GAS	1 3/16" [30.0]
FOR "THRU-THE-BASEPAN" FACTORY OPTION, FITTINGS FOR ONLY X, Y, & Z ARE PROVIDED			
* SELECT EITHER 3/4" OR 1/2" FOR POWER, DEPENDING ON WIRE SIZE			
** (001) PROVIDES 3/4" FPT THRU CURB FLANGE & FITTING.			

UNIT	J	K
096	33 3/8 [847]	18 5/8 [472]
048	33 3/8 [847]	14 7/8 [377]
060	33 3/8 [847]	14 7/8 [377]
070	41 3/8 [1051]	14 7/8 [377]

## WEIGHT & CLEARANCE DIMENSIONS – RGS036–072 (cont.)

UNIT	BASE UNIT WEIGHT		Corner Weight A		Corner Weight B		Corner Weight C		Corner Weight D		Center of Gravity In [mm]		
	LBS	KG	LBS	KG	LBS	KG	LBS	KG	LBS	KG	X	Y	Z
RGS036	483	219	111	50	125	57	131	59	116	53	39 [991]	23 [584]	16–3/8 [416]
RGS048	537	244	124	56	139	63	145	66	129	59	39 [991]	23 [584]	17 [432]
RGS060	569	258	131	59	147	67	154	70	137	62	39 [991]	23 [584]	17–1/4 [438]
RGS072	652	296	150	68	169	76	176	80	157	71	39 [991]	23 [584]	20–1/8 [511]

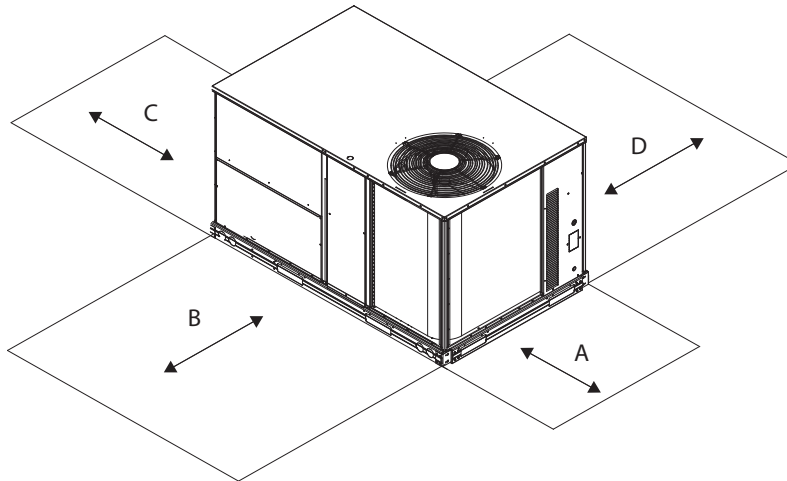
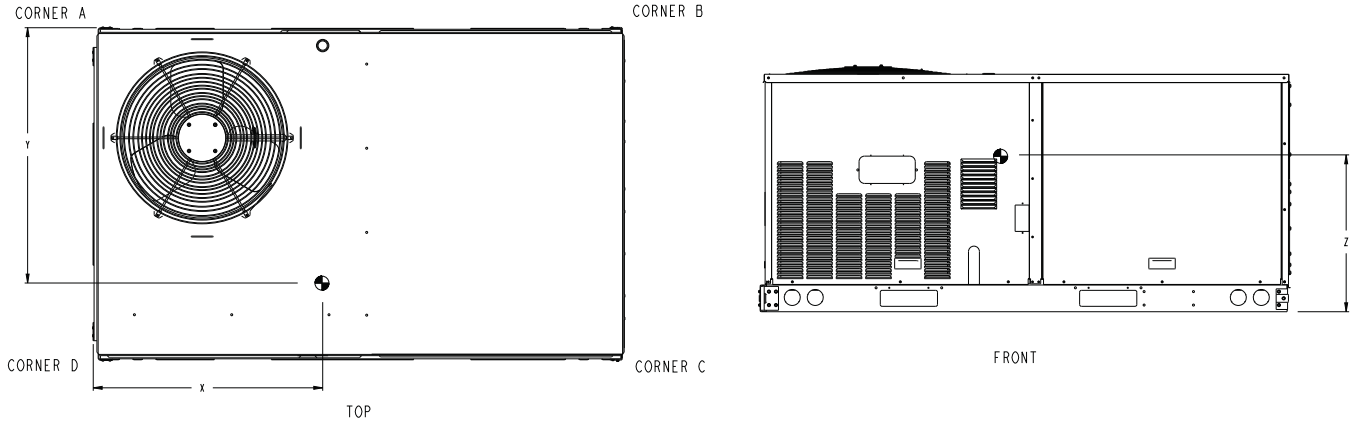

A10485A

C08337

UNIT CLEARANCES		
LOC	DIMENSION	CONDITION
A	48" (1219 mm) 18" (457 mm) 18" (457 mm) 12" (305 mm)	Unit disconnect is mounted on panel No disconnect, convenience outlet option Recommended service clearance Minimum clearance
B	42" (1067 mm) 36" (914 mm) Special	Surface behind servicer is grounded (e.g., metal, masonry wall) Surface behind servicer is electrically non-conductive (e.g., wood, fiberglass) Check for sources of flue products within 10-ft of unit fresh air intake hood
C	36" (914 mm) 18" (457 mm)	Side condensate drain is used Minimum clearance
D	48" (1219 mm) 42" (1067 mm) 36" (914 mm) Special	No flue discharge accessory installed, surface is combustible material Surface behind servicer is grounded (e.g., metal, masonry wall, another unit) Surface behind servicer is electrically non-conductive (e.g., wood, fiberglass) Check for adjacent units or building fresh air intakes within 10-ft of this unit's flue outlet

**NOTE:** Unit not designed to have overhead obstruction. Contact Application Engineering for guidance on any application planning overhead obstruction or vertical clearances.

# ROOF CURB DETAILS - RGS036-072

ROOF CURB ACCESSORY #	A
CRRCURB001A01	14" [356]
CRRCURB002A01	24" [610]

- NOTES:
1. ROOF CURB ACCESSORY IS SHIPPED DISASSEMBLED.
  2. INSULATED PANELS 254 (1" THK POLYURETHANE FOAM, 44.5 (1-3/4)"# DENSITY, 44.5 (1-3/4)"# DENSITY).
  3. ROOF CURB IS MADE OF GALVALUME METERS.
  4. ROOF CURB IS MADE OF GALVALUME METERS.
  5. ATTACH DUCTWORK TO CURB (FLANGES OF DUCT REST ON CURB).
  6. SERVICE CLEARANCE 4 FEET ON EACH SIDE.
  7.  DIRECTION OF AIR FLOW.
  8. CONNECTOR PACKAGE CRBTMPWR001A01 IS FOR THRU-THE-CURB GAS TYPE PACKAGE CRBTMPWR003A01 IS FOR THRU-THE-BOTTOM TYPE GAS CONNECTIONS.

CONNECTOR PKG. ACC.	GAS CONNECTION TYPE	GAS FITTING	POWER WIRING FITTING	CONTROL WIRING FITTING	ACCESSORY CONVENIENCE OUTLET WIRING CONNECTOR
CRBTMPWR001A01	THRU THE CURB	3/4" [19] NPT	3/4" [19] NPT	1/2" [12.7] NPT	1/2" [12.7] NPT
CRBTMPWR003A01	THRU THE BOTTOM	1/2" [12.7] NPT			

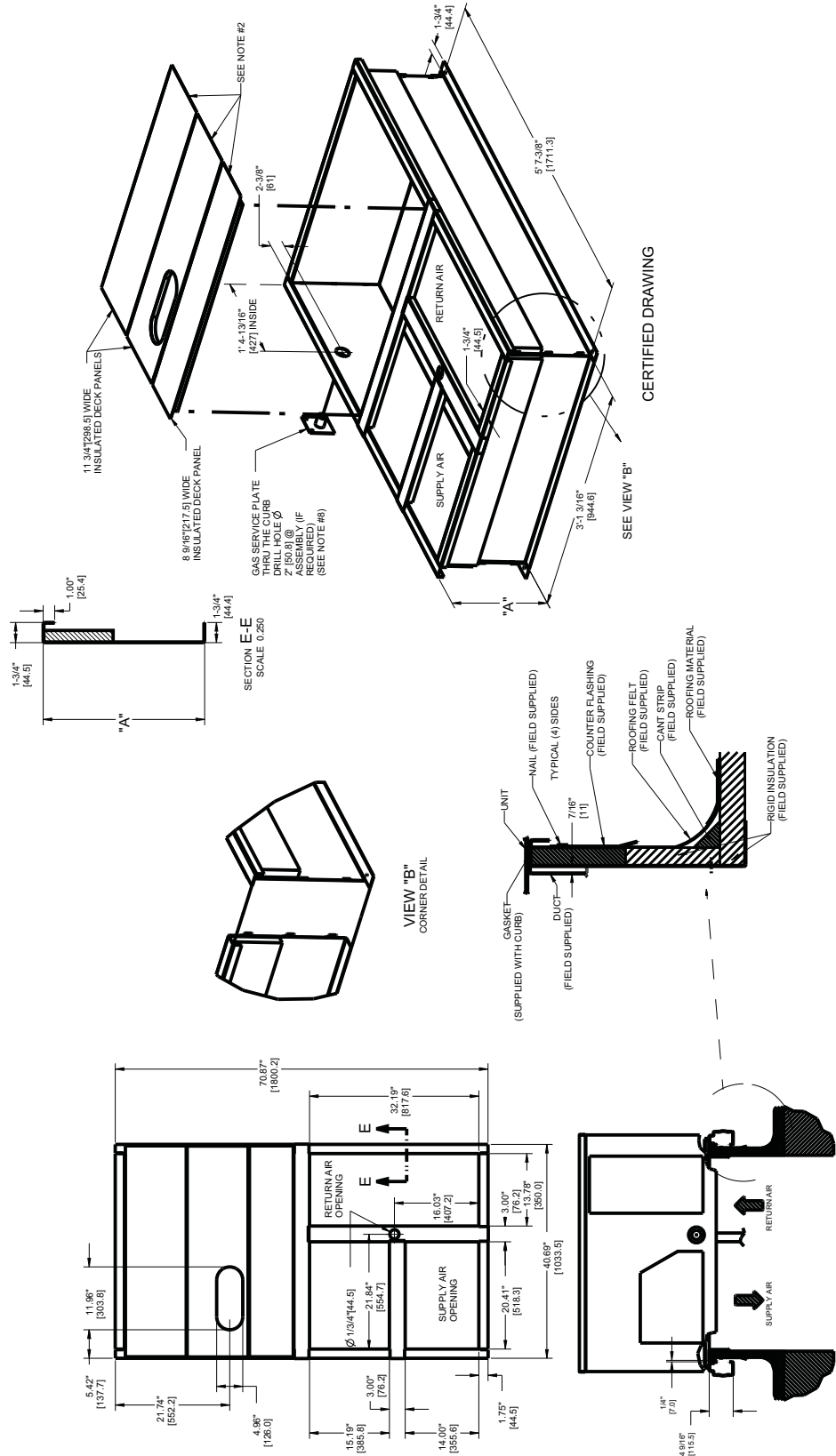



# BASE UNIT DIMENSIONS – RGS090–121

**NOTES:**

1. DIMENSIONS ARE IN INCHES, DIMENSIONS IN [ ] ARE IN MILLIMETERS.
2. CENTER OF GRAVITY
3. DIRECTION OF AIR FLOW

CONNECTION SIZES	
A	1 3/8" [35] DIA FIELD POWER SUPPLY HOLE
B	2 1/2" [64] DIA POWER SUPPLY KNOCKOUT
C	1 3/4" [51] DIA GAUGE ACCESS PLUG
D	7/8" [22] DIA FIELD CONTROL WIRING HOLE
E	3/4"-14 NPT CONDENSATE DRAIN
F	1/2"-14 NPT GAS CONNECTION 3/4"-14 NPT GAS CONNECTION
G	2" [51] DIA POWER SUPPLY KNOCK-OUT

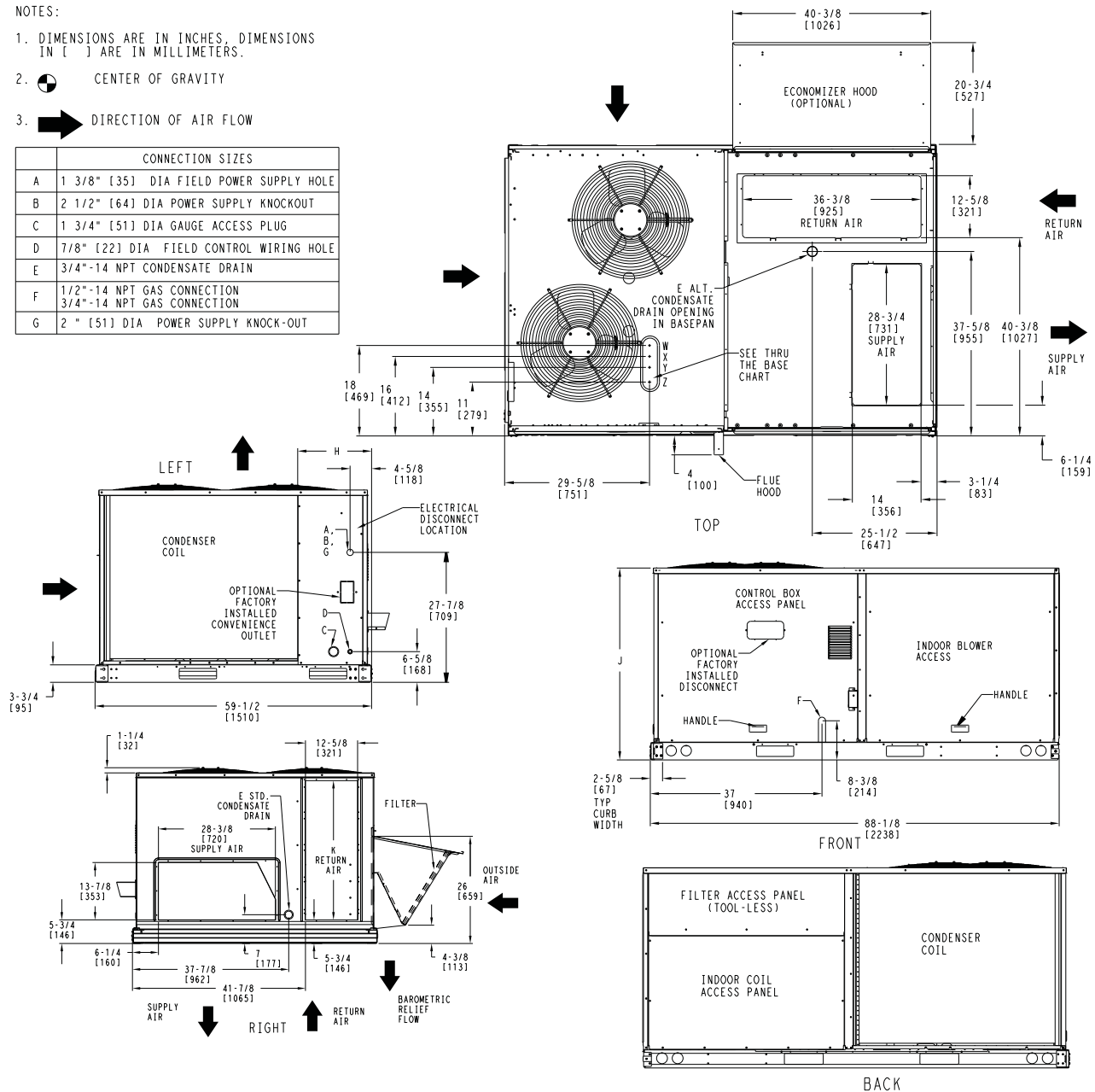

UNIT	OUTDOOR COIL TYPE	J	K	H
091	RTPF	41 1/4 [1048]	33 3/4 [857]	15 7/8 [403]
101	RTPF	49 3/8 [1253]	36 3/8 [925]	27 7/8 [708]
121	RTPF	49 3/8 [1253]	36 3/8 [925]	15 7/8 [403]
090	RTPF	41 1/4 [1048]	33 3/4 [857]	15 7/8 [403]
102	RTPF	49 3/8 [1253]	36 3/8 [925]	15 7/8 [403]
120	RTPF	49 3/8 [1253]	36 3/8 [925]	15 7/8 [403]
090	MCHX	41 1/4 [1048]	33 3/4 [857]	23 [584.2]
120	MCHX	49 3/8 [1253]	36 3/8 [925]	11 [279.4]

RTPF - ROUND TUBE, PLATE FIN (COPPER/ALUM)  
MCHX - NOVATION (ALUM/ALUM)

THRU-THE-BASE CHART (FIELD INST)			
THESE HOLES REQUIRED FOR USE WITH ACCY KITS: CRBTMPWR002A01: GAS THRU CURB CRBTMPWR004A01: GAS THRU BASEPAN			
	THREADED CONDUIT SIZE	WIRE USE	REQ'D HOLE SIZES (MAX.)
W	1/2"	ACC.	7/8" [22.2]
X	1/2"	24V	7/8" [22.2]
Y	1 1/4" (002,004)	POWER	1 3/4" [44.4]
Z *	(004) 3/4" FPT	GAS	1 3/4" [44.4]
*	(002) PROVIDES 3/4" FPT THRU CURB FLANGE & FITTING.		HOLE SIZE: 2" [50.8]

THRU-THE-BASE CHART (FIOP)	
FOR "THRU-THE-BASEPAN" FACTORY OPTION, FITTINGS FOR ONLY X, Y, & Z ARE PROVIDED. **	
**	FOR BELOW LISTED MODELS, A FIELD SUPPLIED 1/2" ADAPTER IS REQUIRED BETWEEN BASE PAN FITTING AND GAS VALVE: 48TCD, S*08.09

## WEIGHT & CLEARANCE DIMENSIONS – RGS090–121 (cont.)

UNIT	BASE UNIT WEIGHT		Corner Weight A		Corner Weight B		Corner Weight C		Corner Weight D		Center of Gravity In [mm]		
	LBS	KG	LBS	KG	LBS	KG	LBS	KG	LBS	KG	X	Y	Z
RGS091	780	354	178	81	158	72	209	95	236	107	42 [1054]	34 [864]	21 [521]
RGS101	920	418	212	96	183	83	243	110	282	128	41 [1038]	34 [864]	23 [587]
RGS121	930	422	216	98	196	89	241	112	272	124	42 [1067]	33 [841]	24 [616]
RGS090	835	379	164	75	170	77	255	116	246	112	45 [1140]	36 [905]	19 [492]
RGS102	930	422	228	104	187	85	232	105	283	129	40 [1010]	33 [835]	19 [473]
RGS120	940	427	231	105	189	86	234	106	286	130	40 [1010]	33 [835]	19 [470]

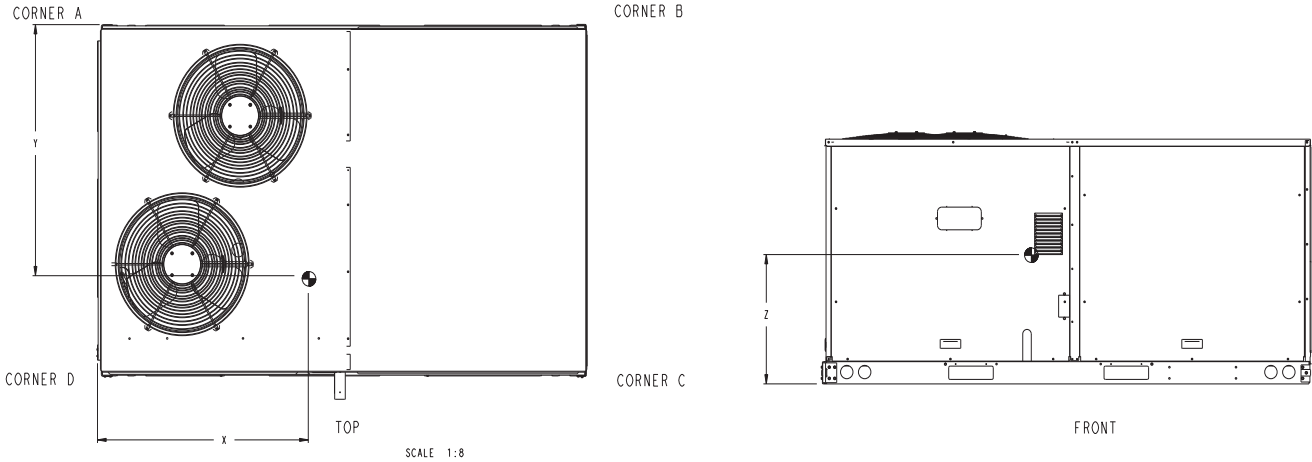

C10299

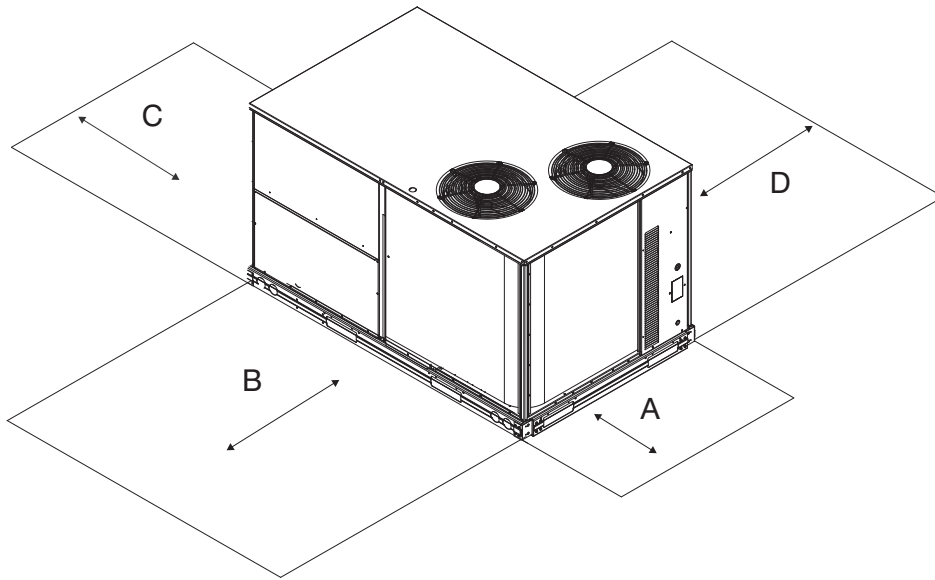

C11247

UNIT CLEARANCES		
LOC	DIMENSION	CONDITION
A	48" (1219 mm)	Unit disconnect is mounted on panel
	18" (457 mm)	No disconnect, convenience outlet option
	18" (457 mm)	Recommended service clearance
	12" (305 mm)	Minimum clearance
B	42" (1067 mm)	Surface behind servicer is grounded (e.g., metal, masonry wall)
	36" (914 mm)	Surface behind servicer is electrically non-conductive (e.g., wood, fiberglass)
	Special	Check for sources of flue products within 10-ft of unit fresh air intake hood
C	36" (914 mm)	Side condensate drain is used
	18" (457 mm)	Minimum clearance
D	48" (1219 mm)	No flue discharge accessory installed, surface is combustible material
	42" (1067 mm)	Surface behind servicer is grounded (e.g., metal, masonry wall, another unit)
	36" (914 mm)	Surface behind servicer is electrically non-conductive (e.g., wood, fiberglass)
	Special	Check for adjacent units or building fresh air intakes within 10-ft of this unit's flue outlet

**NOTE:** Unit not designed to have overhead obstruction. Contact Application Engineering for guidance on any application planning overhead obstruction or vertical clearances.





## WEIGHT & CLEARANCE DIMENSIONS – RGS150 (cont.)

UNIT	BASE UNIT WEIGHT		Corner Weight A		Corner Weight B		Corner Weight C		Corner Weight D		Center of Gravity In [mm]		
	LBS	KG	LBS	KG	LBS	KG	LBS	KG	LBS	KG	X	Y	Z
RGS150	1167	530	349	159	167	76	211	96	440	200	31–3/8 [797]	34–3/4 [883]	21–7/8 [556]

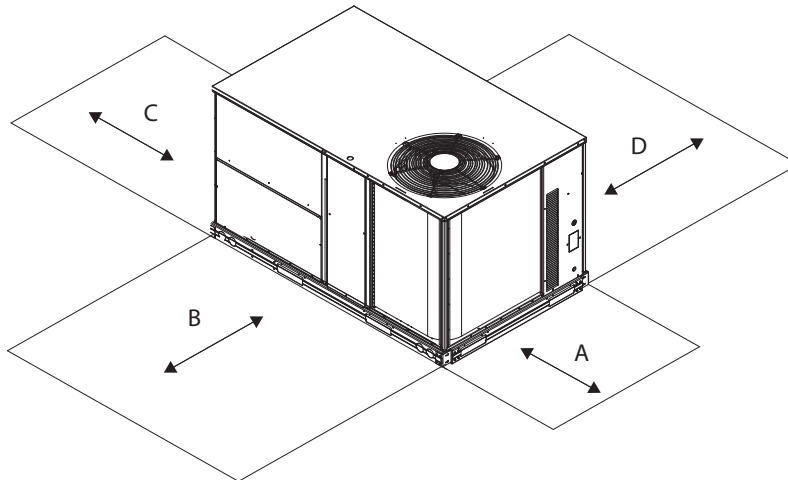
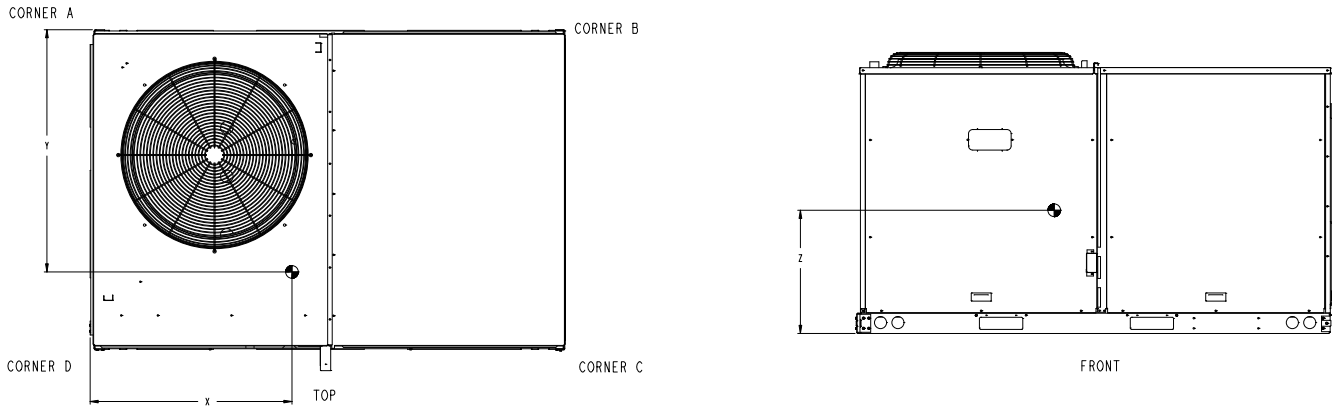

UNIT CLEARANCES		
LOC	DIMENSION	CONDITION
A	48" (1219 mm)	Unit disconnect is mounted on panel
	18" (457 mm)	No disconnect, convenience outlet option
	18" (457 mm)	Recommended service clearance
	12" (305 mm)	Minimum clearance
B	42" (1067 mm)	Surface behind servicer is grounded (e.g., metal, masonry wall)
	36" (914 mm) Special	Surface behind servicer is electrically non-conductive (e.g., wood, fiberglass) Check for sources of flue products within 10-ft of unit fresh air intake hood
C	36" (914 mm)	Side condensate drain is used
	18" (457 mm)	Minimum clearance
D	48" (1219 mm)	No flue discharge accessory installed, surface is combustible material
	42" (1067 mm)	Surface behind servicer is grounded (e.g., metal, masonry wall, another unit)
	36" (914 mm)	Surface behind servicer is electrically non-conductive (e.g., wood, fiberglass)
	Special	Check for adjacent units or building fresh air intakes within 10-ft of this unit's flue outlet

**NOTE:** Unit not designed to have overhead obstruction. Contact Application Engineering for guidance on any application planning overhead obstruction or vertical clearances.



# WEIGHT & CLEARANCE DIMENSIONS – RGS180 (cont.)

UNIT	STD UNIT WEIGHT		CORNER WEIGHT (A)		CORNER WEIGHT (B)		CORNER WEIGHT (C)		CORNER WEIGHT (D)		C.G.		
	LBS.	KG.	LBS.	KG.	LBS.	KG.	LBS.	KG.	LBS.	KG.	X	Y	Z
180	1380	627	295	134	276	126	342	156	421	191	64 1/4 [1630]	35 [890]	21 1/8 [537]

STANDARD UNIT WEIGHT IS WITH LOW HEAT & WITHOUT PACKAGING.  
FOR OPTIONS & ACCESSORIES, REFER TO THE PRODUCT DATA CATALOG.

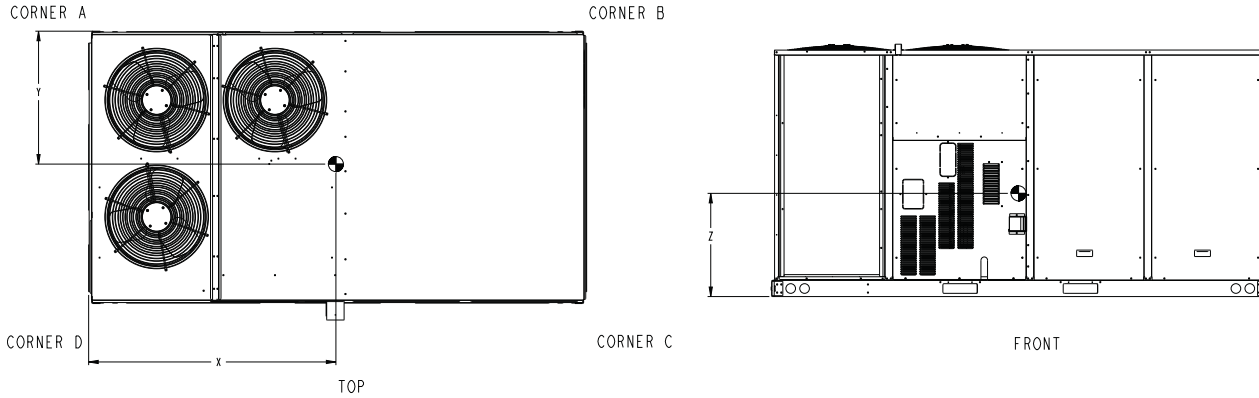

## Dimensions

C14152

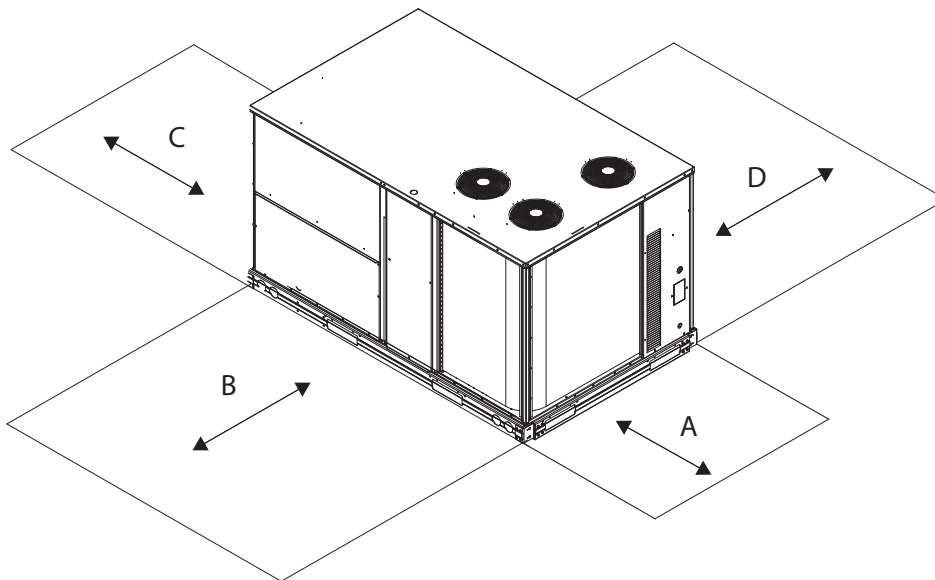

## Service Clearance

C10578B

LOC	DIMENSION	CONDITION
A	48-in (1219 mm)	Unit disconnect is mounted on panel
	18-in (457 mm)	No disconnect, convenience outlet option
	18-in (457 mm)	Recommended service clearance
	12-in (305 mm)	Minimum clearance
B	42-in (1067 mm)	Surface behind servicer is grounded (e.g., metal, masonry wall)
	36-in (914 mm)	Surface behind servicer is electrically non-conductive (e.g., wood, fiberglass)
	Special	Check for sources of flue products within 10-ft of unit fresh air intake hood
C	36-in (914 mm)	Side condensate drain is used
	18-in (457 mm)	Minimum clearance
D	48-in (1219 mm)	No flue discharge accessory installed, surface is combustible material
	42-in (1067 mm)	Surface behind servicer is grounded (e.g., metal, masonry wall, another unit)
	36-in (914 mm)	Surface behind servicer is electrically non-conductive (e.g., wood, fiberglass)
	Special	Check for adjacent units or building fresh air intakes within 10-ft of this unit's flue outlet

**NOTE:** Unit not designed to have overhead obstruction. Contact Application Engineering for guidance on any application planning overhead obstruction or vertical clearances.

# ROOF CURB DETAILS - RGS180

## LARGE DUCT OPENINGS

- NOTES:
1. ROOFCURB ACCESSORY IS SHIPPED DISASSEMBLED.
  2. INSULATED PANELS: 1/2" THK. NEOPRENE FOAM, 1.0# DENSITY.
  3. DIMENSIONS IN [ ] ARE IN MILLIMETERS.
  4. ROOFCURB ACCESSORY GASKETS ARE SUPPLIED WITH THE ROOFCURB ACCESSORY.
  5. ROOFCURB ACCESSORY GASKETS ARE SUPPLIED WITH THE ROOFCURB ACCESSORY.
  6. SERVICE CLEARANCE 4 FT ON EACH SIDE.
  7. → DIRECTION OF AIR FLOW.
  8. "L" & "S" DESIGNATIONS DENOTE LOCATION OF COMMON CROSS RAIL. (POSITION "L" FOR LARGE DUCT OPENING CURB).

ROOF CURB ACCESSORY #	A
CRFCURB074A00	14" [356]
CRFCURB075A00	24" [610]

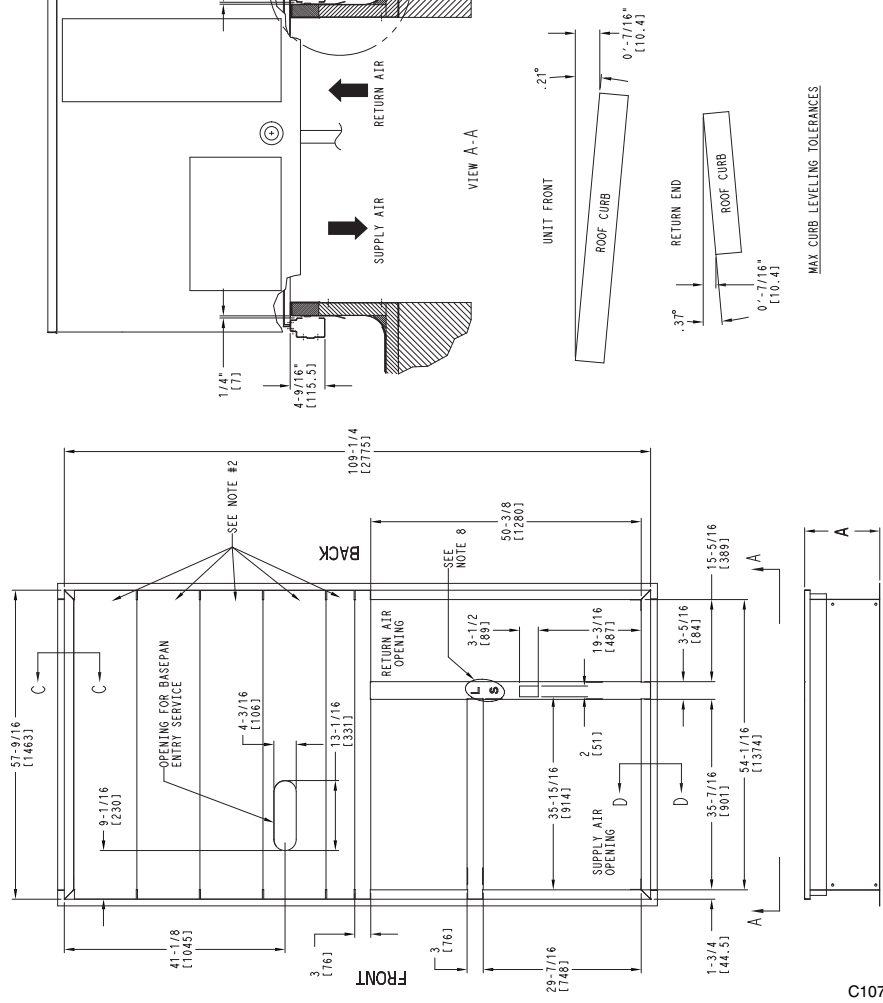
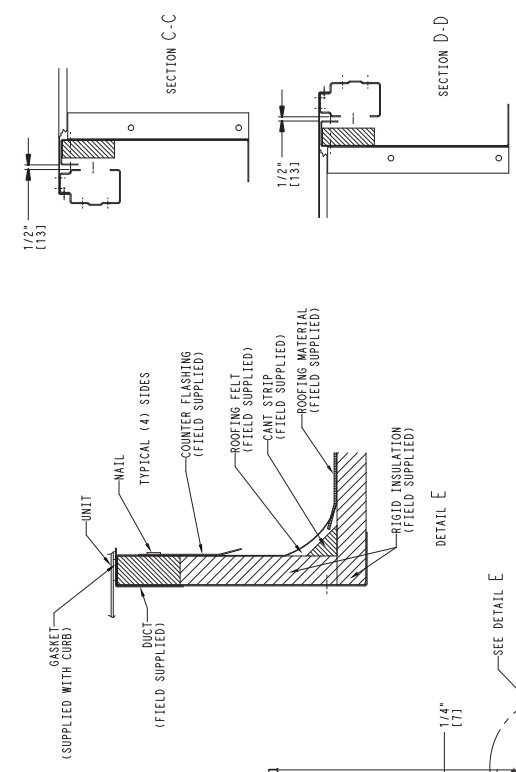

C10772



## OPTIONS & ACCESSORY WEIGHTS

OPTION / ACCESSORY	OPTION / ACCESSORY WEIGHTS																	
	036		048		060		072		090/191		101/102		120/121		150		180	
	lb	kg	lb	kg	lb	kg	lb	kg	lb	kg	lb	kg	lb	kg	lb	kg	lb	kg
Power Exhaust – vertical	50	23	50	23	50	23	50	23	75	34	75	34	75	34	75	34	85	39
Power Exhaust – horizontal	30	14	30	14	30	14	30	14	30	14	30	14	30	14	30	14	75	34
Economizer (IV or X)	50	23	50	23	50	23	50	23	75	34	75	34	75	34	75	34	115	52
Two Position damper	39	18	39	18	39	18	39	18	58	26	58	26	58	26	58	26	65	29
Manual Dampers	12	5	12	5	12	5	12	5	18	8	18	8	18	8	18	8	25	11
Medium Gas Heat	12	5	9	4	9	4	9	4	15	7	15	7	18	8	18	8	28	13
High Gas Heat	–	–	17	8	17	8	17	8	29	13	29	13	35	16	35	16	50	23
Hail Guard (louvered)	16	7	16	7	16	7	16	7	34	15	34	15	34	15	34	15	45	20
Cu/Cu Condenser Coil <sup>1</sup>	6	3	13	6	13	6	15	7	12	5	23	10	23	10	23	10	190	86
Cu/Cu Condenser and Evap. Coils <sup>1</sup>	12	5	19	9	21	10	26	12	25	11	49	22	49	22	49	22	280	127
Roof Curb (14–in. curb)	115	52	115	52	115	52	115	52	143	65	143	65	143	65	143	65	180	82
Roof Curb (24–in. curb)	197	89	197	89	197	89	197	89	245	111	245	111	245	111	245	111	255	116
CO <sub>2</sub> sensor	5	2	5	2	5	2	5	2	5	2	5	2	5	2	5	2	5	2
Flue Discharge Deflector	7	3	7	3	7	3	7	3	7	3	7	3	7	3	7	3	7	3
Optional Indoor Motor/Drive	10	5	10	5	10	5	10	5	15	7	15	7	15	7	15	7	45	20
Motor Master Controller	35	16	35	16	35	16	35	16	35	16	35	16	35	16	40	18	40	18
Supply Smoke Detector	5	2	5	2	5	2	5	2	5	2	5	2	5	2	5	2	5	2
Non–Fused Disconnect	15	7	15	7	15	7	15	7	15	7	15	7	15	7	15	7	15	7
Non–Powered Convenience outlet	5	2	5	2	5	2	5	2	5	2	5	2	5	2	5	2	5	2
Enthalpy Sensor	2	1	2	1	2	1	2	1	2	1	2	1	2	1	2	1	2	1
Differential Enthalpy Sensor	3	1	3	1	3	1	3	1	3	1	3	1	3	1	3	1	3	1
2–Speed System with VFD	–	–	–	–	–	–	–	–	20	9	20	9	20	9	20	9	20	9

**NOTE:** Where multiple variations are available, the heaviest combination is listed.

<sup>1</sup> Where available.

# APPLICATION DATA

## Min operating ambient temp (cooling):

In mechanical cooling mode, your rooftop can safely operate down to an outdoor ambient temperature of 25°F (-4°C), with an accessory winter start kit; 40°F (4°C) standard min operating temperature. It is possible to provide cooling at lower outdoor ambient temperatures by using less outside air, economizers, and/or accessory low ambient kits.

## Max operating ambient temp (cooling):

The maximum operating ambient temperature for cooling mode is 115°F (46°C). While cooling operation above 115°F (46°C) may be possible, it could cause either a reduction in performance, reliability, or a protective action by the unit's internal safety devices.

## Min mixed air temp (heating):

Using the factory settings, the minimum temperatures for the mixed air (the combined temperature of the warm return air and the cold outdoor air) entering the dimpled, gas heat exchangers are:

<u>Aluminized</u>	<u>Stainless Steel</u>
50°F (10°C) continuous	40°F (4°C) continuous
45°F (7°C) intermittent	35°F (2°C) intermittent

Operating at lower mixed-air temperatures may be possible, if a field-supplied, outdoor air thermostat initiates both heat stages when the temperature is less than the minimum temperatures listed above. Please contact your local representative for assistance.

## Min and max airflow (heating and cooling):

To maintain safe and reliable operation of your rooftop, operate within the heating airflow limits during heating mode and cooling airflow limits during cooling mode. Operating above the max may cause blow-off, undesired airflow noise, or airflow related problems with the rooftop unit. Operating below the min may cause problems with coil freeze-up and unsafe heating operation. Heating and cooling limitations differ when evaluating operating CFM, the minimum value is the HIGHER of the cooling and heating minimum CFM values published in Table 7 and the maximum value is the LOWER of the cooling and heating minimum values published in Table 7.

## Heating-to-cooling changeover:

Your unit will automatically change from heating to cooling mode when using a thermostat with an auto-change-over feature.

## Airflow:

All units are draw-through in cooling mode and blow-through in heating mode.

## Outdoor air application strategies:

Economizers reduce operating expenses and compressor run time by providing a free source of cooling and a means of ventilation to match application changing needs. In fact, they should be considered for most applications. Also, consider the various economizer control methods and their benefits, as well as sensors required to accomplish your application goals. Please contact your local sales representative for assistance.

## Motor limits, break horsepower (BHP):

Due to the internal unit design, air path, and specially designed motors, the full horsepower (maximum continuous BHP) band, as listed in Table 8, 10, and 11, can be used with the utmost confidence. There is no need for extra safety factors, the motors are designed and rigorously tested to use the entire, listed BHP range without either nuisance tripping or premature motor failure.

## Propane heating:

Liquid propane (LP) has different physical qualities than natural gas. As a result, LP requires different fuel to air mixture. To optimize the fuel/air mixture for LP, different burner orifices in an easy to install accessory kits are available from your distributor. To select the correct burner orifices or determine the heat capacity for an LP application the selection software, or the unit's service manual.

## High altitude heating:

High altitudes have less oxygen, which affects the fuel/air mixture in heat exchangers. In order to maintain a proper fuel/air mixture, heat exchangers operating in altitudes above 2000 ft (610m) require different orifices. To select the correct burner orifices or determine the heat capacity for a high altitude application either the selection software, or the unit's service manual.

High altitudes have less oxygen, which means heat exchangers need less fuel. The new gas orifices in this field-installed kit make the necessary adjustment for high altitude applications. They restore the optimal fuel to air mixture and maintain healthy combustion on altitudes above 2000 ft (610m).

**NOTE:** Typical natural gas heating value ranges from 975 to 1050 Btu/ft<sup>3</sup> at sea level nationally. The heating value goes down approximately 1.7% per every thousand feet elevation. Standard factory orifices can typically be used up to 2000 ft (610m) elevation without any operational issues.

**NOTE:** For installations in Canada, the input rating should be derated by 10% for altitudes from 2000 ft (610m) to 4500 ft (1372m) above sea level.

## Sizing a rooftop

Bigger isn't necessarily better. While an air conditioner needs to have enough capacity to meet the design loads, it doesn't need excess capacity. In fact, excess capacity typically results in very poor part load performance and humidity control.

Using higher design temperatures than ASHRAE recommends for your location, adding "safety factors" to the calculated load, are all signs of oversizing air conditioners. Oversizing the air conditioner leads to short cycling ( quick on-off cycles ) which results in poor humidity control, reduced efficiency, higher utility bills, larger indoor temperature swings, excessive noise, and increased wear and tear on the air conditioner.

Rather than oversizing an air conditioner, engineers should "right-size" or even slightly undersize air conditioners. Correctly sizing an air conditioner controls humidity better; promotes efficiency; reduces utility bills; extends equipment life, and maintains even, comfortable temperatures. Please contact your local representative for assistance.

## Low ambient applications

The optional economizer can adequately cool your space by bringing in fresh, cool outside air. In fact, when so equipped, accessory low-ambient kit may not be necessary. In low ambient conditions, unless the outdoor air is excessively humid or contaminated, economizer-based "free cooling" is the preferred less costly and energy conscious method.

In low ambient applications where outside air might not be desired (such as contaminated or excessively humid outdoor environments), your rooftop can operate to ambient temperatures down to -20°F (-29°C) using the recommended accessory Motormaster low ambient controller.

## **2-Speed Indoor Fan Motor System with Variable Frequency Drive (VFD)**

The 2-Speed Indoor Fan Motor System utilizes a Variable Frequency Drive (VFD) to automatically adjust the indoor fan motor speed in sequence with the units cooling operation. Per ASHRAE 90.1 2010 standard section 6.4.3.10.b, during the first stage of cooling operation the VFD will adjust the fan motor to provide 2/3rd of the total cfm established for the unit. When a call for the second stage of cooling is required, the VFD will allow the total cfm for the unit established (100%). During the heating mode, the VFD will allow total design cfm (100%) operation and during the ventilation mode the VFD will allow operation to 2/3rd of total cfm.

The VFD used in the 2-Speed Indoor Fan Motor System has soft start capabilities to slowly ramp up the speeds, thus eliminating any high inrush air volume during initial start-up. It also has internal over current protection for the fan motor and a field installed display kit that allows adjustment and in depth diagnostics of the VFD.

This 2-Speed Indoor Fan Motor System is available on models with 2-stage cooling operation with electrical mechanical or RTU Open (multi Protocol) controls. Both space sensor and conventional thermostats/controls can be used to provide accurate control in any application.

The 2-Speed Indoor Fan Motor System is very flexible for initial fan performance set up and adjustment. The standard factory shipped VFD is pre programmed to automatically stage the fan speed between the first and second stage of cooling. The unit fan performance static pressure and cfm can be easily adjusted using the traditional means of pulley adjustments. The other means to adjust the unit static and cfm performance is to utilize the field installed display module and adjust the frequency and voltage in the VFD to required performance requirements. In either case, once set up the VFD will automatically adjust the speed between the cooling stage operation.

# SELECTION PROCEDURE (WITH RGS072 EXAMPLE)<sup>1</sup>

## I. Determine cooling and heating loads.

### Given:

Mixed air drybulb	80°F (27°C)
Mixed air wetbulb	67°F (19°C)
Ambient drybulb	95°F (35°C)
TC <sub>Load</sub>	72.0 MBH
SHC <sub>Load</sub>	54.0 MBH
Vertical supply air	2100 CFM
Heating load	85.0 MBH
External static pressure	0.67 in.wg
Electrical characteristics	230–3–60

## II. Make an initial guess at cooling tons.

$$\text{Refrig. tons} = \text{TC}_{\text{Load}} / 12 \text{ MBH per ton}$$

$$\text{Refrig. tons} = 72.0 / 12 = 6.0 \text{ tons}$$

In this case, start by looking at the RGS072.

## III. Look up the rooftop's TC and SHC.

Table 18 shows that, at the application's supply air CFM, mixed air and ambient temperatures, the RGS072 supplies:

$$\text{TC} = 73.7 \text{ MBH}$$

$$\text{SHC} = 54.3 \text{ MBH.}$$

## IV. Calculate the building latent heat load.

$$\text{LHC}_{\text{Load}} = \text{TC}_{\text{Load}} - \text{SHC}_{\text{Load}}$$

$$\text{LHC}_{\text{Load}} = 72.0 \text{ MBH} - 54.0 \text{ MBH} = 18.0 \text{ MBH}$$

## V. Calculate RTU latent heat capacity.

$$\text{LHC} = \text{TC} - \text{SHC}$$

$$\text{LHC} = 73.7 \text{ MBH} - 54.3 \text{ MBH} = 19.4 \text{ MBH}$$

## VI. Compare RTU capacities to loads.<sup>2,3</sup>

Compare the rooftop's SHC and LHC to the building's sensible and latent heat loads.

### Legend

BHP	— Brake horsepower
FLA	— Full load amps
LC	— Latent capacity
LRA	— Lock rotor amp
MBH	— (1,000) BTUH
MCA	— Min. circuit ampacity
MOCP	— Max. over-current protection
RPM	— Revolutions per minute
RTU	— Rooftop unit
SHC	— Sensible heat capacity
TC	— Total capacity

## VII. Select factory options (FIOP)

Local code requires an economizer for any unit with TC less than 65.0 MBH.

## VIII. Calculate the total static pressure.

$$\text{External static pressure} \quad 0.67 \text{ in. wg}$$

$$\text{Sum of FIOP / Accessory static} \quad +0.13 \text{ in. wg}$$

$$\text{Total Static Pressure} \quad 0.80 \text{ in. wg}$$

## IX. Look up the indoor fan RPM & BHP.

Table 39 shows, at 2100 CFM & ESP= 0.8, RPM = 1358 & BHP = 1.52

## X. Convert BHP (Step VIII) into fan motor heat.

$$\text{Fan motor heat} = 2.546^* \text{ BHP/Motor Eff.}^4$$

$$\text{Fan motor heat} = 4.9 \text{ MBH}$$

## XI. Calculate RTU heating capacity.

$$\text{Building heating load} \quad 85.0 \text{ MBH}$$

$$\text{Fan motor heat} \quad -4.9 \text{ MBH}$$

$$\text{Required heating capacity} \quad 80.1 \text{ MBH}$$

## XII. Select a gas heater.

Table 4 shows the heating capacities of the RGS072 = 93.0 MBH. Select the RGS072

## XIII. Determine electrical requirements.

Table 75 shows the MCA and MOCP of a RGS072 (without convenience outlet) as:

$$\text{MCA} = 30.5 \text{ amps} \ \& \ \text{MOCP} = 45.0 \text{ amps}$$

$$\text{Min. disconnect size: FLA} = 30 \ \& \ \text{LRA} = 157.$$

### NOTES:

1. Selection software saves time by performing many of the steps above. Contact your sales representative for assistance.
2. Unit ratings are gross capacities and do not include the effect of evaporator fan motor heat. See Step X. for determining amount of evaporator fan motor heat to subtract from total and sensible capacities to obtain net cooling and net sensible capacities.
3. Selecting a unit with a SHC slightly lower than the SHC<sub>Load</sub> is often better than oversizing. Slightly lower SHC's will help control indoor humidity, and prevent temperature swings.
4. Indoor fan motor efficiency is available in Tables 51–67. Use the decimal form in the equation, eg. 80% = .8.

**Table 13 – COOLING CAPACITIES – 1 STAGE – 3 TONS**

RGS036			AMBIENT TEMPERATURE											
			85			95			105			115		
			EAT (db)			EAT (db)			EAT (db)			EAT (db)		
			75	80	85	75	80	85	75	80	85	75	80	85
900 Cfm	EAT (wb)	58 TC	28.1	28.1	31.7	26.3	26.3	29.8	24.5	24.5	27.7	22.6	22.6	25.5
		58 SHC	24.4	28.1	31.7	22.9	26.3	29.8	21.3	24.5	27.7	19.6	22.6	25.5
		62 TC	30.3	30.3	31.0	27.8	27.8	29.8	25.1	25.1	28.4	22.6	22.6	26.5
		62 SHC	22.6	26.8	31.0	21.5	25.7	29.8	20.2	24.3	28.4	18.7	22.6	26.5
		67 TC	35.5	35.5	35.5	33.1	33.1	33.1	30.5	30.5	30.5	27.5	27.5	27.5
		67 SHC	19.5	23.7	27.9	18.5	22.7	26.9	17.4	21.6	25.8	16.2	20.4	24.6
1050Cfm	EAT (wb)	72 TC	39.0	39.0	39.0	37.1	37.1	37.1	35.1	35.1	35.1	32.7	32.7	32.7
		72 SHC	15.3	19.5	23.7	14.5	18.8	23.0	13.7	17.9	22.2	12.9	17.1	21.3
		76 TC	-	41.4	41.4	-	39.6	39.6	-	37.6	37.6	-	35.4	35.4
		76 SHC	-	16.0	21.0	-	15.4	20.2	-	14.6	19.3	-	13.8	18.3
		58 TC	30.2	30.2	34.2	28.4	28.4	32.2	26.5	26.5	30.0	24.5	24.5	27.7
		58 SHC	26.3	30.2	34.2	24.7	28.4	32.2	23.1	26.5	30.0	21.3	24.5	27.7
1200 Cfm	EAT (wb)	62 TC	31.9	31.9	34.2	29.4	29.4	32.8	26.7	26.7	31.2	24.5	24.5	28.8
		62 SHC	24.6	29.4	34.2	23.4	28.1	32.8	22.0	26.6	31.2	20.3	24.5	28.8
		67 TC	36.7	36.7	36.7	34.8	34.8	34.8	32.2	32.2	32.2	29.1	29.1	29.1
		67 SHC	20.6	25.4	30.2	19.8	24.6	29.4	18.8	23.6	28.4	17.6	22.4	27.2
		72 TC	40.1	40.1	40.1	38.2	38.2	38.2	36.1	36.1	36.1	33.7	33.7	33.7
		72 SHC	15.7	20.5	25.3	15.0	19.8	24.6	14.2	19.0	23.8	13.4	18.2	23.0
1350 Cfm	EAT (wb)	76 TC	-	42.4	42.4	-	40.6	40.6	-	38.5	38.5	-	36.2	36.2
		76 SHC	-	16.6	22.2	-	15.9	21.3	-	15.2	20.4	-	14.4	19.5
		58 TC	32.2	32.2	36.4	30.4	30.4	34.3	28.4	28.4	32.1	26.3	26.3	29.7
		58 SHC	28.0	32.2	36.4	26.4	30.4	34.3	24.7	28.4	32.1	22.8	26.3	29.7
		62 TC	33.3	33.3	37.0	30.8	30.8	35.5	28.4	28.4	33.4	26.3	26.3	30.9
		62 SHC	26.4	31.7	37.0	25.1	30.3	35.5	23.4	28.4	33.4	21.7	26.3	30.9
2500 Cfm	EAT (wb)	67 TC	37.7	37.7	37.7	35.6	35.6	35.6	33.4	33.4	33.4	30.4	30.4	30.4
		67 SHC	21.7	27.0	32.4	20.9	26.3	31.6	20.0	25.4	30.8	18.8	24.2	29.6
		72 TC	40.9	40.9	40.9	39.0	39.0	39.0	36.9	36.9	36.9	34.4	34.4	34.4
		72 SHC	16.1	21.5	26.8	15.4	20.8	26.1	14.7	20.0	25.4	13.8	19.2	24.5
		76 TC	-	43.1	43.1	-	41.3	41.3	-	39.1	39.1	-	36.8	36.8
		76 SHC	-	17.1	23.1	-	16.4	22.3	-	15.7	21.4	-	14.9	20.5
2500 Cfm	EAT (wb)	58 TC	-	-	-	32.1	32.1	36.3	30.0	30.0	34.0	27.9	27.9	31.5
		58 SHC	-	-	-	27.9	32.1	36.3	26.1	30.0	34.0	24.2	27.9	31.5
		62 TC	28.4	28.4	30.5	32.2	32.2	37.8	30.1	30.1	35.3	27.9	27.9	32.8
		62 SHC	17.6	24.1	30.5	26.6	32.2	37.8	24.8	30.1	35.3	23.0	27.9	32.8
		67 TC	33.2	33.2	33.2	36.4	36.4	36.4	34.1	34.1	34.1	31.5	31.5	32.0
		67 SHC	15.0	21.4	27.9	21.9	27.8	33.7	21.0	26.9	32.9	20.0	26.0	32.0
		72 TC	37.5	37.5	37.5	39.7	39.7	39.7	37.5	37.5	37.5	35.0	35.0	35.0
		72 SHC	11.8	18.3	24.8	15.8	21.7	27.5	15.0	20.9	26.8	14.2	20.1	26.0
		76 TC	-	40.1	40.1	-	41.8	41.8	-	39.6	39.6	-	37.3	37.3
		76 SHC	-	15.3	22.7	-	16.8	23.2	-	16.1	22.3	-	15.3	21.5
		58 TC	28.1	28.1	34.2	33.7	33.7	38.1	31.6	31.6	35.7	29.3	29.3	33.2
		58 SHC	21.9	28.1	34.2	29.3	33.7	38.1	27.4	31.6	35.7	25.5	29.3	33.2
62 TC	30.3	30.3	33.8	33.7	33.7	39.6	31.6	31.6	37.1	29.4	29.4	34.5		
62 SHC	19.8	26.8	33.8	27.8	33.7	39.6	26.1	31.6	37.1	24.2	29.4	34.5		
67 TC	35.5	35.5	35.5	36.9	36.9	36.9	34.6	34.6	34.9	32.0	32.0	34.0		
67 SHC	16.7	23.7	30.7	22.8	29.2	35.7	21.9	28.4	34.9	21.0	27.5	34.0		
72 TC	39.0	39.0	39.0	40.2	40.2	40.2	38.0	38.0	38.0	35.5	35.5	35.5		
72 SHC	12.4	19.5	26.6	16.1	22.5	28.8	15.4	21.7	28.1	14.6	21.0	27.4		
76 TC	-	41.4	41.4	-	42.2	42.2	-	40.0	40.0	-	-	-		
76 SHC	-	16.0	24.3	-	17.2	24.0	-	16.5	23.2	-	-	-		

**LEGEND:**

- Do not operate
- Cfm - Cubic feet per minute (supply air)
- EAT(db) - Entering air temperature (dry bulb)
- EAT(wb) - Entering air temperature (wet bulb)
- SHC - Sensible heat capacity
- TC - Total cooling capacity

3 TONS – UNIT WITH HOT GAS REHEAT SYSTEM IN SUBCOOLING MODE										
Air Entering Evaporator – CFM										
Temp (F) Air Ent Condenser (Edb)		80 dry bulb 72 wet bulb			80 dry bulb 67 wet bulb			80 dry bulb 62 wet bulb		
		900	1200	1500	900	1200	1500	900	1200	1500
		75	TC	40.6	43.2	45.3	37.0	39.4	41.3	33.4
SHC	21.6		23.9	25.6	25.6	27.7	29.3	29.6	31.6	33.1
kW	2.0		2.0	2.0	2.0	2.0	2.0	2.0	2.0	2.0
85	TC	37.0	39.6	41.7	33.6	36.0	37.9	30.2	32.3	34.1
	SHC	17.7	20.2	22.2	22.7	25.0	26.9	27.7	29.9	31.6
	kW	2.3	2.3	2.3	2.3	2.3	2.3	2.3	2.3	2.3
95	TC	33.5	36.0	38.1	30.2	32.5	34.4	26.9	29.1	30.8
	SHC	13.7	16.6	18.8	19.7	22.4	24.4	25.7	28.2	30.1
	kW	2.6	2.6	2.6	2.5	2.5	2.5	2.5	2.5	2.5
105	TC	29.9	32.4	34.5	26.8	29.1	31.0	23.6	25.8	27.5
	SHC	9.8	12.9	15.3	16.8	19.7	22.0	23.8	26.5	28.6
	kW	2.9	2.9	2.9	2.8	2.8	2.8	2.8	2.8	2.8
115	TC	26.3	28.8	30.9	23.3	25.7	27.5	20.4	22.5	24.2
	SHC	5.8	9.2	11.9	13.8	17.0	19.5	21.9	24.8	27.1
	kW	3.2	3.2	3.2	3.1	3.1	3.1	3.1	3.1	3.1

3 TONS – UNIT WITH HOT GAS REHEAT SYSTEM IN HOT GAS REHEAT MODE										
Air Entering Evaporator – CFM										
Temp (F) Air Ent Condenser (Edb)		75 dry bulb 62.5 wet bulb (50% relative)			75 dry bulb 64 wet bulb (55% relative)			75 dry bulb 65.3 wet bulb (60% relative)		
		1050	1200	1350	1050	1200	1350	1050	1200	1350
		80	TC	14.7	15.5	16.2	15.9	16.7	17.4	16.9
SHC	6.7		7.6	8.5	4.8	5.7	6.6	3.2	4.1	5.0
kW	2.0		2.0	2.0	2.0	2.0	2.0	2.0	2.0	2.0
75	TC	15.1	15.8	16.4	16.2	17.0	17.6	17.2	18.0	18.6
	SHC	7.5	8.4	9.2	5.8	6.7	7.5	4.4	5.2	6.0
	kW	1.9	1.9	1.9	2.0	2.0	2.0	2.0	2.0	2.0
70	TC	15.5	16.1	16.7	16.6	17.3	17.9	17.5	18.2	18.8
	SHC	8.4	9.3	10.0	6.9	7.7	8.5	5.5	6.4	7.1
	kW	1.9	1.9	1.9	1.9	1.9	1.9	1.9	1.9	1.9
60	TC	16.2	16.8	17.3	17.2	17.8	18.3	18.1	18.7	19.2
	SHC	10.2	10.9	11.6	8.9	9.7	10.4	7.8	8.6	9.3
	kW	1.8	1.8	1.8	1.8	1.8	1.8	1.9	1.9	1.9
50	TC	17.0	17.5	17.9	17.9	18.4	18.8	18.7	19.2	19.6
	SHC	11.9	12.6	13.2	11.0	11.6	12.2	10.1	10.8	11.4
	kW	1.7	1.7	1.7	1.8	1.8	1.8	1.8	1.8	1.8
40	TC	17.7	18.1	18.5	18.6	19.0	19.3	19.3	19.7	20.1
	SHC	13.7	14.3	14.8	13.0	13.6	14.1	12.4	13.0	13.5
	kW	1.7	1.7	1.7	1.7	1.7	1.7	1.7	1.7	1.7

**LEGEND**

- Edb – Entering Dry-Bulb
- Ewb – Entering Wet-Bulb
- kW – Compressor Motor Power Input
- ldb – Leaving Dry-Bulb
- lwb – Leaving Wet-Bulb
- SHC – Sensible Heat Capacity (1000 Btuh) Gross
- TC – Total Capacity (1000 Btuh) Gross

**NOTES:**

4. Direct interpolation is permissible. Do not extrapolate.
5. The following formulas may be used:

$$t_{ldb} = t_{edb} - \frac{\text{sensible capacity (Btuh)}}{1.10 \times \text{cfm}}$$

$t_{lwb}$  = Wet-bulb temperature corresponding to enthalpy of air leaving evaporator coil ( $h_{lwb}$ )

$$h_{lwb} = h_{ewb} - \frac{\text{total capacity (Btuh)}}{4.5 \times \text{cfm}}$$

Where:  $h_{ewb}$  = Enthalpy of air entering evaporator coil

**Table 15 – COOLING CAPACITIES – 1 STAGE – 4 TONS**

RGS048			AMBIENT TEMPERATURE											
			85			95			105			115		
			EAT (db)			EAT (db)			EAT (db)			EAT (db)		
Cfm	EAT (wb)	TC SHC	75	80	85	75	80	85	75	80	85	75	80	85
			1200	58	TC SHC	- -	- -	- -	- -	- -	- -	36.1 31.5	36.1 36.1	40.7 40.7
1200	62	TC	43.1	43.1	43.1	40.8	40.8	40.8	38.4	38.4	39.4	35.9	35.9	38.2
		SHC	31.2	36.4	41.7	30.1	35.3	40.6	28.9	34.1	39.4	27.8	33.0	38.2
1200	67	TC	47.4	47.4	47.4	45.2	45.2	45.2	42.9	42.9	42.9	40.3	40.3	40.3
		SHC	25.9	31.2	36.4	25.0	30.2	35.5	23.9	29.2	34.4	22.9	28.2	33.4
1200	72	TC	51.1	51.1	51.1	49.1	49.1	49.1	46.8	46.8	46.8	43.9	43.9	43.9
		SHC	20.1	25.5	30.9	19.4	24.7	30.1	18.4	23.7	29.0	17.4	22.7	28.0
1200	76	TC	-	53.3	53.3	-	51.5	51.5	-	49.2	49.2	-	45.9	45.9
		SHC	-	20.8	27.4	-	20.2	26.8	-	19.3	25.7	-	18.3	24.6
1400	58	TC	41.9	41.9	47.3	40.1	40.1	45.3	38.2	38.2	43.2	36.3	36.3	41.0
		SHC	36.6	41.9	47.3	35.0	40.1	45.3	33.3	38.2	43.2	31.7	36.3	41.0
1400	62	TC	44.6	44.6	45.4	42.3	42.3	44.2	39.8	39.8	42.9	37.3	37.3	41.6
		SHC	33.4	39.4	45.4	32.3	38.3	44.2	31.0	37.0	42.9	29.8	35.7	41.6
1400	67	TC	48.7	48.7	48.7	46.6	46.6	46.6	44.2	44.2	44.2	41.4	41.4	41.4
		SHC	27.3	33.2	39.2	26.4	32.3	38.3	25.3	31.3	37.3	24.2	30.2	36.2
1400	72	TC	52.2	52.2	52.2	50.3	50.3	50.3	47.8	47.8	47.8	44.8	44.8	44.8
		SHC	20.6	26.7	32.7	19.9	25.9	32.0	18.9	24.9	30.9	17.9	23.8	29.7
1400	76	TC	-	54.1	54.1	-	52.3	52.3	-	49.9	49.9	-	46.4	46.4
		SHC	-	21.5	29.0	-	20.8	28.0	-	19.9	26.9	-	18.8	25.7
1600	58	TC	44.0	44.0	49.6	42.1	42.1	47.4	40.1	40.1	45.2	38.1	38.1	43.0
		SHC	38.3	44.0	49.6	36.7	42.1	47.4	34.9	40.1	45.2	33.2	38.1	43.0
1600	62	TC	45.7	45.7	48.6	43.5	43.5	47.5	41.0	41.0	46.0	38.5	38.5	44.4
		SHC	35.3	42.0	48.6	34.2	40.8	47.5	32.9	39.4	46.0	31.6	38.0	44.4
1600	67	TC	49.8	49.8	49.8	47.6	47.6	47.6	45.1	45.1	45.1	42.3	42.3	42.3
		SHC	28.4	35.0	41.6	27.6	34.2	40.9	26.5	33.2	39.9	25.4	32.1	38.7
1600	72	TC	53.0	53.0	53.0	51.1	51.1	51.1	48.6	48.6	48.6	45.4	45.4	45.4
		SHC	21.0	27.6	34.3	20.3	27.0	33.6	19.4	26.0	32.6	18.3	24.8	31.3
1600	76	TC	-	54.6	54.6	-	52.8	52.8	-	50.4	50.4	-	46.8	46.8
		SHC	-	22.0	29.9	-	21.3	29.0	-	20.3	27.9	-	19.2	26.6
1800	58	TC	44.0	44.0	50.3	42.1	42.1	48.1	40.1	40.1	45.9	38.0	38.0	43.5
		SHC	37.6	44.0	50.3	36.0	42.1	48.1	34.3	40.1	45.9	32.6	38.0	43.5
1800	62	TC	45.7	45.7	49.5	43.5	43.5	48.3	41.0	41.0	46.8	38.4	38.4	45.2
		SHC	34.5	42.0	49.5	33.4	40.8	48.3	32.1	39.4	46.8	30.8	38.0	45.2
1800	67	TC	49.8	49.8	49.8	47.6	47.6	47.6	45.1	45.1	45.1	42.3	42.3	42.3
		SHC	27.6	35.0	42.5	26.8	34.2	41.7	25.7	33.2	40.7	24.6	32.1	39.5
1800	72	TC	53.0	53.0	53.0	51.1	51.1	51.1	48.6	48.6	48.6	45.4	45.4	45.4
		SHC	20.2	27.6	35.1	19.5	27.0	34.4	18.5	26.0	33.4	17.5	24.8	32.1
1800	76	TC	-	54.6	54.6	-	52.8	52.8	-	50.4	50.4	-	46.8	46.8
		SHC	-	22.0	30.9	-	21.3	30.0	-	20.3	28.9	-	19.2	27.5
2000	58	TC	46.9	46.9	52.9	45.0	45.0	50.8	42.9	42.9	48.4	40.7	40.7	45.9
		SHC	40.9	46.9	52.9	39.3	45.0	50.8	37.4	42.9	48.4	35.5	40.7	45.9
2000	62	TC	47.5	47.5	54.0	45.3	45.3	52.5	43.0	43.0	50.3	40.7	40.7	47.7
		SHC	38.5	46.3	54.0	37.3	44.9	52.5	35.6	43.0	50.3	33.8	40.7	47.7
2000	67	TC	51.2	51.2	51.2	49.1	49.1	49.1	46.5	46.5	46.5	43.5	43.5	43.5
		SHC	30.5	38.3	46.0	29.8	37.6	45.5	28.7	36.6	44.5	27.5	35.4	43.2
2000	72	TC	54.0	54.0	54.0	52.1	52.1	52.1	49.7	49.7	49.7	46.2	46.2	46.2
		SHC	21.7	29.2	36.8	21.1	28.7	36.4	20.1	27.8	35.4	18.9	26.4	33.9
2000	76	TC	-	55.2	55.2	-	53.5	53.5	-	51.0	51.0	-	47.3	47.3
		SHC	-	22.7	31.4	-	22.0	30.6	-	21.1	29.6	-	19.9	28.1

**LEGEND:**

- Do not operate
- Cfm - Cubic feet per minute (supply air)
- EAT(db) - Entering air temperature (dry bulb)
- EAT(wb) - Entering air temperature (wet bulb)
- SHC - Sensible heat capacity
- TC - Total cooling capacity

4 TONS – UNIT WITH HOT GAS REHEAT SYSTEM IN SUBCOOLING MODE										
Air Entering Evaporator – CFM										
Temp (F) Air Ent Condenser (Edb)		80 dry bulb 72 wet bulb			80 dry bulb 67 wet bulb			80 dry bulb 62 wet bulb		
		1200	1600	2000	1200	1600	2000	1200	1600	2000
		75	TC	52.5	55.9	58.6	47.1	50.2	52.7	41.7
SHC	22.6		25.5	27.8	27.1	29.9	32.0	31.6	34.2	36.2
kW	2.5		2.5	2.5	2.5	2.5	2.5	2.5	2.5	2.5
85	TC	48.7	52.2	54.9	43.4	46.5	49.0	38.0	40.8	43.1
	SHC	18.0	21.3	23.9	23.6	26.8	29.2	29.3	32.2	34.4
	kW	2.9	2.9	2.9	2.9	2.9	2.9	2.9	2.9	2.9
95	TC	44.9	48.4	51.2	39.6	42.8	45.3	34.3	37.1	39.4
	SHC	13.4	17.2	20.0	20.2	23.7	26.4	27.0	30.2	32.7
	kW	3.4	3.4	3.4	3.3	3.3	3.3	3.3	3.3	3.3
105	TC	41.1	44.7	47.5	35.9	39.1	41.7	30.6	33.5	35.8
	SHC	8.8	13.0	16.1	16.7	20.6	23.6	24.6	28.2	31.0
	kW	3.8	3.8	3.8	3.7	3.7	3.7	3.7	3.7	3.7
115	TC	37.4	41.0	43.9	32.1	35.4	38.0	26.8	29.8	32.1
	SHC	4.3	8.8	12.2	13.3	17.5	20.7	22.3	26.2	29.2
	kW	4.2	4.2	4.2	4.2	4.2	4.2	4.1	4.1	4.1

4 TONS – UNIT WITH HOT GAS REHEAT SYSTEM IN HOT GAS REHEAT MODE										
Air Entering Evaporator – CFM										
Temp (F) Air Ent Condenser (Edb)		75 dry bulb 62.5 wet bulb (50% relative)			75 dry bulb 64 wet bulb (55% relative)			75 dry bulb 65.3 wet bulb (60% relative)		
		1200	1600	2000	1200	1600	2000	1200	1600	2000
		80	TC	11.6	13.8	15.5	13.5	15.8	17.6	15.2
SHC	-1.0		1.2	3.0	-3.1	-0.8	0.9	-4.8	-2.6	-0.9
kW	2.5		2.5	2.5	2.5	2.5	2.5	2.5	2.5	2.5
75	TC	12.5	14.6	16.2	14.3	16.4	18.1	15.9	18.1	19.8
	SHC	-0.7	1.4	3.0	-2.7	-0.6	1.1	-4.3	-2.2	-0.6
	kW	2.5	2.5	2.5	2.5	2.5	2.5	2.5	2.5	2.5
70	TC	13.4	15.3	16.8	15.1	17.1	18.7	16.6	18.7	20.3
	SHC	-0.5	1.5	3.0	-2.3	-0.3	1.2	-3.8	-1.9	-0.3
	kW	2.5	2.5	2.5	2.5	2.5	2.5	2.5	2.5	2.5
60	TC	15.1	16.8	18.1	16.7	18.4	19.8	18.1	19.9	21.2
	SHC	0.0	1.7	3.1	-1.5	0.2	1.5	-2.8	-1.1	0.2
	kW	2.6	2.6	2.6	2.6	2.6	2.6	2.6	2.6	2.6
50	TC	16.9	18.3	19.4	18.3	19.8	20.9	19.6	21.0	22.2
	SHC	0.6	2.0	3.1	-0.7	0.7	1.8	-1.8	-0.4	0.7
	kW	2.6	2.6	2.6	2.6	2.6	2.6	2.6	2.6	2.6
40	TC	18.7	19.8	20.7	19.9	21.1	22.0	21.0	22.2	23.2
	SHC	1.1	2.2	3.1	0.1	1.2	2.1	-0.8	0.4	1.3
	kW	2.6	2.6	2.6	2.7	2.7	2.7	2.7	2.7	2.7

**LEGEND**

- Edb – Entering Dry-Bulb
- Ewb – Entering Wet-Bulb
- kW – Compressor Motor Power Input
- ldb – Leaving Dry-Bulb
- lwb – Leaving Wet-Bulb
- SHC – Sensible Heat Capacity (1000 Btuh) Gross
- TC – Total Capacity (1000 Btuh) Gross

**NOTES:**

- 6. Direct interpolation is permissible. Do not extrapolate.
- 7. The following formulas may be used:

$$t_{ldb} = t_{edb} - \frac{\text{sensible capacity (Btuh)}}{1.10 \times \text{cfm}}$$

$t_{lwb}$  = Wet-bulb temperature corresponding to enthalpy of air leaving evaporator coil ( $h_{lwb}$ )

$$h_{lwb} = h_{ewb} - \frac{\text{total capacity (Btuh)}}{4.5 \times \text{cfm}}$$

Where:  $h_{ewb}$  = Enthalpy of air entering evaporator coil



**Table 17 – COOLING CAPACITIES – 1 STAGE – 5 TONS**

RGS060			AMBIENT TEMPERATURE												
			85			95			105			115			
			EAT (db)			EAT (db)			EAT (db)			EAT (db)			
			75	80	85	75	80	85	75	80	85	75	80	85	
1500 Cfm	EAT (wb)	58	TC	52.9	52.9	60.0	49.9	49.9	56.6	46.6	46.6	52.9	43.1	43.1	48.9
			SHC	45.8	52.9	60.0	43.2	49.9	56.6	40.4	46.6	52.9	37.3	43.1	48.9
		62	TC	56.2	56.2	57.6	52.2	52.2	55.7	47.8	47.8	53.5	43.2	43.2	51.0
			SHC	41.8	49.7	57.6	39.9	47.8	55.7	37.8	45.6	53.5	35.5	43.2	51.0
		67	TC	62.4	62.4	62.4	58.8	58.8	58.8	54.4	54.4	54.4	49.5	49.5	49.5
		SHC	34.8	42.8	50.7	33.2	41.2	49.1	31.4	39.3	47.3	29.4	37.3	45.3	
	72	TC	68.2	68.2	68.2	64.8	64.8	64.8	60.8	60.8	60.8	56.2	56.2	56.2	
		SHC	27.2	35.2	43.2	25.9	33.9	41.9	24.4	32.4	40.4	22.6	30.6	38.6	
	76	TC	-	71.1	71.1	-	69.0	69.0	-	65.4	65.4	-	60.9	60.9	
		SHC	-	28.4	36.6	-	27.6	35.9	-	26.3	34.6	-	24.8	33.0	
1750 Cfm	EAT (wb)	58	TC	56.5	56.5	64.0	53.3	53.3	60.4	49.8	49.8	56.5	46.1	46.1	52.3
			SHC	48.9	56.5	64.0	46.1	53.3	60.4	43.1	49.8	56.5	39.9	46.1	52.3
		62	TC	58.5	58.5	63.4	54.4	54.4	61.3	49.9	49.9	58.9	46.1	46.1	54.4
			SHC	45.2	54.3	63.4	43.2	52.2	61.3	41.0	49.9	58.9	37.9	46.1	54.4
		67	TC	64.3	64.3	64.3	60.5	60.5	60.5	56.2	56.2	56.2	51.3	51.3	51.3
		SHC	36.9	46.1	55.2	35.3	44.5	53.7	33.6	42.8	51.9	31.6	40.8	49.9	
	72	TC	69.5	69.5	69.5	66.5	66.5	66.5	62.4	62.4	62.4	57.7	57.7	57.7	
		SHC	27.8	36.9	45.9	26.7	35.9	45.1	25.2	34.5	43.7	23.5	32.8	42.0	
	76	TC	-	72.2	72.2	-	70.1	70.1	-	66.6	66.6	-	-	-	
		SHC	-	29.3	38.9	-	28.6	38.2	-	27.4	36.8	-	-	-	
2000 Cfm	EAT (wb)	58	TC	59.3	59.3	67.3	56.1	56.1	63.6	52.5	52.5	59.5	48.6	48.6	55.1
			SHC	51.4	59.3	67.3	48.6	56.1	63.6	45.4	52.5	59.5	42.1	48.6	55.1
		62	TC	60.1	60.1	68.5	56.2	56.2	66.3	52.5	52.5	62.0	48.7	48.7	57.4
			SHC	48.1	58.3	68.5	46.2	56.2	66.3	43.1	52.5	62.0	39.9	48.7	57.4
		67	TC	65.7	65.7	65.7	61.9	61.9	61.9	57.5	57.5	57.5	52.6	52.6	54.4
		SHC	38.8	49.1	59.5	37.3	47.7	58.1	35.6	46.0	56.4	33.6	44.0	54.4	
	72	TC	70.1	70.1	70.1	67.6	67.6	67.6	63.6	63.6	63.6	58.9	58.9	58.9	
		SHC	28.3	38.1	48.0	27.4	37.7	48.0	26.0	36.4	46.7	24.3	34.7	45.2	
	76	TC	-	72.9	72.9	-	70.8	70.8	-	67.4	67.4	-	-	-	
		SHC	-	30.1	40.7	-	29.3	39.9	-	28.2	38.7	-	-	-	
2250 Cfm	EAT (wb)	58	TC	61.5	61.5	69.8	58.4	58.4	66.2	54.8	54.8	62.1	50.8	50.8	57.6
			SHC	53.2	61.5	69.8	50.5	58.4	66.2	47.4	54.8	62.1	43.9	50.8	57.6
		62	TC	61.6	61.6	72.6	58.4	58.4	68.9	54.8	54.8	64.6	50.8	50.8	59.9
			SHC	50.6	61.6	72.6	47.9	58.4	68.9	45.0	54.8	64.6	41.7	50.8	59.9
		67	TC	66.8	66.8	66.8	63.0	63.0	63.0	58.5	58.5	60.6	53.6	53.6	58.6
		SHC	40.5	52.0	63.4	39.1	50.7	62.3	37.4	49.0	60.6	35.5	47.0	58.6	
	72	TC	70.8	70.8	70.8	68.5	68.5	68.5	64.5	64.5	64.5	59.8	59.8	59.8	
		SHC	28.7	39.5	50.2	28.0	39.3	50.5	26.7	38.1	49.6	25.0	36.6	48.1	
	76	TC	-	73.4	73.4	-	71.2	71.2	-	67.9	67.9	-	-	-	
		SHC	-	30.7	42.1	-	30.0	41.4	-	28.9	40.4	-	-	-	
2500 Cfm	EAT (wb)	58	TC	63.3	63.3	71.8	60.1	60.1	68.2	56.5	56.5	64.1	52.6	52.6	59.6
			SHC	54.8	63.3	71.8	52.1	60.1	68.2	49.0	56.5	64.1	45.5	52.6	59.6
		62	TC	63.4	63.4	74.7	60.2	60.2	71.0	56.6	56.6	66.7	52.6	52.6	62.1
			SHC	52.0	63.4	74.7	49.4	60.2	71.0	46.5	56.6	66.7	43.2	52.6	62.1
		67	TC	67.6	67.6	67.6	63.8	63.8	66.2	59.3	59.3	64.6	54.4	54.4	62.5
		SHC	42.1	54.6	67.1	40.9	53.5	66.2	39.2	51.9	64.6	37.2	49.8	62.5	
	72	TC	71.3	71.3	71.3	69.0	69.0	69.0	65.1	65.1	65.1	60.4	60.4	60.4	
		SHC	29.1	40.7	52.2	28.5	40.7	52.9	27.3	39.7	52.2	25.7	38.3	50.9	
	76	TC	-	73.8	73.8	-	71.4	71.4	-	68.3	68.3	-	-	-	
		SHC	-	31.2	43.3	-	30.5	42.6	-	29.6	41.9	-	-	-	

**LEGEND:**

- Do not operate
- Cfm - Cubic feet per minute (supply air)
- EAT(db) - Entering air temperature (dry bulb)
- EAT(wb) - Entering air temperature (wet bulb)
- SHC - Sensible heat capacity
- TC - Total cooling capacity

5 TONS – UNIT WITH HOT GAS REHEAT SYSTEM IN SUBCOOLING MODE										
Air Entering Evaporator – CFM										
Temp (F) Air Ent Condenser (Edb)		80 dry bulb 72 wet bulb			80 dry bulb 67 wet bulb			80 dry bulb 62 wet bulb		
		1750	2000	2250	1750	2000	2250	1750	2000	2250
		75	TC	73.1	78.7	84.5	63.2	66.9	70.8	53.2
SHC	35.3		37.2	38.8	42.0	43.7	45.3	48.7	50.3	51.8
kW	3.3		3.3	3.3	3.3	3.3	3.3	3.3	3.3	3.3
85	TC	67.6	71.2	75.0	59.1	61.2	63.3	50.6	51.1	51.5
	SHC	27.9	30.0	31.9	36.3	38.3	40.1	44.8	46.6	48.2
	kW	3.8	3.8	3.8	3.8	3.8	3.8	3.8	3.8	3.8
95	TC	62.1	63.8	65.5	55.1	55.4	55.8	48.0	47.0	46.0
	SHC	20.5	22.9	24.9	30.7	32.9	34.8	40.9	42.9	44.7
	kW	4.3	4.3	4.3	4.3	4.3	4.3	4.3	4.3	4.3
105	TC	56.6	56.3	56.0	51.0	49.6	48.3	45.4	43.0	40.5
	SHC	13.1	15.7	18.0	25.0	27.5	29.6	36.9	39.2	41.2
	kW	4.8	4.8	4.8	4.8	4.8	4.8	4.7	4.7	4.7
115	TC	51.1	48.8	46.5	46.9	43.9	40.7	42.8	39.0	35.0
	SHC	5.8	8.6	11.0	19.4	22.0	24.4	33.0	35.5	37.7
	kW	5.3	5.3	5.3	5.3	5.3	5.3	5.2	5.2	5.2

5 TONS – UNIT WITH HOT GAS REHEAT SYSTEM IN HOT GAS REHEAT MODE										
Air Entering Evaporator – CFM										
Temp (F) Air Ent Condenser (Edb)		75 dry bulb 62.5 wet bulb (50% relative)			75 dry bulb 64 wet bulb (55% relative)			75 dry bulb 65.3 wet bulb (60% relative)		
		1750	2000	2250	1750	2000	2250	1750	2000	2250
		80	TC	23.0	24.4	25.6	24.7	26.2	27.4	26.3
SHC	5.3		6.1	6.8	3.2	4.0	4.7	1.4	2.2	2.9
kW	2.9		2.9	2.9	2.9	2.9	2.9	2.9	2.9	2.9
75	TC	23.3	24.6	25.7	25.0	26.3	27.5	26.4	27.8	29.0
	SHC	5.1	5.8	6.5	3.1	3.9	4.5	1.4	2.2	2.8
	kW	2.9	2.9	2.9	2.9	2.9	2.9	2.9	2.9	2.9
70	TC	23.5	24.8	25.9	25.2	26.4	27.5	26.6	27.9	29.0
	SHC	4.8	5.5	6.2	3.0	3.7	4.3	1.4	2.1	2.8
	kW	3.0	3.0	3.0	3.0	3.0	3.0	3.0	3.0	3.0
60	TC	24.1	25.2	26.1	25.6	26.7	27.7	26.9	28.0	29.0
	SHC	4.3	5.0	5.5	2.8	3.4	3.9	1.4	2.0	2.6
	kW	3.0	3.0	3.0	3.0	3.0	3.0	3.0	3.0	3.0
50	TC	24.7	25.6	26.4	26.1	27.0	27.8	27.2	28.2	29.0
	SHC	3.8	4.4	4.8	2.5	3.1	3.5	1.4	2.0	2.4
	kW	3.1	3.1	3.1	3.1	3.1	3.1	3.1	3.1	3.1
40	TC	25.3	26.0	26.7	26.5	27.3	27.9	27.6	28.3	29.0
	SHC	3.3	3.8	4.2	2.3	2.8	3.1	1.4	1.9	2.3
	kW	3.1	3.1	3.1	3.2	3.2	3.2	3.2	3.2	3.2

**LEGEND**

- Edb – Entering Dry-Bulb
- Ewb – Entering Wet-Bulb
- kW – Compressor Motor Power Input
- ldb – Leaving Dry-Bulb
- lwb – Leaving Wet-Bulb
- SHC – Sensible Heat Capacity (1000 Btuh) Gross
- TC – Total Capacity (1000 Btuh) Gross

**NOTES:**

- 8. Direct interpolation is permissible. Do not extrapolate.
- 9. The following formulas may be used:

$$t_{ldb} = t_{edb} - \frac{\text{sensible capacity (Btuh)}}{1.10 \times \text{cfm}}$$

$t_{lwb}$  = Wet-bulb temperature corresponding to enthalpy of air leaving evaporator coil ( $h_{lwb}$ )

$$h_{lwb} = h_{ewb} - \frac{\text{total capacity (Btuh)}}{4.5 \times \text{cfm}}$$

Where:  $h_{ewb}$  = Enthalpy of air entering evaporator coil

**Table 19 – COOLING CAPACITIES – 1 STAGE – 6 TONS**

RGS072			AMBIENT TEMPERATURE											
			85			95			105			115		
			EAT (db)			EAT (db)			EAT (db)			EAT (db)		
			75	80	85	75	80	85	75	80	85	75	80	85
1800 Cfm	EAT (wb)	58 TC	64.9	64.9	73.3	62.1	62.1	70.0	58.9	58.9	66.4	55.6	55.6	62.7
		SHC	56.6	64.9	73.3	54.1	62.1	70.0	51.4	58.9	66.4	48.5	55.6	62.7
		62 TC	68.7	68.7	70.3	64.9	64.9	68.5	60.8	60.8	66.4	56.4	56.4	64.0
		SHC	51.7	61.0	70.3	49.9	59.2	68.5	47.9	57.2	66.4	45.7	54.9	64.0
		67 TC	75.6	75.6	75.6	71.7	71.7	71.7	67.4	67.4	67.4	62.5	62.5	62.5
	SHC	42.8	52.2	61.5	41.2	50.5	59.8	39.3	48.6	58.0	37.2	46.5	55.8	
	72 TC	82.6	82.6	82.6	78.5	78.5	78.5	73.7	73.7	73.7	67.8	67.8	67.8	
	SHC	33.5	42.8	52.2	31.9	41.3	50.6	30.0	39.3	48.6	27.8	36.9	45.9	
	76 TC	-	87.5	87.5	-	83.3	83.3	-	77.7	77.7	-	70.9	70.9	
	SHC	-	35.0	44.9	-	33.5	43.4	-	31.6	41.5	-	29.3	39.1	
2100 Cfm	EAT (wb)	58 TC	68.9	68.9	77.7	65.9	65.9	74.3	62.5	62.5	70.5	58.7	58.7	66.2
		SHC	60.1	68.9	77.7	57.4	65.9	74.3	54.5	62.5	70.5	51.2	58.7	66.2
		62 TC	70.9	70.9	76.9	67.1	67.1	75.0	63.0	63.0	72.5	58.7	58.7	68.7
		SHC	55.6	66.3	76.9	53.8	64.4	75.0	51.6	62.1	72.5	48.7	58.7	68.7
		67 TC	77.8	77.8	77.8	73.7	73.7	73.7	69.2	69.2	69.2	64.0	64.0	64.0
	SHC	45.4	56.1	66.8	43.7	54.4	65.2	41.8	52.5	63.2	39.6	50.2	60.7	
	72 TC	84.5	84.5	84.5	80.3	80.3	80.3	75.1	75.1	75.1	68.8	68.8	68.8	
	SHC	34.5	45.2	55.9	32.9	43.5	54.2	30.9	41.4	52.0	28.5	38.7	48.9	
	76 TC	-	89.2	89.2	-	84.7	84.7	-	78.8	78.8	-	71.6	71.6	
	SHC	-	36.3	47.8	-	34.7	46.0	-	32.6	43.7	-	30.1	40.9	
2400 Cfm	EAT (wb)	58 TC	72.0	72.0	81.2	68.7	68.7	77.5	65.2	65.2	73.5	61.1	61.1	68.9
		SHC	62.8	72.0	81.2	60.0	68.7	77.5	56.9	65.2	73.5	53.3	61.1	68.9
		62 TC	72.8	72.8	82.8	68.9	68.9	80.7	65.2	65.2	76.4	61.2	61.2	71.6
		SHC	59.1	71.0	82.8	57.2	68.9	80.7	54.1	65.2	76.4	50.7	61.2	71.6
		67 TC	79.4	79.4	79.4	75.2	75.2	75.2	70.5	70.5	70.5	65.1	65.1	65.3
	SHC	47.7	59.8	71.8	46.0	58.1	70.2	44.0	56.0	68.1	41.6	53.5	65.3	
	72 TC	86.0	86.0	86.0	81.6	81.6	81.6	76.1	76.1	76.1	69.6	69.6	69.6	
	SHC	35.3	47.2	59.2	33.7	45.6	57.5	31.7	43.3	55.0	29.1	40.3	51.4	
	76 TC	-	90.3	90.3	-	85.7	85.7	-	79.6	79.6	-	72.1	72.1	
	SHC	-	37.3	49.8	-	35.6	48.0	-	33.5	45.6	-	30.8	42.5	
2700 Cfm	EAT (wb)	58 TC	60.3	60.3	74.1	71.1	71.1	80.2	67.4	67.4	76.0	63.0	63.0	71.1
		SHC	46.4	60.3	74.1	62.0	71.1	80.2	58.8	67.4	76.0	55.0	63.0	71.1
		62 TC	65.4	65.4	69.3	71.2	71.2	83.3	67.5	67.5	79.0	63.1	63.1	73.8
		SHC	41.0	55.1	69.3	59.0	71.2	83.3	55.9	67.5	79.0	52.3	63.1	73.8
		67 TC	72.7	72.7	72.7	76.3	76.3	76.3	71.5	71.5	72.6	65.8	65.8	69.4
	SHC	33.8	48.0	62.2	48.2	61.6	74.9	46.1	59.3	72.6	43.5	56.5	69.4	
	72 TC	79.7	79.7	79.7	82.5	82.5	82.5	76.9	76.9	76.9	70.1	70.1	70.1	
	SHC	25.8	40.2	54.6	34.5	47.5	60.5	32.3	45.0	57.7	29.7	41.7	53.8	
	76 TC	-	85.1	85.1	-	86.4	86.4	-	80.2	80.2	-	72.5	72.5	
	SHC	-	33.5	48.4	-	36.5	49.9	-	34.3	47.3	-	31.5	44.0	
3000 Cfm	EAT (wb)	58 TC	64.9	64.9	78.8	73.1	73.1	82.5	69.2	69.2	78.0	64.5	64.5	72.7
		SHC	51.1	64.9	78.8	63.8	73.1	82.5	60.3	69.2	78.0	56.2	64.5	72.7
		62 TC	68.7	68.7	76.5	73.2	73.2	85.7	69.2	69.2	81.0	64.5	64.5	75.5
		SHC	45.5	61.0	76.5	60.7	73.2	85.7	57.4	69.2	81.0	53.5	64.5	75.5
		67 TC	75.6	75.6	75.6	77.2	77.2	79.4	72.2	72.2	76.8	66.3	66.3	73.0
	SHC	36.6	52.2	67.7	50.2	64.8	79.4	48.0	62.4	76.8	45.1	59.1	73.0	
	72 TC	82.6	82.6	82.6	83.3	83.3	83.3	77.5	77.5	77.5	70.5	70.5	70.5	
	SHC	27.2	42.8	58.5	35.1	49.2	63.3	32.9	46.6	60.3	30.2	43.0	55.9	
	76 TC	-	87.5	87.5	-	86.9	86.9	-	80.6	80.6	-	72.8	72.8	
	SHC	-	35.0	51.5	-	37.3	51.6	-	35.0	48.9	-	32.1	45.3	

**LEGEND:**

- Do not operate in this region
- Cfm - Cubic feet per minute (supply air)
- EAT(db) - Entering air temperature (dry bulb)
- EAT(wb) - Entering air temperature (wet bulb)
- SHC - Sensible heat capacity
- TC - Total cooling capacity

6 TONS – UNIT WITH HOT GAS REHEAT SYSTEM IN SUBCOOLING MODE										
Air Entering Evaporator – CFM										
Temp (F) Air Ent Condenser (Edb)		80 dry bulb 72 wet bulb			80 dry bulb 67 wet bulb			80 dry bulb 62 wet bulb		
		2100	2400	2700	2100	2400	2700	2100	2400	2700
		75	TC	86.7	89.9	92.8	79.3	82.3	84.9	71.9
SHC	40.1		41.8	43.3	46.9	48.5	49.9	53.7	55.2	56.5
kW	4.3		4.3	4.3	4.2	4.2	4.2	4.2	4.2	4.2
85	TC	79.5	82.6	85.4	72.5	75.3	77.9	65.4	68.0	70.3
	SHC	32.1	34.0	35.7	40.7	42.5	44.1	49.4	51.0	52.5
	kW	5.0	5.0	5.0	5.0	5.0	5.0	4.9	4.9	4.9
95	TC	72.4	75.3	78.1	65.6	68.3	70.8	58.8	61.3	63.6
	SHC	24.1	26.3	28.1	34.6	36.6	38.3	45.1	46.9	48.5
	kW	5.8	5.8	5.8	5.7	5.7	5.7	5.6	5.6	5.6
105	TC	65.2	68.1	70.7	58.7	61.4	63.8	52.3	54.7	56.8
	SHC	16.2	18.5	20.5	28.5	30.6	32.6	40.7	42.8	44.6
	kW	6.5	6.5	6.5	6.4	6.4	6.4	6.3	6.3	6.3
115	TC	58.0	60.8	63.3	51.9	54.4	56.7	45.7	48.0	50.1
	SHC	8.2	10.7	13.0	22.3	24.7	26.8	36.4	38.6	40.6
	kW	7.2	7.2	7.2	7.1	7.1	7.1	7.0	7.0	7.0

6 TONS – UNIT WITH HOT GAS REHEAT SYSTEM IN HOT GAS REHEAT MODE										
Air Entering Evaporator – CFM										
Temp (F) Air Ent Condenser (Edb)		75 dry bulb 62.5 wet bulb (50% relative)			75 dry bulb 64 wet bulb (55% relative)			75 dry bulb 65.3 wet bulb (60% relative)		
		2100	2400	2700	2100	2400	2700	1750	2000	2700
		80	TC	16.7	19.8	22.5	18.8	21.9	24.7	16.2
SHC	0.6		0.6	0.6	-0.4	-0.4	-0.4	-1.3	-1.3	-1.3
kW	4.0		4.0	4.0	4.0	4.0	4.0	4.0	4.0	4.0
75	TC	17.7	20.6	23.1	19.6	22.6	25.3	17.3	20.3	27.1
	SHC	0.6	0.6	0.6	-0.3	-0.3	-0.3	-1.2	-1.2	-1.2
	kW	4.0	4.0	4.0	4.0	4.0	4.0	4.0	4.0	4.0
70	TC	18.6	21.3	23.7	20.5	23.3	25.8	18.3	21.1	27.6
	SHC	0.7	0.7	0.7	-0.2	-0.2	-0.2	-1.0	-1.0	-1.0
	kW	4.0	4.0	4.0	4.1	4.1	4.1	4.1	4.1	4.1
60	TC	20.5	22.9	25.0	22.2	24.7	26.8	20.4	22.8	28.5
	SHC	0.7	0.7	0.7	-0.0	-0.0	-0.0	-0.7	-0.7	-0.7
	kW	4.1	4.1	4.1	4.1	4.1	4.1	4.1	4.1	4.1
50	TC	22.4	24.4	26.2	24.0	26.0	27.9	22.4	24.5	29.3
	SHC	0.8	0.8	0.8	0.1	0.1	0.1	-0.4	-0.4	-0.4
	kW	4.1	4.1	4.1	4.1	4.1	4.1	4.2	4.2	4.2
40	TC	24.3	25.9	27.4	25.7	27.4	28.9	24.5	26.3	30.2
	SHC	0.8	0.8	0.8	0.3	0.3	0.3	-0.1	-0.1	-0.1
	kW	4.1	4.1	4.1	4.2	4.2	4.2	4.2	4.2	4.2

**LEGEND**

- Edb – Entering Dry-Bulb
- Ewb – Entering Wet-Bulb
- kW – Compressor Motor Power Input
- ldb – Leaving Dry-Bulb
- lwb – Leaving Wet-Bulb
- SHC – Sensible Heat Capacity (1000 Btuh) Gross
- TC – Total Capacity (1000 Btuh) Gross

**NOTES:**

- 10. Direct interpolation is permissible. Do not extrapolate.
- 11. The following formulas may be used:

$$t_{ldb} = t_{edb} - \frac{\text{sensible capacity (Btuh)}}{1.10 \times \text{cfm}}$$

$t_{lwb}$  = Wet-bulb temperature corresponding to enthalpy of air leaving evaporator coil ( $h_{lwb}$ )

$$h_{lwb} = h_{ewb} - \frac{\text{total capacity (Btuh)}}{4.5 \times \text{cfm}}$$

Where:  $h_{ewb}$  = Enthalpy of air entering evaporator coil

**Table 21 – COOLING CAPACITIES – 1 STAGE – 7.5 TONS**

RGS091			AMBIENT TEMPERATURE												
			85			95			105			115			
			EAT (db)			EAT (db)			EAT (db)			EA (db)			
			75	80	85	75	80	85	75	80	85	75	80	85	
2250 Cfm	EAT (wb)	58	TC	81.2	81.2	91.8	77.5	77.5	87.7	73.6	73.6	83.3	69.5	69.5	78.7
			SHC	70.5	81.2	91.8	67.3	77.5	87.7	63.9	73.6	83.3	60.4	69.5	78.7
		62	TC	86.9	86.9	86.9	82.3	82.3	84.0	77.2	77.2	81.5	71.9	71.9	78.8
			SHC	63.6	74.9	86.2	61.4	72.7	84.0	58.9	70.2	81.5	56.3	67.6	78.8
		67	TC	95.2	95.2	95.2	90.7	90.7	90.7	85.7	85.7	85.7	79.9	79.9	79.9
		SHC	52.8	64.2	75.6	50.9	62.2	73.6	48.8	60.1	71.5	46.3	57.6	68.9	
	72	TC	103.5	103.5	103.5	98.9	98.9	98.9	93.8	93.8	93.8	87.3	87.3	87.3	
		SHC	41.5	53.1	64.6	39.7	51.2	62.7	37.7	49.2	60.6	35.3	46.6	57.8	
	76	TC	-	109.6	109.6	-	104.8	104.8	-	99.1	99.1	-	91.6	91.6	
		SHC	-	43.7	56.0	-	42.0	54.3	-	40.0	52.4	-	37.4	49.8	
2625 Cfm	EAT (wb)	58	TC	85.9	85.9	97.2	82.2	82.2	93.1	78.1	78.1	88.4	73.9	73.9	83.6
			SHC	74.6	85.9	97.2	71.4	82.2	93.1	67.9	78.1	88.4	64.1	73.9	83.6
		62	TC	89.6	89.6	94.1	85.1	85.1	91.7	80.1	80.1	89.1	74.6	74.6	86.0
			SHC	68.1	81.1	94.1	65.9	78.8	91.7	63.4	76.3	89.1	60.6	73.3	86.0
		67	TC	97.9	97.9	97.9	93.2	93.2	93.2	88.1	88.1	88.1	82.0	82.0	82.0
		SHC	55.7	68.7	81.7	53.7	66.7	79.8	51.6	64.6	77.6	49.0	62.0	74.9	
	72	TC	106.0	106.0	106.0	101.3	101.3	101.3	95.9	95.9	95.9	89.0	89.0	89.0	
		SHC	42.7	55.8	68.9	40.9	53.9	67.0	38.8	51.8	64.7	36.2	48.9	61.7	
	76	TC	-	111.8	111.8	-	106.9	106.9	-	100.7	100.7	-	92.7	92.7	
		SHC	-	45.3	59.8	-	43.6	58.0	-	41.4	55.6	-	38.7	52.6	
3000 Cfm	EAT (wb)	58	TC	89.6	89.6	101.4	85.9	85.9	97.2	81.7	81.7	92.5	77.0	77.0	87.1
			SHC	77.9	89.6	101.4	74.6	85.9	97.2	71.0	81.7	92.5	66.9	77.0	87.1
		62	TC	91.8	91.8	101.1	87.2	87.2	98.6	82.3	82.3	95.5	77.1	77.1	90.6
			SHC	72.2	86.7	101.1	69.9	84.3	98.6	67.2	81.3	95.5	63.5	77.1	90.6
		67	TC	99.9	99.9	99.9	95.2	95.2	95.2	89.9	89.9	89.9	83.6	83.6	83.6
		SHC	58.3	72.9	87.5	56.4	71.0	85.5	54.2	68.8	83.4	51.6	66.1	80.5	
	72	TC	107.9	107.9	107.9	103.0	103.0	103.0	97.3	97.3	97.3	90.1	90.1	90.1	
		SHC	43.7	58.3	72.8	41.9	56.4	70.9	39.7	54.1	68.4	37.0	51.0	65.0	
	76	TC	-	113.8	113.8	-	108.4	108.4	-	102.0	102.0	-	93.4	93.4	
		SHC	-	46.7	62.5	-	44.8	60.4	-	42.6	57.9	-	39.6	54.7	
3375 Cfm	EAT (wb)	58	TC	92.7	92.7	104.9	88.8	88.8	100.5	84.6	84.6	95.7	79.6	79.6	90.0
			SHC	80.5	92.7	104.9	77.1	88.8	100.5	73.4	84.6	95.7	69.1	79.6	90.0
		62	TC	93.7	93.7	107.3	89.1	89.1	104.7	84.6	84.6	99.5	79.6	79.6	93.6
			SHC	75.8	91.6	107.3	73.5	89.1	104.7	69.8	84.6	99.5	65.6	79.6	93.6
		67	TC	101.5	101.5	101.5	96.7	96.7	96.7	91.3	91.3	91.3	84.8	84.8	85.7
		SHC	60.8	76.9	93.0	58.8	74.9	91.0	56.7	72.8	88.9	53.9	69.8	85.7	
	72	TC	109.4	109.4	109.4	104.3	104.3	104.3	98.4	98.4	98.4	90.9	90.9	90.9	
		SHC	44.6	60.5	76.4	42.8	58.6	74.4	40.5	56.2	71.8	37.7	52.8	68.0	
	76	TC	-	115.1	115.1	-	109.5	109.5	-	102.8	102.8	-	94.0	94.0	
		SHC	-	47.8	64.9	-	45.9	62.7	-	43.5	60.1	-	40.4	56.5	
3750 Cfm	EAT (wb)	58	TC	95.3	95.3	107.8	91.3	91.3	103.3	86.9	86.9	98.3	81.7	81.7	92.4
			SHC	82.7	95.3	107.8	79.3	91.3	103.3	75.5	86.9	98.3	70.9	81.7	92.4
		62	TC	95.5	95.5	112.2	91.3	91.3	107.4	87.0	87.0	102.2	81.7	81.7	96.0
			SHC	78.7	95.5	112.2	75.3	91.3	107.4	71.7	87.0	102.2	67.4	81.7	96.0
		67	TC	102.8	102.8	102.8	97.9	97.9	97.9	92.3	92.3	94.0	85.7	85.7	90.5
		SHC	63.1	80.6	98.2	61.2	78.7	96.3	59.0	76.5	94.0	56.0	73.2	90.5	
	72	TC	110.6	110.6	110.6	105.4	105.4	105.4	99.2	99.2	99.2	91.5	91.5	91.5	
		SHC	45.5	62.7	79.9	43.5	60.7	77.8	41.3	58.1	75.0	38.3	54.5	70.7	
	76	TC	-	116.1	116.1	-	110.3	110.3	-	103.5	103.5	-	94.5	94.5	
		SHC	-	48.9	67.0	-	46.8	64.8	-	44.4	62.0	-	41.1	58.1	

**LEGEND:**

- Do not operate in this region
- Cfm - Cubic feet per minute (supply air)
- EAT(db) - Entering air temperature (dry bulb)
- EAT(wb) - Entering air temperature (wet bulb)
- SHC - Sensible heat capacity
- TC - Total cooling capacity

**Table 22 – COOLING CAPACITIES – 2 STAGE COOLING – 7.5 TONS**

RGS090			AMBIENT TEMPERATURE											
			85			95			105			115		
			EAT (db)			EAT (db)			EAT (db)			EA (db)		
Cfm	EAT (wb)	TC SHC	75	80	85	75	80	85	75	80	85	75	80	85
			2250	58	TC SHC	77.4 66.9	77.4 77.4	87.8 87.8	73.8 63.9	73.8 73.8	83.8 83.8	70.1 60.6	70.1 70.1	79.5 79.5
	62	TC SHC	82.2 60.8	82.2 72.4	83.9 83.9	77.5 58.6	77.5 70.1	81.7 81.7	72.6 56.3	72.6 67.7	79.2 79.2	67.3 53.6	67.3 65.0	76.4 76.4
			67	TC SHC	90.1 50.2	90.1 61.8	90.1 73.3	86.0 48.5	86.0 60.1	86.0 71.6	81.4 46.5	81.4 58.1	81.4 69.7	75.9 44.2
	72	TC SHC			98.0 39.1	98.0 50.7	98.0 62.4	94.0 37.5	94.0 49.2	94.0 60.9	89.5 35.8	89.5 47.5	89.5 59.2	84.3 33.8
				76	TC SHC	- -	104.3 41.7	104.3 54.0	- -	100.4 40.3	100.4 52.7	- -	95.9 38.7	95.9 51.0
	58	TC SHC				82.1 71.0	82.1 82.1	93.2 93.2	78.4 67.8	78.4 78.4	89.0 89.0	74.4 64.3	74.4 74.4	84.4 84.4
				62	TC SHC	84.9 65.4	84.9 78.6	91.8 91.8	80.4 63.2	80.4 76.3	89.5 89.5	75.4 60.6	75.4 73.7	86.7 86.7
	67	TC SHC				92.5 53.0	92.5 66.3	92.5 79.5	88.3 51.3	88.3 64.6	88.3 78.0	83.6 49.4	83.6 62.8	83.6 76.1
				72	TC SHC	100.4 40.2	100.4 53.5	100.4 66.7	96.4 38.7	96.4 52.0	96.4 65.3	91.7 36.9	91.7 50.3	91.7 63.7
	76	TC SHC				- -	106.5 43.3	106.5 57.6	- -	102.6 41.8	102.6 55.9	- -	98.0 40.2	98.0 54.1
				58	TC SHC	85.7 74.1	85.7 85.7	97.3 97.3	82.2 71.1	82.2 82.2	93.3 93.3	78.0 67.5	78.0 78.0	88.6 88.6
	62	TC SHC				86.9 69.3	86.9 84.0	98.7 98.7	82.8 67.2	82.8 81.8	96.4 96.4	78.2 64.1	78.2 78.2	92.3 92.3
				67	TC SHC	94.3 55.6	94.3 70.5	94.3 85.4	90.1 54.0	90.1 68.9	90.1 83.9	85.2 52.1	85.2 67.1	85.2 82.2
	72	TC SHC				102.2 41.2	102.2 56.0	102.2 70.7	98.1 39.7	98.1 54.6	98.1 69.5	93.3 38.0	93.3 53.0	93.3 68.0
				76	TC SHC	- -	108.1 44.5	108.1 60.2	- -	104.2 43.2	104.2 58.7	- -	99.5 41.6	99.5 57.0
	58	TC SHC				88.5 76.5	88.5 88.5	100.4 100.4	85.0 73.5	85.0 85.0	96.4 96.4	81.0 70.1	81.0 81.0	92 92
				62	TC SHC	88.9 72.3	88.9 88.1	103.9 103.9	85.1 69.7	85.1 85.1	100.4 100.4	81.1 66.5	81.1 81.1	95.7 95.7
	67	TC SHC				95.8 58.0	95.8 74.4	95.8 90.9	91.5 56.4	91.5 73.0	91.5 89.6	86.6 54.6	86.6 71.3	87.9 87.9
				72	TC SHC	103.6 42.0	103.6 58.3	103.6 74.5	99.4 40.6	99.4 57.0	99.4 73.4	94.6 38.9	94.6 55.5	94.6 72.0
	76	TC SHC				- -	109.2 45.6	109.2 62.6	- -	105.4 44.4	105.4 61.3	- -	100.7 42.8	100.7 59.7
				58	TC SHC	90.8 78.5	90.8 90.8	103.0 103.0	87.3 75.5	87.3 87.3	99.1 99.1	83.3 72.0	83.3 83.3	94.5 94.5
	62	TC SHC				90.9 74.5	90.9 90.9	107.2 107.2	87.4 71.6	87.4 87.4	103.1 103.1	83.3 68.3	83.3 83.3	98.4 98.4
				67	TC SHC	97.0 60.3	97.0 78.2	97.0 96.2	92.6 58.8	92.6 76.9	95.1 95.1	87.6 56.9	87.6 75.2	93.4 93.4
	72	TC SHC				104.7 42.9	104.7 60.5	104.7 78.1	100.5 41.4	100.5 59.3	100.5 77.1	95.6 39.8	95.6 57.8	95.6 75.9
				76	TC SHC	- -	110.2 46.7	110.2 64.8	- -	106.2 45.4	106.2 63.6	- -	101.6 44.0	101.6 62.3

**LEGEND:**

- Do not operate in this region
- Cfm – Cubic feet per minute (supply air)
- EAT(db) – Entering air temperature (dry bulb)
- EAT(wb) – Entering air temperature (wet bulb)
- SHC – Sensible heat capacity
- TC – Total capacity

**TABLE 23 – COOLING CAPACITIES**

**2-STAGE COOLING**

**7.5 TONS**

7.5 TON COOLING CAPACITIES, UNIT WITH HOT GAS REHEAT SYSTEM IN SUBCOOLING MODE										
TEMP (F) AIR ENT CONDENSER (Edb)		AIR ENTERING EVAPORATOR – CFM								
		2250/0.05			3000/0.07			3750/0.09		
		Air Entering Evaporator – Ewb (F)								
		72	67	62	72	67	62	72	67	62
75	TC	103.05	93.02	83.60	109.77	99.52	90.08	114.01	103.69	95.19
	SHC	43.66	55.34	67.09	50.99	66.29	81.31	57.49	76.27	92.20
	kW	4.90	4.83	4.77	4.82	4.88	4.96	4.99	4.91	4.85
85	TC	95.39	85.83	76.88	101.59	91.89	82.95	105.53	95.76	87.77
	SHC	36.42	48.47	60.60	43.24	58.99	74.40	49.44	68.68	84.90
	kW	5.49	5.42	5.36	5.40	5.47	5.54	5.58	5.50	5.44
95	TC	87.48	78.44	69.97	93.21	84.05	75.61	96.84	87.63	80.14
	SHC	28.98	41.46	53.97	35.32	51.53	67.34	41.21	60.92	77.41
	kW	6.16	6.09	6.03	6.08	6.14	6.21	6.24	6.17	6.11
105	TC	79.35	70.83	62.84	84.57	75.96	68.04	87.88	79.23	72.26
	SHC	21.34	34.26	47.18	27.17	43.86	60.08	32.73	52.95	69.70
	kW	6.93	6.86	6.81	6.85	6.91	6.97	7.00	6.93	6.88
115	TC	70.87	62.89	55.42	75.58	67.54	60.15	78.56	70.51	64.06
	SHC	13.40	26.79	40.14	18.70	35.89	52.54	23.94	44.68	61.67
	kW	7.79	7.74	7.69	7.73	7.78	7.83	7.86	7.80	7.76

7.5 TON COOLING CAPACITIES, UNIT WITH HOT GAS REHEAT SYSTEM IN HOT GAS REHEAT MODE										
TEMP (F) AIR ENT CONDENSER (Edb)		AIR ENTERING EVAPORATOR – Ewb (F)								
		75 Dry Bulb 62.5 Wet Bulb (50% Relative)			75 Dry Bulb 64 Wet Bulb (56% Relative)			75 Dry Bulb 65.3 Wet Bulb (60% Relative)		
		Air Entering Evaporator – Cfm								
		2250	3000	3750	2250	3000	3750	2250	3000	3750
80	TC	27.60	32.75	30.19	40.09	39.43	37.73	45.06	45.25	44.25
	SHC	-3.12	5.20	6.71	3.75	5.24	6.75	3.77	5.26	6.78
	kW	4.56	4.51	4.46	4.63	4.60	4.56	4.70	4.67	4.64
75	TC	35.40	33.78	31.20	41.14	40.51	38.80	46.15	46.37	45.38
	SHC	4.67	6.17	7.69	4.71	6.21	7.73	4.74	6.24	7.76
	kW	4.41	4.36	4.39	4.41	4.36	4.36	4.41	4.39	4.36
70	TC	36.36	34.71	32.18	42.10	41.47	39.77	47.08	47.31	46.32
	SHC	5.63	7.14	8.66	5.67	7.18	8.71	5.70	7.21	8.74
	kW	4.43	4.49	4.41	4.44	4.40	4.39	4.49	4.47	4.44
60	TC	38.25	36.64	34.15	43.97	43.37	41.72	48.98	49.22	48.26
	SHC	7.56	9.09	10.62	7.60	9.13	10.66	7.62	9.15	10.69
	kW	4.56	4.55	4.43	4.57	4.53	4.46	4.56	4.55	4.50
50	TC	40.15	38.60	36.14	45.95	45.37	43.73	50.57	50.97	49.56
	SHC	9.48	11.03	12.58	9.52	11.07	12.62	9.54	11.10	12.64
	kW	4.63	4.52	4.38	4.45	4.41	4.33	5.25	4.91	5.60
40	TC	42.18	40.62	38.11	47.80	47.25	45.43	52.65	52.75	51.83
	SHC	11.41	12.98	14.54	11.45	13.02	14.58	11.47	13.04	14.60
	kW	4.32	4.37	4.37	4.65	4.60	4.89	4.96	5.20	5.12

**LEGEND**

- Edb - Entering Dry-Bulb
- Ewb - Entering Wet-Bulb
- kW - Compressor Motor Power Input
- ldb - Leaving Dry-Bulb
- lwb - Leaving Wet-Bulb
- SHC - Sensible Heat Capacity (1000 Btuh) Gross
- TC - Total Capacity (1000 Btuh) Gross

**NOTES:**

- 12. Direct interpolation is permissible. Do not extrapolate.
- 13. The following formulas may be used:

$$t_{ldb} = t_{edb} - \frac{\text{sensible capacity (Btuh)}}{1.10 \times \text{cfm}}$$

t<sub>lwb</sub> = Wet-bulb temperature corresponding to enthalpy of air leaving evaporator coil (h<sub>lwb</sub>)

$$h_{lwb} = h_{ewb} - \frac{\text{total capacity (Btuh)}}{4.5 \times \text{cfm}}$$

Where: h<sub>ewb</sub> = Enthalpy of air entering evaporator coil

**Table 24 – COOLING CAPACITIES – 1 STAGE COOLING – 8.5 TONS**

RGS101			AMBIENT TEMPERATURE												
			85			95			105			115			
			EAT (db)			EAT (db)			EAT (db)			EAT (db)			
			75	80	85	75	80	85	75	80	85	75	80	85	
2550 Cfm	EAT (wb)	58	TC	88.1	88.1	99.9	84.1	84.1	95.3	79.6	79.6	90.3	74.9	74.9	84.9
			SHC	76.4	88.1	99.9	72.8	84.1	95.3	69.0	79.6	90.3	64.9	74.9	84.9
		62	TC	93.9	93.9	95.2	88.6	88.6	92.6	82.8	82.8	89.7	76.6	76.6	86.5
			SHC	69.4	82.3	95.2	66.8	79.7	92.6	64.1	76.9	89.7	61.0	73.8	86.5
		67	TC	103.8	103.8	103.8	98.7	98.7	98.7	93.0	93.0	93.0	86.7	86.7	86.7
		SHC	57.8	70.7	83.6	55.6	68.5	81.4	53.1	66.1	79.0	50.5	63.4	76.4	
	72	TC	113.1	113.1	113.1	108.0	108.0	108.0	102.4	102.4	102.4	96.1	96.1	96.1	
		SHC	45.2	58.3	71.3	43.2	56.3	69.3	41.1	54.1	67.1	38.7	51.7	64.7	
		76	TC	-	119.9	119.9	-	114.7	114.7	-	109.0	109.0	-	102.7	102.7
			SHC	-	47.9	61.9	-	46.0	60.1	-	44.1	58.1	-	41.9	55.8
2975 Cfm	EAT (wb)	58	TC	93.6	93.6	106.1	89.3	89.3	101.2	84.6	84.6	96.0	79.6	79.6	90.3
			SHC	81.1	93.6	106.1	77.4	89.3	101.2	73.3	84.6	96.0	69.0	79.6	90.3
		62	TC	97.5	97.5	104.3	92.0	92.0	101.4	86.1	86.1	98.3	79.8	79.8	94.1
			SHC	74.7	89.5	104.3	72.0	86.7	101.4	69.1	83.7	98.3	65.6	79.8	94.1
		67	TC	106.7	106.7	106.7	101.5	101.5	101.5	95.7	95.7	95.7	89.2	89.2	89.2
		SHC	61.0	75.8	90.6	58.8	73.6	88.5	56.4	71.3	86.1	53.8	68.7	83.6	
	72	TC	115.8	115.8	115.8	110.6	110.6	110.6	104.9	104.9	104.9	98.4	98.4	98.4	
		SHC	46.5	61.3	76.2	44.5	59.4	74.2	42.3	57.2	72.1	40.0	54.8	69.7	
		76	TC	-	122.4	122.4	-	117.0	117.0	-	111.1	111.1	-	104.5	104.5
			SHC	-	49.8	66.1	-	47.8	63.9	-	45.7	61.6	-	43.4	59.0
3400 Cfm	EAT (wb)	58	TC	98.1	98.1	111.3	93.7	93.7	106.2	88.9	88.9	100.8	83.7	83.7	94.9
			SHC	85.0	98.1	111.3	81.2	93.7	106.2	77.0	88.9	100.8	72.5	83.7	94.9
		62	TC	100.0	100.0	112.3	94.9	94.9	108.6	89.1	89.1	104.9	83.8	83.8	98.7
			SHC	79.3	95.8	112.3	76.3	92.5	108.6	73.2	89.1	104.9	68.8	83.8	98.7
		67	TC	109.0	109.0	109.0	103.6	103.6	103.6	97.6	97.6	97.6	91.0	91.0	91.0
		SHC	63.9	80.5	97.2	61.8	78.5	95.2	59.4	76.1	92.9	56.8	73.5	90.3	
	72	TC	117.9	117.9	117.9	112.5	112.5	112.5	106.6	106.6	106.6	100.0	100.0	100.0	
		SHC	47.6	64.1	80.6	45.6	62.1	78.7	43.4	60.0	76.6	41.1	57.6	74.2	
		76	TC	-	124.2	124.2	-	118.6	118.6	-	112.5	112.5	-	105.7	105.7
			SHC	-	51.2	69.0	-	49.2	66.7	-	47.0	64.4	-	44.7	61.9
3825 Cfm	EAT (wb)	58	TC	101.6	101.6	115.1	97.2	97.2	110.1	92.3	92.3	104.6	87.0	87.0	98.6
			SHC	88.0	101.6	115.1	84.2	97.2	110.1	80.0	92.3	104.6	75.4	87.0	98.6
		62	TC	101.9	101.9	120.0	97.3	97.3	114.6	92.4	92.4	108.9	87.1	87.1	102.6
			SHC	83.7	101.8	120.0	79.9	97.3	114.6	75.9	92.4	108.9	71.6	87.1	102.6
		67	TC	110.7	110.7	110.7	105.3	105.3	105.3	99.2	99.2	99.3	92.5	92.5	96.7
		SHC	66.7	85.0	103.4	64.6	83.0	101.5	62.2	80.8	99.3	59.6	78.2	96.7	
	72	TC	119.4	119.4	119.4	114.0	114.0	114.0	108.0	108.0	108.0	101.3	101.3	101.3	
		SHC	48.5	66.6	84.6	46.6	64.7	82.7	44.4	62.6	80.7	42.1	60.2	78.4	
		76	TC	-	125.5	125.5	-	119.8	119.8	-	113.6	113.6	-	106.7	106.7
			SHC	-	52.4	71.5	-	50.4	69.3	-	48.2	67.0	-	45.9	64.4
4250 Cfm	EAT (wb)	58	TC	104.4	104.4	118.3	99.9	99.9	113.2	95.0	95.0	107.6	89.5	89.5	101.5
			SHC	90.4	104.4	118.3	86.6	99.9	113.2	82.3	95.0	107.6	77.6	89.5	101.5
		62	TC	104.4	104.4	123.0	99.9	99.9	117.8	95.0	95.0	112.0	89.6	89.6	105.6
			SHC	85.8	104.4	123.0	82.1	99.9	117.8	78.1	95.0	112.0	73.6	89.6	105.6
		67	TC	112.1	112.1	112.1	106.6	106.6	107.5	100.4	100.4	105.3	93.6	93.6	102.7
		SHC	69.2	89.2	109.2	67.2	87.3	107.5	64.9	85.1	105.3	62.3	82.5	102.7	
	72	TC	120.7	120.7	120.7	115.1	115.1	115.1	109.0	109.0	109.0	102.2	102.2	102.2	
		SHC	49.4	68.9	88.4	47.4	67.0	86.5	45.3	64.9	84.6	42.9	62.6	82.3	
		76	TC	-	126.6	126.6	-	120.8	120.8	-	114.5	114.5	-	107.4	107.4
			SHC	-	53.5	73.9	-	51.5	71.7	-	49.3	69.4	-	46.9	66.8

**LEGEND:**

- Do not operate in this region
- Cfm - Cubic feet per minute (supply air)
- EAT(db) - Entering air temperature (dry bulb)
- EAT(wb) - Entering air temperature (wet bulb)
- SHC - Sensible heat capacity
- TC - Total cooling capacity



**Table 25 – COOLING CAPACITIES – 2 STAGE COOLING – 8.5 TONS**

RGS102			AMBIENT TEMPERATURE													
			85			95			105			115				
			EA (dB)			EA (dB)			EA (dB)			EA (dB)				
			75	80	85	75	80	85	75	80	85	75	80	85		
2550 Cfm	EAT (wb)	58	TC	89.7	89.7	101.6	85.2	85.2	96.5	79.6	79.6	90.1	73.8	73.8	83.6	
			SHC	77.8	89.7	101.6	73.9	85.2	96.5	69.0	79.6	90.1	64.0	73.8	83.6	
		62	TC	94.3	94.3	97.9	88.7	88.7	95.2	81.3	81.3	91.5	74.3	74.3	86.5	
			SHC	71.0	84.4	97.9	68.2	81.7	95.2	64.7	78.1	91.5	60.6	73.6	86.5	
		67	TC	105.0	105.0	105.0	99.3	99.3	99.3	92.2	92.2	92.2	84.1	84.1	84.1	
			SHC	59.0	72.6	86.1	56.6	70.1	83.7	53.6	67.1	80.7	50.3	63.8	77.3	
	72	TC	115.9	115.9	115.9	110.4	110.4	110.4	104.2	104.2	104.2	96.0	96.0	96.0		
		SHC	46.4	60.0	73.6	44.3	57.9	71.5	41.9	55.5	69.1	38.8	52.4	65.9		
	76	TC	-	123.7	123.7	-	118.3	118.3	-	112.4	112.4	-	105.7	105.7		
		SHC	-	49.3	63.3	-	47.3	61.4	-	45.3	59.3	-	42.9	56.7		
	2975 Cfm	EAT (wb)	58	TC	95.3	95.3	107.9	90.7	90.7	102.7	84.8	84.8	96.1	78.7	78.7	89.1
				SHC	82.6	95.3	107.9	78.6	90.7	102.7	73.5	84.8	96.1	68.2	78.7	89.1
62			TC	97.9	97.9	107.8	92.1	92.1	104.7	85.4	85.4	99.4	78.8	78.8	92.8	
			SHC	76.7	92.2	107.8	73.9	89.3	104.7	69.6	84.5	99.4	64.8	78.8	92.8	
67			TC	108.5	108.5	108.5	102.6	102.6	102.6	95.4	95.4	95.4	86.9	86.9	86.9	
			SHC	62.8	78.4	94.1	60.4	76.0	91.7	57.4	73.1	88.8	54.0	69.7	85.3	
72		TC	119.1	119.1	119.1	113.5	113.5	113.5	107.2	107.2	107.2	99.2	99.2	99.2		
		SHC	47.9	63.5	79.2	45.8	61.5	77.1	43.5	59.2	74.9	40.6	56.3	72.0		
76		TC	-	126.4	126.4	-	120.8	120.8	-	114.8	114.8	-	108.2	108.2		
		SHC	-	51.1	67.4	-	49.2	65.3	-	47.0	63.0	-	44.8	60.7		
3400 Cfm		EAT (wb)	58	TC	100.0	100.0	113.3	95.2	95.2	107.9	89.3	89.3	101.1	82.9	82.9	93.9
				SHC	86.7	100.0	113.3	82.6	95.2	107.9	77.4	89.3	101.1	71.8	82.9	93.9
	62		TC	101.1	101.1	115.8	95.7	95.7	111.7	89.4	89.4	105.3	83.0	83.0	97.7	
			SHC	81.5	98.7	115.8	78.2	94.9	111.7	73.5	89.4	105.3	68.2	83.0	97.7	
	67		TC	111.1	111.1	111.1	105.1	105.1	105.1	97.8	97.8	97.8	89.1	89.1	93.0	
			SHC	66.2	83.9	101.6	63.9	81.6	99.3	61.0	78.7	96.5	57.5	75.3	93.0	
	72	TC	121.3	121.3	121.3	115.6	115.6	115.6	109.4	109.4	109.4	101.5	101.5	101.5		
		SHC	49.2	66.7	84.3	47.1	64.7	82.3	44.9	62.5	80.2	42.1	59.9	77.7		
	76	TC	-	128.3	128.3	-	122.6	122.6	-	116.3	116.3	-	109.7	109.7		
		SHC	-	52.7	70.7	-	50.7	68.6	-	48.6	66.4	-	46.4	64.2		
	3825 Cfm	EAT (wb)	58	TC	104.0	104.0	117.8	99.1	99.1	112.3	93.2	93.2	105.5	86.5	86.5	97.9
				SHC	90.2	104.0	117.8	86.0	99.1	112.3	80.8	93.2	105.5	75.0	86.5	97.9
62			TC	104.2	104.2	122.7	99.3	99.3	116.9	93.3	93.3	109.8	86.6	86.6	101.9	
			SHC	85.7	104.2	122.7	81.7	99.3	116.9	76.7	93.3	109.8	71.2	86.6	101.9	
67			TC	113.1	113.1	113.1	107.1	107.1	107.1	99.9	99.9	103.8	91.0	91.0	100.3	
			SHC	69.4	89.1	108.8	67.1	86.8	106.5	64.3	84.1	103.8	60.9	80.6	100.3	
72		TC	123.0	123.0	123.0	117.2	117.2	117.2	110.9	110.9	110.9	103.3	103.3	103.3		
		SHC	50.3	69.7	89.0	48.3	67.7	87.1	46.1	65.6	85.2	43.5	63.3	83.0		
76		TC	-	129.7	129.7	-	124.0	124.0	-	117.5	117.5	-	110.8	110.8		
		SHC	-	54.0	73.7	-	52.1	71.7	-	50.0	69.5	-	47.8	67.4		
4250 Cfm		EAT (wb)	58	TC	107.4	107.4	121.7	102.5	102.5	116.1	96.5	96.5	109.3	89.5	89.5	101.4
				SHC	93.1	107.4	121.7	88.9	102.5	116.1	83.7	96.5	109.3	77.6	89.5	101.4
	62		TC	107.5	107.5	126.6	102.6	102.6	120.8	96.6	96.6	113.7	89.6	89.6	105.5	
			SHC	88.4	107.5	126.6	84.4	102.6	120.8	79.5	96.6	113.7	73.7	89.6	105.5	
	67		TC	114.7	114.7	115.6	108.7	108.7	113.5	101.7	101.7	110.8	92.6	92.6	107.2	
			SHC	72.5	94.0	115.6	70.2	91.8	113.5	67.5	89.2	110.8	64.0	85.6	107.2	
	72	TC	124.3	124.3	124.3	118.5	118.5	118.5	112.1	112.1	112.1	104.7	104.7	104.7		
		SHC	51.3	72.4	93.4	49.3	70.5	91.7	47.2	68.5	89.9	44.7	66.4	88.1		
	76	TC	-	130.7	130.7	-	125.0	125.0	-	118.5	118.5	-	111.6	111.6		
		SHC	-	55.3	76.5	-	53.5	74.6	-	51.3	72.4	-	49.2	70.3		

**LEGEND:**

- Do not operate in this region
- Cfm – Cubic feet per minute (supply air)
- EAT(db) – Entering air temperature (dry bulb)
- EAT(wb) – Entering air temperature (wet bulb)
- SHC – Sensible heat capacity
- TC – Total capacity

**TABLE 26 – COOLING CAPACITIES**

**2-STAGE COOLING**

**8.5 TONS**

8.5 TON COOLING CAPACITIES, UNIT WITH HOT GAS REHEAT SYSTEM IN SUBCOOLING MODE										
TEMP (F) AIR ENT CONDENSER (Edb)		AIR ENTERING EVAPORATOR – CFM								
		2550/0.04			3400/0.05			4250/0.07		
		Air Entering Evaporator – Ewb (F)								
		72	67	62	72	67	62	72	67	62
75	TC	119.20	107.44	96.41	126.95	114.98	103.92	131.87	119.81	109.54
	SHC	50.63	63.94	77.40	59.17	76.72	94.21	66.80	88.44	108.22
	kW	5.67	5.57	5.47	5.54	5.63	5.74	5.79	5.68	5.59
85	TC	110.40	99.22	88.76	117.63	106.26	95.77	122.21	110.77	101.07
	SHC	42.39	56.16	70.07	50.42	68.45	86.38	57.71	79.86	99.95
	kW	6.33	6.23	6.14	6.20	6.30	6.40	6.45	6.34	6.25
95	TC	101.37	90.79	80.86	108.07	97.31	87.39	112.29	101.47	92.38
	SHC	33.97	48.22	62.56	41.46	60.01	78.39	48.40	71.09	91.47
	kW	7.08	6.99	6.90	6.96	7.05	7.16	7.20	7.09	7.01
105	TC	92.04	82.06	72.71	98.19	88.05	78.72	102.07	91.86	83.40
	SHC	25.31	40.06	54.88	32.24	51.33	70.17	38.85	62.06	82.67
	kW	7.94	7.85	7.77	7.83	7.91	8.01	8.06	7.95	7.87
115	TC	82.37	73.01	64.24	87.95	78.45	69.73	91.46	81.90	74.09
	SHC	16.38	31.65	46.95	22.71	42.37	61.69	28.94	52.74	73.52
	kW	8.92	8.84	8.77	8.82	8.89	8.98	9.02	8.93	8.86

8.5 TON COOLING CAPACITIES, UNIT WITH HOT GAS REHEAT SYSTEM IN HOT GAS REHEAT MODE										
TEMP (F) AIR ENT CONDENSER (Edb)		AIR ENTERING EVAPORATOR – Ewb (F)								
		75 Dry Bulb 62.5 Wet Bulb (50% Relative)			75 Dry Bulb 64 Wet Bulb (56% Relative)			75 Dry Bulb 65.3 Wet Bulb (60% Relative)		
		Air Entering Evaporator – Cfm								
		2550	3400	4250	2550	3400	4250	2550	3400	4250
80	TC	37.61	33.13	26.77	44.74	41.60	36.46	50.96	48.99	44.93
	SHC	-0.52	-0.63	-0.73	-0.46	-0.57	-0.67	-0.42	-0.53	-0.62
	kW	5.88	5.68	5.44	6.13	5.97	5.76	6.35	6.24	6.06
75	TC	38.71	34.24	27.86	45.84	42.73	37.59	52.05	50.11	46.06
	SHC	0.45	0.34	0.25	0.50	0.40	0.31	0.54	0.44	0.36
	kW	5.68	5.47	5.22	5.94	5.78	5.56	6.18	6.07	5.88
70	TC	39.70	35.25	28.83	46.80	43.70	38.59	52.97	51.04	47.02
	SHC	1.41	1.32	1.23	1.47	1.37	1.29	1.50	1.41	1.34
	kW	5.65	5.42	5.24	5.97	5.79	5.53	6.26	6.13	5.91
60	TC	41.77	37.33	30.76	48.86	45.80	40.71	55.00	53.10	49.12
	SHC	3.34	3.26	3.18	3.40	3.32	3.25	3.43	3.36	3.29
	kW	5.42	5.15	5.17	5.80	5.59	5.30	6.16	6.01	5.75
50	TC	43.83	39.27	32.61	50.92	47.89	42.70	57.04	55.16	51.22
	SHC	5.27	5.21	5.14	5.32	5.27	5.21	5.36	5.31	5.25
	kW	5.18	5.15	5.17	5.62	5.39	5.05	6.04	5.87	5.59
40	TC	45.75	41.13	34.50	53.08	50.00	44.64	59.24	57.40	53.44
	SHC	7.20	7.15	6.95	7.26	7.21	7.16	7.29	7.25	7.21
	kW	4.79	4.98	4.80	5.25	5.01	5.23	5.68	5.51	5.21

**LEGEND**

- Edb - Entering Dry-Bulb
- Ewb - Entering Wet-Bulb
- kW - Compressor Motor Power Input
- ldb - Leaving Dry-Bulb
- lwb - Leaving Wet-Bulb
- SHC - Sensible Heat Capacity (1000 Btuh) Gross
- TC - Total Capacity (1000 Btuh) Gross

**NOTES:**

- 14. Direct interpolation is permissible. Do not extrapolate.
- 15. The following formulas may be used:

$$t_{ldb} = t_{edb} - \frac{\text{sensible capacity (Btuh)}}{1.10 \times \text{cfm}}$$

$t_{lwb}$  = Wet-bulb temperature corresponding to enthalpy of air leaving evaporator coil ( $h_{lwb}$ )

$$h_{lwb} = h_{ewb} - \frac{\text{total capacity (Btuh)}}{4.5 \times \text{cfm}}$$

Where:  $h_{ewb}$  = Enthalpy of air entering evaporator coil

**Table 27 – COOLING CAPACITIES – 1 STAGE COOLING – 10 TONS**

RGS121			AMBIENT TEMPERATURE											
			85			95			105			115		
			EAT (db)			EAT (db)			EAT (db)			EAT (db)		
Cfm	EAT (wb)	58	75	80	85	75	80	85	75	80	85	75	80	85
			3000	TC	106.3	106.3	120.5	101.7	101.7	115.2	96.6	96.6	109.4	91.0
	SHC	92.2	106.3	120.5	88.2	101.7	115.2	83.8	96.6	109.4	78.9	91.0	103.1	
	62	TC	112.5	112.5	115.2	106.5	106.5	112.3	99.9	99.9	109.0	92.7	92.7	105.2
		SHC	83.8	99.5	115.2	81.0	96.6	112.3	77.8	93.4	109.0	74.2	89.7	105.2
	67	TC	123.5	123.5	123.5	117.8	117.8	117.8	111.3	111.3	111.3	104.0	104.0	104.0
		SHC	69.2	85.0	100.7	66.8	82.5	98.3	64.1	79.8	95.5	61.0	76.8	92.5
	72	TC	134.3	134.3	134.3	128.5	128.5	128.5	122.0	122.0	122.0	114.7	114.7	114.7
		SHC	53.8	69.6	85.5	51.6	67.4	83.2	49.1	64.9	80.7	46.3	62.1	77.9
	76	TC	-	142.4	142.4	-	136.3	136.3	-	129.5	129.5	-	121.8	121.8
		SHC	-	56.8	73.3	-	54.7	71.2	-	52.3	68.8	-	49.7	66.2
	58	TC	112.9	112.9	127.8	108.0	108.0	122.3	102.7	102.7	116.3	96.8	96.8	109.7
		SHC	97.9	112.9	127.8	93.6	108.0	122.3	89.0	102.7	116.3	83.9	96.8	109.7
	62	TC	116.3	116.3	126.2	110.5	110.5	123.3	103.8	103.8	119.5	97.1	97.1	114.3
		SHC	90.2	108.2	126.2	87.4	105.3	123.3	84.0	101.8	119.5	79.8	97.1	114.3
	67	TC	126.9	126.9	126.9	120.9	120.9	120.9	114.3	114.3	114.3	106.8	106.8	106.8
		SHC	73.2	91.3	109.4	70.8	88.9	107.1	68.1	86.2	104.4	65.0	83.2	101.3
	72	TC	137.5	137.5	137.5	131.4	131.4	131.4	124.7	124.7	124.7	117.2	117.2	117.2
		SHC	55.3	73.4	91.5	53.1	71.1	89.2	50.6	68.7	86.7	47.8	65.9	83.9
	76	TC	-	145.1	145.1	-	138.8	138.8	-	131.7	131.7	-	123.6	123.6
		SHC	-	59.0	78.2	-	56.7	75.8	-	54.3	73.1	-	51.5	70.0
	58	TC	117.8	117.8	133.5	113.0	113.0	128.0	107.5	107.5	121.8	101.5	101.5	115.0
		SHC	102.2	117.8	133.5	98.0	113.0	128.0	93.3	107.5	121.8	88.0	101.5	115.0
	62	TC	119.1	119.1	136.0	113.5	113.5	132.5	107.7	107.7	126.7	101.6	101.6	119.6
		SHC	95.8	115.9	136.0	92.8	112.6	132.5	88.6	107.7	126.7	83.6	101.6	119.6
	67	TC	129.4	129.4	129.4	123.3	123.3	123.3	116.5	116.5	116.5	108.9	108.9	109.8
		SHC	76.9	97.3	117.7	74.5	95.0	115.4	71.8	92.3	112.8	68.8	89.3	109.8
	72	TC	139.7	139.7	139.7	133.5	133.5	133.5	126.6	126.6	126.6	118.8	118.8	118.8
		SHC	56.7	76.8	97.0	54.4	74.6	94.7	51.9	72.1	92.3	49.1	69.3	89.5
	76	TC	-	147.0	147.0	-	140.5	140.5	-	133.2	133.2	-	124.9	124.9
		SHC	-	60.6	81.7	-	58.4	79.3	-	55.8	76.5	-	53.0	73.5
	58	TC	121.7	121.7	137.9	116.8	116.8	132.3	111.2	111.2	126.0	105.0	105.0	118.9
		SHC	105.6	121.7	137.9	101.3	116.8	132.3	96.4	111.2	126.0	91.0	105.0	118.9
	62	TC	121.8	121.8	143.4	116.9	116.9	137.6	111.3	111.3	131.0	105.1	105.1	123.7
		SHC	100.2	121.8	143.4	96.1	116.9	137.6	91.6	111.3	131.0	86.5	105.1	123.7
	67	TC	131.3	131.3	131.3	125.1	125.1	125.1	118.2	118.2	120.8	110.5	110.5	117.7
		SHC	80.3	102.9	125.5	78.0	100.7	123.3	75.3	98.0	120.8	72.3	95.0	117.7
	72	TC	141.5	141.5	141.5	135.1	135.1	135.1	128.0	128.0	128.0	120.1	120.1	120.1
		SHC	57.9	80.0	102.1	55.6	77.7	99.9	53.1	75.2	97.4	50.3	72.4	94.6
	76	TC	-	148.3	148.3	-	141.8	141.8	-	134.3	134.3	-	125.8	125.8
		SHC	-	62.1	84.9	-	59.8	82.5	-	57.3	79.7	-	54.4	76.6
	58	TC	125.0	125.0	141.6	120.0	120.0	135.9	114.3	114.3	129.5	107.9	107.9	122.3
		SHC	108.4	125.0	141.6	104.0	120.0	135.9	99.1	114.3	129.5	93.6	107.9	122.3
	62	TC	125.1	125.1	147.2	120.1	120.1	141.4	114.4	114.4	134.7	108.0	108.0	127.2
		SHC	102.9	125.1	147.2	98.8	120.1	141.4	94.1	114.4	134.7	88.9	108.0	127.2
	67	TC	132.8	132.8	133.0	126.5	126.5	130.8	119.6	119.6	128.2	111.8	111.8	125.1
		SHC	83.6	108.3	133.0	81.2	106.0	130.8	78.6	103.4	128.2	75.6	100.3	125.1
	72	TC	142.8	142.8	142.8	136.3	136.3	136.3	129.1	129.1	129.1	121.1	121.1	121.1
		SHC	59.0	82.9	106.9	56.7	80.7	104.7	54.1	78.2	102.2	51.3	75.4	99.4
	76	TC	-	149.4	149.4	-	142.8	142.8	-	135.1	135.1	-	126.5	126.5
		SHC	-	63.4	87.9	-	61.2	85.5	-	58.6	82.7	-	55.6	79.4

**LEGEND:**

- Do not operate in this region
- Cfm - Cubic feet per minute (supply air)
- EAT(db) - Entering air temperature (dry bulb)
- EAT(wb) - Entering air temperature (wet bulb)
- SHC - Sensible heat capacity
- TC - Total cooling capacity

**Table 28 – COOLING CAPACITIES – 2 STAGE COOLING – 10 TONS**

RGS120			AMBIENT TEMPERATURE												
			85			95			105			115			
			EAT (db)			EAT (db)			EAT (db)			EAT (db)			
			75	80	85	75	80	85	75	80	85	75	80	85	
3000 Cfm	EAT (wb)	58	TC	107.6	107.6	121.9	102.5	102.5	116.2	96.8	96.8	109.7	90.5	90.5	102.6
			SHC	93.2	107.6	121.9	88.8	102.5	116.2	83.9	96.8	109.7	78.4	90.5	102.6
		62	TC	113.6	113.6	116.5	107.1	107.1	113.4	99.7	99.7	109.8	91.8	91.8	104.9
			SHC	84.6	100.6	116.5	81.5	97.4	113.4	78.0	93.9	109.8	73.7	89.3	104.9
		67	TC	124.4	124.4	124.4	118.4	118.4	118.4	111.5	111.5	111.5	103.3	103.3	103.3
	SHC		69.7	85.7	101.7	67.1	83.2	99.2	64.3	80.3	96.3	60.8	76.8	92.8	
	72	TC	135.8	135.8	135.8	129.7	129.7	129.7	122.8	122.8	122.8	115	115	115	
		SHC	54.3	70.4	86.6	52.0	68.1	84.2	49.3	65.4	81.6	46.4	62.5	78.6	
	76	TC	-	145.3	145.3	-	139	139	-	131.9	131.9	-	124.1	124.1	
		SHC	-	57.8	74.3	-	55.6	72.1	-	53.1	69.6	-	50.4	66.9	
3500 Cfm	EAT (wb)	58	TC	114.2	114.2	129.4	108.9	108.9	123.4	102.9	102.9	116.6	96.3	96.3	109.1
			SHC	98.9	114.2	129.4	94.3	108.9	123.4	89.1	102.9	116.6	83.4	96.3	109.1
		62	TC	117.2	117.2	127.9	111.0	111.0	124.7	104.0	104.0	119.5	96.5	96.5	113.7
			SHC	91.1	109.5	127.9	88.1	106.4	124.7	83.9	101.7	119.5	79.3	96.5	113.7
		67	TC	127.8	127.8	127.8	121.7	121.7	121.7	114.5	114.5	114.5	106.6	106.6	106.6
	SHC		73.8	92.3	110.8	71.3	89.8	108.3	68.4	87.0	105.5	65.2	83.8	102.3	
	72	TC	139.4	139.4	139.4	133.0	133.0	133	125.8	125.8	125.8	117.9	117.9	117.9	
		SHC	56.0	74.6	93.1	53.7	72.2	90.8	51.0	69.6	88.2	48.1	66.7	85.4	
	76	TC	-	148.8	148.8	-	142.2	142.2	-	134.9	134.9	-	126.8	126.8	
		SHC	-	60.2	79.5	-	58.0	77.1	-	55.4	74.5	-	52.7	71.6	
4000 Cfm	EAT (wb)	58	TC	119.0	119.0	134.9	114.0	114.0	129.2	108.0	108.0	122.4	101.1	101.1	114.6
			SHC	103.1	119.0	134.9	98.7	114.0	129.2	93.6	108.0	122.4	87.6	101.1	114.6
		62	TC	120.3	120.3	137.1	114.7	114.7	132.8	108.2	108.2	127.5	101.3	101.3	119.3
			SHC	96.5	116.8	137.1	93.0	112.9	132.8	88.9	108.2	127.5	83.2	101.3	119.3
		67	TC	130.5	130.5	130.5	124.1	124.1	124.1	116.8	116.8	116.8	108.7	108.7	111.1
	SHC		77.7	98.6	119.5	75.2	96.2	117.2	72.3	93.3	114.4	69.1	90.1	111.1	
	72	TC	142.1	142.1	142.1	135.5	135.5	135.5	128.2	128.2	128.2	120.0	120.0	120.0	
		SHC	57.6	78.4	99.3	55.2	76.1	97.1	52.5	73.6	94.6	49.7	70.7	91.8	
	76	TC	-	151.4	151.4	-	144.7	144.7	-	137.1	137.1	-	-	-	
		SHC	-	62.3	83.8	-	60.0	81.4	-	57.5	78.8	-	-	-	
4500 Cfm	EAT (wb)	58	TC	123.0	123.0	139.5	117.8	117.8	133.6	111.9	111.9	126.9	105.3	105.3	119.3
			SHC	106.6	123.0	139.5	102.1	117.8	133.6	97.0	111.9	126.9	91.2	105.3	119.3
		62	TC	123.4	123.4	144.4	117.9	117.9	139.0	112.0	112.0	132.0	105.4	105.4	124.2
			SHC	100.9	122.7	144.4	96.9	117.9	139	92.1	112.0	132	86.6	105.4	124.2
		67	TC	132.6	132.6	132.6	126.0	126	126.0	118.7	118.7	122.9	110.4	110.4	119.6
	SHC		81.4	104.6	127.9	78.9	102.3	125.7	76.1	99.5	122.9	72.9	96.2	119.6	
	72	TC	144.2	144.2	144.2	137.4	137.4	137.4	129.9	129.9	129.9	121.6	121.6	121.6	
		SHC	59.0	82.1	105.2	56.6	79.8	103.1	54.0	77.3	100.7	51.1	74.5	98	
	76	TC	-	153.4	153.4	-	146.6	146.6	-	138.9	138.9	-	-	-	
		SHC	-	64.1	87.8	-	61.9	85.6	-	59.4	83	-	-	-	
5000 Cfm	EAT (wb)	58	TC	126.5	126.5	143.3	121.2	121.2	137.4	115.1	115.1	130.5	108.4	108.4	122.8
			SHC	109.6	126.5	143.3	105.0	121.2	137.4	99.8	115.1	130.5	93.9	108.4	122.8
		62	TC	126.5	126.5	149.1	121.3	121.3	142.9	115.2	115.2	135.8	108.5	108.5	127.8
			SHC	104.0	126.5	149.1	99.7	121.3	142.9	94.7	115.2	135.8	89.1	108.5	127.8
		67	TC	134.2	134.2	135.9	127.5	127.5	133.8	120.1	120.1	131.0	111.9	111.9	127.6
	SHC		84.9	110.4	135.9	82.4	108.1	133.8	79.6	105.3	131	76.4	102.0	127.6	
	72	TC	145.8	145.8	145.8	139.0	139.0	139.0	131.3	131.3	131.3	122.9	122.9	122.9	
		SHC	60.3	85.6	110.8	57.9	83.4	108.9	55.3	81.0	106.6	52.5	78.2	104	
	76	TC	-	155.1	155.1	-	148.2	148.2	-	-	-	-	-	-	
		SHC	-	65.9	91.5	-	63.7	89.5	-	-	-	-	-	-	

**LEGEND:**

- Do not operate in this region
- Cfm – Cubic feet per minute (supply air)
- EAT(db) – Entering air temperature (dry bulb)
- EAT(wb) – Entering air temperature (wet bulb)
- SHC – Sensible heat capacity
- TC – Total capacity

10 TONS COOLING CAPACITIES, UNIT WITH HOT GAS REHEAT SYSTEM IN SUBCOOLING MODE										
TEMP (F) AIR ENT CONDENSER (Edb)		AIR ENTERING EVAPORATOR – CFM								
		3000/0.04			4000/0.06			5000/0.07		
		Air Entering Evaporator – Ewb (F)								
		72	67	62	72	67	62	72	67	62
75	TC	142.85	129.44	116.93	152.09	138.44	125.76	157.99	144.23	132.06
	SHC	58.38	74.88	91.58	67.96	89.45	111.02	76.63	102.94	127.93
	kW	7.19	6.97	6.79	6.92	7.12	7.35	7.45	7.22	7.02
85	TC	132.33	119.68	107.86	140.92	128.03	116.10	146.41	133.41	121.98
	SHC	48.44	65.56	82.83	57.37	79.50	101.68	65.65	92.58	118.12
	kW	7.98	7.77	7.58	7.72	7.92	8.14	8.25	8.01	7.82
95	TC	121.41	109.52	98.43	129.35	117.22	106.04	134.43	122.20	111.50
	SHC	38.19	55.92	73.78	46.47	69.22	92.01	54.34	81.92	107.96
	kW	8.87	8.66	8.48	8.61	8.80	9.03	9.14	8.90	8.71
105	TC	110.04	98.92	88.56	117.27	105.94	95.53	121.88	110.46	100.54
	SHC	27.59	45.94	64.39	35.16	58.57	81.98	42.56	70.82	97.40
	kW	9.86	9.66	9.48	9.61	9.79	10.02	10.12	9.89	9.70
115	TC	98.09	87.74	78.13	104.62	94.08	84.45	108.76	98.13	89.01
	SHC	16.52	35.47	54.53	23.37	47.44	71.46	30.32	59.25	86.31
	kW	10.95	10.76	10.60	10.72	10.89	11.10	11.19	10.98	10.81

10 TONS COOLING CAPACITIES, UNIT WITH HOT GAS REHEAT SYSTEM IN HOT GAS REHEAT MODE										
TEMP (F) AIR ENT CONDENSER (Edb)		AIR ENTERING EVAPORATOR – Ewb (F)								
		75 Dry Bulb 62.5 Wet Bulb (50% Relative)			75 Dry Bulb 64 Wet Bulb (56% Relative)			75 Dry Bulb 65.3 Wet Bulb (60% Relative)		
		Air Entering Evaporator – Cfm								
		3000	4000	5000	3000	4000	5000	3000	4000	5000
80	TC	44.78	39.41	31.89	53.22	49.44	43.38	60.56	58.12	53.32
	SHC	-0.44	-0.57	-0.69	-0.37	-0.51	-0.61	-0.33	-0.46	-0.56
	kW	6.96	6.77	6.52	7.26	7.13	6.91	7.54	7.45	7.27
75	TC	45.84	40.46	32.86	54.28	50.51	44.45	61.61	59.19	54.40
	SHC	0.53	0.40	0.29	0.60	0.47	0.37	0.64	0.52	0.42
	kW	6.77	6.56	6.29	7.11	6.95	6.72	7.41	7.31	7.12
70	TC	46.91	41.48	33.50	55.36	51.59	45.50	62.69	60.28	55.49
	SHC	1.51	1.38	1.27	1.57	1.45	1.35	1.61	1.50	1.40
	kW	6.54	6.32	6.02	6.90	6.74	6.49	7.23	7.13	6.92
60	TC	48.88	43.42	35.76	57.29	53.56	47.48	64.56	62.16	57.42
	SHC	3.44	3.34	3.24	3.51	3.40	3.31	3.55	3.45	3.37
	kW	6.45	6.16	6.70	6.93	6.72	6.39	7.38	7.24	6.96
50	TC	50.83	45.28	37.67	59.22	55.52	49.43	66.05	64.03	59.34
	SHC	5.38	5.29	5.20	5.45	5.36	5.28	5.48	5.40	5.33
	kW	6.46	6.01	6.34	6.98	6.71	6.29	8.15	7.38	7.02
40	TC	52.82	47.29	39.50	61.14	57.48	51.39	68.23	65.88	61.25
	SHC	7.32	7.24	7.20	7.38	7.31	7.24	7.43	7.36	7.29
	kW	6.29	6.09	6.12	7.05	6.72	6.29	7.78	7.55	7.10

**LEGEND**

- Edb - Entering Dry-Bulb
- Ewb - Entering Wet-Bulb
- kW - Compressor Motor Power Input
- ldb - Leaving Dry-Bulb
- lwb - Leaving Wet-Bulb
- SHC - Sensible Heat Capacity (1000 Btuh) Gross
- TC - Total Capacity (1000 Btuh) Gross

**NOTES:**

- 16. Direct interpolation is permissible. Do not extrapolate.
- 17. The following formulas may be used:

$$t_{ldb} = t_{edb} - \frac{\text{sensible capacity (Btuh)}}{1.10 \times \text{cfm}}$$

$t_{lwb}$  = Wet-bulb temperature corresponding to enthalpy of air leaving evaporator coil ( $h_{lwb}$ )

$$h_{lwb} = h_{ewb} - \frac{\text{total capacity (Btuh)}}{4.5 \times \text{cfm}}$$

Where:  $h_{ewb}$  = Enthalpy of air entering evaporator coil

**Table 30 – COOLING CAPACITIES – 2 STAGE COOLING – 12.5 TONS**

RGS150				AMBIENT TEMPERATURE											
				85			95			105			115		
				EAT (db)			EAT (db)			EAT (db)			EAT (db)		
		75	80	85	75	80	85	75	80	85	75	80	85		
3600 Cfm	EAT (wb)	58	TC	127.6	127.6	142.9	121.7	121.7	137.6	115.0	115.0	130	108.3	108.3	122.6
			SHC	110.3	126.6	142.9	105.8	121.7	137.6	99.9	115.0	130	94.1	108.3	122.6
		62	TC	136.1	136.1	136.1	131.1	131.1	131.1	123.8	123.8	124.5	114.9	114.9	120.3
			SHC	96.6	112.8	129.0	94.7	111.2	127.7	91.4	108.0	124.5	87.3	103.8	120.3
		67	TC	146.2	146.2	146.2	142.0	142.0	142.0	136.2	136.2	136.2	128.8	128.8	128.8
		SHC	78.5	94.4	110.3	76.9	93.1	109.2	74.7	91.0	107.3	71.7	88.1	104.6	
		72	TC	155.9	155.9	155.9	152.4	152.4	152.4	147.2	147.2	147.2	140.1	140.1	140.1
		SHC	60.1	76.6	93.2	58.7	75.2	91.7	56.8	73.3	89.7	54.2	70.6	87.0	
		76	TC	-	163.0	163	-	160.0	160	-	155.1	155.1	-	148.2	148.2
		SHC	-	62.0	81.8	-	61.1	80.9	-	59.5	79.3	-	57.0	76.3	
4200 Cfm	EAT (wb)	58	TC	132.2	132.2	149.5	128.2	128.2	144.9	121.9	121.9	137.8	115.0	115.0	130.1
			SHC	115.0	132.2	149.5	111.5	128.2	144.9	106.0	121.9	137.8	99.9	115.0	130.1
		62	TC	139.6	139.6	139.6	134.7	134.7	138	128.0	128.0	135.6	119.1	119.1	131.2
			SHC	102.5	120.8	139	100.8	119.4	138	98.1	116.8	135.6	93.9	112.6	131.2
		67	TC	149.5	149.5	149.5	145.4	145.4	145.4	139.6	139.6	139.6	132.1	132.1	132.1
		SHC	81.8	99.6	117.4	80.6	98.7	116.8	78.5	96.9	115.2	75.7	94.3	112.8	
		72	TC	159.0	159.0	159.0	155.5	155.5	155.5	150.3	150.3	150.3	143.1	143.1	143.1
		SHC	61.4	79.6	97.8	60.2	78.5	96.8	58.3	76.7	95	55.8	74.2	92.5	
		76	TC	-	165.7	165.7	-	162.8	162.8	-	157.8	157.8	-	150.8	150.8
		SHC	-	64.6	87.7	-	63.5	86.3	-	61.5	83.3	-	58.9	79.9	
4800 Cfm	EAT (wb)	58	TC	136.7	136.7	154.5	133.0	133.0	150.3	127.7	127.7	144.3	120.6	120.6	136.4
			SHC	118.9	136.7	154.5	115.7	133.0	150.3	111.0	127.7	144.3	104.9	120.6	136.4
		62	TC	142.2	142.2	147.8	137.4	137.4	147.1	131.0	131.0	144.7	122.8	122.8	140.3
			SHC	107.7	127.8	147.8	106.2	126.7	147.1	103.6	124.2	144.7	99.3	119.8	140.3
		67	TC	152.1	152.1	152.1	148.0	148	148	142.2	142.2	142.2	134.6	134.6	134.6
		SHC	84.8	104.3	123.7	83.8	103.8	123.7	82.0	102.3	122.6	79.4	99.9	120.4	
		72	TC	161.3	161.3	161.3	157.8	157.8	157.8	152.5	152.5	152.5	145.4	145.4	145.4
		SHC	62.6	82.2	101.9	61.4	81.4	101.3	59.7	79.7	99.8	57.2	77.3	97.5	
		76	TC	-	167.7	167.7	-	164.9	164.9	-	159.9	159.9	-	152.8	152.8
		SHC	-	66.4	91.4	-	65	89.2	-	63.1	86.4	-	60.5	83.1	
5400 Cfm	EAT (wb)	58	TC	140.5	140.5	158.8	136.9	136.9	154.7	131.8	131.8	149	125.2	125.2	141.6
			SHC	122.2	140.5	158.8	119	136.9	154.7	114.7	131.8	149	108.9	125.2	141.6
		62	TC	144.3	144.3	155.7	139.6	139.6	155	133.5	133.5	152.4	125.8	125.8	147.8
			SHC	112.2	133.9	155.7	110.9	132.9	155	108.1	130.2	152.4	103.9	125.8	147.8
		67	TC	154.2	154.2	154.2	150.0	150.0	150.0	144.2	144.2	144.2	136.7	136.7	136.7
		SHC	87.6	108.6	129.6	86.8	108.5	130.1	85.2	107.3	129.4	82.8	105.1	127.4	
		72	TC	163.1	163.1	163.1	159.7	159.7	159.7	154.3	154.3	154.3	147.1	147.1	147.1
		SHC	63.6	84.6	105.6	62.5	83.9	105.4	60.8	82.5	104.2	58.4	80.2	102	
		76	TC	-	169.3	169.3	-	166.5	166.5	-	161.5	161.5	-	154.2	154.2
		SHC	-	67.6	93.7	-	66.4	91.7	-	64.5	89.2	-	61.9	86.1	
6000 Cfm	EAT (wb)	58	TC	143.6	143.6	162.3	140.1	140.1	158.3	135.1	135.1	152.7	128.7	128.7	145.5
			SHC	124.9	143.6	162.3	121.8	140.1	158.3	117.5	135.1	152.7	111.9	128.7	145.5
		62	TC	146.1	146.1	162.4	141.7	141.7	161.5	135.6	135.6	159.2	128.8	128.8	151.2
			SHC	116.1	139.3	162.4	114.7	138.1	161.5	112.1	135.6	159.2	106.4	128.8	151.2
		67	TC	155.8	155.8	155.8	151.6	151.6	151.6	145.9	145.9	145.9	138.3	138.3	138.3
		SHC	90.1	112.6	135	89.6	112.8	136	88.3	112.0	135.8	85.9	110.0	134.1	
		72	TC	164.5	164.5	164.5	161.2	161.2	161.2	155.8	155.8	155.8	148.5	148.5	148.5
		SHC	64.5	86.7	108.9	63.5	86.3	109.1	61.9	85.1	108.2	59.6	82.9	106.3	
		76	TC	-	170.6	170.6	-	167.8	167.8	-	162.8	162.8	-	155.5	155.5
		SHC	-	68.7	95.8	-	67.5	94.1	-	65.7	91.8	-	63.3	88.8	

**LEGEND:**

- Do not operate in this region
- Cfm – Cubic feet per minute (supply air)
- EAT(db) – Entering air temperature (dry bulb)
- EAT(wb) – Entering air temperature (wet bulb)
- SHC – Sensible heat capacity
- TC – Total capacity

**TABLE 31 – COOLING CAPACITIES**

**2-STAGE COOLING**

**12.5 TONS**

12.5 TONS COOLING CAPACITIES, UNIT WITH HOT GAS REHEAT SYSTEM IN SUBCOOLING MODE										
TEMP (F) AIR ENT CONDENSER (Edb)		AIR ENTERING EVAPORATOR – CFM								
		3750/0.02			5000/0.06			6250/0.05		
		Air Entering Evaporator – Ewb (F)								
		72	67	62	72	67	62	72	67	62
75	TC	183.66	166.86	151.43	194.90	177.83	162.05	201.97	184.84	170.53
	SHC	79.39	100.52	121.91	91.70	119.42	147.05	102.94	137.00	166.71
	kW	9.82	9.63	9.46	9.58	9.76	9.96	10.04	9.84	9.67
85	TC	172.71	156.78	142.09	183.32	167.13	152.17	189.98	173.73	160.25
	SHC	69.03	90.92	112.95	80.69	109.17	137.51	91.49	126.33	156.65
	kW	10.82	10.63	10.45	10.57	10.76	10.96	11.04	10.84	10.67
95	TC	161.37	146.24	132.38	171.36	156.04	141.86	177.62	162.22	149.50
	SHC	58.44	81.04	103.77	69.42	98.67	127.71	79.83	115.45	146.15
	kW	11.92	11.73	11.56	11.68	11.86	12.05	12.14	11.93	11.77
105	TC	149.57	135.32	122.21	158.89	144.45	131.10	164.74	150.27	138.35
	SHC	47.57	70.92	94.32	57.85	87.91	117.61	67.79	104.26	135.30
	kW	13.12	12.94	12.77	12.89	13.06	13.24	13.32	13.13	12.97
115	TC	137.22	123.88	111.55	145.85	132.33	119.84	151.27	137.71	126.67
	SHC	36.31	60.47	84.57	45.87	76.77	107.19	55.34	92.66	123.98
	kW	14.41	14.25	14.10	14.20	14.35	14.53	14.59	14.42	14.28

12.5 TONS COOLING CAPACITIES, UNIT WITH HOT GAS REHEAT SYSTEM IN HOT GAS REHEAT MODE										
TEMP (F) AIR ENT CONDENSER (Edb)		AIR ENTERING EVAPORATOR – Ewb (F)								
		75 Dry Bulb 62.5 Wet Bulb (50% Relative)			75 Dry Bulb 64 Wet Bulb (56% Relative)			75 Dry Bulb 65.3 Wet Bulb (60% Relative)		
		Air Entering Evaporator – Cfm								
		3750	5000	6250	3750	5000	6250	3750	5000	6250
80	TC	52.42	45.88	36.99	62.64	58.07	51.07	71.56	68.64	63.23
	SHC	-0.39	-0.54	-0.67	-0.31	-0.46	-0.58	-0.26	-0.40	-0.52
	kW	9.65	9.39	9.07	9.97	9.77	9.50	10.25	10.11	9.89
75	TC	53.45	46.63	36.10	63.77	59.11	51.87	72.76	69.80	64.31
	SHC	0.59	0.44	0.30	0.67	0.52	0.40	0.72	0.58	0.47
	kW	9.09	8.83	8.49	9.39	9.20	8.94	9.67	9.53	9.32
70	TC	54.33	46.91	37.58	64.77	60.01	52.30	73.80	70.80	65.24
	SHC	1.56	1.41	1.29	1.64	1.50	1.38	1.70	1.56	1.45
	kW	8.81	8.53	8.62	9.15	8.94	8.65	9.46	9.31	9.08
60	TC	55.47	49.48	40.48	66.62	62.07	54.88	75.68	72.76	67.28
	SHC	3.50	3.38	3.27	3.59	3.47	3.36	3.65	3.52	3.42
	kW	8.36	8.84	8.98	9.88	9.56	9.10	9.83	9.64	9.31
50	TC	58.33	51.72	42.81	68.72	63.93	55.84	77.74	74.77	69.24
	SHC	5.47	5.35	5.24	5.54	5.43	5.32	5.60	5.49	5.39
	kW	8.98	9.25	9.43	9.33	8.97	8.73	9.55	9.33	9.70
40	TC	60.33	53.69	46.89	70.67	65.93	49.83	79.46	76.62	71.24
	SHC	7.42	7.31	7.22	7.49	7.39	7.23	7.55	7.45	7.37
	kW	9.16	9.88	9.06	9.50	9.05	9.47	10.31	10.00	9.48

**LEGEND**

- Edb - Entering Dry-Bulb
- Ewb - Entering Wet-Bulb
- kW - Compressor Motor Power Input
- ldb - Leaving Dry-Bulb
- lwb - Leaving Wet-Bulb
- SHC - Sensible Heat Capacity (1000 Btuh) Gross
- TC - Total Capacity (1000 Btuh) Gross

**NOTES:**

- 18. Direct interpolation is permissible. Do not extrapolate.
- 19. The following formulas may be used:

$$t_{ldb} = t_{edb} - \frac{\text{sensible capacity (Btuh)}}{1.10 \times \text{cfm}}$$

$t_{lwb}$  = Wet-bulb temperature corresponding to enthalpy of air leaving evaporator coil ( $h_{lwb}$ )

$$h_{lwb} = h_{ewb} - \frac{\text{total capacity (Btuh)}}{4.5 \times \text{cfm}}$$

Where:  $h_{ewb}$  = Enthalpy of air entering evaporator coil

**Table 32 – COOLING CAPACITIES – 2 STAGE COOLING – 15 TONS**

RGS180				Ambient Temperature											
				85			95			105			115		
				EA (dB)			EA (dB)			EA (dB)			EA (dB)		
				75	80	85	75	80	85	75	80	85	75	80	85
4500 Cfm	EAT (wb)	58	THC	156.6	156.6	175.2	149.4	149.4	169.1	141.6	141.6	160.2	133.3	133.3	150.9
			SHC	134.7	154.9	175.2	129.8	149.4	169.1	123.0	141.6	160.2	115.7	133.3	150.9
		62	THC	166.7	166.7	166.9	158.0	158.0	162.6	147.6	147.6	157.2	136.8	136.8	150.3
			SHC	122.8	144.9	166.9	118.6	140.6	162.6	113.5	135.3	157.2	107.4	128.8	150.3
		67	THC	184.1	184.1	184.1	175.6	175.6	175.6	165.6	165.6	165.6	154.5	154.5	154.5
	SHC		101.6	123.7	145.7	98.1	120.2	142.3	94.0	116.1	138.2	89.4	111.5	133.6	
	72	THC	200.3	200.3	200.3	192.0	192.0	192.0	182.9	182.9	182.9	172.2	172.2	172.2	
		SHC	78.7	101.1	123.5	75.5	97.9	120.2	72.1	94.4	116.7	68.2	90.5	112.7	
	76	THC	-	211.4	211.4	-	203.1	203.1	-	193.8	193.8	-	183.9	183.9	
		SHC	-	82.2	107.0	-	79.3	103.8	-	76.0	100.2	-	72.6	96.5	
5250 Cfm	EAT (wb)	58	THC	165.2	165.2	186.9	158.2	158.2	179.0	150.0	150.0	169.7	141.3	141.3	160.0
			SHC	143.5	165.2	186.9	137.4	158.2	179.0	130.2	150.0	169.7	122.7	141.3	160.0
		62	THC	172.3	172.3	181.7	163.4	163.4	176.9	153.1	153.1	169.3	143.4	143.4	161.4
			SHC	131.6	156.6	181.7	127.1	152.0	176.9	120.5	144.9	169.3	114.1	137.8	161.4
		67	THC	189.5	189.5	189.5	180.9	180.9	180.9	170.7	170.7	170.7	159.1	159.1	159.1
	SHC		107.2	132.4	157.5	103.8	129.0	154.1	99.9	125.1	150.4	95.3	120.6	145.8	
	72	THC	205.0	205.0	205.0	196.5	196.5	196.5	187.1	187.1	187.1	176.4	176.4	176.4	
		SHC	80.9	106.1	131.3	77.7	102.9	128.1	74.4	99.5	124.7	70.6	95.8	121.0	
	76	THC	-	215.4	215.4	-	206.8	206.8	-	197.1	197.1	-	186.9	186.9	
		SHC	-	85.0	113.0	-	82.0	109.8	-	78.8	106.4	-	75.4	102.8	
6000 Cfm	EAT (wb)	58	THC	172.7	172.7	195.4	165.5	165.5	187.3	157.1	157.1	177.8	148.1	148.1	167.7
			SHC	150.0	172.7	195.4	143.8	165.5	187.3	136.4	157.1	177.8	128.6	148.1	167.7
		62	THC	176.6	176.6	195.7	168.1	168.1	187.6	158.9	158.9	180.2	148.9	148.9	172.1
			SHC	139.6	167.7	195.7	133.2	160.4	187.6	127.1	153.7	180.2	120.7	146.4	172.1
		67	THC	193.6	193.6	193.6	184.8	184.8	184.8	174.7	174.7	174.7	162.7	162.7	162.7
	SHC		112.3	140.3	168.3	108.9	137.0	165.2	105.2	133.5	161.7	100.7	129.0	157.3	
	72	THC	208.4	208.4	208.4	199.6	199.6	199.6	190.2	190.2	190.2	179.5	179.5	179.5	
		SHC	82.7	110.5	138.3	79.6	107.3	135.1	76.2	104.0	131.8	72.6	100.6	128.5	
	76	THC	-	218.2	218.2	-	209.5	209.5	-	199.5	199.5	-	189.0	189.0	
		SHC	-	87.5	118.6	-	84.5	115.2	-	81.1	111.3	-	77.5	107.3	
6750 Cfm	EAT (wb)	58	THC	178.8	178.8	202.4	171.6	171.6	194.2	163.1	163.1	184.6	153.8	153.8	174.1
			SHC	155.3	178.8	202.4	149.0	171.6	194.2	141.6	163.1	184.6	133.5	153.8	174.1
		62	THC	181.0	181.0	203.6	173.0	173.0	197.5	163.8	163.8	190.1	153.9	153.9	181.1
			SHC	144.1	173.9	203.6	139.1	168.3	197.5	133.3	161.7	190.1	126.7	153.9	181.1
		67	THC	196.8	196.8	196.8	187.9	187.9	187.9	177.7	177.7	177.7	165.5	165.5	167.9
	SHC		117.0	147.7	178.4	113.7	144.5	175.4	110.1	141.1	172.2	105.6	136.8	167.9	
	72	THC	211.0	211.0	211.0	202.2	202.2	202.2	192.5	192.5	192.5	181.8	181.8	181.8	
		SHC	84.3	114.5	144.7	81.2	111.5	141.7	77.9	108.1	138.4	74.4	104.9	135.4	
	76	THC	-	220.2	220.2	-	211.5	211.5	-	201.3	201.3	-	190.6	190.6	
		SHC	-	89.5	122.8	-	86.4	119.4	-	83.0	115.4	-	79.4	111.5	
7500 Cfm	EAT (wb)	58	THC	183.9	183.9	208.2	176.6	176.6	199.8	168.2	168.2	190.3	158.6	158.6	179.5
			SHC	159.7	183.9	208.2	153.3	176.6	199.8	146.0	168.2	190.3	137.7	158.6	179.5
		62	THC	185.1	185.1	212.5	177.1	177.1	206.2	168.3	168.3	197.9	158.7	158.7	186.7
			SHC	149.5	181.0	212.5	144.5	175.4	206.2	138.7	168.3	197.9	130.8	158.7	186.7
		67	THC	199.3	199.3	199.3	190.3	190.3	190.3	180.0	180.0	181.7	167.8	167.8	177.8
	SHC		121.3	154.6	187.9	118.1	151.6	185.1	114.4	148.1	181.7	110.1	144.0	177.8	
	72	THC	213.0	213.0	213.0	204.1	204.1	204.1	194.2	194.2	194.2	183.5	183.5	183.5	
		SHC	85.8	118.2	150.5	82.7	115.2	147.7	79.4	111.9	144.4	76.0	108.8	141.6	
	76	THC	-	221.9	221.9	-	213.0	213.0	-	202.7	202.7	-	191.8	191.8	
		SHC	-	91.2	126.5	-	88.2	123.1	-	84.7	119.2	-	81.2	115.3	

**LEGEND:**

- Do not operate in this region
- Cfm – Cubic feet per minute (supply air)
- EAT(db) – Entering air temperature (dry bulb)
- EAT(wb) – Entering air temperature (wet bulb)
- SHC – Sensible heat capacity
- TC – Total capacity



**TABLE 33 – COOLING CAPACITIES**

**2-STAGE COOLING**

**15 TONS**

15 TONS UNIT WITH HOT GAS REHEAT IN SUBCOOLING MODE										
TEMP (F) AIR ENT CONDENSER (Edb)		AIR ENTERING EVAPORATOR – CFM								
		4500/0.02			6000/0.06			7500/0.05		
		Air Entering Evaporator – Ewb (F)								
		72	67	62	72	67	62	72	67	62
75	TC	204.4	186.3	168.2	218.4	199.6	180.9	229.6	210.4	191.2
	SHC	98.9	118.1	137.2	114.8	133.7	152.6	127.6	146.2	164.9
	kW	11.57	11.22	10.77	11.78	11.45	11.00	12.06	11.64	11.35
85	TC	189.2	171.7	154.1	203.0	184.8	166.7	214.1	195.5	176.9
	SHC	79.5	103.4	127.3	96.5	120.2	144.0	110.2	133.7	157.3
	kW	12.59	12.24	11.81	12.81	12.50	12.03	13.05	12.66	12.47
95	TC	174.0	157.0	140.0	187.6	170.1	152.5	198.6	180.6	162.7
	SHC	60.0	88.7	117.5	78.2	106.8	135.3	92.9	121.3	149.7
	kW	13.68	13.35	12.86	13.91	13.57	13.05	14.15	13.75	13.47
105	TC	158.8	142.3	125.8	172.2	155.3	138.3	183.1	165.7	148.4
	SHC	40.5	74.1	107.7	59.9	93.3	126.7	75.5	108.8	142.0
	kW	14.67	14.41	13.88	14.90	14.55	14.10	15.15	14.73	14.53
115	TC	143.6	127.6	111.7	156.8	140.5	124.1	167.6	150.9	134.2
	SHC	21.0	59.4	97.8	41.6	79.9	118.1	58.1	96.3	134.2
	kW	15.77	15.38	14.88	15.88	15.65	15.10	16.12	15.84	15.54

15 TONS UNIT WITH HOT GAS REHEAT MODE										
TEMP (F) AIR ENT CONDENSER (Edb)		AIR ENTERING EVAPORATOR – Ewb (F)								
		75 Dry Bulb 62.5 Wet Bulb (50% Relative)			75 Dry Bulb 64 Wet Bulb (56% Relative)			75 Dry Bulb 65.3 Wet Bulb (60% Relative)		
		Air Entering Evaporator – Cfm								
		4500	6000	7500	4500	6000	7500	4500	6000	7500
80	TC	83.75	84.85	88.95	86.65	91.90	92.90	87.90	91.75	96.30
	SHC	37.50	42.80	55.10	30.90	40.40	44.50	24.80	29.30	34.10
	kW	10.50	11.49	11.60	10.56	10.65	11.70	11.60	11.72	11.77
75	TC	85.00	86.00	90.50	88.05	93.60	94.65	89.20	93.45	97.85
	SHC	40.00	45.00	57.30	33.20	42.30	46.90	26.90	31.50	36.30
	kW	10.16	11.15	11.25	10.21	10.31	11.33	11.26	11.35	11.42
70	TC	86.15	87.35	91.50	89.20	94.30	96.10	90.40	94.10	98.95
	SHC	42.10	47.50	59.80	35.50	45.30	49.50	29.50	33.90	38.70
	kW	9.84	10.83	10.94	10.02	10.13	11.03	10.95	11.05	11.12
60	TC	88.90	90.10	94.25	92.00	97.10	98.20	93.20	96.90	101.75
	SHC	46.80	52.30	64.60	40.20	50.10	54.10	34.10	38.60	43.40
	kW	9.37	10.36	10.44	9.42	9.52	10.55	10.45	10.57	10.64
50	TC	91.70	92.80	97.00	94.80	99.90	101.00	96.10	99.70	104.20
	SHC	51.50	57.10	69.40	44.80	54.80	58.90	38.70	43.20	49.00
	kW	9.12	10.09	10.16	9.17	9.28	10.26	10.17	10.26	10.32
40	TC	94.45	95.60	99.80	97.45	102.55	103.70	98.65	102.35	107.00
	SHC	56.30	61.40	73.70	49.70	59.20	63.30	43.60	48.10	52.90
	kW	9.05	10.02	10.10	9.10	9.21	10.18	10.11	10.20	10.26

**LEGEND**

- Edb** – Entering Dry-Bulb
- Ewb** – Entering Wet-Bulb
- kW** – Compressor Motor Power Input
- ldb** – Leaving Dry-Bulb
- lwb** – Leaving Wet-Bulb
- SHC** – Sensible Heat Capacity (1000 Btuh) Gross
- TC** – Total Capacity (1000 Btuh) Gross

**NOTES:**

- 20. Direct interpolation is permissible. Do not extrapolate.
- 21. The following formulas may be used:

$$t_{ldb} = t_{edb} - \frac{\text{sensible capacity (Btuh)}}{1.10 \times \text{cfm}}$$

$t_{lwb}$  = Wet-bulb temperature corresponding to enthalpy of air leaving evaporator coil ( $h_{lwb}$ )

$$h_{lwb} = h_{ewb} - \frac{\text{total capacity (Btuh)}}{4.5 \times \text{cfm}}$$

Where:  $h_{ewb}$  = Enthalpy of air entering evaporator coil

**Table 34 – STATIC PRESSURE ADDERS (in. wg) (Factory Options and/or Accessories)**

**Hot Gas Reheat**

3–6 TONS									
CFM	1000	1250	1500	1750	2000	2250	2500	2750	3000
3 Tons	0.04	0.052	0.07	–	–	–	–	–	–
4 Tons	–	0.106	0.138	0.172	0.21	–	–	–	–
5 Tons	–	–	0.138	0.172	0.21	0.252	0.30	–	–
6 Tons	–	–	–	0.112	0.125	0.161	0.19	0.22	0.25

7.5–12.5 TONS																
CFM	2250	2500	2750	3000	3250	3500	3750	4000	4250	4500	4750	5000	5250	5500	5750	6000
7.5 Tons	0.12	0.14	0.16	0.19	0.21	0.23	0.26	–	–	–	–	–	–	–	–	–
8.5 Tons	–	0.11	0.12	0.13	0.15	0.17	0.18	0.20	0.22	–	–	–	–	–	–	–
10 Tons	–	–	–	0.13	0.15	0.17	0.18	0.20	0.22	0.24	0.26	0.28	–	–	–	–
12.5 Tons	–	–	–	–	–	0.17	0.18	0.20	0.22	0.24	0.26	0.28	0.31	0.33	0.36	0.39

15 TONS														
CFM	4000	4250	4500	4750	5000	5250	5500	5750	6000	6250	6500	6750	7000	7250
15 Tons	0.06	0.07	0.07	0.08	0.08	0.09	0.10	0.10	0.11	0.12	0.12	0.13	0.14	0.15

**ECONOMIZER, BAROMETRIC RELIEF, AND PE PERFORMANCE**

**Vertical Application**

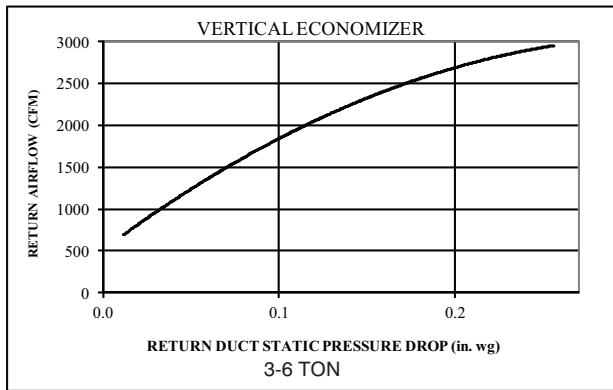

**Return Air Pressure Drop**  
VERTICAL ECONOMIZER

C11238

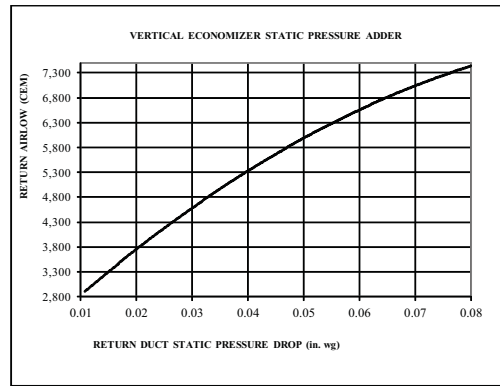

**Return Air Pressure Drop–Vertical 15 Tons**

C11257

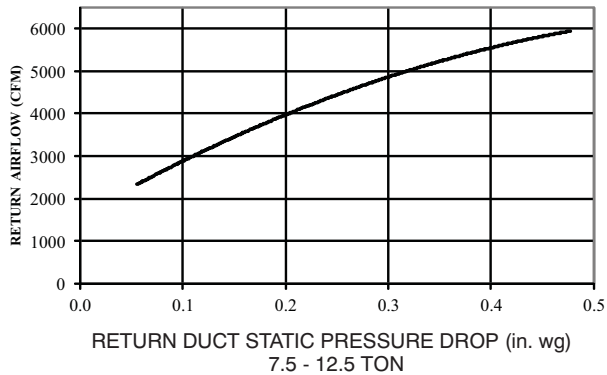

**Return Air Pressure Drop**

C11240

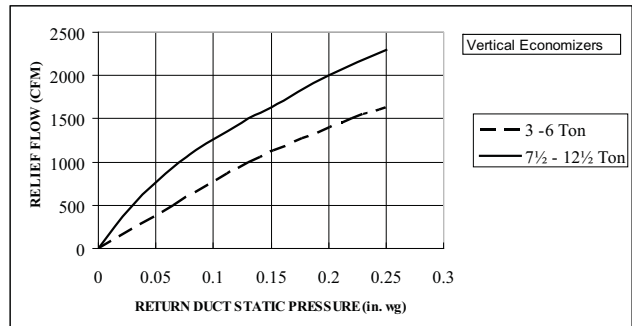

**Barometric Relief Flow Capacity**

C08073

# ECONOMIZER, BAROMETRIC RELIEF AND PE PERFORMANCE (cont.)

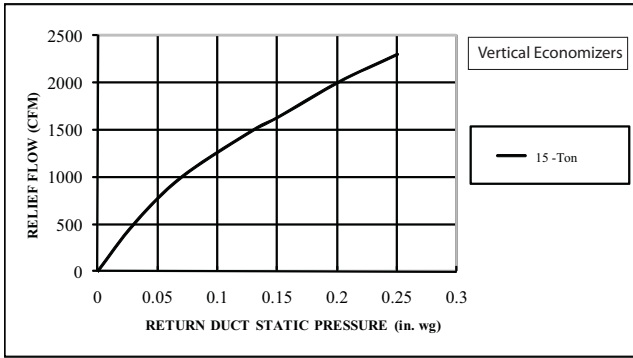

**Barometric Relief Flow-Vertical 15 Ton**

C101122

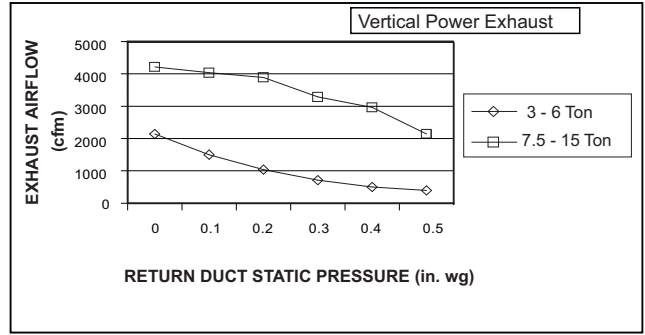

**Vertical Power Exhaust Performance**

C11248

## Horizontal Application

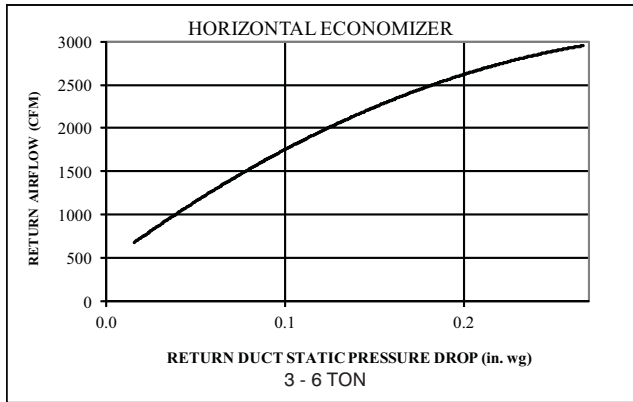

**Return Air Pressure Drop**

C11239

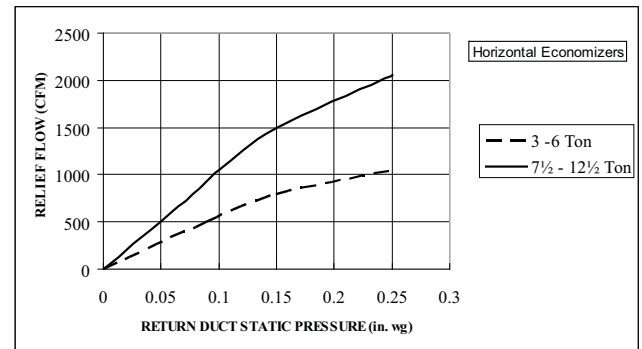

**Barometric Relief Flow Capacity**

C08070

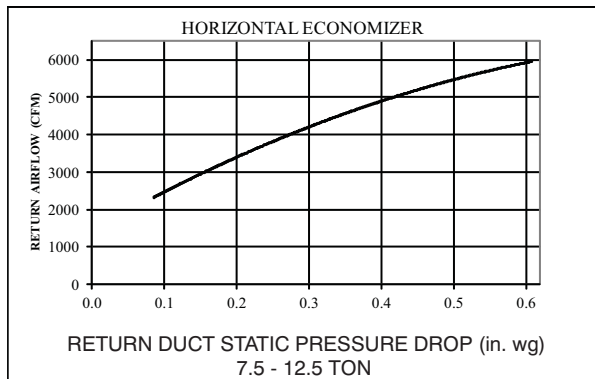

**Return Air Pressure Drop**

C11241

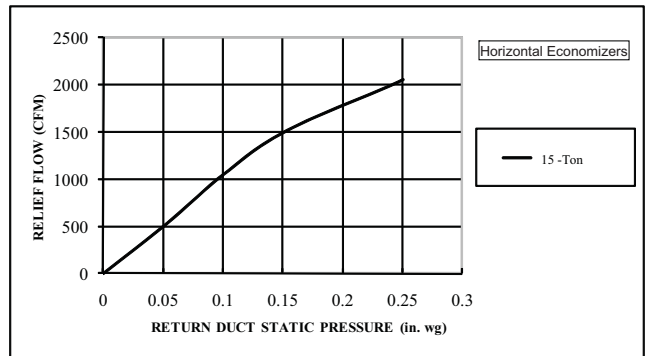

**Barometric Relief Flow-Horizontal 15 Ton**

C101120

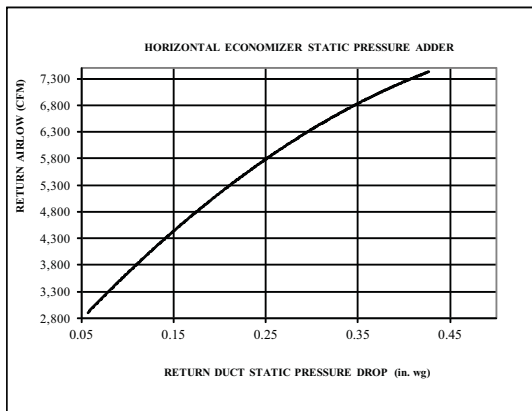

**Return Air Pressure Drop-Horizontal 15 Ton**

C11258

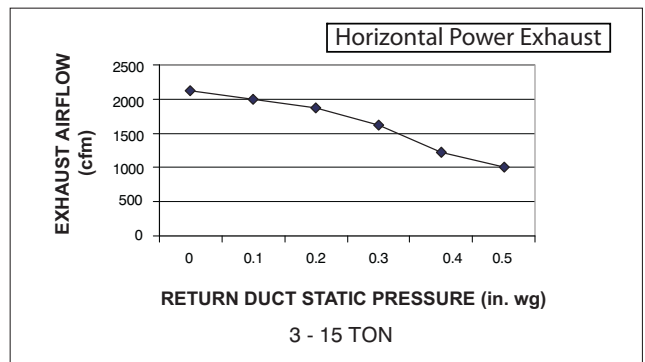

**Horizontal Power Exhaust Performance**

C08012

All above data for both standard and ultra low leak models, where available.

## General fan performance notes:

1. Interpolation is permissible. Do not extrapolate.
2. External static pressure is the static pressure difference between the return duct and the supply duct plus the static pressure caused by any FIOPs or accessories.
3. Tabular data accounts for pressure loss due to clean filters, unit casing, and wet coils. Factory options and accessories may add static pressure losses. Selection software is available to help you select the best motor/drive combination for your application.
4. The Fan Performance tables offer motor/drive recommendations. In cases when two motor/drive combinations would work, recommend the lower horsepower option.
5. For information on the electrical properties of motors, please see the Electrical information section of this book.
6. For more information on the performance limits of motors, see the application data section of this book.
7. The EPACT (Energy Policy Act of 1992) regulates energy requirements for specific types of indoor fan motors. Motors regulated by EPACT include any general purpose, T-frame (three-digit, 143 and larger), single-speed, foot mounted, polyphase, squirrel cage induction motors of NEMA (National Electrical Manufacturers Association) design A and B, manufactured for use in the United States. Ranging from 1 to 200 Hp, these continuous-duty motors operate on 230 and 460 volt, 60 Hz power. If a motor does not fit into these specifications, the motor does not have to be replaced by an EPACT compliant energy efficient motor. Variable speed motors are exempt from EPACT compliance requirements. Therefore, the indoor fan motors for RGS036-180 units are exempt from these requirements.

## FAN PERFORMANCE

**Table 35 – RGS036, 3 PHASE, 3 TON HORIZONTAL SUPPLY**

CFM	AVAILABLE EXTERNAL STATIC PRESSURE (in. wg)									
	0.2		0.4		0.6		0.8		1.0	
	RPM	BHP	RPM	BHP	RPM	BHP	RPM	BHP	RPM	BHP
	Field Supplied Drive <sup>1</sup>		Standard Static Option				Medium Static Option			
900	553	0.14	681	0.22	782	0.32	870	0.42	948	0.53
975	575	0.16	700	0.25	801	0.35	888	0.46	965	0.57
1050	597	0.18	720	0.28	820	0.38	906	0.49	983	0.61
1125	620	0.21	741	0.31	839	0.42	925	0.54	1001	0.66
1200	643	0.23	762	0.34	859	0.46	944	0.58	1020	0.71
1275	667	0.27	783	0.38	879	0.50	963	0.63	1038	0.76
1350	691	0.30	805	0.42	900	0.55	983	0.68	1057	0.82
1425	715	0.34	827	0.47	920	0.60	1002	0.74	1076	0.88
1500	740	0.38	849	0.52	941	0.66	1023	0.80	1096	0.95

CFM	AVAILABLE EXTERNAL STATIC PRESSURE (in. wg)									
	1.2		1.4		1.6		1.8		2.0	
	RPM	BHP	RPM	BHP	RPM	BHP	RPM	BHP	RPM	BHP
	Medium Static Option					High Static Option				
900	1019	0.64	1084	0.76	1146	0.89	1203	1.02	1258	1.16
975	1036	0.69	1101	0.81	1162	0.94	1219	1.08	1274	1.22
1050	1053	0.74	1118	0.86	1179	1.00	1236	1.14	1290	1.28
1125	1071	0.79	1135	0.92	1196	1.06	1253	1.20	1307	1.35
1200	1089	0.84	1153	0.98	1213	1.12	1270	1.27	1324	1.42
1275	1107	0.90	1171	1.04	1231	1.19	1287	1.34	1341	1.50
1350	1126	0.96	1189	1.11	1249	1.26	1305	1.42	1358	1.58
1425	1144	1.03	1208	1.18	1267	1.34	1323	1.50	1376	1.66
1500	1163	1.10	1226	1.25	1285	1.41	1341	1.58	1394	1.75

**NOTE:** For more information, see General Fan Performance Notes on page 60.

1. Recommend using field-supplied blower pulley (part number 1178448) and belt (part number 1177401)

**Table 36 – RGS036, 3 PHASE, 3 TON VERTICAL SUPPLY**

CFM	AVAILABLE EXTERNAL STATIC PRESSURE (in. wg)									
	0.2		0.4		0.6		0.8		1.0	
	RPM	BHP	RPM	BHP	RPM	BHP	RPM	BHP	RPM	BHP
	Field Supplied Drive <sup>1</sup>		Standard Static Option				Medium Static Option			
900	567	0.15	688	0.22	786	0.30	871	0.37	947	0.44
975	591	0.17	710	0.26	807	0.34	891	0.42	966	0.49
1050	615	0.20	732	0.29	828	0.38	911	0.47	985	0.55
1125	641	0.23	755	0.33	849	0.42	931	0.52	1005	0.61
1200	666	0.26	778	0.37	871	0.47	952	0.57	1025	0.67
1275	693	0.29	802	0.41	893	0.53	974	0.63	1046	0.74
1350	719	0.33	826	0.46	916	0.58	995	0.70	1067	0.81
1425	746	0.38	850	0.51	939	0.64	1017	0.76	1088	0.89
1500	773	0.42	875	0.57	963	0.70	1040	0.84	1110	0.96

CFM	AVAILABLE EXTERNAL STATIC PRESSURE (in. wg)									
	1.2		1.4		1.6		1.8		2.0	
	RPM	BHP	RPM	BHP	RPM	BHP	RPM	BHP	RPM	BHP
	Medium Static Option					High Static Option				
900	1016	0.51	1080	0.57	1139	0.64	1195	0.71	1249	0.77
975	1034	0.57	1098	0.64	1157	0.72	1213	0.79	1266	0.86
1050	1053	0.63	1116	0.71	1176	0.79	1231	0.87	1284	0.95
1125	1073	0.70	1135	0.79	1194	0.87	1250	0.96	1302	1.04
1200	1093	0.77	1155	0.87	1213	0.96	1268	1.05	1321	1.14
1275	1113	0.85	1174	0.95	1232	1.05	1287	1.15	1339	1.25
1350	1133	0.92	1194	1.03	1252	1.14	1307	1.25	1358	1.35
1425	1154	1.01	1215	1.12	1272	1.24	1326	1.35	1378	1.46
1500	1175	1.09	1235	1.22	1292	1.34	1346	1.46	1397	1.58

**NOTE:** For more information, see General Fan Performance Notes on page 60.

**Boldface** indicates field-supplied drive is required.

1. Recommend using field-supplied blower pulley (part number 1178448) and belt (part number 1177401)

**Table 37 – RGS048, 1 PHASE, 4 TON HORIZONTAL SUPPLY**

CFM	AVAILABLE EXTERNAL STATIC PRESSURE (in. wg)									
	0.2		0.4		0.6		0.8		1.0	
	RPM	BHP	RPM	BHP	RPM	BHP	RPM	BHP	RPM	BHP
	Standard Static Option				Medium Static Option					
1200	643	0.23	762	0.34	859	0.46	944	0.58	1020	0.71
1300	675	0.28	790	0.40	886	0.52	969	0.65	1044	0.78
1400	707	0.33	819	0.45	913	0.58	996	0.72	1070	0.86
1500	740	0.38	849	0.52	941	0.66	1023	0.80	1096	0.95
1600	773	0.45	879	0.59	970	0.73	1050	0.88	1123	1.04
1700	807	0.52	910	0.67	999	0.82	1078	0.98	1150	1.14
1800	841	0.59	942	0.75	1029	0.91	1106	1.08	—	—
1900	875	0.68	974	0.85	1059	1.02	1135	1.19	—	—
2000	910	0.77	1006	0.95	1090	1.13	1165	1.31	—	—

CFM	AVAILABLE EXTERNAL STATIC PRESSURE (in. wg)									
	1.2		1.4		1.6		1.8		2.0	
	RPM	BHP	RPM	BHP	RPM	BHP	RPM	BHP	RPM	BHP
	Medium Static Option					Field Supplied Drive <sup>1</sup>				
1200	1089	0.84	1153	0.98	1213	1.12	—	—	—	—
1300	1113	0.92	1177	1.06	—	—	—	—	—	—
1400	1138	1.01	1201	1.15	—	—	—	—	—	—
1500	1163	1.10	—	—	—	—	—	—	—	—
1600	1189	1.20	—	—	—	—	—	—	—	—
1700	—	—	—	—	—	—	—	—	—	—
1800	—	—	—	—	—	—	—	—	—	—
1900	—	—	—	—	—	—	—	—	—	—
2000	—	—	—	—	—	—	—	—	—	—

**NOTE:** For more information, see General Fan Performance Notes on page 60.

**Boldface** indicates field-supplied drive is required.

1. Recommend using field-supplied blower pulley (part number 1175832) and belt (part number 1178128)

# FAN PERFORMANCE (cont.)

**Table 38 – RGS048, 1 PHASE, 4 TON VERTICAL SUPPLY**

CFM	AVAILABLE EXTERNAL STATIC PRESSURE (in. wg)									
	0.2		0.4		0.6		0.8		1.0	
	RPM	BHP	RPM	BHP	RPM	BHP	RPM	BHP	RPM	BHP
	Standard Static Option					Medium Static Option				
1200	666	0.26	778	0.37	871	0.47	952	0.57	1025	0.67
1300	701	0.31	810	0.43	901	0.54	981	0.65	1053	0.76
1400	737	0.36	842	0.49	931	0.62	1010	0.74	1081	0.86
1500	773	0.42	875	0.57	963	0.70	1040	0.84	1110	0.96
1600	810	0.49	909	0.65	994	0.79	1070	0.94	1140	1.08
1700	847	0.57	943	0.73	1027	0.89	1101	1.05	1170	1.20
1800	885	0.66	978	0.83	1060	1.00	1133	1.16	–	–
1900	923	0.75	1014	0.94	1093	1.11	1165	1.29	–	–
2000	962	0.85	1049	1.05	–	–	–	–	–	–

CFM	AVAILABLE EXTERNAL STATIC PRESSURE (in. wg)									
	1.2		1.4		1.6		1.8		2.0	
	RPM	BHP	RPM	BHP	RPM	BHP	RPM	BHP	RPM	BHP
	Medium Static Option					Field Supplied Drive <sup>1</sup>				
1200	1093	0.77	1155	0.87	1213	0.96	1268	1.05	1321	1.14
1300	1119	0.87	1181	0.98	1239	1.08	1294	1.18	–	–
1400	1147	0.98	1208	1.09	–	–	–	–	–	–
1500	1175	1.09	–	–	–	–	–	–	–	–
1600	–	–	–	–	–	–	–	–	–	–
1700	–	–	–	–	–	–	–	–	–	–
1800	–	–	–	–	–	–	–	–	–	–
1900	–	–	–	–	–	–	–	–	–	–
2000	–	–	–	–	–	–	–	–	–	–

**NOTE:** For more information, see General Fan Performance Notes on page 60.

**Boldface** indicates field-supplied drive is required.

1. Recommend using field-supplied blower pulley (part number 1175832) and belt (part number 1178128)

**Table 39 – RGS048, 3 PHASE, 4 TON HORIZONTAL SUPPLY**

CFM	AVAILABLE EXTERNAL STATIC PRESSURE (in. wg)									
	0.2		0.4		0.6		0.8		1.0	
	RPM	BHP	RPM	BHP	RPM	BHP	RPM	BHP	RPM	BHP
	Standard Static Option					Medium Static Option				
1200	643	0.23	762	0.34	859	0.46	944	0.58	1020	0.71
1300	675	0.28	790	0.40	886	0.52	969	0.65	1044	0.78
1400	707	0.33	819	0.45	913	0.58	996	0.72	1070	0.86
1500	740	0.38	849	0.52	941	0.66	1023	0.80	1096	0.95
1600	773	0.45	879	0.59	970	0.73	1050	0.88	1123	1.04
1700	807	0.52	910	0.67	999	0.82	1078	0.98	1150	1.14
1800	841	0.59	942	0.75	1029	0.91	1106	1.08	1177	1.25
1900	875	0.68	974	0.85	1059	1.02	1135	1.19	1205	1.37
2000	910	0.77	1006	0.95	1090	1.13	1165	1.31	1234	1.49

CFM	AVAILABLE EXTERNAL STATIC PRESSURE (in. wg)									
	1.2		1.4		1.6		1.8		2.0	
	RPM	BHP	RPM	BHP	RPM	BHP	RPM	BHP	RPM	BHP
	Medium Static Option					High Static Option				
1200	1089	0.84	1153	0.98	1213	1.12	1270	1.27	1324	1.42
1300	1113	0.92	1177	1.06	1237	1.21	1293	1.36	1347	1.52
1400	1138	1.01	1201	1.15	1261	1.31	1317	1.47	1370	1.63
1500	1163	1.10	1226	1.25	1285	1.41	1341	1.58	1394	1.75
1600	1189	1.20	1252	1.36	1310	1.53	1365	1.70	1418	1.87
1700	1216	1.31	1277	1.48	1335	1.65	1390	1.83	1442	2.01
1800	1242	1.42	1303	1.60	1361	1.78	1415	1.96	1467	2.15
1900	1270	1.55	1330	1.73	1387	1.92	1441	2.11	1493	2.30
2000	1297	1.68	1357	1.87	1414	2.07	1467	2.26	–	–

**NOTE:** For more information, see General Fan Performance Notes on page 60.

**Boldface** indicates field-supplied drive is required.

1. Recommend using field-supplied blower pulley (part no. 1175314), motor pulley (part no. 1170551) and belt (part no. 1178451).

# FAN PERFORMANCE (cont.)

Table 40 – RGS048, 3 PHASE, 4 TON VERTICAL SUPPLY

CFM	AVAILABLE EXTERNAL STATIC PRESSURE (in. wg)									
	0.2		0.4		0.6		0.8		1.0	
	RPM	BHP	RPM	BHP	RPM	BHP	RPM	BHP	RPM	BHP
	Standard Static Option					Medium Static Option				
1200	666	0.26	778	0.37	871	0.47	952	0.57	1025	0.67
1300	701	0.31	810	0.43	901	0.54	981	0.65	1053	0.76
1400	737	0.36	842	0.49	931	0.62	1010	0.74	1081	0.86
1500	773	0.42	875	0.57	963	0.70	1040	0.84	1110	0.96
1600	810	0.49	909	0.65	994	0.79	1070	0.94	1140	1.08
1700	847	0.57	943	0.73	1027	0.89	1101	1.05	1170	1.20
1800	885	0.66	978	0.83	1060	1.00	1133	1.16	1200	1.32
1900	923	0.75	1014	0.94	1093	1.11	1165	1.29	1231	1.46
2000	962	0.85	1049	1.05	1127	1.24	1198	1.42	1263	1.61

CFM	AVAILABLE EXTERNAL STATIC PRESSURE (in. wg)									
	1.2		1.4		1.6		1.8		2.0	
	RPM	BHP	RPM	BHP	RPM	BHP	RPM	BHP	RPM	BHP
	Medium Static Option					High Static Option				
1200	1093	0.77	1155	0.87	1213	0.96	1268	1.05	1321	1.14
1300	1119	0.87	1181	0.98	1239	1.08	1294	1.18	1346	1.28
1400	1147	0.98	1208	1.09	1265	1.21	1320	1.32	1371	1.43
1500	1175	1.09	1235	1.22	1292	1.34	1346	1.46	1397	1.58
1600	1204	1.21	1263	1.35	1320	1.48	1373	1.61	1424	1.74
1700	1233	1.34	1292	1.49	1348	1.63	1401	1.77	1451	1.91
1800	1262	1.48	1321	1.64	1376	1.79	1428	1.94	<b>1479</b>	<b>2.09</b>
1900	1293	1.63	1350	1.79	1405	1.96	1457	2.12	<b>1506</b>	<b>2.28</b>
2000	1323	1.79	1380	1.96	1434	2.13	<b>1486</b>	<b>2.31</b>	–	–

NOTE: For more information, see General Fan Performance Notes on page 60.

**Boldface** indicates field-supplied drive is required.

1. Recommend using field-supplied blower pulley (part no. 1175314), motor pulley (part no. 1170551) and belt (part no. 1178451).

Table 41 – RGS060, 1 PHASE, 5 TON HORIZONTAL SUPPLY

CFM	AVAILABLE EXTERNAL STATIC PRESSURE (in. wg)									
	0.2		0.4		0.6		0.8		1.0	
	RPM	BHP	RPM	BHP	RPM	BHP	RPM	BHP	RPM	BHP
	Standard Static Option									
1500	800	0.39	904	0.49	999	0.60	1087	0.72	1169	0.85
1625	849	0.48	947	0.59	1038	0.70	1122	0.83	1201	0.96
1750	899	0.59	992	0.70	1078	0.82	1159	0.95	1235	1.08
1875	950	0.70	1038	0.82	1120	0.95	1198	1.08	1271	1.22
2000	1001	0.84	1085	0.96	1163	1.09	1238	1.23	1309	1.38
2125	1053	0.99	1133	1.12	1208	1.26	1280	1.40	–	–
2250	1106	1.16	1182	1.29	1254	1.44	–	–	–	–
2375	1159	1.34	1231	1.49	–	–	–	–	–	–
2500	–	–	–	–	–	–	–	–	–	–

CFM	AVAILABLE EXTERNAL STATIC PRESSURE (in. wg)									
	1.2		1.4		1.6		1.8		2.0	
	RPM	BHP	RPM	BHP	RPM	BHP	RPM	BHP	RPM	BHP
	Medium Static Option									
1500	1247	0.98	1320	1.13	1390	1.28	1457	1.44	–	–
1625	1276	1.10	1348	1.24	1416	1.40	–	–	–	–
1750	1308	1.22	1377	1.38	–	–	–	–	–	–
1875	1342	1.37	–	–	–	–	–	–	–	–
2000	–	–	–	–	–	–	–	–	–	–
2125	–	–	–	–	–	–	–	–	–	–
2250	–	–	–	–	–	–	–	–	–	–
2375	–	–	–	–	–	–	–	–	–	–
2500	–	–	–	–	–	–	–	–	–	–

NOTE: For more information, see General Fan Performance Notes on page 60.

# FAN PERFORMANCE (cont.)

Table 42 – RGS060, 1 PHASE, 5 TON VERTICAL SUPPLY

CFM	AVAILABLE EXTERNAL STATIC PRESSURE (in. wg)									
	0.2		0.4		0.6		0.8		1.0	
	RPM	BHP	RPM	BHP	RPM	BHP	RPM	BHP	RPM	BHP
	Standard Static Option								Medium Static Option	
1500	848	0.42	968	0.55	1069	0.68	1158	0.80	1238	0.94
1625	897	0.51	1013	0.65	1111	0.79	1198	0.93	1277	1.07
1750	947	0.61	1059	0.76	1155	0.91	1240	1.06	1318	1.21
1875	997	0.72	1105	0.89	1199	1.05	1283	1.21	1359	1.37
2000	1048	0.85	1153	1.03	1244	1.20	1326	1.37	–	–
2125	1100	1.00	1201	1.19	1290	1.37	–	–	–	–
2250	1152	1.16	1250	1.36	–	–	–	–	–	–
2375	1205	1.34	–	–	–	–	–	–	–	–
2500	–	–	–	–	–	–	–	–	–	–

CFM	AVAILABLE EXTERNAL STATIC PRESSURE (in. wg)									
	1.2		1.4		1.6		1.8		2.0	
	RPM	BHP	RPM	BHP	RPM	BHP	RPM	BHP	RPM	BHP
	Medium Static Option						Field–Supplied Drive <sup>1</sup>			
1500	1312	1.07	1380	1.20	1445	1.34	1506	1.48	–	–
1625	1350	1.21	1418	1.35	1482	1.50	–	–	–	–
1750	1390	1.36	–	–	–	–	–	–	–	–
1875	–	–	–	–	–	–	–	–	–	–
2000	–	–	–	–	–	–	–	–	–	–
2125	–	–	–	–	–	–	–	–	–	–
2250	–	–	–	–	–	–	–	–	–	–
2375	–	–	–	–	–	–	–	–	–	–
2500	–	–	–	–	–	–	–	–	–	–

NOTE: For more information, see General Fan Performance Notes on page 60.

**Boldface** indicates field–supplied drive is required.

1. Recommend using field–supplied motor pulley (part number 1175494) and belt (part number 1177401).

Table 43 – RGS060, 3 PHASE, 5 TON HORIZONTAL SUPPLY

CFM	AVAILABLE EXTERNAL STATIC PRESSURE (in. wg)									
	0.2		0.4		0.6		0.8		1.0	
	RPM	BHP	RPM	BHP	RPM	BHP	RPM	BHP	RPM	BHP
	Standard Static Option									
1500	800	0.39	904	0.49	999	0.60	1087	0.72	1169	0.85
1625	849	0.48	947	0.59	1038	0.70	1122	0.83	1201	0.96
1750	899	0.59	992	0.70	1078	0.82	1159	0.95	1235	1.08
1875	950	0.70	1038	0.82	1120	0.95	1198	1.08	1271	1.22
2000	1001	0.84	1085	0.96	1163	1.09	1238	1.23	1309	1.38
2125	1053	0.99	1133	1.12	1208	1.26	1280	1.40	1348	1.55
2250	1106	1.16	1182	1.29	1254	1.44	1323	1.59	1389	1.74
2375	1159	1.34	1231	1.49	1300	1.64	1367	1.80	1430	1.96
2500	1212	1.55	1281	1.70	1348	1.86	1412	2.02	1473	2.19

CFM	AVAILABLE EXTERNAL STATIC PRESSURE (in. wg)									
	1.2		1.4		1.6		1.8		2.0	
	RPM	BHP	RPM	BHP	RPM	BHP	RPM	BHP	RPM	BHP
	Medium Static Option						High Static Option			
1500	1247	0.98	1320	1.13	1390	1.28	1457	1.44	1522	1.61
1625	1276	1.10	1348	1.24	1416	1.40	1481	1.56	1544	1.73
1750	1308	1.22	1377	1.38	1444	1.53	1507	1.70	1569	1.87
1875	1342	1.37	1409	1.52	1473	1.69	1536	1.86	1596	2.03
2000	1377	1.53	1442	1.69	1505	1.86	1565	2.03	1624	2.21
2125	1414	1.71	1477	1.87	1538	2.04	1597	2.22	1654	2.40
2250	1452	1.91	1514	2.08	1573	2.25	1630	2.43	1686	2.62
2375	1492	2.12	1551	2.30	1609	2.48	1665	2.66	1719	2.85
2500	1533	2.36	1591	2.54	1647	2.73	–	–	–	–

NOTE: For more information, see General Fan Performance Notes on page 60.

**Boldface** indicates field–supplied drive is required. Recommend using field–supplied fan pulley (part number 1175314) motor pulley (part no. 1178187), and belt (part number 1179766)



# FAN PERFORMANCE (cont.)

**Table 44 – RGS060, 3 PHASE, 5 TON VERTICAL SUPPLY**

CFM	AVAILABLE EXTERNAL STATIC PRESSURE (in. wg)									
	0.2		0.4		0.6		0.8		1.0	
	RPM	BHP	RPM	BHP	RPM	BHP	RPM	BHP	RPM	BHP
	Standard Static Option					Medium Static Option				
1500	848	0.42	968	0.55	1069	0.68	1158	0.80	1238	0.94
1625	897	0.51	1013	0.65	1111	0.79	1198	0.93	1277	1.07
1750	947	0.61	1059	0.76	1155	0.91	1240	1.06	1318	1.21
1875	997	0.72	1105	0.89	1199	1.05	1283	1.21	1359	1.37
2000	1048	0.85	1153	1.03	1244	1.20	1326	1.37	1401	1.54
2125	1100	1.00	1201	1.19	1290	1.37	1370	1.55	1444	1.73
2250	1152	1.16	1250	1.36	1336	1.55	1415	1.75	1487	1.94
2375	1205	1.34	1299	1.55	1384	1.76	1460	1.96	1532	2.17
2500	1258	1.54	1349	1.76	1431	1.98	1506	2.20	1576	2.41

CFM	AVAILABLE EXTERNAL STATIC PRESSURE (in. wg)									
	1.2		1.4		1.6		1.8		2.0	
	RPM	BHP	RPM	BHP	RPM	BHP	RPM	BHP	RPM	BHP
	Medium Static Option					High Static Option				
1500	1312	1.07	1380	1.20	1445	1.34	1506	1.48	1564	1.62
1625	1350	1.21	1418	1.35	1482	1.50	1542	1.64	1600	1.79
1750	1390	1.36	1457	1.51	1520	1.67	1580	1.83	1637	1.98
1875	1430	1.53	1496	1.69	1559	1.86	1618	2.02	1675	2.19
2000	1471	1.72	1536	1.89	1598	2.06	1657	2.24	1713	2.41
2125	1513	1.92	1577	2.10	1638	2.28	1696	2.47	1752	2.65
2250	1555	2.13	1619	2.33	1679	2.52	1736	2.72	1791	2.91
2375	1598	2.37	1661	2.57	1720	2.78	–	–	–	–
2500	1642	2.63	1704	2.84	–	–	–	–	–	–

**NOTE:** For more information, see General Fan Performance Notes on page 60.

**Boldface** indicates field-supplied drive is required. Recommend using field-supplied fan pulley (part number 1175314) motor pulley (part no. 1178187), and belt (part number 1179766)

**Table 45 – RGS072, 3 PHASE, 6 TON HORIZONTAL SUPPLY**

CFM	AVAILABLE EXTERNAL STATIC PRESSURE (in. wg)									
	0.2		0.4		0.6		0.8		1.0	
	RPM	BHP	RPM	BHP	RPM	BHP	RPM	BHP	RPM	BHP
	Field Supplied Drive <sup>1</sup>		Standard Static Option							
1800	913	0.64	1010	0.80	1098	0.98	1178	1.16	1252	1.35
1950	972	0.78	1065	0.96	1148	1.14	1226	1.34	1298	1.54
2100	1032	0.95	1120	1.14	1200	1.33	1275	1.54	1345	1.75
2250	1093	1.14	1177	1.34	1254	1.55	1325	1.76	1393	1.98
2400	1155	1.36	1234	1.57	1308	1.78	1377	2.01	1443	2.24
2550	1217	1.60	1293	1.82	1363	2.05	1430	2.28	1494	2.53
2700	1280	1.87	1352	2.10	1420	2.34	1484	2.59	1546	2.84
2850	1343	2.17	1412	2.42	1477	2.67	1539	2.93	1599	3.19
3000	1406	2.50	1472	2.76	1535	3.03	1595	3.29	1653	3.57

CFM	AVAILABLE EXTERNAL STATIC PRESSURE (in. wg)									
	1.2		1.4		1.6		1.8		2.0	
	RPM	BHP	RPM	BHP	RPM	BHP	RPM	BHP	RPM	BHP
	Standard Static Option					Medium Static Option			High Static Option	
1800	1322	1.56	1388	1.77	1451	1.98	1510	2.21	1568	2.44
1950	1366	1.75	1430	1.97	1491	2.20	1550	2.43	1606	2.67
2100	1411	1.97	1473	2.20	1533	2.43	1590	2.67	1645	2.92
2250	1457	2.21	1518	2.45	1576	2.69	1632	2.94	1686	3.20
2400	1505	2.48	1564	2.73	1621	2.98	1676	3.24	1729	3.51
2550	1554	2.78	1612	3.03	1667	3.30	1721	3.57	–	–
2700	1604	3.10	1660	3.37	1715	3.64	–	–	–	–
2850	1656	3.46	1710	3.74	–	–	–	–	–	–
3000	–	–	–	–	–	–	–	–	–	–

**NOTE:** For more information, see General Fan Performance Notes on page 60.

**Boldface** indicates field-supplied drive is required.

1. Recommend using field-supplied blower pulley (part no. 1175830), motor pulley (part no. 1175849) and belt (part no. 1178179).

# FAN PERFORMANCE (cont.)

Table 46 – RGS072, 3 PHASE, 6 TON VERTICAL SUPPLY

CFM	AVAILABLE EXTERNAL STATIC PRESSURE (in. wg)									
	0.2		0.4		0.6		0.8		1.0	
	RPM	BHP	RPM	BHP	RPM	BHP	RPM	BHP	RPM	BHP
	<b>Field-Supplied Drive<sup>1</sup></b>		<b>Standard Static Option</b>							
1800	967	0.63	1075	0.80	1170	0.97	1255	1.13	1333	1.28
1950	1029	0.77	1132	0.96	1223	1.14	1306	1.32	1382	1.49
2100	1091	0.93	1189	1.14	1278	1.33	1358	1.52	1433	1.71
2250	1154	1.11	1248	1.33	1333	1.55	1411	1.75	1484	1.96
2400	1218	1.32	1308	1.55	1390	1.78	1466	2.01	1537	2.23
2550	1283	1.55	1369	1.80	1448	2.05	1521	2.29	1590	2.52
2700	1348	1.80	1431	2.07	1507	2.33	1578	2.59	1645	2.84
2850	1414	2.09	1493	2.37	1566	2.65	1636	2.92	1701	3.19
3000	1479	2.40	1556	2.70	1627	3.00	1694	3.29	1757	3.57

CFM	AVAILABLE EXTERNAL STATIC PRESSURE (in. wg)									
	1.2		1.4		1.6		1.8		2.0	
	RPM	BHP	RPM	BHP	RPM	BHP	RPM	BHP	RPM	BHP
	<b>Medium Static Option</b>					<b>High Static Option</b>				
1800	1406	1.43	1475	1.58	1540	1.72	1601	1.87	1660	2.00
1950	1454	1.65	1521	1.82	1585	1.98	1645	2.13	1703	2.29
2100	1502	1.89	1568	2.07	1631	2.25	1690	2.42	1747	2.59
2250	1552	2.15	1617	2.35	1678	2.54	1737	2.73		
2400	1603	2.44	1666	2.65	1727	2.86	1784	3.06		
2550	1655	2.75	1717	2.98	1776	3.20				
2700	1709	3.09	1769	3.33	1827	3.57				
2850	1763	3.45								
3000										

NOTE: For more information, see General Fan Performance Notes on page 60.

**Boldface** indicates field-supplied drive is required.

1. Recommend using field-supplied blower pulley (part no. 1175830), motor pulley (part no. 1175849) and belt (part no. 1178179).
2. Recommend using field-supplied blower pulley (part no. 1175314), motor pulley (part no. ?) and belt (part no. ?).

Table 47 – RGS090 / 091, 3 PHASE, 7.5 TON HORIZONTAL SUPPLY

CFM	AVAILABLE EXTERNAL STATIC PRESSURE (in. wg)									
	0.2		0.4		0.6		0.8		1.0	
	RPM	BHP	RPM	BHP	RPM	BHP	RPM	BHP	RPM	BHP
	<b>Standard Static Option</b>						<b>Medium Static Option</b>			
2250	505	0.52	586	0.73	657	0.97	722	1.22	782	1.50
2438	533	0.62	610	0.85	679	1.09	742	1.36	800	1.65
2625	562	0.74	635	0.98	701	1.23	762	1.51	819	1.81
2813	591	0.88	661	1.13	725	1.39	783	1.68	839	1.98
3000	621	1.03	688	1.29	749	1.57	806	1.87	859	2.18
3188	652	1.21	715	1.48	774	1.77	829	2.07	881	2.40
3375	682	1.40	743	1.68	800	1.98	853	2.30	903	2.63
3563	713	1.61	772	1.91	826	2.22	878	2.55	927	2.89
3750	745	1.85	801	2.15	853	2.48	903	2.82	951	3.18

CFM	AVAILABLE EXTERNAL STATIC PRESSURE (in. wg)									
	1.2		1.4		1.6		1.8		2.0	
	RPM	BHP	RPM	BHP	RPM	BHP	RPM	BHP	RPM	BHP
	<b>Medium Static Option</b>					<b>High Static Option</b>				
2250	838	1.81	891	2.12	941	2.46	988	2.82	1033	3.19
2438	854	1.96	906	2.28	955	2.63	1001	2.99	1046	3.37
2625	872	2.12	922	2.46	970	2.81	1016	3.17	1060	3.56
2813	890	2.31	940	2.65	986	3.01	1031	3.38	1074	3.77
3000	910	2.51	958	2.86	1004	3.23	1048	3.61	1090	4.01
3188	930	2.74	977	3.10	1022	3.47	1065	3.86	<b>1107</b>	<b>4.26<sup>1</sup></b>
3375	951	2.99	997	3.35	1041	3.74	1083	4.13	<b>1124</b>	<b>4.54</b>
3563	973	3.26	1018	3.63	1061	4.02	1103	4.43		
3750	996	3.55	1040	3.93	1082	4.34				

NOTE: For more information, see General Fan Performance Notes on page 60.

**Boldface** indicates field-supplied drive is required.

- <sup>1</sup> Recommend using field-supplied blower pulley (part no. 1175896), and belt (part no. 1178182).

# FAN PERFORMANCE (cont.)

Table 48 – RGS090 / 091, 3 PHASE, 7.5 TON VERTICAL SUPPLY

CFM	AVAILABLE EXTERNAL STATIC PRESSURE (in. wg)									
	0.2		0.4		0.6		0.8		1.0	
	RPM	BHP	RPM	BHP	RPM	BHP	RPM	BHP	RPM	BHP
	Standard Static Option								Medium Static Option	
2250	513	0.54	595	0.76	665	1.01	728	1.27	786	1.56
2438	541	0.65	620	0.89	688	1.14	750	1.42	806	1.71
2625	570	0.77	645	1.02	712	1.29	772	1.58	827	1.88
2813	600	0.91	672	1.18	736	1.46	794	1.76	848	2.07
3000	629	1.07	699	1.35	761	1.64	818	1.95	871	2.28
3188	660	1.25	726	1.54	787	1.85	842	2.17	894	2.51
3375	690	1.45	754	1.75	813	2.07	867	2.41	917	2.76
3563	721	1.67	783	1.98	840	2.32	892	2.67	941	3.03
3750	752	1.91	812	2.24	867	2.59	918	2.95	966	3.32

CFM	AVAILABLE EXTERNAL STATIC PRESSURE (in. wg)									
	1.2		1.4		1.6		1.8		2.0	
	RPM	BHP	RPM	BHP	RPM	BHP	RPM	BHP	RPM	BHP
	Medium Static Option					High Static Option				
2250	839	1.86	889	2.18	935	2.52	980	2.87	1022	3.23
2438	858	2.02	907	2.35	953	2.70	997	3.06	1039	3.43
2625	878	2.20	926	2.54	972	2.89	1015	3.26	1056	3.64
2813	899	2.40	946	2.75	991	3.11	1033	3.49	1074	3.88
3000	920	2.62	966	2.98	1010	3.35	1052	3.74	1093	4.14
3188	942	2.86	987	3.23	1031	3.61	1072	4.01	1112	4.42 <sup>1</sup>
3375	964	3.12	1009	3.50	1052	3.89	1093	4.30	–	–
3563	988	3.41	1032	3.80	1074	4.20	1114	4.61	–	–
3750	1011	3.71	1054	4.11	1096	4.53	–	–	–	–

NOTE: For more information, see General Fan Performance Notes on page 60.

**Boldface** indicates field-supplied drive is required.

<sup>1</sup> Recommend using field-supplied blower pulley (part no. 1175896), and belt (part no. 1178182).

Table 49 – RGS101 / 102, 3 PHASE, 8.5 TON HORIZONTAL SUPPLY

CFM	AVAILABLE EXTERNAL STATIC PRESSURE (in. wg)									
	0.2		0.4		0.6		0.8		1.0	
	RPM	BHP	RPM	BHP	RPM	BHP	RPM	BHP	RPM	BHP
	Standard Static Option								Medium Static Option	
2550	497	0.48	579	0.61	651	0.75	717	0.90	777	1.05
2763	524	0.58	602	0.72	671	0.87	735	1.03	794	1.19
2975	551	0.70	626	0.86	693	1.01	754	1.18	812	1.35
3188	580	0.84	651	1.00	716	1.17	775	1.34	831	1.52
3400	609	1.00	677	1.17	739	1.35	797	1.53	851	1.71
3613	638	1.17	703	1.35	763	1.54	819	1.73	871	1.93
3825	668	1.37	730	1.56	788	1.76	842	1.96	893	2.16
4038	698	1.59	758	1.79	813	2.00	866	2.20	915	2.42
4250	728	1.83	786	2.04	839	2.26	890	2.47	938	2.70

CFM	AVAILABLE EXTERNAL STATIC PRESSURE (in. wg)									
	1.2		1.4		1.6		1.8		2.0	
	RPM	BHP	RPM	BHP	RPM	BHP	RPM	BHP	RPM	BHP
	Medium Static Option					High Static Option				
2550	833	1.21	886	1.38	936	1.56	984	1.74	1029	1.93
2763	849	1.36	900	1.53	950	1.72	996	1.90	1041	2.10
2975	865	1.52	916	1.70	964	1.89	1010	2.09	1054	2.29
3188	883	1.70	933	1.89	980	2.09	1025	2.29	1068	2.50
3400	902	1.90	950	2.10	996	2.30	1041	2.51	1083	2.73
3613	921	2.13	969	2.33	1014	2.54	1057	2.76	1099	2.98 <sup>2</sup>
3825	941	2.37	988	2.58	1032	2.80	1075	3.02	1116	3.25
4038	963	2.63	1008	2.86	1051	3.08	1093	3.31	1133	3.55
4250	984	2.92	1029	3.15	1071	3.39	1112	3.63	–	–

NOTE: For more information, see General Fan Performance Notes on page 60.

**Boldface** indicates field-supplied drive is required.

<sup>1</sup> Recommend using field-supplied blower pulley (part no. 1178189), belt (part no. 1178450).

<sup>2</sup> Recommend using field-supplied motor pulley (part no. 1178133), fan pulley (part no. 1178596) belt (part no. 1178182)

# FAN PERFORMANCE (cont.)

Table 50 – RGS101 / 102, 3 PHASE, 8.5 TON VERTICAL SUPPLY

CFM	AVAILABLE EXTERNAL STATIC PRESSURE (in. wg)									
	0.2		0.4		0.6		0.8		1.0	
	RPM	BHP	RPM	BHP	RPM	BHP	RPM	BHP	RPM	BHP
	Standard Static Option								Medium Static Option	
2550	526	0.51	600	0.65	666	0.79	727	0.93	783	1.07
2763	557	0.62	627	0.77	690	0.92	749	1.08	804	1.23
2975	588	0.75	655	0.91	716	1.08	772	1.24	825	1.40
3188	621	0.90	684	1.07	743	1.25	797	1.42	848	1.60
3400	653	1.06	714	1.25	770	1.44	822	1.62	872	1.81
3613	687	1.25	744	1.45	798	1.65	849	1.84	897	2.04
3825	720	1.45	775	1.67	827	1.88	876	2.09	922	2.30
4038	754	1.69	807	1.91	856	2.13	904	2.35	949	2.57
4250	788	1.94	839	2.17	886	2.41	932	2.64	976	2.88

CFM	AVAILABLE EXTERNAL STATIC PRESSURE (in. wg)									
	1.2		1.4		1.6		1.8		2.0	
	RPM	BHP	RPM	BHP	RPM	BHP	RPM	BHP	RPM	BHP
	Medium Static Option					High Static Option				
2550	836	1.20	886	1.34	934	1.48	979	1.61	1022	1.74
2763	855	1.37	904	1.52	950	1.67	995	1.82	1037	1.97
2975	875	1.56	923	1.72	968	1.88	1012	2.04	1053	2.20
3188	897	1.77	943	1.94	987	2.11	1030	2.29	1071	2.46
3400	919	1.99	964	2.18	1007	2.36	1049	2.55	<b>1089</b>	<b>2.73<sup>1</sup></b>
3613	943	2.24	986	2.44	1029	2.63	1069	2.83	<b>1108</b>	<b>3.02</b>
3825	967	2.51	1010	2.71	1051	2.92	<b>1090</b>	<b>3.13</b>	<b>1129</b>	<b>3.34</b>
4038	992	2.80	1034	3.02	1074	3.24	<b>1112</b>	<b>3.46</b>	<b>1150</b>	<b>3.68</b>
4250	1018	3.11	1058	3.34	<b>1097</b>	<b>3.57</b>	–	–	–	–

NOTE: For more information, see General Fan Performance Notes on page 60.

**Boldface** indicates field-supplied drive is required.

<sup>1</sup> Recommend using field-supplied motor pulley (part number 1178133), fan pulley (part no.1175896) and belt (part no. 1178182)

Table 51 – RGS120 / 121, 3 PHASE, 10 TON HORIZONTAL SUPPLY

CFM	AVAILABLE EXTERNAL STATIC PRESSURE (in. wg)									
	0.2		0.4		0.6		0.8		1.0	
	RPM	BHP	RPM	BHP	RPM	BHP	RPM	BHP	RPM	BHP
	Standard Static Option								Medium Static Option	
3000	579	0.70	660	0.89	732	1.09	799	1.29	860	1.50
3250	613	0.85	690	1.06	760	1.27	823	1.49	883	1.71
3500	648	1.03	721	1.25	788	1.48	850	1.71	907	1.95
3750	683	1.23	753	1.47	817	1.71	877	1.96	933	2.21
4000	719	1.45	786	1.71	848	1.97	905	2.23	959	2.50
4250	756	1.71	819	1.98	879	2.26	934	2.53	987	2.81
4500	792	1.99	853	2.28	910	2.57	964	2.87	1015	3.16
4750	830	2.31	888	2.62	943	2.92	995	3.23	1044	3.54
5000	867	2.66	923	2.98	976	3.30	1026	3.63	1074	3.95

CFM	AVAILABLE EXTERNAL STATIC PRESSURE (in. wg)									
	1.2		1.4		1.6		1.8		2.0	
	RPM	BHP	RPM	BHP	RPM	BHP	RPM	BHP	RPM	BHP
	Medium Static Option					High Static Option				
3000	917	1.70	970	1.91	1021	2.13	1070	2.34	1117	2.56
3250	938	1.93	991	2.16	1041	2.38	1089	2.61	1134	2.85
3500	961	2.18	1013	2.42	1062	2.66	1108	2.91	1153	3.15
3750	985	2.46	1035	2.71	1083	2.97	1129	3.23	1173	3.49
4000	1011	2.76	1059	3.03	1106	3.30	1151	3.58	1194	3.85
4250	1037	3.09	1084	3.38	1130	3.66	1174	3.95	1216	4.24
4500	1064	3.46	1110	3.76	1155	4.06	1198	4.36	1239	4.66
4750	1091	3.85	1137	4.16	1180	4.48	–	–	–	–
5000	1120	4.28	1164	4.61	–	–	–	–	–	–

NOTE: For more information, see General Fan Performance Notes on page 60.

**Boldface** indicates field-supplied drive is required.

<sup>1</sup> Recommend using field-supplied blower pulley (part no. 1178190), and belt (part no. 1178181).

## FAN PERFORMANCE (cont.)

**Table 52 – RGS120 / 121, 3 PHASE, 10 TON VERTICAL SUPPLY**

CFM	AVAILABLE EXTERNAL STATIC PRESSURE (in. wg)									
	0.2		0.4		0.6		0.8		1.0	
	RPM	BHP	RPM	BHP	RPM	BHP	RPM	BHP	RPM	BHP
	Standard Static Option								Medium Static Option	
3000	616	0.79	689	0.97	757	1.16	821	1.36	882	1.57
3250	655	0.96	724	1.16	788	1.37	849	1.58	907	1.80
3500	695	1.17	760	1.38	821	1.60	879	1.83	934	2.06
3750	736	1.41	797	1.63	855	1.86	910	2.10	963	2.35
4000	777	1.68	834	1.91	889	2.16	942	2.41	993	2.67
4250	818	1.98	873	2.23	925	2.49	976	2.75	1025	3.02
4500	860	2.32	912	2.58	962	2.85	1010	3.13	1057	3.41
4750	902	2.69	951	2.97	999	3.26	1046	3.55	1091	3.84
5000	944	3.11	991	3.40	1037	3.70	1082	4.00	1125	4.31

CFM	AVAILABLE EXTERNAL STATIC PRESSURE (in. wg)									
	1.2		1.4		1.6		1.8		2.0	
	RPM	BHP	RPM	BHP	RPM	BHP	RPM	BHP	RPM	BHP
	Medium Static Option					High Static Option				
3000	939	1.79	994	2.01	1047	2.24	1098	2.47	1147	2.71
3250	962	2.03	1015	2.26	1066	2.50	1115	2.75	1163	3.00
3500	987	2.30	1038	2.54	1088	2.80	1135	3.05	1181	3.32
3750	1014	2.60	1063	2.86	1111	3.12	1157	3.39	1202	3.66
4000	1042	2.93	1090	3.20	1136	3.48	1180	3.76	1224	4.04
4250	1072	3.30	1118	3.58	1162	3.87	1205	4.16	<b>1247</b>	<b>4.46</b>
4500	1103	3.70	1147	4.00	1190	4.29	1232	4.60	–	–
4750	1135	4.14	1177	4.45	–	–	–	–	–	–
5000	1167	4.63	–	–	–	–	–	–	–	–

NOTE: For more information, see General Fan Performance Notes on page 60.

**Table 53 – RGS150, 3 PHASE, 12.5 TON HORIZONTAL SUPPLY**

CFM	AVAILABLE EXTERNAL STATIC PRESSURE (in. wg)									
	0.2		0.4		0.6		0.8		1.0	
	RPM	BHP	RPM	BHP	RPM	BHP	RPM	BHP	RPM	BHP
	Standard Static Option								Medium Static Option	
3438	639	0.98	713	1.20	781	1.43	843	1.65	901	1.88
3750	683	1.23	753	1.47	817	1.71	877	1.96	933	2.21
4063	728	1.52	794	1.78	855	2.04	912	2.31	966	2.57
4375	774	1.85	836	2.13	894	2.41	949	2.70	1001	2.98
4688	820	2.23	879	2.53	935	2.83	987	3.14	1037	3.44
5000	867	2.66	923	2.98	976	3.30	1026	3.63	1074	3.95
5313	914	3.15	967	3.49	<b>1018</b>	<b>3.83</b>	1066	4.17	1112	4.52
5625	962	3.69	<b>1012</b>	<b>4.05</b>	1061	4.42	–	–	–	–
5938	<b>1009</b>	<b>4.30</b>	1058	4.68	–	–	–	–	–	–
6250	–	–	–	–	–	–	–	–	–	–

CFM	AVAILABLE EXTERNAL STATIC PRESSURE (in. wg)									
	1.2		1.4		1.6		1.8		2.0	
	RPM	BHP	RPM	BHP	RPM	BHP	RPM	BHP	RPM	BHP
	Medium Static Option					High Static Option				
3438	955	2.12	1007	2.35	1056	2.59	1103	2.83	1148	3.08
3750	985	2.46	1035	2.71	1083	2.97	1129	3.23	1173	3.49
4063	1017	2.84	1066	3.12	1112	3.39	1157	3.67	1200	3.95
4375	1050	3.27	1097	3.56	1142	3.86	1186	4.15	1228	4.45
4688	1084	3.75	1130	4.06	1174	4.37	1216	4.68	–	–
5000	1120	4.28	1164	4.61	–	–	–	–	–	–
5313	–	–	–	–	–	–	–	–	–	–
5625	–	–	–	–	–	–	–	–	–	–
5938	–	–	–	–	–	–	–	–	–	–
6250	–	–	–	–	–	–	–	–	–	–

NOTE: For more information, see General Fan Performance Notes on page 60.

**Boldface** indicates field supplied drive is required.

# FAN PERFORMANCE (cont.)

Table 54 – RGS150, 3 PHASE, 12.5 TON VERTICAL SUPPLY

CFM	AVAILABLE EXTERNAL STATIC PRESSURE (in. wg)									
	0.2		0.4		0.6		0.8		1.0	
	RPM	BHP	RPM	BHP	RPM	BHP	RPM	BHP	RPM	BHP
	Standard Static Option					Medium Static Option				
3438	685	1.12	751	1.32	813	1.54	871	1.76	927	1.99
3750	736	1.41	797	1.63	855	1.86	910	2.10	963	2.35
4063	787	1.75	844	1.99	898	2.24	951	2.49	1001	2.75
4375	839	2.14	892	2.40	943	2.67	993	2.94	1041	3.21
4688	891	2.60	941	2.87	990	3.15	1037	3.44	1082	3.73
5000	944	3.11	991	3.40	1037	3.70	1082	4.00	1125	4.31
5313	997	3.69	1042	4.00	1085	4.32	1128	4.64	–	–
5625	1051	4.34	1093	4.67	–	–	–	–	–	–
5938	–	–	–	–	–	–	–	–	–	–
6250	–	–	–	–	–	–	–	–	–	–

CFM	AVAILABLE EXTERNAL STATIC PRESSURE (in. wg)									
	1.2		1.4		1.6		1.8		2.0	
	RPM	BHP	RPM	BHP	RPM	BHP	RPM	BHP	RPM	BHP
	Medium Static Option					High Static Option				
3438	981	2.23	1032	2.47	1082	2.72	1130	2.97	1177	3.23
3750	1014	2.60	1063	2.86	1111	3.12	1157	3.39	1202	3.66
4063	1049	3.02	1097	3.29	1142	3.57	1186	3.85	1230	4.14
4375	1087	3.49	1132	3.78	1176	4.08	1218	4.37	1260	4.68
4688	1126	4.03	1169	4.33	1211	4.64	–	–	–	–
5000	1167	4.63	–	–	–	–	–	–	–	–
5313	–	–	–	–	–	–	–	–	–	–
5625	–	–	–	–	–	–	–	–	–	–
5938	–	–	–	–	–	–	–	–	–	–
6250	–	–	–	–	–	–	–	–	–	–

NOTE: For more information, see General Fan Performance Notes on page 60.

**Boldface** indicates field supplied drive is required.

Table 55 – RGS180, 3 PHASE, 15 TON HORIZONTAL SUPPLY

CFM	Available External Static Pressure (in. wg)									
	0.2		0.4		0.6		0.8		1.0	
	RPM	BHP	RPM	BHP	RPM	BHP	RPM	BHP	RPM	BHP
4500	479	0.97	540	1.23	596	1.50	651	1.80	703	2.13
4875	508	1.19	566	1.47	619	1.75	670	2.06	719	2.39
5250	537	1.43	592	1.73	643	2.03	691	2.35	737	2.69
5625	566	1.71	619	2.03	667	2.35	713	2.68	757	3.03
6000	596	2.02	646	2.36	692	2.70	736	3.05	778	3.41
6375	625	2.36	674	2.73	718	3.09	760	3.46	800	3.83
6750	655	2.75	701	3.14	744	3.52	785	3.91	824	4.30
7125	685	3.17	729	3.58	771	3.99	810	4.40	848	4.81
7500	715	3.64	758	4.07	798	4.50	836	4.93	872	5.36

CFM	Available External Static Pressure (in. wg)									
	1.2		1.4		1.6		1.8		2.0	
	RPM	BHP	RPM	BHP	RPM	BHP	RPM	BHP	RPM	BHP
4500	755	2.48	805	2.87	853	3.28	900	3.72	945	4.17
4875	768	2.75	815	3.14	862	3.55	907	3.99	951	4.45
5250	783	3.06	828	3.45	872	3.86	916	4.30	958	4.77
5625	800	3.40	843	3.80	885	4.21	926	4.66	967	5.12
6000	819	3.79	860	4.19	900	4.61	939	5.06	978	5.53
6375	840	4.23	878	4.63	916	5.06	954	5.51	991	5.98
6750	861	4.70	898	5.12	935	5.56	971	6.01	–	–
7125	884	5.23	919	5.66	–	–	–	–	–	–
7500	907	5.79	–	–	–	–	–	–	–	–

NOTE: For more information, see General Fan Performance Notes on page 60.

**Boldface** indicates field supplied drive is required.

# FAN PERFORMANCE (cont.)

Table 56 – RGS180, 3 PHASE, 15 TON VERTICAL SUPPLY

CFM	Available External Static Pressure (in. wg)									
	0.2		0.4		0.6		0.8		1.0	
	RPM	BHP	RPM	BHP	RPM	BHP	RPM	BHP	RPM	BHP
4500	487	0.98	552	1.26	610	1.55	665	1.86	718	2.20
4875	515	1.18	578	1.49	633	1.80	685	2.13	735	2.47
5250	544	1.42	604	1.75	657	2.09	707	2.43	754	2.78
5625	572	1.68	631	2.05	682	2.40	730	2.76	775	3.13
6000	601	1.98	657	2.37	707	2.75	753	3.13	797	3.52
6375	630	2.31	684	2.73	733	3.13	777	3.53	819	3.94
6750	659	2.68	711	3.12	759	3.55	802	3.98	843	4.40
7125	689	3.09	739	3.55	785	4.01	827	4.46	867	4.91
7500	718	3.53	<b>766</b>	<b>4.02</b>	811	4.51	852	4.98	891	5.46

CFM	Available External Static Pressure (in. wg)									
	1.2		1.4		1.6		1.8		2.0	
	RPM	BHP	RPM	BHP	RPM	BHP	RPM	BHP	RPM	BHP
4500	769	2.56	819	2.95	866	3.36	912	3.79	957	4.24
4875	784	2.84	831	3.23	877	3.65	921	4.09	<b>964</b>	<b>4.54</b>
5250	800	3.16	845	3.56	889	3.98	932	4.43	<b>974</b>	<b>4.89</b>
5625	819	3.52	862	3.93	903	4.36	944	4.81	<b>985</b>	<b>5.28</b>
6000	839	3.92	880	4.34	920	4.77	<b>959</b>	<b>5.23</b>	<b>997</b>	<b>5.70</b>
6375	860	4.36	899	4.79	937	5.23	<b>975</b>	<b>5.70</b>	–	–
6750	882	4.84	920	5.28	957	5.74	–	–	–	–
7125	904	5.36	941	5.82	–	–	–	–	–	–
7500	928	5.93	–	–	–	–	–	–	–	–

**NOTE:** For more information, see General Fan Performance Notes on page 60.

**Boldface** indicates field supplied drive is required.

# FAN PERFORMANCE (cont.)

**Table 57 – PULLEY ADJUSTMENT**

UNIT RGS		MOTOR/DRIVE COMBO	MOTOR PULLEY TURNS OPEN										
			0.0	0.5	1.0	1.5	2.0	2.5	3.0	3.5	4.0	4.5	5.0
036	1 phase	Standard Static	854	825	795	766	736	707	678	648	619	589	560
		Medium Static	1175	1135	1094	1054	1013	973	932	892	851	811	770
		High Static	–	–	–	–	–	–	–	–	–	–	–
	3 phase	Standard Static	854	825	795	766	736	707	678	648	619	589	560
		Medium Static	1175	1135	1094	1054	1013	973	932	892	851	811	770
		High Static	1466	1423	1380	1337	1294	1251	1207	1164	1121	1078	1035
048	1 phase	Standard Static	854	825	795	766	736	707	678	648	619	589	560
		Medium Static	1175	1135	1094	1054	1013	973	932	892	851	811	770
		High Static	–	–	–	–	–	–	–	–	–	–	–
	3 phase	Standard Static	854	825	795	766	736	707	678	648	619	589	560
		Medium Static	1175	1135	1094	1054	1013	973	932	892	851	811	770
		High Static	1466	1423	1380	1337	1294	1251	1207	1164	1121	1078	1035
060	1 phase	Standard Static	1175	1135	1094	1054	1013	973	932	892	851	811	770
		Medium Static	1466	1423	1380	1337	1294	1251	1207	1164	1121	1078	1035
		High Static	–	–	–	–	–	–	–	–	–	–	–
	3 phase	Standard Static	1175	1135	1094	1054	1013	973	932	892	851	811	770
		Medium Static	1466	1423	1380	1337	1294	1251	1207	1164	1121	1078	1035
		High Static	1687	1649	1610	1572	1533	1495	1457	1418	1380	1341	1303
072	3 phase	Standard Static	1457	1419	1380	1342	1303	1265	1227	1188	1150	1111	1073
		Medium Static	1518	1484	1449	1415	1380	1346	1311	1277	1242	1208	1173
		High Static	1788	1757	1725	1694	1662	1631	1600	1568	1537	1505	1474
090/091	3 phase	Standard Static	747	721	695	670	644	618	592	566	541	515	489
		Medium Static	949	927	906	884	863	841	819	798	776	755	733
		High Static	1102	1083	1063	1044	1025	1006	986	967	948	928	909
101/102	3 phase	Standard Static	733	712	690	669	647	626	604	583	561	540	518
		Medium Static	936	911	887	862	838	813	788	764	739	715	690
		High Static	1084	1059	1035	1010	986	961	936	912	887	863	838
120/121	3 phase	Standard Static	838	813	789	764	739	715	690	665	640	616	591
		Medium Static	1084	1059	1035	1010	986	961	936	912	887	863	838
		High Static	1240	1218	1196	1175	1153	1131	1109	1087	1066	1044	1022
150	3 phase	Standard Static	843	824	805	786	767	748	728	709	690	671	652
		Medium Static	1084	1059	1035	1010	986	961	936	912	887	863	838
		High Static	1240	1218	1196	1175	1153	1131	1109	1087	1066	1044	1022
180	3 phase	Standard Static	676	659	642	625	608	592	575	558	541	524	507
		Medium Static	851	829	806	784	761	739	717	694	672	649	627
		High Static	955	937	919	901	883	866	848	830	812	794	776



## FAN PERFORMANCE (cont.)

UNIT RGS		MOTOR/DRIVE COMBO	MOTOR PULLEY TURNS OPEN										
			0.0	0.5	1.0	1.5	2.0	2.5	3.0	3.5	4.0	4.5	5.0
036	1 phase	Standard Static	854	825	795	766	736	707	678	648	619	589	560
		Medium Static	1175	1135	1094	1054	1013	973	932	892	851	811	770
		High Static	-	-	-	-	-	-	-	-	-	-	-
	3 phase	Standard Static	854	825	795	766	736	707	678	648	619	589	560
		Medium Static	1175	1135	1094	1054	1013	973	932	892	851	811	770
		High Static	1466	1423	1380	1337	1294	1251	1207	1164	1121	1078	1035
048	1 phase	Standard Static	854	825	795	766	736	707	678	648	619	589	560
		Medium Static	1175	1135	1094	1054	1013	973	932	892	851	811	770
		High Static	-	-	-	-	-	-	-	-	-	-	-
	3 phase	Standard Static	854	825	795	766	736	707	678	648	619	589	560
		Medium Static	1175	1135	1094	1054	1013	973	932	892	851	811	770
		High Static	1466	1423	1380	1337	1294	1251	1207	1164	1121	1078	1035
060	1 phase	Standard Static	1175	1135	1094	1054	1013	973	932	892	851	811	770
		Medium Static	1466	1423	1380	1337	1294	1251	1207	1164	1121	1078	1035
		High Static	-	-	-	-	-	-	-	-	-	-	-
	3 phase	Standard Static	1175	1135	1094	1054	1013	973	932	892	851	811	770
		Medium Static	1466	1423	1380	1337	1294	1251	1207	1164	1121	1078	1035
		High Static	1687	1649	1610	1572	1533	1495	1457	1418	1380	1341	1303
072	3 phase	Standard Static	1457	1419	1380	1342	1303	1265	1227	1188	1150	1111	1073
		Medium Static	1518	1484	1449	1415	1380	1346	1311	1277	1242	1208	1173
		High Static	1788	1757	1725	1694	1662	1631	1600	1568	1537	1505	1474
090/091	3 phase	Standard Static	747	721	695	670	644	618	592	566	541	515	489
		Medium Static	949	927	906	884	863	841	819	798	776	755	733
		High Static	1102	1083	1063	1044	1025	1006	986	967	948	928	909
101/102	3 phase	Standard Static	733	712	690	669	647	626	604	583	561	540	518
		Medium Static	936	911	887	862	838	813	788	764	739	715	690
		High Static	1084	1059	1035	1010	986	961	936	912	887	863	838
120/121	3 phase	Standard Static	838	813	789	764	739	715	690	665	640	616	591
		Medium Static	1084	1059	1035	1010	986	961	936	912	887	863	838
		High Static	1240	1218	1196	1175	1153	1131	1109	1087	1066	1044	1022
150	3 phase	Standard Static	843	824	805	786	767	748	728	709	690	671	652
		Medium Static	1084	1059	1035	1010	986	961	936	912	887	863	838
		High Static	1240	1218	1196	1175	1153	1131	1109	1087	1066	1044	1022
180	3 phase	Standard Static	676	659	642	625	608	592	575	558	541	524	507
		Medium Static	851	829	806	784	761	739	717	694	672	649	627
		High Static	955	937	919	901	883	866	848	830	812	794	776

**NOTE:** Do not adjust pulley further than 5 turns open.

■ – Factory settings

# ELECTRICAL INFORMATION

**Table 58 – RGS036, SINGLE STAGE COOLING WITH SINGLE SPEED INDOOR FAN MOTOR, 3 TONS**

V-Ph-Hz	VOLTAGE RANGE		COMP (ea)		OFM (ea)		IFM		
	MIN	MAX	RLA	LRA	WATTS	FLA	TYPE	EFF at Full Load	FLA
208-1-60	187	253	16.6	79	325	1.5	STD	67%	4.9
					325	1.5	MED	67%	4.9
230-1-60	187	253	16.6	79	325	1.5	STD	67%	4.9
					325	1.5	MED	67%	4.9
208-3-60	187	253	10.4	73	325	1.5	STD	75%	5.2
					325	1.5	MED	75%	5.2
					325	1.5	HIGH	87%	6.9
230-3-60	187	253	10.4	73	325	1.5	STD	75%	5.2
					325	1.5	MED	75%	5.2
					325	1.5	HIGH	87%	6.7
460-3-60	414	506	5.8	38	325	0.8	STD	75%	2.6
					325	0.8	MED	75%	2.6
					325	0.8	HIGH	87%	3.4
575-3-60	518	633	3.8	37	325	0.6	STD	73%	2.4
					325	0.6	MED	73%	2.4
					325	0.6	HIGH	78%	2.0

**Table 59 – RGS048, SINGLE STAGE COOLING WITH SINGLE SPEED INDOOR FAN MOTOR, 4 TONS**

V-Ph-Hz	VOLTAGE RANGE		COMP (ea)		OFM (ea)		IFM		
	MIN	MAX	RLA	LRA	WATTS	FLA	TYPE	EFF at Full Load	FLA
208-1-60	187	253	21.8	117	325	1.5	STD	67%	4.9
					325	1.5	MED	67%	4.9
230-1-60	187	253	21.8	117	325	1.5	STD	67%	4.9
					325	1.5	MED	67%	4.9
208-3-60	187	253	13.7	83	325	1.5	STD	75%	5.2
					325	1.5	MED	75%	5.2
					325	1.5	HIGH	87%	6.9
230-3-60	187	253	13.7	83	325	1.5	STD	75%	5.2
					325	1.5	MED	75%	5.2
					325	1.5	HIGH	87%	6.7
460-3-60	414	506	6.2	41	325	0.8	STD	75%	2.6
					325	0.8	MED	75%	2.6
					325	0.8	HIGH	87%	3.4
575-3-60	518	633	4.8	33	325	0.6	STD	73%	2.4
					325	0.6	MED	73%	2.4
					325	0.6	HIGH	78%	2.0

**Table 60 – RGS060, SINGLE STAGE COOLING WITH SINGLE SPEED INDOOR FAN MOTOR, 5 TONS**

V-Ph-Hz	VOLTAGE RANGE		COMP (ea)		OFM (ea)		IFM		
	MIN	MAX	RLA	LRA	WATTS	FLA	TYPE	EFF at Full Load	FLA
208-1-60	187	253	26.2	134	325	1.5	STD	67%	4.9
					325	1.5	MED	76%	7.0
230-1-60	187	253	26.2	134	325	1.5	STD	67%	4.9
					325	1.5	MED	76%	7.0
208-3-60	187	253	15.6	110	325	1.5	STD	75%	5.2
					325	1.5	MED	87%	6.9
					325	1.5	HIGH	89%	8.4
230-3-60	187	253	15.6	110	325	1.5	STD	75%	5.2
					325	1.5	MED	87%	6.7
					325	1.5	HIGH	89%	8.3
460-3-60	414	506	7.7	52	325	0.8	STD	75%	2.6
					325	0.8	MED	87%	3.4
					325	0.8	HIGH	89%	4.2
575-3-60	518	633	5.8	39	325	0.6	STD	73%	2.4
					325	0.6	MED	78%	2.0
					325	0.6	HIGH	77%	2.8

## ELECTRICAL INFORMATION (cont.)

**Table 61 – RGS072, SINGLE STAGE COOLING WITH SINGLE SPEED INDOOR FAN MOTOR, 6 TONS**

V-Ph-Hz	VOLTAGE RANGE		COMP (ea)		OFM (ea)		IFM		
	MIN	MAX	RLA	LRA	WATTS	FLA	TYPE	EFF at Full Load	FLA
208-3-60	187	253	19.6	136	325	1.5	STD	87%	6.9
					325	1.5	MED	89%	8.4
					325	1.5	HIGH	87%	10.6
230-3-60	187	253	19.6	136	325	1.5	STD	87%	6.7
					325	1.5	MED	89%	8.3
					325	1.5	HIGH	87%	10.6
460-3-60	414	506	8.2	66	325	0.8	STD	87%	3.4
					325	0.8	MED	89%	4.2
					325	0.8	HIGH	87%	5.3
575-3-60	518	633	6.6	55	325	0.6	STD	78%	2.0
					325	0.6	MED	77%	2.8
					325	0.6	HIGH	77%	2.8

**Table 62 – RGS091, SINGLE STAGE COOLING WITH SINGLE SPEED INDOOR FAN MOTOR, 7.5 TONS**

V-Ph-Hz	VOLTAGE RANGE		COMP (ea)		OFM (ea)		IFM		
	MIN	MAX	RLA	LRA	WATTS	FLA	TYPE	EFF at Full Load	FLA
208-3-60	187	253	25.0	164	325	1.5	STD	87%	5.2
					325	1.5	MED	89%	8.4
					325	1.5	HIGH	83%	13.6
230-3-60	187	253	25.0	164	325	1.5	STD	87%	4.9
					325	1.5	MED	89%	8.3
					325	1.5	HIGH	83%	12.7
460-3-60	414	506	12.2	100	325	0.8	STD	87%	2.5
					325	0.8	MED	89%	4.2
					325	0.8	HIGH	83%	6.4
575-3-60	518	633	9.0	78	325	0.6	STD	72%	1.6
					325	0.6	MED	77%	2.8
					325	0.6	HIGH	81%	5.6

**Table 63 – RGS090, 2-STAGE COOLING WITH SINGLE SPEED INDOOR FAN MOTOR, 7.5 TONS**

V-Ph-Hz	VOLTAGE RANGE		COMP (Cir 1)		COMP (Cir 2)		OFM (ea)		IFM		
	MIN	MAX	RLA	LRA	RLA	LRA	WATTS	FLA	TYPE	EFF at Full Load	FLA
208-3-60	187	253	13.6	83	13.6	83	325	1.5	STD	87%	5.2
							325	1.5	MED	89%	8.4
							325	1.5	HIGH	83%	13.6
230-3-60	187	253	13.6	83	13.6	83	325	1.5	STD	87%	4.9
							325	1.5	MED	89%	8.3
							325	1.5	HIGH	83%	12.7
460-3-60	414	506	6.1	41	6.1	41	325	0.8	STD	87%	2.5
							325	0.8	MED	89%	4.2
							325	0.8	HIGH	83%	6.4
575-3-60	518	633	4.2	33	4.2	33	325	0.6	STD	72%	1.6
							325	0.6	MED	77%	2.8
							325	0.6	HIGH	81%	5.6

## ELECTRICAL INFORMATION (cont.)

**Table 64 – RGS090, 2-STAGE COOLING WITH 2 SPEED INDOOR FAN MOTOR, 7.5 TONS**

V-Ph-Hz	VOLTAGE RANGE		COMP 1		COMP 2		OFM (ea)		IFM		
	MIN	MAX	RLA	LRA	RLA	LRA	WATTS	FLA	TYPE	EFF at Full Load	FLA
208-3-60	187	253	13.6	83	13.6	83	325	1.5	STD	0.84	5.8
							325	1.5	MED	0.85	8.6
							325	1.5	HIGH	0.84	13.6
230-3-60	187	253	13.6	83	13.6	83	325	1.5	STD	0.84	5.6
							325	1.5	MED	0.85	7.8
							325	1.5	HIGH	0.84	12.7
460-3-60	414	506	6.1	41	6.1	41	325	0.8	STD	0.79	2.9
							325	0.8	MED	0.85	3.8
							325	0.8	HIGH	0.84	6.4
575-3-60	518	633	4.2	33	4.2	33	325	0.6	STD	0.81	2.8
							325	0.6	MED	0.84	4.5
							325	0.6	HIGH	0.83	6.2

**Table 65 – RGS101, SINGLE STAGE COOLING WITH SINGLE SPEED INDOOR FAN MOTOR, 8.5 TONS**

V-Ph-Hz	VOLTAGE RANGE		COMP (ea)		OFM (ea)		IFM		
	MIN	MAX	RLA	LRA	WATTS	FLA	TYPE	EFF at Full Load	FLA
208-3-60	187	253	29.5	195	325	1.5	STD	87%	5.2
					325	1.5	MED	87%	6.9
					325	1.5	HIGH	87%	10.6
230-3-60	187	253	29.5	195	325	1.5	STD	87%	4.9
					325	1.5	MED	87%	6.7
					325	1.5	HIGH	87%	10.6
460-3-60	414	506	14.7	95	325	0.8	STD	87%	2.5
					325	0.8	MED	87%	3.4
					325	0.8	HIGH	87%	5.3
575-3-60	518	633	12.2	80	325	0.6	STD	72%	1.6
					325	0.6	MED	78%	2.0
					325	0.6	HIGH	77%	2.8

**Table 66 – RGS102, 2-STAGE COOLING WITH SINGLE SPEED INDOOR FAN MOTOR, 8.5 TONS**

V-Ph-Hz	VOLTAGE RANGE		COMP (Cir 1)		COMP (Cir 2)		OFM (ea)		IFM		
	MIN	MAX	RLA	LRA	RLA	LRA	WATTS	FLA	TYPE	EFF at Full Load	FLA
208-3-60	187	253	14.5	98	13.7	83	325	1.5	STD	87%	5.2
							325	1.5	MED	87%	6.9
							325	1.5	HIGH	87%	10.6
230-3-60	187	253	14.5	98	13.7	83	325	1.5	STD	87%	4.9
							325	1.5	MED	87%	6.7
							325	1.5	HIGH	87%	10.6
460-3-60	414	506	6.3	55	6.2	41	325	0.8	STD	87%	2.5
							325	0.8	MED	87%	3.4
							325	0.8	HIGH	87%	5.3
575-3-60	518	633	6.0	41	4.8	33	325	0.6	STD	72%	1.6
							325	0.6	MED	78%	2.0
							325	0.6	HIGH	77%	2.8

## ELECTRICAL INFORMATION (cont.)

**Table 67 – RGS102, 2-STAGE COOLING WITH 2 SPEED INDOOR FAN MOTOR, 8.5 TONS**

V-Ph-Hz	VOLTAGE RANGE		COMP 1		COMP 2		OFM (ea)		IFM		
	MIN	MAX	RLA	LRA	RLA	LRA	WATTS	FLA	TYPE	EFF at Full Load	FLA
208-3-60	187	253	14.5	98	13.7	83	325	1.5	STD	0.84	5.8
							325	1.5	MED	0.77	7.1
							325	1.5	HIGH	0.82	10.8
230-3-60	187	253	14.5	98	13.7	83	325	1.5	STD	0.84	5.6
							325	1.5	MED	0.77	6.8
							325	1.5	HIGH	0.82	9.8
460-3-60	414	506	6.3	55	6.2	41	325	0.8	STD	0.79	2.9
							325	0.8	MED	0.77	3.8
							325	0.8	HIGH	0.82	4.9
575-3-60	518	633	6.0	41	4.8	33	325	0.6	STD	0.81	2.8
							325	0.6	MED	0.80	3.5
							325	0.6	HIGH	0.84	4.5

**Table 68 – RGS121, SINGLE STAGE COOLING WITH SINGLE SPEED INDOOR FAN MOTOR, 10 TONS**

V-Ph-Hz	VOLTAGE RANGE		COMP (ea)		OFM (ea)		IFM		
	MIN	MAX	RLA	LRA	WATTS	FLA	TYPE	EFF at Full Load	FLA
208-3-60	187	253	30.1	225	325	1.5	STD	87%	6.9
					325	1.5	MED	87%	10.6
					325	1.5	HIGH	83%	13.6
230-3-60	187	253	30.1	225	325	1.5	STD	87%	6.7
					325	1.5	MED	87%	10.6
					325	1.5	HIGH	83%	12.7
460-3-60	414	506	16.7	114	325	0.8	STD	87%	3.4
					325	0.8	MED	87%	5.3
					325	0.8	HIGH	83%	6.4
575-3-60	518	633	12.2	80	325	0.6	STD	78%	2.0
					325	0.6	MED	77%	2.8
					325	0.6	HIGH	81%	5.6

**Table 69 – RGS120, 2-STAGE COOLING WITH SINGLE SPEED INDOOR FAN MOTOR, 10 TONS**

V-Ph-Hz	VOLTAGE RANGE		COMP (Cir 1)		COMP (Cir 2)		OFM (ea)		IFM		
	MIN	MAX	RLA	LRA	RLA	LRA	WATTS	FLA	TYPE	EFF at Full Load	FLA
208-3-60	187	253	15.6	110	15.9	110	325	1.5	STD	87%	6.9
							325	1.5	MED	87%	10.6
							325	1.5	HIGH	83%	13.6
230-3-60	187	253	15.6	110	15.9	110	325	1.5	STD	87%	6.7
							325	1.5	MED	87%	10.6
							325	1.5	HIGH	83%	12.7
460-3-60	414	506	7.7	52	7.7	52	325	0.8	STD	87%	3.4
							325	0.8	MED	87%	5.3
							325	0.8	HIGH	83%	6.4
575-3-60	518	633	5.8	39	5.7	39	325	0.6	STD	78%	2.0
							325	0.6	MED	77%	2.8
							325	0.6	HIGH	81%	5.6

## ELECTRICAL INFORMATION (cont.)

**Table 70 – RGS120, 2-STAGE COOLING WITH 2 SPEED INDOOR FAN MOTOR, 10 TONS**

V-Ph-Hz	VOLTAGE RANGE		COMP 1		COMP 2		OFM (ea)		IFM		
	MIN	MAX	RLA	LRA	RLA	LRA	WATTS	FLA	TYPE	EFF at Full Load	FLA
208-3-60	187	253	15.6	110	15.9	110	325	1.5	STD	0.77	7.1
							325	1.5	MED	0.82	10.8
							325	1.5	HIGH	0.84	13.6
230-3-60	187	253	15.6	110	15.9	110	325	1.5	STD	0.77	6.8
							325	1.5	MED	0.82	9.8
							325	1.5	HIGH	0.84	12.7
460-3-60	414	506	7.7	52	7.7	52	325	0.8	STD	0.77	3.8
							325	0.8	MED	0.82	4.9
							325	0.8	HIGH	0.84	6.4
575-3-60	518	633	5.8	39	5.7	39	325	0.6	STD	0.80	3.5
							325	0.6	MED	0.84	4.5
							325	0.6	HIGH	0.83	6.2

**Table 71 – RGS150, 2-STAGE COOLING WITH SINGLE SPEED INDOOR FAN MOTOR, 12.5 TONS**

V-Ph-Hz	VOLTAGE RANGE		COMP (Cir 1)		COMP (Cir 2)		OFM (ea)		IFM		
	MIN	MAX	RLA	LRA	RLA	LRA	WATTS	FLA	TYPE	EFF at Full Load	FLA
208-3-60	187	253	19.0	123	22.4	149	1070	6.2	STD	89%	8.4
							1070	6.2	MED	87%	10.6
							1070	6.2	HIGH	83%	13.6
230-3-60	187	253	19.0	123	22.4	149	1070	6.2	STD	89%	8.3
							1070	6.2	MED	87%	10.6
							1070	6.2	HIGH	83%	12.7
460-3-60	414	506	9.7	62	10.6	75	1070	3.1	STD	89%	4.2
							1070	3.1	MED	87%	5.3
							1070	3.1	HIGH	83%	6.4
575-3-60	518	633	7.4	50	7.7	54	1070	2.5	STD	77%	2.8
							1070	2.5	MED	77%	2.8
							1070	2.5	HIGH	81%	5.6

**Table 72 – RGS150, 2-STAGE COOLING WITH 2 SPEED INDOOR FAN MOTOR, 12.5 TONS**

V-Ph-Hz	VOLTAGE RANGE		COMP 1		COMP 2		OFM (ea)		IFM		
	MIN	MAX	RLA	LRA	RLA	LRA	WATTS	FLA	TYPE	EFF at Full Load	FLA
208-3-60	187	253	19.0	123	22.4	149	1070	6.2	STD	0.85	8.6
							1070	6.2	MED	0.82	10.8
							1070	6.2	HIGH	0.84	13.6
230-3-60	187	253	19.0	123	22.4	149	1070	6.2	STD	0.85	7.8
							1070	6.2	MED	0.82	9.8
							1070	6.2	HIGH	0.84	12.7
460-3-60	414	506	9.7	62	10.6	75	1070	3.1	STD	0.85	3.8
							1070	3.1	MED	0.82	4.9
							1070	3.1	HIGH	0.84	6.4
575-3-60	518	633	7.4	50	7.7	54	1070	2.5	STD	0.84	4.5
							1070	2.5	MED	0.84	4.5
							1070	2.5	HIGH	0.83	6.2

## ELECTRICAL INFORMATION (cont.)

**Table 73 – RGS180, 2-STAGE COOLING WITH SINGLE SPEED INDOOR FAN MOTOR, 15 TONS**

V-Ph-Hz	VOLTAGE RANGE		COMP (Cir 1)		COMP (Cir 2)		OFM (ea)		IFM		
	MIN	MAX	RLA	LRA	RLA	LRA	WATTS	FLA	TYPE	EFF at Full Load	FLA
208-3-60	187	253	25.0	164	25.0	164	280	1.5	STD	89%	8.4
							280	1.5	MED	87%	10.6
							280	1.5	HIGH	90%	20.4
230-3-60	187	253	25.0	164	25.0	164	280	1.5	STD	89%	8.3
							280	1.5	MED	87%	10.6
							280	1.5	HIGH	90%	20.4
460-3-60	414	506	12.2	100	12.8	100	280	0.8	STD	89%	4.2
							280	0.8	MED	87%	5.3
							280	0.8	HIGH	90%	10.2
575-3-60	518	633	9.8	78	9.6	78	280	0.6	STD	77%	2.8
							280	0.6	MED	77%	2.8
							280	0.6	HIGH	94%	9.0

**Table 74 – RGS180, 2-STAGE COOLING WITH 2 SPEED INDOOR FAN MOTOR, 15 TONS**

V-Ph-Hz	VOLTAGE RANGE		COMP 1		COMP 2		OFM (ea)		IFM		
	MIN	MAX	RLA	LRA	RLA	LRA	WATTS	FLA	TYPE	EFF at Full Load	FLA
208-3-60	187	253	25.0	164	25.0	164	280	1.5	STD	0.85	8.6
							280	1.5	MED	0.82	10.8
							280	1.5	HIGH	0.90	20.4
230-3-60	187	253	25.0	164	25.0	164	280	1.5	STD	0.85	7.8
							280	1.5	MED	0.82	9.8
							280	1.5	HIGH	0.90	20.4
460-3-60	414	506	12.2	100	12.8	100	280	0.8	STD	0.85	3.8
							280	0.8	MED	0.82	4.9
							280	0.8	HIGH	0.90	10.2
575-3-60	518	633	9.8	78	9.6	78	280	0.6	STD	0.84	4.5
							280	0.6	MED	0.84	4.5
							280	0.6	HIGH	0.94	9

# ELECTRICAL INFORMATION

**Table 75 – Unit Wire/Fuse or HACR Breaker Sizing Data With Single Speed Indoor Fan Motor**

UNIT	NOM. V-Ph-Hz	IFM TYPE	NO C.O. or UNPWR C.O.							
			NO P.E.				w/ P.E. (pwrd fr/ unit)			
			MCA	Max Fuse or HACR Brkr	DISC. SIZE		MCA	Max Fuse or HACR Brkr	DISC. SIZE	
					FLA	LRA			FLA	LRA
RGS036	208/230-1-60	STD	28	40	26	95	30	45	29	97
		MED	28	40	26	95	30	45	29	97
	208/230-3-60	STD	20	30	20	96	22	30	22	98
		MED	20	30	20	96	22	30	22	98
		HIGH	22/22	30/30	22/21	134	24/24	30/30	24/24	136
	460-3-60	STD	11	15	11	49	12	15	12	50
		MED	11	15	11	49	12	15	12	50
		HIGH	12	15	12	68	13	15	13	69
	575-3-60	STD	8	15	8	46	10	15	10	48
		MED	8	15	8	46	10	15	10	48
		HIGH	8	15	7	50	10	15	10	52
	RGS048	208/230-1-60	STD	34	50	32	133	36	50	35
MED			34	50	32	133	36	50	35	135
208/230-3-60		STD	24	30	23	106	26	30	26	108
		MED	24	30	23	106	26	30	26	108
		HIGH	26/26	30/30	25/25	144	28/28	40/40	28/27	146
460-3-60		STD	12	15	11	52	13	15	12	53
		MED	12	15	11	52	13	15	12	53
		HIGH	12	15	12	71	13	15	13	72
575-3-60		STD	9	15	9	42	11	15	11	44
		MED	9	15	9	42	11	15	11	44
		HIGH	9	15	9	46	11	15	11	48
RGS060		208/230-1-60	STD	40	60	37	150	42	60	40
	MED		42	60	40	175	44	60	42	177
	208/230-3-60	STD	27	40	26	133	29	40	28	135
		MED	28/28	40/40	28/27	171	30/30	45/45	30/30	173
		HIGH	30/30	45/40	29/29	186	32/32	45/45	32/31	188
	460-3-60	STD	13	20	13	63	14	20	14	64
		MED	14	20	14	82	15	20	15	83
		HIGH	15	20	15	90	16	20	16	91
	575-3-60	STD	11	15	10	48	13	15	12	50
		MED	10	15	10	52	12	15	12	54
		HIGH	11	15	11	63	13	15	13	65
	RGS072	208/230-3-60	STD	33/32	50/50	32/31	184	35/34	50/50	34/33
MED			34/34	50/50	33/33	199	36/36	50/50	35/35	201
HIGH			36	50	36	213	38	50	38	215
460-3-60		STD	17	25	16	92	18	25	17	93
		MED	18	25	17	100	19	25	18	101
		HIGH	19	25	18	107	20	25	19	108
575-3-60		STD	12	15	12	63	14	20	14	65
		MED	13	20	12	74	15	20	15	76
		HIGH	13	20	12	74	15	20	15	76

**NOTE:** See page 77 for table legend and notes.



# ELECTRICAL INFORMATION (cont.)

**Table 75 – Unit Wire/Fuse or HACR Breaker Sizing Data With Single Speed Indoor Fan Motor**

UNIT	NOM. V-Ph-Hz	IFM TYPE	NO C.O. or UNPWR C.O.							
			NO P.E.				w/ P.E. (pwrd fr/ unit)			
			MCA	Max Fuse or HACR Brkr	DISC. SIZE		MCA	Max Fuse or HACR Brkr	DISC. SIZE	
					FLA	LRA			FLA	LRA
RGS091	208/230-3-60	STD	40/40	60/60	38/38	208	44/43	60/60	43/42	212
		MED	43/43	60/60	42/42	244	47/47	60/60	46/46	248
		HIGH	48/47	60/60	48/47	260	52/51	60/60	52/51	264
	460-3-60	STD	20	30	19	122	22	30	21	124
		MED	22	30	21	140	23	30	23	142
		HIGH	24	30	23	148	26	30	25	150
	575-3-60	STD	15	20	14	89	18	25	18	93
		MED	16	20	15	104	20	25	19	108
		HIGH	19	25	18	118	22	30	23	122
RGS090	208/230-3-60	STD	39/39	50/50	41/40	210	43/43	50/50	45/45	214
		MED	42/42	50/50	44/44	246	46/46	50/50	49/49	250
		HIGH	48/47	60/50	50/49	262	51/51	60/60	55/54	266
	460-3-60	STD	18	20	19	104	20	25	21	106
		MED	20	25	21	122	22	25	23	124
		HIGH	22	25	23	130	24	30	25	132
	575-3-60	STD	13	15	13	77	17	20	17	81
		MED	14	15	14	92	18	20	19	96
		HIGH	17	20	17	106	21	25	22	110
RGS101	208/230-3-60	STD	46/45	60/60	43/43	239	49/49	60/60	48/47	243
		MED	47/47	60/60	45/45	260	51/51	60/60	50/49	264
		HIGH	51	60	50	289	55	80	54	293
	460-3-60	STD	23	30	22	117	25	30	24	119
		MED	24	30	23	127	26	30	25	129
		HIGH	26	30	25	142	28	40	27	144
	575-3-60	STD	19	30	17	91	22	30	22	95
		MED	19	30	18	95	23	30	22	99
		HIGH	20	30	19	106	24	30	23	110
RGS102	208/230-3-60	STD	40/40	50/50	42/42	225	44/44	50/50	46/46	229
		MED	42/42	50/50	44/44	246	46/46	60/50	48/48	250
		HIGH	46	50	48	275	50	60	52	279
	460-3-60	STD	19	20	19	118	20	25	21	120
		MED	20	25	20	128	21	25	22	130
		HIGH	21	25	22	143	23	25	24	145
	575-3-60	STD	16	20	16	85	19	25	20	89
		MED	16	20	16	89	20	25	20	93
		HIGH	17	20	17	100	21	25	21	104

**NOTE:** See page 77 for table legend and notes.

# ELECTRICAL INFORMATION (cont.)

**Table 75 – Unit Wire/Fuse or HACR Breaker Sizing Data With Single Speed Indoor Fan Motor**

UNIT	NOM. V-Ph-Hz	IFM TYPE	NO C.O. or UNPWR C.O.							
			NO P.E.				w/ P.E. (pwrd fr/ unit)			
			MCA	Max Fuse or HACR Brkr	DISC. SIZE		MCA	Max Fuse or HACR Brkr	DISC. SIZE	
					FLA	LRA			FLA	LRA
RGS121	208/230-3-60	STD	48/48	60/60	46/46	290	52/52	60/60	50/50	294
		MED	52	60	50	319	55	80	55	323
		HIGH	55/54	80/80	54/53	321	58/58	80/80	58/57	325
	460-3-60	STD	26	40	25	146	28	40	27	148
		MED	28	40	27	161	30	45	29	163
		HIGH	29	45	28	162	31	45	30	164
	575-3-60	STD	19	30	18	95	23	30	22	99
		MED	20	30	19	106	24	30	23	110
		HIGH	23	30	22	120	26	30	26	124
RGS120	208/230-3-60	STD	46/46	60/60	48/47	285	50/49	60/60	52/52	289
		MED	50	60	52	314	53	60	56	318
		HIGH	53/52	60/60	55/54	316	56/55	60/60	60/59	320
	460-3-60	STD	23	30	23	136	25	30	26	138
		MED	25	30	26	151	26	30	28	153
		HIGH	26	30	27	152	28	30	29	154
	575-3-60	STD	17	20	17	93	20	25	21	97
		MED	17	20	18	104	21	25	22	108
		HIGH	20	25	21	118	24	30	25	122
RGS150	208/230-3-60	STD	62/62	80/80	64/64	376	66/66	80/80	69/69	380
		MED	64	80	67	390	68	80	71	394
		HIGH	67/66	80/80	70/69	392	71/70	80/80	75/74	396
	460-3-60	STD	31	40	32	189	33	40	34	191
		MED	32	40	33	196	34	40	35	198
		HIGH	33	40	34	197	35	40	36	199
	575-3-60	STD	23	30	23	142	27	30	28	146
		MED	23	30	23	142	27	30	28	146
		HIGH	26	30	27	156	29	35	31	160
RGS180	208/230-3-60	STD	70/70	80/80	72/72	412	73/73	80/80	77/77	416
		MED	72	80	75	426	76	100	79	430
		HIGH	82	100	86	432	85	100	91	436
	460-3-60	STD	35	45	36	242	37	45	38	244
		MED	36	45	38	249	38	50	40	251
		HIGH	41	50	43	252	43	50	45	254
	575-3-60	STD	27	30	28	184	31	40	32	188
		MED	27	30	28	184	31	40	32	188
		HIGH	33	40	35	196	37	45	39	200

**NOTE:** See page 77 for table legend and notes.

# ELECTRICAL INFORMATION

**Table 76 – Unit Wire/Fuse or HACR Breaker Sizing Data for 2–stage Cooling With 2–Speed Fan Motor**

UNIT	NOM. V–Ph–Hz	IFM TYPE	NO C.O. or UNPWR C.O.							
			NO P.E.				w/ P.E. (pwrd fr/ unit)			
			MCA	Max Fuse or HACR Brkr	DISC. SIZE		MCA	Max Fuse or HACR Brkr	DISC. SIZE	
					FLA	LRA			FLA	LRA
RGS090	208/230–3–60	STD	40/40	50/50	41/41	197	44/43	50/50	46/46	201
		MED	43/42	50/50	45/44	227	46/46	50/50	49/48	231
		HIGH	48/47	60/50	50/49	262	51/51	60/60	55/54	266
	460–3–60	STD	19	20	19	97	20	25	21	99
		MED	20	25	20	113	21	25	22	115
		HIGH	22	25	23	130	24	30	25	132
	575–3–60	STD	14	15	14	79	18	20	19	83
		MED	16	20	16	92	19	25	21	96
		HIGH	18	20	18	106	22	25	23	110
RGS102	208/230–3–60	STD	41/41	50/50	43/42	212	45/45	50/50	47/47	216
		MED	42/42	50/50	44/44	216	46/46	60/50	48/48	220
		HIGH	46/45	60/50	48/47	266	50/49	60/60	53/52	270
	460–3–60	STD	19	25	20	111	21	25	22	113
		MED	20	25	21	114	22	25	23	116
		HIGH	21	25	22	139	23	25	24	141
	575–3–60	STD	17	20	17	87	21	25	21	91
		MED	17	20	18	91	21	25	22	95
		HIGH	18	20	19	100	22	25	23	104
RGS120	208/230–3–60	STD	46/46	60/60	48/47	255	50/50	60/60	52/52	259
		MED	50/49	60/60	52/51	305	54/53	60/60	56/55	309
		HIGH	53/52	60/60	55/54	316	56/55	60/60	60/59	320
	460–3–60	STD	23	30	24	122	25	30	26	124
		MED	24	30	25	147	26	30	27	149
		HIGH	26	30	27	152	28	30	29	154
	575–3–60	STD	18	20	19	95	22	25	23	99
		MED	19	25	20	104	23	25	24	108
		HIGH	21	25	22	118	25	30	26	122
RGS150	208/230–3–60	STD	62/61	80/80	65/64	357	66/65	80/80	69/68	361
		MED	64/63	80/80	67/66	381	68/67	80/80	72/70	385
		HIGH	67/66	80/80	70/69	392	71/70	80/80	75/74	396
	460–3–60	STD	30	40	31	180	32	40	33	182
		MED	31	40	33	192	33	40	35	194
		HIGH	33	40	34	197	35	40	36	199
	575–3–60	STD	24	30	25	142	28	30	30	146
		MED	24	30	25	142	28	30	30	146
		HIGH	26	30	27	156	30	35	32	160
RGS180	208/230–3–60	STD	70/69	80/80	73/72	393	74/73	80/80	77/76	397
		MED	72/71	80/80	75/74	417	76/75	100/90	79/78	421
		HIGH	82	100	86	432	85	100	91	436
	460–3–60	STD	35	45	36	233	37	45	38	235
		MED	36	45	37	245	38	50	39	247
		HIGH	41	50	43	252	43	50	45	254
	575–3–60	STD	29	35	30	184	32	40	34	188
		MED	29	35	30	184	32	40	34	188
		HIGH	33	40	35	196	37	45	39	200

**NOTE:** See page 77 for table legend and notes.

## Legend and Notes for Electrical Information

### LEGEND:

BRKR	–	Circuit breaker
CO	–	Convenience outlet
DISC	–	Disconnect
FLA	–	Full load amps
IFM	–	Indoor fan motor
LRA	–	Locked rotor amps
MCA	–	Minimum circuit amps
PE	–	Power exhaust
UNPWR CO	–	Unpowered convenient outlet

### NOTES:

1. In compliance with NEC requirements for multimotor and combination load equipment (refer to NEC Articles 430 and 440), the overcurrent protective device for the unit shall be fuse or HACR breaker. Canadian units may be fuse or circuit breaker.

#### 1. Unbalanced 3-Phase Supply Voltage

Never operate a motor where a phase imbalance in supply voltage is greater than 2%. Use the following formula to determine the percentage of voltage imbalance.

$$\% \text{ Voltage Imbalance} = 100 \times \frac{\text{max voltage deviation from average voltage}}{\text{average voltage}}$$

Example: Supply voltage is 230-3-60



AB = 224 v  
BC = 231 v  
AC = 226 v

$$\begin{aligned} \text{Average Voltage} &= \frac{(224 + 231 + 226)}{3} = \frac{681}{3} \\ &= 227 \end{aligned}$$

Determine maximum deviation from average voltage.

(AB) 227 – 224 = 3 v

(BC) 231 – 227 = 4 v

(AC) 227 – 226 = 1 v

Maximum deviation is 4 v.

Determine percent of voltage imbalance.

$$\begin{aligned} \% \text{ Voltage Imbalance} &= 100 \times \frac{4}{227} \\ &= 1.76\% \end{aligned}$$

This amount of phase imbalance is satisfactory as it is below the maximum allowable 2%.

**IMPORTANT:** If the supply voltage phase imbalance is more than 2%, contact your local electric utility company immediately.

## SEQUENCE OF OPERATION

### General

The sequence below describes the sequence of operation for an electro-mechanical unit with and without a factory installed Economizer IV or X. For information regarding a direct digital controller, see the start-up, operations, and troubleshooting manual for the applicable controller.

### Units with no Economizer

#### Cooling —

When the thermostat calls for cooling, terminals G and Y1 are energized. As a result, the indoor fan contactor (IFC) and the compressor contactor (C1) are energized, causing the indoor fan motor (IFM), compressor #1, and outdoor fan to start. If the unit has 2 stages of cooling, the thermostat will additionally energize Y2. The Y2 signal will energize compressor contactor #2 (C2), causing compressor #2 to start. Regardless of the number of stages, the outdoor fan motor runs continuously while unit is cooling. When 2-speed motor with VFD system is utilized, indoor fan motor runs at design CFM (full speed) during the heating operation.

**Cooling (2-speed indoor fan motor)** —Per ASHRAE 90.1 standard section 6.4.3.10.b, during the first stage of cooling operation the VFD will adjust the fan motor to provide 2/3rd of the total cfm established for the unit. When a call for the second stage of cooling is required, the VFD will allow the total cfm for the unit established (100%).

#### Heating

**NOTE:** RGS units have either 1 or 2 stages of gas heat. When 2-speed indoor fan motor system is utilized, indoor fan motor runs at design cfm (full speed) during the heating operation.

When the thermostat calls for heating, power is sent to W on the Integrated Gas Controller (IGC) board. An LED (light-emitting diode) on the IGC board turns on and remains on during normal operation. A check is made to ensure that the rollout switch and limit switch are closed and the induced-draft motor is running. If the check was successful, the induced-draft motor is energized, and when its speed is satisfactory, as proven by the “hall effect” sensor, the ignition activation period begins. The burners will ignite within 5 seconds. If the burners do not light, there is a 22-second delay before another 5-second attempt. This sequence is repeated for 15 minutes or until the burners light. If, after the 15 minutes, the burners still have not lit, heating is

locked out. To reset the control, break 24-v power to the thermostat.

When ignition occurs, the IGC board will continue to monitor the condition of the rollout switch, the limit switches, the “hall effect” sensor, as well as the flame sensor. 45 seconds after ignition occurs, assuming the unit is controlled through a room thermostat set for fan auto, the indoor-fan motor will energize (and the outdoor-air dampers will open to their minimum position). If, for some reason, the over-temperature limit opens prior to the start of the indoor fan blower, the unit will shorten the 45-second delay to 5 seconds less than the time from initiation of heat to when the limit tripped. Gas will not be interrupted to the burners and heating will continue. Once the fan-on delay has been modified, it will not change back to 45 seconds until power is reset to the control.

On units with 2 stages of heat, when additional heat is required, W2 closes and initiates power to the second stage of the main gas valve. When the thermostat is satisfied, W1 and W2 open and the gas valve closes, interrupting the flow of gas to the main burners.

If the call for W1 lasted less than 1 minute, the heating cycle will not terminate until 1 minute after W1 became active. If the unit is controlled through a room thermostat set for fan auto, the indoor-fan motor will continue to operate for an additional 45 seconds then stop. If the over-temperature limit opens after the indoor motor is stopped, but within 10 minutes of W1 becoming inactive, on the next cycle the time will be extended by 15 seconds. The maximum delay is 3 minutes. Once modified, the fan off delay will not change back to 45 seconds unless power is reset to the control. A LED indicator is provided on the IGC to monitor operation.

### Units with an Economizer

#### Cooling —

When free cooling is not available, the compressors will be controlled by the zone thermostat. When free cooling is available, the outdoor-air damper is modulated by the economizer control to provide a 50°F (10°C) to 55°F (13°C) mixed-air temperature into the zone. As the mixed air temperature fluctuates above 55°F (13°C) or below 50°F (10°C) dampers will be modulated (open or close) to bring the mixed-air temperature back within control. If mechanical cooling is utilized with free cooling, the outdoor-air damper will maintain its current position at the time the compressor is started. If the

increase in cooling capacity causes the mixed-air temperature to drop below 45°F (7°C), then the outdoor-air damper position will be decreased to the minimum position. If the mixed-air temperature continues to fall, the outdoor-air damper will close. Control returns to normal once the mixed-air temperature rises above 48°F (9°C). The power exhaust fans will be energized and de-energized, if installed, as the outdoor-air damper opens and closes.

If field-installed accessory CO2 sensors are connected to the economizer control, a demand controlled ventilation strategy will begin to operate. As the CO2 level in the zone increases above the CO2 set point, the minimum position of the damper will be increased proportionally. As the CO2 level decreases because of the increase in fresh air, the outdoor-air damper will be proportionally closed. For economizer operation, there must be a thermostat call for the fan (G). If the unit is occupied and the fan is on, the damper will operate at minimum position. Otherwise, the damper will be closed.

When the economizer control is in the occupied mode and a call for cooling exists (Y1 on the thermostat), the control will first check for indoor fan operation. If the fan is not on, then cooling will not be activated. If the fan is on, then the control will open the economizer damper to the minimum position.

On the initial power to the economizer control, it will take the damper up to 2 1/2 minutes before it begins to position itself. After the initial power-up, further changes in damper position can take up to 30 seconds to initiate. Damper movement from full closed to full open (or vice versa) will take between 1 1/2 and 2 1/2 minutes. If free cooling can be used as determined from the appropriate changeover command (switch, dry bulb, enthalpy curve, differential dry bulb, or differential enthalpy), then the control will modulate the dampers open to maintain the mixed-air temperature set point at 50°F (10°C) to 55°F (13°C). If there is a further demand for cooling (cooling second stage – Y2 is energized), then the control will bring on compressor stage 1 to maintain the mixed-air temperature set point. The economizer damper will be open at maximum position. economizer operation is limited to a single compressor.

**2-Speed Note:** When operating in ventilation mode only, the indoor fan motor will automatically adjust to 2/3rd of the total cfm established.

### Heating

The sequence of operation for the heating is the same as an unit with no economizer. The only difference is how the economizer acts. The economizer will stay at the Economizer Minimum Position while the evaporator fan is operating. The outdoor-air damper is closed when the indoor fan is not operating.

### Optional Hot Gas Reheat Dehumidification System

Units with the factory equipped Hot Gas Reheat option are capable of providing multiple modes of improved dehumidification as a variation of the normal cooling cycle. The Hot Gas Reheat option includes additional valves in the liquid line and discharge line of each refrigerant circuit, a small reheat condenser coil downstream of the evaporator, and Motormaster variable-speed control of some or all outdoor fans. Operation of the revised refrigerant circuit for each mode is described below.

The Hot Gas Reheat system provides three sub-modes of operation: Cool, Reheat1, and Reheat2.

**Cool mode** – provides a normal ratio of Sensible and Latent Cooling effect from the evaporator coil.

**Reheat1** – provides increased Latent Cooling while slightly reducing the Sensible Cooling effect.

**Reheat2** – provides normal Latent Cooling but with null or minimum Sensible Cooling effect delivered to the space.

The Reheat1 and Reheat2 modes are available when the unit is not in a Heating mode and when the Low Ambient Lockout switch is closed.

The following diagrams depict piping for Single Stage cooling units.

SEQUENCE OF OPERATION (CONT.)

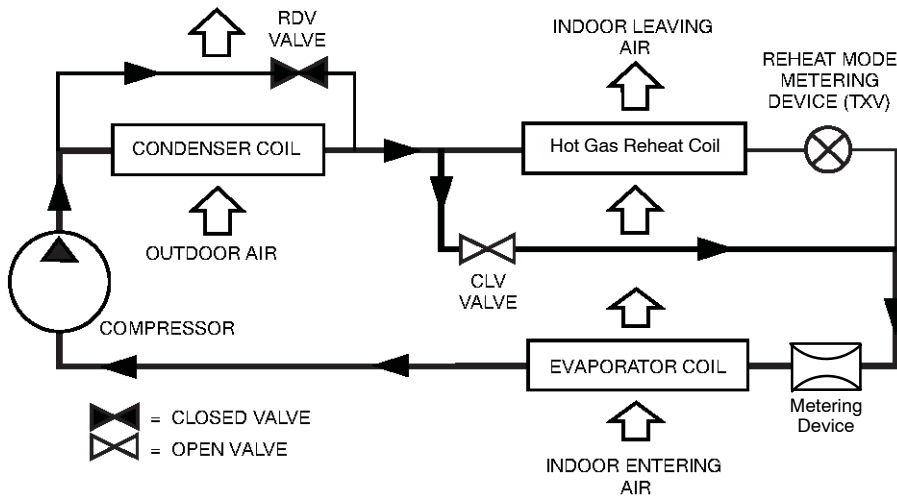

Normal Cooling Mode - Hot Gas Reheat with Single Stage Cooling

C12702

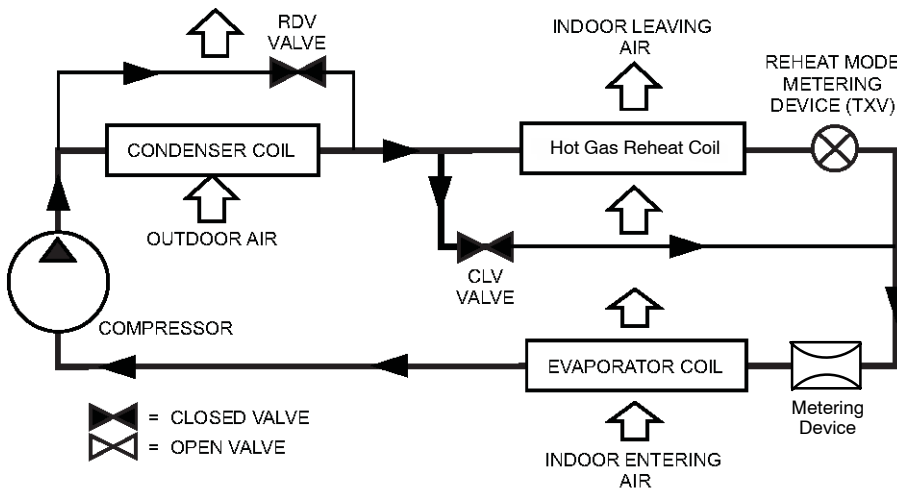

Subcooling Mode (Reheat 1) - Hot Gas Reheat System with Single Stage Cooling

C12703

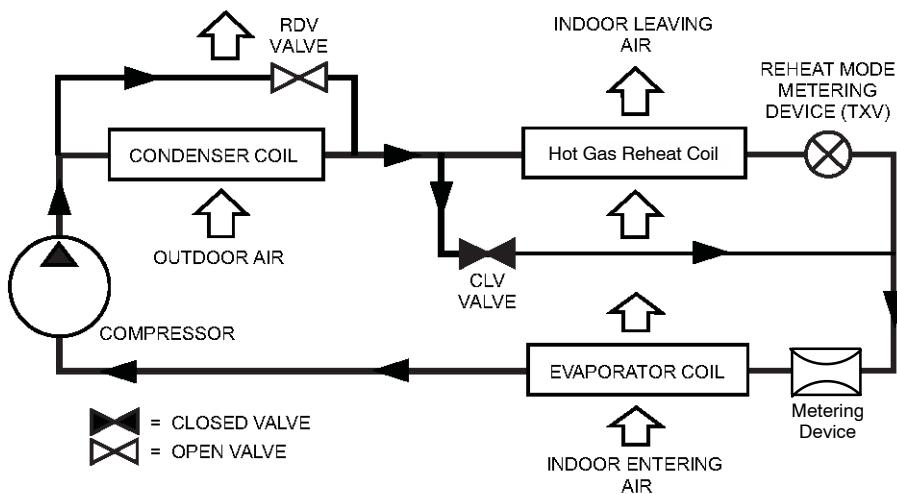

Hot Gas Reheat Mode (Reheat2) - Hot Gas Reheat with Single Stage Cooling

C12704

## Appendix A – Altitude Compensation Tables

NATURAL GAS – SMALL CHASSIS / LOW NOx							
ELEVATION		NOMINAL HEAT INPUT					
		60k BTUH		90k BTUH		120k BTUH	
Feet	Meters	Orifice Size	Input (btu/hr)	Orifice Size	Input (btu/hr)	Orifice Size	Input (btu/hr)
0 – 2000	0 – 610	38 <sup>2</sup>	60,000	38 <sup>2</sup>	90,000	32 <sup>1</sup>	120,000
2000	610	39 <sup>2</sup>	55,200	39 <sup>2</sup>	82,800	33 <sup>1</sup>	110,400
3000	914	†40	52,800	†40	79,200	33 <sup>1</sup>	105,600
4000	1219	†41	50,400	†41	75,600	35 <sup>1</sup>	100,800
5000	1524	†41	48,000	†41	72,000	35 <sup>1</sup>	96,000
6000	1829	†42	45,600	†42	68,400	36 <sup>1</sup>	91,200
7000	2134	†42	43,200	†42	64,800	36 <sup>1</sup>	86,400
8000	2438	†43	40,800	†43	61,200	37 <sup>2</sup>	81,600
9000	2743	†43	38,400	†43	57,600	38 <sup>2</sup>	76,800
10000	3048	44 <sup>2</sup>	36,000	44 <sup>2</sup>	54,000	†40	72,000
11000	3353	44 <sup>2</sup>	33,600	44 <sup>2</sup>	50,400	†41	67,200
12000	3658	45 <sup>2</sup>	31,200	45 <sup>2</sup>	46,800	†42	62,400
13000	3962	47 <sup>3</sup>	28,800	47 <sup>3</sup>	43,200	†43	57,600
14000	4267	48 <sup>3</sup>	26,400	48 <sup>3</sup>	39,600	†43	52,800

NATURAL GAS – SMALL CHASSIS							
ELEVATION		NOMINAL HEAT INPUT					
		72k BTUH		115k BTUH		150k BTUH	
Feet	Meters	Orifice Size	Input (btu/hr)	Orifice Size	Input (btu/hr)	Orifice Size	Input (btu/hr)
0 – 2000	0 – 610	33 <sup>1</sup>	72,000	33 <sup>1</sup>	115,000	†30	150,000
2000	610	35 <sup>1</sup>	66,240	35 <sup>1</sup>	105,800	†30	138,000
3000	914	35 <sup>1</sup>	63,360	35 <sup>1</sup>	101,200	31 <sup>1</sup>	132,000
4000	1219	36 <sup>1</sup>	60,480	36 <sup>1</sup>	96,600	31 <sup>1</sup>	126,000
5000	1524	36 <sup>1</sup>	57,600	36 <sup>1</sup>	92,000	31 <sup>1</sup>	120,000
6000	1829	37 <sup>2</sup>	54,720	37 <sup>2</sup>	87,400	31 <sup>1</sup>	114,000
7000	2134	38 <sup>2</sup>	51,840	38 <sup>2</sup>	82,800	32 <sup>1</sup>	108,000
8000	2438	39 <sup>2</sup>	48,960	39 <sup>2</sup>	78,200	33 <sup>1</sup>	102,000
9000	2743	†40	46,080	†40	73,600	33 <sup>1</sup>	96,000
10000	3048	†41	43,200	†41	69,000	35 <sup>1</sup>	90,000
11000	3353	†42	40,320	†42	64,400	36 <sup>1</sup>	84,000
12000	3658	†43	37,440	†43	59,800	37 <sup>2</sup>	78,000
13000	3962	†43	34,560	†43	55,200	38 <sup>2</sup>	72,000
14000	4267	44 <sup>2</sup>	31,680	44 <sup>2</sup>	50,600	†40	66,000

PROPANE GAS – SMALL CHASSIS							
ELEVATION		NOMINAL HEAT INPUT					
		72k BTUH		115k BTUH		150k BTUH	
Feet	Meters	Orifice Size	Input (btu/hr)	Orifice Size	Input (btu/hr)	Orifice Size	Input (btu/hr)
0 – 2000	0 – 610	51 <sup>4</sup>	72,000	50 <sup>3</sup>	115,000	46 <sup>3</sup>	150,000
2000	610	51 <sup>4</sup>	66,240	51 <sup>4</sup>	105,800	47 <sup>3</sup>	138,000
3000	914	52 <sup>4</sup>	63,360	51 <sup>4</sup>	101,200	47 <sup>3</sup>	132,000
4000	1219	52 <sup>4</sup>	60,480	51 <sup>4</sup>	96,600	48 <sup>3</sup>	126,000
5000	1524	52 <sup>4</sup>	57,600	51 <sup>4</sup>	92,000	48 <sup>3</sup>	120,000
6000	1829	52 <sup>4</sup>	54,720	52 <sup>4</sup>	87,400	48 <sup>3</sup>	114,000
7000	2134	53 <sup>4</sup>	51,840	52 <sup>4</sup>	82,800	49 <sup>3</sup>	108,000
8000	2438	53 <sup>4</sup>	48,960	52 <sup>4</sup>	78,200	49 <sup>3</sup>	102,000
9000	2743	53 <sup>4</sup>	46,080	53 <sup>4</sup>	73,600	50 <sup>3</sup>	96,000
10000	3048	54 <sup>4</sup>	43,200	53 <sup>4</sup>	69,000	50 <sup>3</sup>	90,000
11000	3353	54 <sup>4</sup>	40,320	53 <sup>4</sup>	64,400	51 <sup>4</sup>	84,000
12000	3658	54 <sup>4</sup>	37,440	54 <sup>4</sup>	59,800	51 <sup>4</sup>	78,000
13000	3962	55 <sup>4</sup>	34,560	54 <sup>4</sup>	55,200	52 <sup>4</sup>	72,000
14000	4267	†56	31,680	55 <sup>4</sup>	50,600	53 <sup>4</sup>	66,000

\* As the height above sea level increases, there is less oxygen per cubic ft. of air. Therefore, heat input rate should be reduced at higher altitudes.

† Not included in kit. May be purchased separately through dealer.

ORIFICE	ACC. KIT PN
XX <sup>1</sup>	CRLPELEV001A00
XX <sup>2</sup>	CRLPELEV002A00
XX <sup>3</sup>	CRLPELEV003A00
XX <sup>4</sup>	CRLPELEV004A00

# Appendix A – Altitude Compensation Tables (Cont.)

## NATURAL GAS – LARGE CHASSIS

ELEVATION		NOMINAL HEAT INPUT											
		72k BTUH		125k BTUH		150k BTUH		180k BTUH		224k BTUH		250k BTUH	
FT	M	Orifice Size	Input (btu/hr)	Orifice Size	Input (btu/hr)	Orifice Size	Input (btu/hr)	Orifice Size	Input (btu/hr)	Orifice Size	Input (btu/hr)	Orifice Size	Input (btu/hr)
0 – 2000	0 – 610	33 <sup>1</sup>	72,000	31 <sup>1</sup>	125,000	32 <sup>1</sup>	150,000	31 <sup>1</sup>	180,000	31 <sup>1</sup>	224,000	†30	250,000
2000	610	35 <sup>1</sup>	66,240	32 <sup>1</sup>	115,000	33 <sup>1</sup>	138,000	32 <sup>1</sup>	165,600	32 <sup>1</sup>	206,080	†30	230,000
3000	914	35 <sup>1</sup>	63,360	32 <sup>1</sup>	110,000	35 <sup>1</sup>	132,000	32 <sup>1</sup>	158,400	32 <sup>1</sup>	197,120	31 <sup>1</sup>	220,000
4000	1219	36 <sup>1</sup>	60,480	33 <sup>1</sup>	105,000	35 <sup>1</sup>	126,000	33 <sup>1</sup>	151,200	33 <sup>1</sup>	188,160	31 <sup>1</sup>	210,000
5000	1524	36 <sup>1</sup>	57,600	33 <sup>1</sup>	100,000	35 <sup>1</sup>	120,000	33 <sup>1</sup>	144,000	33 <sup>1</sup>	179,200	31 <sup>1</sup>	200,000
6000	1829	37 <sup>2</sup>	54,720	35 <sup>1</sup>	95,000	36 <sup>1</sup>	114,000	33 <sup>1</sup>	136,800	33 <sup>1</sup>	170,240	31 <sup>1</sup>	190,000
7000	2134	38 <sup>2</sup>	51,840	35 <sup>1</sup>	90,000	36 <sup>1</sup>	108,000	35 <sup>1</sup>	129,600	35 <sup>1</sup>	161,280	32 <sup>1</sup>	180,000
8000	2438	38 <sup>2</sup>	48,960	36 <sup>1</sup>	85,000	36 <sup>1</sup>	102,000	36 <sup>1</sup>	122,400	36 <sup>1</sup>	152,320	33 <sup>1</sup>	170,000
9000	2743	†40	46,080	37 <sup>2</sup>	80,000	37 <sup>2</sup>	96,000	37 <sup>2</sup>	115,200	37 <sup>2</sup>	143,360	33 <sup>1</sup>	160,000
10000	3048	†41	43,200	38 <sup>2</sup>	75,000	38 <sup>2</sup>	90,000	38 <sup>2</sup>	108,000	38 <sup>2</sup>	134,400	35 <sup>1</sup>	150,000
11000	3353	†42	40,320	39 <sup>2</sup>	70,000	†40	84,000	39 <sup>2</sup>	100,800	39 <sup>2</sup>	125,440	36 <sup>1</sup>	140,000
12000	3658	†42	37,440	†41	65,000	†40	78,000	†41	93,600	†41	116,480	37 <sup>2</sup>	130,000
13000	3962	†43	34,560	†42	60,000	†41	72,000	†42	86,400	†42	107,520	38 <sup>2</sup>	120,000
14000	4267	†43	31,680	†43	55,000	†41	66,000	†43	79,200	†43	98,560	†40	110,000

## PROPANE GAS – LARGE CHASSIS

ELEVATION		NOMINAL HEAT INPUT											
		72k BTUH		125k BTUH		150k BTUH		180k BTUH		224k BTUH		250k BTUH	
FT	M	Orifice Size	Input (btu/hr)	Orifice Size	Input (btu/hr)	Orifice Size	Input (btu/hr)	Orifice Size	Input (btu/hr)	Orifice Size	Input (btu/hr)	Orifice Size	Input (btu/hr)
0 – 2000	0 – 610	51 <sup>4</sup>	72,000	49 <sup>3</sup>	125,000	50 <sup>3</sup>	150,000	48 <sup>3</sup>	180,000	48 <sup>3</sup>	224,000	46 <sup>3</sup>	250,000
2000	610	51 <sup>4</sup>	66,240	50 <sup>3</sup>	115,000	51 <sup>4</sup>	138,000	49 <sup>3</sup>	165,600	49 <sup>3</sup>	206,080	47 <sup>3</sup>	230,000
3000	914	52 <sup>4</sup>	63,360	50 <sup>3</sup>	110,000	51 <sup>4</sup>	132,000	49 <sup>3</sup>	158,400	49 <sup>3</sup>	197,120	47 <sup>3</sup>	220,000
4000	1219	52 <sup>4</sup>	60,480	50 <sup>3</sup>	105,000	51 <sup>4</sup>	126,000	49 <sup>3</sup>	151,200	49 <sup>3</sup>	188,160	48 <sup>3</sup>	210,000
5000	1524	52 <sup>4</sup>	57,600	51 <sup>4</sup>	100,000	51 <sup>4</sup>	120,000	50 <sup>3</sup>	144,000	50 <sup>3</sup>	179,200	48 <sup>3</sup>	200,000
6000	1829	52 <sup>4</sup>	54,720	51 <sup>4</sup>	95,000	52 <sup>4</sup>	114,000	50 <sup>3</sup>	136,800	50 <sup>3</sup>	170,240	48 <sup>3</sup>	190,000
7000	2134	53 <sup>4</sup>	51,840	51 <sup>4</sup>	90,000	52 <sup>4</sup>	108,000	50 <sup>3</sup>	129,600	50 <sup>3</sup>	161,280	49 <sup>3</sup>	180,000
8000	2438	53 <sup>4</sup>	48,960	52 <sup>4</sup>	85,000	52 <sup>4</sup>	102,000	51 <sup>4</sup>	122,400	51 <sup>4</sup>	152,320	49 <sup>3</sup>	170,000
9000	2743	53 <sup>4</sup>	46,080	52 <sup>4</sup>	80,000	53 <sup>4</sup>	96,000	51 <sup>4</sup>	115,200	51 <sup>4</sup>	143,360	50 <sup>3</sup>	160,000
10000	3048	54 <sup>4</sup>	43,200	52 <sup>4</sup>	75,000	53 <sup>4</sup>	90,000	52 <sup>4</sup>	108,000	52 <sup>4</sup>	134,400	50 <sup>3</sup>	150,000
11000	3353	54 <sup>4</sup>	40,320	53 <sup>4</sup>	70,000	53 <sup>4</sup>	84,000	52 <sup>4</sup>	100,800	52 <sup>4</sup>	125,440	51 <sup>4</sup>	140,000
12000	3658	54 <sup>4</sup>	37,440	53 <sup>4</sup>	65,000	53 <sup>4</sup>	78,000	53 <sup>4</sup>	93,600	53 <sup>4</sup>	116,480	51 <sup>4</sup>	130,000
13000	3962	55 <sup>4</sup>	34,560	54 <sup>4</sup>	60,000	53 <sup>4</sup>	72,000	53 <sup>4</sup>	86,400	53 <sup>4</sup>	107,520	52 <sup>4</sup>	120,000
14000	4267	55 <sup>4</sup>	31,680	54 <sup>4</sup>	55,000	55 <sup>4</sup>	66,000	54 <sup>4</sup>	79,200	54 <sup>4</sup>	98,560	53 <sup>4</sup>	110,000

\* As the height above sea level increases, there is less oxygen per cubic ft. of air. Therefore, heat input rate should be reduced at higher altitudes.

† Not included in kit. May be purchased separately through dealer.

ORIFICE	ACC. KIT PN
XX <sup>1</sup>	CRLPELEV001A00
XX <sup>2</sup>	CRLPELEV002A00
XX <sup>3</sup>	CRLPELEV003A00
XX <sup>4</sup>	CRLPELEV004A00



# GUIDE SPECIFICATIONS – RGS036–180

Note about this specification:

## GAS HEAT PACKAGED ROOFTOP

### HVAC Guide Specifications

Size Range: 3 to 15 Nominal Tons



#### Section    Description

#### **23 06 80    Schedules for Decentralized HVAC Equipment**

##### **23 06 80.13    Decentralized Unitary HVAC Equipment Schedule**

23 06 80.13.A.    Rooftop unit schedule

1. Schedule is per the project specification requirements.

#### **23 07 16    HVAC Equipment Insulation**

##### **23 07 16.13    Decentralized, Rooftop Units:**

23 07 16.13.A.    Evaporator fan compartment:

1. Interior cabinet surfaces shall be insulated with a minimum 1/2-in. thick, minimum 1 1/2 lb density, flexible fiberglass insulation bonded with a phenolic binder, neoprene coated on the air side.
2. Insulation and adhesive shall meet NFPA 90A requirements for flame spread and smoke generation.

23 07 16.13.B.    Gas heat compartment:

1. Aluminum foil-faced fiberglass insulation shall be used.
2. Insulation and adhesive shall meet NFPA 90A requirements for flame spread and smoke generation.

#### **23 09 13    Instrumentation and Control Devices for HVAC**

##### **23 09 13.23    Sensors and Transmitters**

23 09 13.23.A,    Thermostats

1. Thermostat must
  - a. energize both "W" and "G" when calling for heat.
  - b. have capability to energize 2 different stages of cooling, and 2 different stages of heating.
  - c. must include capability for occupancy scheduling.

#### **23 09 33    Electric and Electronic Control System for HVAC**

##### **23 09 33.13    Decentralized, Rooftop Units:**

23 09 33.13.A.    General:

1. Shall be complete with self-contained low-voltage control circuit protected by a resettable circuit breaker on the 24-v transformer side. Transformer shall have 75VA capability.
2. Shall utilize color-coded wiring.
3. Unit shall include self-contained low-voltage control circuit protected by a fuse on the 24-v transformer side with a resettable circuit breaker.
4. The heat exchanger shall be controlled by an integrated gas controller (IGC) microprocessor. See heat exchanger section of this specification.
5. Unit shall include a minimum of one 8-pin screw terminal connection board for connection of control wiring.

23 09 33.23.B,    Safeties:

1. Compressor over-temperature, over current.
2. Low-pressure switch.
  - a. Units with 2 compressors shall have different sized connectors for the circuit 1 and circuit 2 low and high pressure switches. They shall physically prevent the cross-wiring of the safety switches between circuits 1 and 2.
  - b. Low pressure switch shall use different color wire than the high pressure switch. The purpose is to assist the installer and service person to correctly wire and or troubleshoot the rooftop unit.
3. High-pressure switch.
  - a. Units with 2 compressors shall have different sized connectors for the circuit 1 and circuit 2 low and high pressure switches. They shall physically prevent the cross-wiring of the safety switches between circuits 1 and 2.
  - b. High pressure switch shall use different color wire than the low pressure switch. The purpose is to assist the installer and service person to correctly wire and or troubleshoot the rooftop unit.
4. Automatic reset, motor thermal overload protector.

5. Heating section shall be provided with the following minimum protections:

- a. High-temperature limit switches.
- b. Induced draft motor speed sensor.
- c. Flame rollout switch.
- d. Flame proving controls.

**23 09 93 Sequence of Operations for HVAC Controls**

**23 09 93.13 Decentralized, Rooftop Units:**

23 09 93.13 INSERT SEQUENCE OF OPERATION

**23 40 13 Panel Air Filters**

**23 40 13.13 Decentralized, Rooftop Units:**

23 40 13.13.A. Standard filter section shall

1. Shall consist of factory-installed, low velocity, throwaway 2-in. thick fiberglass filters of commercially available sizes.
2. Unit shall use only one filter size. Multiple sizes are not acceptable.
3. Filters shall be accessible through an access panel with "no-tool" removal as described in the unit cabinet section of this specification (23 81 19.13.H).

**23 81 19 Self-Contained Air Conditioners**

**23 81 19.13 Small-Capacity Self-Contained Air Conditioners (RGS036-180)**

23 81 19.13.A. General

1. Outdoor, rooftop mounted, electrically controlled, heating and cooling unit utilizing a(n) hermetic scroll compressor(s) for cooling duty and gas combustion for heating duty.
2. Factory assembled, single-piece heating and cooling rooftop unit. Contained within the unit enclosure shall be all factory wiring, piping, controls, and special features required prior to field start-up.
3. Unit shall use R-410A refrigerant.
4. Unit shall be installed in accordance with the manufacturer's instructions.
5. Unit must be selected and installed in compliance with local, state, and federal codes.

23 81 19.13.B. Quality Assurance

1. Unit meets ASHRAE 90.1 minimum efficiency requirements.
2. Unit shall be rated in accordance with AHRI Standards 210/240 and 340/360.
3. Unit shall be designed to conform to ASHRAE 15, 2001.
4. Unit shall be UL-tested and certified in accordance with ANSI Z21.47 Standards and UL-listed and certified under Canadian standards as a total package for safety requirements.
5. Insulation and adhesive shall meet NFPA 90A requirements for flame spread and smoke generation.
6. Unit casing shall be capable of withstanding 500-hour salt spray exposure per ASTM B117 (scribed specimen).
7. Unit shall be designed in accordance with ISO 9001, and shall be manufactured in a facility registered by ISO 9001.
8. Roof curb shall be designed to conform to NRCA Standards.
9. Unit shall be subjected to a completely automated run test on the assembly line. The data for each unit will be stored at the factory, and must be available upon request.
10. Unit shall be designed in accordance with UL Standard 1995, including tested to withstand rain.
11. Unit shall be constructed to prevent intrusion of snow and tested to prevent snow intrusion into the control box up to 40 mph.
12. Unit shake tested to assurance level 1, ASTM D4169 to ensure shipping reliability.
13. High Efficient Motors listed shall meet Section 313 of the Energy Independence and Security Act or 2007 (EISA 2007)

23 81 19.13.C. Delivery, Storage, and Handling

1. Unit shall be stored and handled per manufacturer's recommendations.
2. Lifted by crane requires either shipping top panel or spreader bars.
3. Unit shall only be stored or positioned in the upright position.

23 81 19.13.E. Project Conditions

1. As specified in the contract.

23 81 19.13.F. Operating Characteristics

1. Unit shall be capable of starting and running at 115°F (46°C) ambient outdoor temperature, meeting maximum load criteria of AHRI Standard 210/240 or 340/360 at ± 10% voltage.
2. Compressor with standard controls shall be capable of operation down to 40°F (4°C), ambient outdoor temperatures. Accessory winter start kit is necessary if mechanically cooling at ambient temperatures below 40°F (4°C) to 20°F (-7°C). Below 20°F (-7°C) an accessory Motormaster low ambient control is required and the outdoor fan motor needs to be changed to a ball-bearing speed control motor design.
3. Unit shall discharge supply air vertically or horizontally as shown on contract drawings.
4. Unit shall be factory configured for vertical supply & return configurations.
5. Unit shall be field convertible from vertical to horizontal airflow on all models. No special kit required on 036 through 150 models. Supply duct kit required for 180 model only.
6. Unit shall be capable of mixed operation: vertical supply with horizontal return or horizontal supply with vertical return.

### 23 81 19.13.G. Electrical Requirements

1. Main power supply voltage, phase, and frequency must match those required by the manufacturer.

### 23 81 19.13.H. Unit Cabinet

1. Unit cabinet shall be constructed of G90 galvanized steel, and shall be bonderized and coated with a pre-painted baked enamel finish on all externally exposed surfaces.
2. Unit cabinet exterior paint shall be: film thickness, (dry) 0.003 inches (.076mm) minimum, gloss (per ASTM D523, 60°F (16°C): 60, Hardness: H-2H Pencil hardness.
3. Evaporator fan compartment interior cabinet insulation shall conform to AHRI Standards 210/240 or 340/360 minimum exterior sweat criteria. Interior surfaces shall be insulated with a minimum 1/2-in. thick, 1 lb density, flexible fiberglass insulation, neoprene coated on the air side. Aluminum foil-faced fiberglass insulation shall be used in the gas heat compartment.
4. Base of unit shall have a minimum of four locations for thru-the-base gas and electrical connections (factory installed or field installed), standard.

#### 5. Base Rail

- a. Unit shall have base rails on a minimum of 2 sides.
- b. Holes shall be provided in the base rails for rigging shackles to facilitate maneuvering and overhead rigging.
- c. Holes shall be provided in the base rail for moving the rooftop by fork truck.
- d. Base rail shall be a minimum of 16 gauge thickness.

#### 6. Condensate pan and connections:

- a. Shall be a sloped condensate drain pan made of a non-corrosive material.
- b. Shall comply with ASHRAE Standard 62.
- c. Shall use a 3/4" -14 NPT drain connection, possible either through the bottom or end of the drain pan. Connection shall be made per manufacturer's recommendations.

#### 7. Top panel:

- a. Shall be a single piece top panel on 036 through 120/121 sizes, two pieces on 150 and 180 sizes.

#### 8. Gas Connections:

- a. All gas piping connecting to unit gas valve shall enter the unit cabinet at a single location on side of unit (horizontal plane).
- b. Thru-the-base capability
  - i. Standard unit shall have a thru-the-base gas-line location using a raised, embossed portion of the unit basepan.
  - ii. Optional, factory-approved, water-tight connection method must be used for thru-the-base gas connections.
  - iii. No basepan penetration, other than those authorized by the manufacturer, is permitted.

#### 9. Electrical Connections

- a. All unit power wiring shall enter unit cabinet at a single, factory-prepared, knockout location.
- b. Thru-the-base capability
  - i. Standard unit shall have a thru-the-base electrical location(s) using a raised, embossed portion of the unit basepan.
  - ii. Optional, factory-approved, water-tight connection method must be used for thru-the-base electrical connections.
  - iii. No basepan penetration, other than those authorized by the manufacturer, is permitted.

#### 10. Component access panels (standard)

- a. Cabinet panels shall be easily removable for servicing.
- b. Unit shall have one factory installed, tool-less, removable, filter access panel.
- c. Panels covering control box, indoor fan, indoor fan motor, gas components (where applicable), and compressors shall have a molded composite handles.
- d. Handles shall be UV modified, composite. They shall be permanently attached, and recessed into the panel.
- e. Screws on the vertical portion of all removable access panel shall engage into heat resistant, molded composite collars.
- f. Collars shall be removable and easily replaceable using manufacturer recommended parts.

### 23 81 19.13.I. Gas Heat

#### 1. General

- a. Heat exchanger shall be an induced draft design. Positive pressure heat exchanger designs shall not be allowed.
- b. Shall incorporate a direct-spark ignition system and redundant main gas valve.
- c. Heat exchanger design shall allow combustion process condensate to gravity drain; maintenance to drain the gas heat exchanger shall not be required.
- d. Gas supply pressure at the inlet to the rooftop unit gas valve must match that required by the manufacturer.

#### 2. The heat exchanger shall be controlled by an integrated gas controller (IGC) microprocessor.

- a. IGC board shall notify users of fault using an LED (light-emitting diode).
- b. IGC board shall contain algorithms that modify evaporator-fan operation to prevent future cycling on high temperature limit switch.
- c. Unit shall be equipped with anti-cycle protection with one short cycle on unit flame rollout switch or 4 continuous short cycles on the high temperature limit switch. Fault indication shall be made using an LED.

#### 3. Standard Heat Exchanger construction

- a. Heat exchanger shall be of the tubular-section type constructed of a minimum of 20-gauge steel coated with a nominal 1.2 mil aluminum-silicone alloy for corrosion resistance.
- b. Burners shall be of the in-shot type constructed of aluminum-coated steel.
- c. Burners shall incorporate orifices for rated heat output up to 2000 ft (610m) elevation. Additional accessory kits may be required for applications above 2000 ft (610m) elevation, depending on local gas supply conditions.
- d. Each heat exchanger tube shall contain multiple dimples for increased heating effectiveness.

4. Optional Stainless Steel Heat Exchanger construction

- a. Use energy saving, direct-spark ignition system
- b. Use a redundant main gas valve.
- c. Burners shall be of the in-shot type constructed of aluminum-coated steel.
- d. All gas piping shall enter the unit cabinet at a single location on side of unit (horizontal plane).
- e. The optional stainless steel heat exchanger shall be of the tubular-section type, constructed of a minimum of 20-gauge type 409 stainless steel.
- f. Type 409 stainless steel shall be used in heat exchanger tubes and vestibule plate.
- g. Complete stainless steel heat exchanger allows for greater application flexibility.

5. Optional Low NOx Heat Exchanger construction

- a. Low NOx reduction shall be provided to reduce nitrous oxide emissions to meet the California Air Quality Management District (SCAQMD) low-NOx emissions requirement of 40 nanograms per joule or less.
- b. Primary tubes and vestibule plates on low NOx units shall be 409 stainless steel. Other components shall be aluminum-coated steel.

6. Induced draft combustion motor and blower

- a. Shall be a direct-drive, single inlet, forward-curved centrifugal type.
- b. Shall be made from steel with a corrosion-resistant finish.
- c. Shall have permanently lubricated sealed bearings.
- d. Shall have inherent thermal overload protection.
- e. Shall have an automatic reset feature.

23 81 19.13.J. Coils

1. Standard Aluminum Fin – Copper Tube Coils:

- a. Standard evaporator and condenser coils shall have aluminum lanced plate fins mechanically bonded to seamless internally grooved copper tubes with all joints brazed.
- b. Evaporator coils shall be leak tested to 150 psig, pressure tested to 450 psig, and qualified to UL 1995 burst test at 1775 psig.
- c. Condenser coils shall be leak test at 150 psig, pressure tested to 650 psig, and qualified to UL 1995 burst test at 1980 psig.

2. Optional Pre-coated aluminum-fin condenser coils (3 Phase Models Only):

- a. Shall have a durable epoxy-phenolic coating to provide protection in mildly corrosive coastal environments.
- b. Coating shall be applied to the aluminum fin stock prior to the fin stamping process to create an inert barrier between the aluminum fin and copper tube.
- c. Epoxy-phenolic barrier shall minimize galvanic action between dissimilar metals.

3. Optional Copper-fin evaporator and condenser coils (3 Phase Models Only):

- a. Shall be constructed of copper fins mechanically bonded to copper tubes and copper tube sheets.
- b. Galvanized steel tube sheets shall not be acceptable.
- c. A polymer strip shall prevent coil assembly from contacting the sheet metal coil pan to minimize potential for galvanic corrosion between coil and pan.

4. Optional E-coated aluminum-fin evaporator and condenser coils (3 Phase Models Only):

- a. Shall have a flexible epoxy polymer coating uniformly applied to all coil surface areas without material bridging between fins.
- b. Coating process shall ensure complete coil encapsulation of tubes, fins and headers.
- c. Color shall be high gloss black with gloss per ASTM D523-89.
- d. Uniform dry film thickness from 0.8 to 1.2 mil on all surface areas including fin edges
- e. Superior hardness characteristics of 2H per ASTM D3363-92A and cross-hatch adhesion of 4B-5B per ASTM D3359-93.
- f. Impact resistance shall be up to 160 in.-lb (ASTM D2794-93).
- g. Humidity and water immersion resistance shall be up to minimum 1000 and 250 hours respectively (ASTM D2247-92 and ASTM D870-92).
- h. Corrosion durability shall be confirmed through testing to be no less than 1000 hours salt spray per ASTM B117-90.

23 81 19.13.K. Refrigerant Components

1. Refrigerant circuit shall include the following control, safety, and maintenance features:

- a. Fixed orifice metering system shall prevent mal-distribution of two-phase refrigerant by including multiple fixed orifice devices in each refrigeration circuit. Each orifice is to be optimized to the coil circuit it serves.

- b. Refrigerant filter drier – solid core design.
  - c. Service gauge connections on suction and discharge lines.
  - d. Pressure gauge access through a specially designed access port in the top panel of the unit.
2. There shall be gauge line access port in the skin of the rooftop, covered by a black, removable plug.
- a. The plug shall be easy to remove and replace.
  - b. When the plug is removed, the gauge access port shall enable maintenance personnel to route their pressure gauge lines.
  - c. This gauge access port shall facilitate correct and accurate condenser pressure readings by enabling the reading with the compressor access panel on.
  - d. The plug shall be made of a leak proof, UV-resistant, composite material.

3. Compressors

- a. Unit shall use fully hermetic, scroll compressor for each independent refrigeration circuit.
- b. Compressor motors shall be cooled by refrigerant gas passing through motor windings.
- c. Compressors shall be internally protected from high discharge temperature.
- d. Compressors shall be protected from an over-temperature and over-ampereage conditions by an internal, motor over-load device.
- e. Compressor shall be factory mounted on rubber grommets.
- f. Compressor motors shall have internal line break thermal, current overload and high pressure differential protection.
- g. Crankcase heaters shall not be required for normal operating range, unless required by compressor manufacturer due to refrigerant charge limits.

23 81 19.13.L. Filter Section

- 1. Filters access is specified in the unit cabinet section of this specification.
- 2. Filters shall be held in place by a pivoting filter tray, facilitating easy removal and installation.
- 3. Shall consist of factory-installed, low velocity, throw-away 2-in. thick fiberglass filters.
- 4. Filter face velocity shall not exceed 320 fpm at nominal airflows.
- 5. Filters shall be standard, commercially available sizes.
- 6. Only one size filter per unit is allowed.

23 81 19.13.M. Evaporator Fan and Motor

- 1. Evaporator fan motor:
  - a. Shall have permanently lubricated bearings
  - b. Shall have inherent automatic-reset thermal overload protection.
  - c. Shall have a maximum continuous bhp rating for continuous duty operation; no safety factors above that rating shall be required.
- 2. Belt-driven Evaporator Fan:
  - a. Belt drive shall include an adjustable-pitch motor pulley.
  - b. Shall use sealed, permanently lubricated ball-bearing type.
  - c. Blower fan shall be double-inlet type with forward-curved blades.
  - d. Shall be constructed from steel with a corrosion resistant finish and dynamically balanced.

23 81 19.13.N. Condenser Fans and Motors

- 1. Condenser fan motors:
  - a. Shall be a totally enclosed motor.
  - b. Shall use permanently lubricated bearings.
  - c. Shall have inherent thermal overload protection with an automatic reset feature.
  - d. Shall use a shaft-down design on 036 to 120/121 and 180 models and shaft-up on 150 models with rain shield.
- 2. Condenser Fans shall:
  - a. Shall be a direct-driven propeller type fan
  - b. Shall have aluminum blades riveted to corrosion-resistant steel spiders and shall be dynamically balanced.

23 81 19.13.O. Special Features

- 1. 2-Speed VFD drive motor system for 2-stage cooling models only:
  - a. Evaporator fan motor:
    - (1.) Shall have permanently lubricated bearings.
    - (2.) Shall have a maximum continuous bhp rating for continuous duty operation; no safety factors above that rating.
    - (3.) Shall be Variable Frequency duty and 2-speed control.
    - (4.) Shall contain motor shaft grounding ring to prevent electrical bearing fluting damage by safely diverting harmful shaft voltages and bearing currents to ground.
- 2. Variable Frequency Drive (VFD). Only available on 2-speed indoor fan motor option:
  - a. Shall be installed inside the unit cabinet, mounted, wired and tested.
  - b. Shall contain Electromagnetic Interference (EMI) frequency protection.

- c. Insulated Gate Bi-Polar Transistors (IGBT) used to produce the output pulse width modulated (PWM) waveform, allowing for quiet motor operation.
  - d. Self diagnostics with fault and power code LED indicator. Field accessory Display Kit available for further diagnostics and special setup applications.
  - e. RS485 capability standard.
  - f. Electronic thermal overload protection.
  - g. 5% swinging chokes for harmonic reduction and improved power factor.
  - h. All printed circuit boards shall be conformal coated.
3. Integrated Economizer IV, with standard leak rating for single speed indoor fan motor models. (Factory installed on 3 Phase Models Only. Field installed on all 3 and 1 Phase Models):
- a. Integrated, gear driven opposing modulating blade design type capable of simultaneous economizer and compressor operation
  - b. Independent modules for vertical or horizontal return configurations shall be available. Vertical return modules shall be available as a factory installed option.
  - c. Damper blades shall be galvanized steel with composite gears. Plastic or composite blades on intake or return shall not be acceptable.
  - d. Shall include all hardware and controls to provide free cooling with outdoor air when temperature and/or humidity are below setpoints.
  - e. Shall be equipped with gear driven dampers for both the outdoor ventilation air and the return air for positive air stream control.
  - f. Standard leak rate models shall be equipped with low-leakage dampers, not to exceed 2% leakage at 1 in. wg pressure differential.
  - g. Economizer controller on Economizer IV units shall be Honeywell W7212 that provides:
    - i. Combined minimum and DCV maximum damper position potentiometers with compressor staging relay
    - ii. Functions with solid state analog enthalpy or dry bulb changeover control sensing.
    - iii. Contain LED indicates for: when free cooling is available, when module is in DCV mode, when exhaust fan contact is closed.
  - h. Economizer controller on EconoMi\$er X models shall be the Honeywell W7220 that provides:
    - i. 2-line LCD interface screen for setup, configuration and troubleshooting
    - ii. On-board Fault Detection and Diagnostics (FDD) that senses and alerts when the economizer is not operating properly, per California Title 24.
    - iii. Sensor failure loss of communication identification
    - iv. Automatic sensor detection
    - v. Utilize digital sensors: Dry bulb and Enthalpy
  - i. Shall be capable of introducing up to 100% outdoor air.
  - j. Shall be equipped with a barometric relief damper capable of relieving up to 100% return air and contain seals that meet ASHRAE 90.1 requirements.
  - k. Shall be designed to close damper(s) during loss-of-power situations with spring return built into motor.
    - l. Dry bulb outdoor air temperature sensor shall be provided as standard. Enthalpy sensor is also available on factory installed only. Outdoor air sensor setpoint shall be adjustable and shall range from 40 to 100° F / 4 to 38° C. Additional sensor options shall be available as accessories.
  - m. The economizer controller shall also provide control of an accessory power exhaust unit function. Factory set at 100%, with a range of 0% to 100%.
  - n. The economizer shall maintain minimum airflow into the building during occupied period and provide design ventilation rate for full occupancy.
  - o. Dampers shall be completely closed when the unit is in the unoccupied mode.
  - p. Economizer controller shall accept a 2-10 Vdc CO2 sensor input for IAQ/DCV control. In this mode, dampers shall modulate the outdoor air damper to provide ventilation based on the sensor input.
  - q. Compressor lockout temperature on W7220 is adjustable from -45° F to 80° F, set at a factory default of 32° F. Others shall open at 35° F (2C) and closes at 50° F (10° C)
  - r. Actuator shall be direct coupled to economizer gear. No linkage arms or control rods shall be acceptable.
  - s. Economizer controller shall provide indications when in free cooling mode, in the DCV mode, or the exhaust fan contact is closed.
4. Integrated EconoMi\$er X Ultra Low Leak rate models. (Factory installed on 3 phase models only. Field installed on all 3 and 1 phase models)
- a. Integrated, gear driven opposing modulating blade design type capable of simultaneous economizer and compressor operation.
  - b. Independent modules for vertical or horizontal return configuration shall be available. Vertical return modules shall be available as a factory installed option.
  - c. Damper blades shall be galvanized steel with composite gears. Plastic or composite blades on intake or return shall not be acceptable.

- d. Shall include all hardware and controls to provide free cooling with outdoor air when temperature and/or humidity are below setpoints.
  - e. Shall be equipped with gear driven dampers for both the outdoor ventilation air and the return air for positive air stream control.
  - f. Ultra Low Leak design meets California Title 24 section 140.4 and ASHRAE 90.1 requirements of 4 cfm per sq. ft. on the outside air dampers and 10 cfm per sq. ft. on the return dampers.
  - g. Economizer controller on EconoMiSer X models shall be the Honeywell W7220 that provides:
    - i. 2-line LCD interface screen for setup, configuration and troubleshooting.
    - ii. On-board fault detection and diagnostics (FDD) that senses and alerts when the economizer is not operating properly, per California Title 24.
    - iii. Sensor failure loss of communication identification.
    - iv. Automatic sensor detection.
    - v. Capabilities for use with multiple-speed indoor fan systems.
    - vi. Utilize digital sensors: Dry bulb and Enthalpy.
  - h. Shall be capable of introducing up to 100% outdoor air.
    - i. Shall be equipped with a barometric relief damper capable of relieving up to 100% return air contain seals that meet ASHRAE 90.1 requirements.
    - j. Shall be designed to close damper(s) during loss-of-power situations with spring return built into motor.
  - k. Dry bulb outdoor air temperature sensor shall be provided as standard. Enthalpy sensor is also available on factory installed only. Outdoor air sensor setpoint shall be adjustable and shall range from 40° to 100°F / 4° to 38°C. Additional sensor options shall be available as accessories.
  - l. The economizer controller shall also provide control of an accessory power exhaust unit function. Factory set at 100%, with a range of 0% to 100%.
  - m. The economizer shall maintain minimum airflow into the building during occupied period and provide design ventilation rate for full occupancy.
  - n. Dampers shall be completely closed when the unit is in the unoccupied mode.
  - o. Economizer controller shall accept a 2-10 Vdc CO2 sensor input for IAQ/DCV control. In this mode, dampers shall modulate the outdoor air damper to provide ventilation based on the sensor input.
  - p. Compressor lockout temperature is adjustable from -45°F (-42°C) to 80°F (27°C), set at factory default of 32°F (0°C) .
  - q. Actuator shall be direct coupled to economizer gear. No linkage arms or control rods shall be acceptable.
  - r. Economizer controller shall provide indications when in free cooling mode, in the DCV mode, or the exhaust fan contact is closed.
5. Two-Position Damper (Factory installed on 3 Phase Models Only. Field installed on all 3 and 1 Phase Models)
- a. Damper shall be a Two-Position Damper. Damper travel shall be from the full closed position to the field adjustable %-open setpoint.
  - b. Damper shall include adjustable damper travel from 25% to 100% (full open).
  - c. Damper shall include single or dual blade, gear driven dampers and actuator motor.
  - d. Actuator shall be direct coupled to economizer gear. No linkage arms or control rods shall be acceptable.
  - e. Damper will admit up to 100% outdoor air for applicable rooftop units.
  - f. Damper shall close upon indoor (evaporator) fan shutoff and/or loss of power.
  - g. The damper actuator shall plug into the rooftop unit's wiring harness plug. No hard wiring shall be required.
  - h. Outside air hood shall include aluminum water entrainment filter
6. Manual damper
- a. Manual damper field installed accessory package shall consist of damper, air inlet screen, and rain hood which can be preset to admit up to 50% outdoor air for year round ventilation.
7. Hot Gas Reheat Adaptive Dehumidification System (3 Phase Models Only):
- a. The Hot Gas Reheat Adaptive Dehumidification System shall be factory installed and shall provide greater dehumidification of the occupied space by two modes of dehumidification operations in addition to its normal design cooling mode:
    - (1.) Subcooling mode further sub cools the hot liquid refrigerant leaving the condenser coil when both temperature and humidity in the space are not satisfied.
    - (2.) Hot gas reheat mode shall mix a portion of the hot gas from the discharge of the compressor with the hot liquid refrigerant leaving the condenser coil to create a two-phase heat transfer in the system, resulting in a neutral leaving air temperature when only humidity in the space is not satisfied.
    - (3.) Includes head pressure controller.
8. Head Pressure Control Package:
- a. Controller shall control coil head pressure by condenser-fan speed modulation or condenser-fan cycling and wind baffles.
  - b. Shall consist of solid-state control and condenser-coil temperature sensor to maintain condensing temperature between 90°F (32°C) and 110°F (43°C) at outdoor ambient temperatures down to -20°F (-29°C).
9. Liquid Propane (LP) Conversion Kit:

- a. Package shall contain all the necessary hardware and instructions to convert a standard natural gas unit for use with liquefied propane, up to 2000 ft (610m) elevation.
  - b. Additional accessory kits may be required for applications above 2000 ft (610m) elevation.
- 10.Flue Shield (036 through 150 Models Only):
- a. Flue shield shall provide protection from the hot sides of the gas flue hood.
- 11.Condenser Coil Hail Guard Assembly (Factory installed on 3 Phase Models Only. Field installed on all 3 and 1 Phase Models):
- a. Shall protect against damage from hail.
  - b. Shall be either hood style or louvered.
- 12.Unit–Mounted, Non–Fused Disconnect Switch (Available on units with FLA electrical ratings of 80 amps or less):
- a. Switch shall be factory–installed, internally mounted.
  - b. National Electric Code (NEC) and UL approved non–fused switch shall provide unit power shutoff.
  - c. Shall be accessible from outside the unit
  - d. Shall provide local shutdown and lockout capability.
- 13.Convenience Outlet:
- a. Non–Powered convenience outlet.
  - b. Outlet shall be powered from a separate 115–120v power source.
  - c. A transformer shall not be included.
  - d. Outlet shall be factory–installed and internally mounted with easily accessible 115–v female receptacle.
  - e. Outlet shall include 15 amp GFI receptacles with independent fuse protection.
  - f. Outlet shall be accessible from outside the unit.
  - g. Outlet shall include a field installed “Wet in Use” cover.
- 14.Flue Discharge Deflector (036 through 150 Models Only):
- a. Flue discharge deflector shall direct unit exhaust vertically instead of horizontally.
  - b. Deflector shall be defined as a “natural draft” device by the National Fuel and Gas (NFG) code.
- 15.Thru–the–Base Connectors:
- a. Kits shall provide connectors to permit gas and electrical connections to be brought to the unit through the unit base–pan.
  - b. Maximum of four connection locations per unit.
- 16.Supply Duct Cover (180 Models Only):
- a. Required when field converting the factory standard vertical duct supply to horizontal duct supply configuration. One required per unit.
- 17.Propeller Power Exhaust:
- a. Power exhaust shall be used in conjunction with an integrated economizer.
  - b. Independent modules for vertical or horizontal return configurations shall be available.
  - c. Horizontal power exhaust is shall be mounted in return ductwork.
  - d. Power exhaust shall be controlled by economizer controller operation. Exhaust fans shall be energized when dampers open past the 0–100% adjustable setpoint on the economizer control.
- 18.Roof Curbs (Vertical):
- a. Full perimeter roof curb with exhaust capability providing separate airstreams for energy recovery from the exhaust air without supply air contamination.
  - b. Formed galvanized steel with wood nailer strip and shall be capable of supporting entire unit weight.
  - c. Permits installation and securing of ductwork to curb prior to mounting unit on the curb.
- 19.High–Altitude Gas Conversion Kit:
- a. Package shall contain all the necessary hardware and instructions to convert a standard natural gas unit to operate from 2000–7000 ft (610 to 2134m) elevation with natural gas or from 0–7000 ft 90–2134m) elevation with liquefied propane.
- 20.High–Static Indoor Fan Motor(s) and Drive(s):
- a. Medium and High–static motor(s) and drive(s) shall be factory–installed to provide additional performance range.
- 21.Condenser Coil Grille:
- a. The grille protects the condenser coil from damage by large objects without increasing unit clearances.
- 22.Outdoor Air Enthalpy Sensor:
- a. The outdoor air enthalpy sensor shall be used to provide single enthalpy control. When used in conjunction with a return air enthalpy sensor, the unit will provide differential enthalpy control. The sensor allows the unit to determine if outside air is suitable for free cooling.
- 23.Return Air Enthalpy Sensor:
- a. The return air enthalpy sensor shall be used in conjunction with an outdoor air enthalpy sensor to provide differential enthalpy control.
- 24.Indoor Air Quality (CO2) Sensor:
- a. Shall be able to provide demand ventilation indoor air quality (IAQ) control.



b. The IAQ sensor shall be available in duct mount. The set point shall have adjustment capability.

25. Smoke detector:

- a. Shall be a Four–Wire Controller and Detector.
- b. Shall be environmental compensated with differential sensing for reliable, stable, and drift–free sensitivity.
- c. Shall use magnet–activated test/reset sensor switches.
- d. Shall have tool–less connection terminal access.
- e. Shall have a recessed momentary switch for testing and resetting the detector.
- f. Controller shall include:
  - i. One set of normally open alarm initiation contacts for connection to an initiating device circuit on a fire alarm control panel
  - ii. Two Form–C auxiliary alarm relays for interface with rooftop unit or other equipment
  - iii. One Form–C supervision (trouble) relay to control the operation of the Trouble LED on a remote test/reset station
  - iv. Capable of direct connection to two individual detector modules
  - v. Can be wired to up to 14 other duct smoke detectors for multiple fan shutdown applications

26. Winter start kit

- a. Shall contain a bypass device around the low pressure switch.
- b. Shall be required when mechanical cooling below an outdoor ambient of 40°F (4°C) to 25°F (–4°C).
- c. Shall not be required to operate an equipped economizer when below an outdoor ambient of 40°F (4°C).

27. Time Guard

- a. Shall prevent compressor short cycling by providing a 5–minute delay (±2 minutes) before restarting a compressor after shutdown for any reason.
- b. One device shall be required per compressor.

28. Phase Monitor Control

- a. Field installed accessory that provides phase loss / phase reversal protection.
- b. Mounts in unit control box and connects to unit main terminal board.

29. Hinged Access Panels

- a. Shall provide easy access through integrated quarter turn latches.
- b. Shall be on major panels of – filter, control box, fan motor and compressor

30. Display Kit for Variable frequency Drive

- a. Kit allows ability to access the VFD controller programs to provide special setup capabilities and diagnostics.
- b. Kit contains display module and communications cable.
- c. Display can be permanently installed in the unit or used on any compatible 2–speed indoor fan system VFD controller as needed.