

# INSTALLATION INSTRUCTIONS

## R-410A Single-Package Rooftop Gas Heating / Electric Cooling RGS036-072

**NOTE:** Read the entire instruction manual before starting the installation

### TABLE OF CONTENTS

<p>SAFETY CONSIDERATIONS ..... 2</p> <p style="padding-left: 20px;">Rated Indoor Airflow (cfm) ..... 3</p> <p>INSTALLATION ..... 6</p> <p style="padding-left: 20px;">Jobsite Survey ..... 6</p> <p style="padding-left: 20px;">Step 1 - Plan for Unit Location ..... 6</p> <p style="padding-left: 40px;">Roof Mount ..... 7</p> <p style="padding-left: 20px;">Step 2 - Plan for Sequence of Unit Installation ..... 7</p> <p style="padding-left: 40px;">Curb-Mount Installation ..... 7</p> <p style="padding-left: 40px;">Pad-Mount Installation ..... 7</p> <p style="padding-left: 40px;">Frame-Mount Installation ..... 7</p> <p style="padding-left: 20px;">Step 3 - Inspect Unit ..... 7</p> <p style="padding-left: 20px;">Step 4 - Provide Unit Support ..... 8</p> <p style="padding-left: 40px;">Roof Curb Mount ..... 8</p> <p style="padding-left: 40px;">Slab Mount (Horizontal Units Only) ..... 8</p> <p style="padding-left: 40px;">Alternate Unit Support (In Lieu of Curb or Slab Mount) ..... 8</p> <p style="padding-left: 20px;">Step 5 - Field Fabricate Ductwork ..... 10</p> <p style="padding-left: 20px;">Step 6 - Rig and Place Unit ..... 10</p> <p style="padding-left: 40px;">Positioning on Curb ..... 11</p> <p style="padding-left: 20px;">Step 7 - Convert to Horizontal &amp; Connect Ductwork . 11</p> <p style="padding-left: 20px;">Step 8 - Install Outside Air Hood ..... 11</p> <p style="padding-left: 40px;">Economizer and Two Position Damper Hood Package Removal and Setup — Factory Option . 11</p> <p style="padding-left: 40px;">Economizer Hood and Two-Position Hood ..... 12</p> <p style="padding-left: 20px;">Step 9 - Install Flue Hood ..... 12</p>	<p style="padding-left: 20px;">Step 10 - Install Gas Piping ..... 12</p> <p style="padding-left: 40px;">Factory-Option Thru-Base Connections (Gas Connections) ..... 13</p> <p style="padding-left: 20px;">Step 11 - Install External Condensate Trap and Line .. 15</p> <p style="padding-left: 20px;">Step 12 - Make Electrical Connections ..... 16</p> <p style="padding-left: 40px;">Field Power Supply ..... 16</p> <p style="padding-left: 40px;">Units with Factory-Installed Non-Fused Disconnect ..... 16</p> <p style="padding-left: 40px;">Units without Factory-Installed Non-Fused Disconnect ..... 17</p> <p style="padding-left: 40px;">All Units ..... 17</p> <p style="padding-left: 40px;">Convenience Outlets ..... 18</p> <p style="padding-left: 40px;">Factory-Option Thru-Base Connections (Electrical Connections) ..... 18</p> <p style="padding-left: 40px;">Units without Thru-Base Connections ..... 18</p> <p style="padding-left: 40px;">Field Control Wiring ..... 19</p> <p style="padding-left: 40px;">Thermostat ..... 19</p> <p style="padding-left: 40px;">Unit without Thru-Base Connection Kit ..... 19</p> <p style="padding-left: 40px;">Heat Anticipator Settings ..... 19</p> <p style="padding-left: 40px;">EconoMi\$er X (Factory-Installed Option) ..... 19</p> <p style="padding-left: 40px;">Hot Gas Re-Heat Control Connections ..... 20</p> <p style="padding-left: 40px;">Hot Gas Re-Heat - Space RH Controller ..... 20</p> <p style="padding-left: 40px;">Smoke Detectors ..... 22</p> <p style="padding-left: 20px;">Step 13 - Adjust Factory-Installed Options ..... 25</p> <p style="padding-left: 20px;">Step 14 - Install Accessories ..... 25</p> <p>START-UP CHECKLIST ..... 27</p>
--	---

## SAFETY CONSIDERATIONS

Improper installation, adjustment, alteration, service, maintenance, or use can cause explosion, fire, electrical shock or other conditions which may cause personal injury or property damage. Consult a qualified installer, service agency, or your distributor or branch for information or assistance. The qualified installer or agency must use factory-authorized kits or accessories when modifying this product. Refer to the individual instructions packaged with the kits or accessories when installing.

Follow all safety codes. Wear safety glasses and work gloves. Use quenching cloths for brazing operations and have a fire extinguisher available. Read these instructions thoroughly and follow all warnings or cautions attached to the unit. Consult local building codes and appropriate national electrical codes (in USA, ANSI/NFPA 70, National Electrical Code (NEC); in Canada, CSA C22.1) for special requirements.

It is important to recognize safety information. This is the safety-alert symbol . When you see this symbol on the unit and in instructions or manuals, be alert to the potential for personal injury.

Understand the signal words DANGER, WARNING, CAUTION, and NOTE. These words are used with the safety-alert symbol. DANGER identifies the most serious hazards which **will** result in severe personal injury or death. WARNING signifies hazards which **could** result in personal injury or death. CAUTION is used to identify unsafe practices, which **may** result in minor personal injury or product and property damage. NOTE is used to highlight suggestions which **will** result in enhanced installation, reliability, or operation.

### WARNING

#### FIRE, EXPLOSION HAZARD

Failure to follow this warning could result in personal injury or death.

Disconnect gas piping from unit when leak testing at pressure greater than 0.5 psig (3450 Pa). Pressures greater than 0.5 psig (3450 Pa) will cause gas valve damage resulting in hazardous condition. If gas valve is subjected to pressure greater than 0.5 psig (3450 Pa), it must be replaced before use. When pressure testing field-supplied gas piping at pressures of 0.5 psig (3450 Pa) or less, a unit connected to such piping must be isolated by closing the manual gas valve.

### WARNING

#### ELECTRICAL SHOCK HAZARD

Failure to follow this warning could cause personal injury or death.

Before performing service or maintenance operations on unit, turn off main power switch to unit and install lock(s) and lockout tag(s). Ensure electrical service to rooftop unit agrees with voltage and amperage listed on the unit rating plate. Unit may have more than one power switch.

### WARNING

#### UNIT OPERATION AND SAFETY HAZARD

Failure to follow this warning could cause personal injury, death and/or equipment damage.

R-410A refrigerant systems operate at higher pressures than standard R-22 systems. Do not use R-22 service equipment or components on R-410A refrigerant equipment.

### WARNING

#### PERSONAL INJURY AND ENVIRONMENTAL HAZARD

Failure to follow this warning could cause personal injury or death.

Relieve pressure and recover all refrigerant before system repair or final unit disposal.

Wear safety glasses and gloves when handling refrigerants. Keep torches and other ignition sources away from refrigerants and oils.

### CAUTION

#### CUT HAZARD

Failure to follow this caution may result in personal injury.

Sheet metal parts may have sharp edges or burrs. Use care and wear appropriate protective clothing, safety glasses and gloves when handling parts and servicing air conditioning equipment.

## Rated Indoor Airflow (cfm)

The table to the right lists the rated indoor airflow used for the AHRI efficiency rating for the units covered in this document.

Model Number	Full Load Airflow (cfm)
RGS036	1275
RGS048	1400
RGS060	1800
RGS072	2200

## MODEL NOMENCLATURE

MODEL SERIES	R	G	S	0	3	6	H	D	A	A	0	A	A	A
Position Number	1	2	3	4	5	6	7	8	9	10	11	12	13	14
R = Rooftop														
G = Gas/Electric	<b>Type</b>													
S = Standard ASHRAE 90.1-2010 Efficiency	<b>Efficiency</b>													
036 = 3 Tons 048 = 4 Tons 060 = 5 Tons 072 = 6 Tons			<b>Nominal Cooling Capacity</b>											
K = 208/230-1-60 H = 208/230-3-60 L = 460-3-60 S = 575-3-60						<b>Voltage</b>								
D = Low Heat E = Medium Heat F = High Heat L = Low Heat, Low NO <sub>x</sub> M = Medium Heat, Low NO <sub>x</sub> N = High Heat, Low NO <sub>x</sub>	S = Low Heat, Stainless Steel Heat Exchanger R = Medium Heat, Stainless Steel Heat Exchanger T = High Heat, Stainless Steel Heat Exchanger							<b>Heating Capacity</b>						
A = Belt Drive, Standard Static Motor B = Belt Drive, High Static Motor C = Belt Drive, Medium Static Motor X = Direct Drive, Standard Static (3, 4, and 5 ton models only)								<b>Motor Option (Indoor Fan)</b>						
A = None B = Economizer w/Baro-relief, OA Temp sensor E = Economizer w/Baro-relief + CO <sub>2</sub> Sensor, OA Temp sensor H = Economizer w/Baro-relief, enthalpy sensor L = Economizer w/Baro-relief + CO <sub>2</sub> Sensor, enthalpy sensor U = Temp Ultra Low Leak Economizer w/Baro-relief W = Enthalpy Ultra Low Leak Economizer w/Baro-relief P = 2-Position damper								<b>Outdoor Air Options / Control</b>						
0A = No Options AT = Non-powered 115v C.O. 4B = Non-Fused Disconnect BR = Supply Air Smoke Detector AA = Easy Access Hinged Panels								<b>Factory Installed Options<sup>1</sup></b>						
A = Aluminum / Copper Cond & Evap Coil B = Precoat Alum/Copper Cond with Alum / Copper Evap (3 phase only) C = E-Coated Alum/Copper Cond with Alum / Copper Evap (3 phase only) D = E-Coated Alum / Copper Cond & Evap (3 phase only) E = Copper/Copper Cond & Alum/Copper Evap (3 phase only) F = Copper/Copper Cond & Evap (3 phase only)								<b>Condenser / Evaporator Coil Configuration</b>						
A = Standard Single Speed Indoor Fan Motor. For W7212 Controls B = Standard Single Speed Indoor Fan Motor. For W7220 Controls								<b>Motor Type Option</b>						

**NOTE:** Factory installed options are NOT available on single phase models. This includes economizers and 2 position dampers.

<sup>1</sup>Combinations of FIOPS are available.

C150163

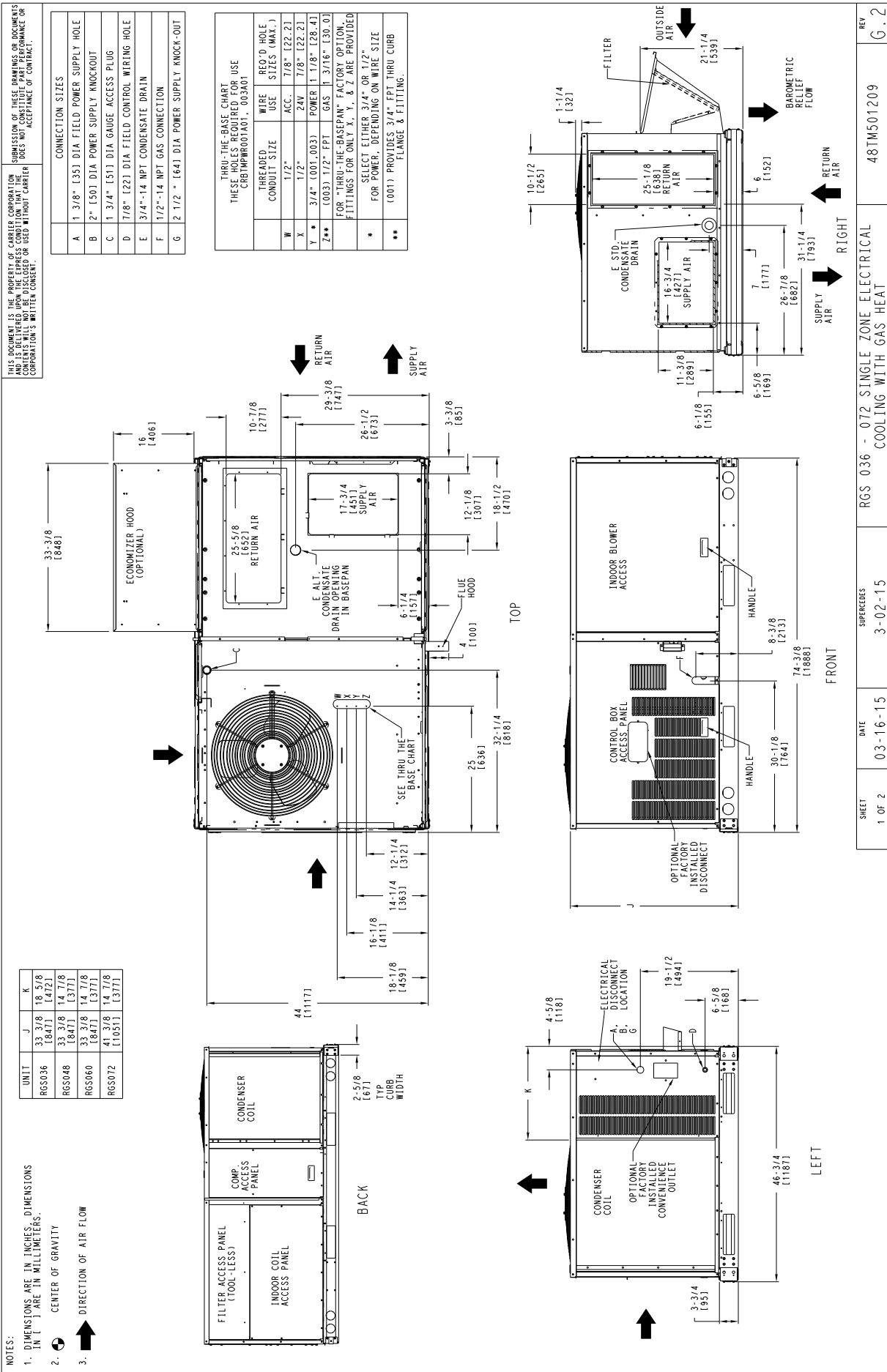

Fig 1 - Unit Dimensional Drawing

C150164

THIS DOCUMENT IS THE PROPERTY OF CABRIER CORPORATION AND IS DELIVERED UPON THE EXPRESS CONDITION THAT THE USER SHALL NOT REPRODUCE, COPIY, OR TRANSMIT THE INFORMATION CONTAINED HEREIN WITHOUT THE WRITTEN CONSENT OF CABRIER CORPORATION.

UNIT	STD. UNIT WEIGHT*		CORNER WEIGHT (A)		CORNER WEIGHT (B)		CORNER WEIGHT (C)		CORNER WEIGHT (D)		C.G.			WEIGHT			
	LBS.	KG.	LBS.	KG.	LBS.	KG.	LBS.	KG.	LBS.	KG.	X	Y	Z	LBS.	KG.		
RGS036	480	218	102	46	117	53	139	63	122	55	39	[991]	25	[635]	16	3/8	[416]
RGS048	528	239	127	58	125	57	137	62	139	63	37	[940]	24	[610]	17	1/4	[432]
RGS060	560	254	126	57	136	62	155	70	144	65	38	[965]	24	[610]	17	1/4	[438]
RGS072	652	296	150	68	169	76	176	80	157	71	39	[991]	23	[584]	20	1/8	[511]

\* STANDARD UNIT WEIGHT IS WITH LOW GAS HEAT AND WITHOUT PACKAGING. FOR OTHER OPTIONS AND ACCESSORIES, REFER TO THE PRODUCT DATA CATALOG.

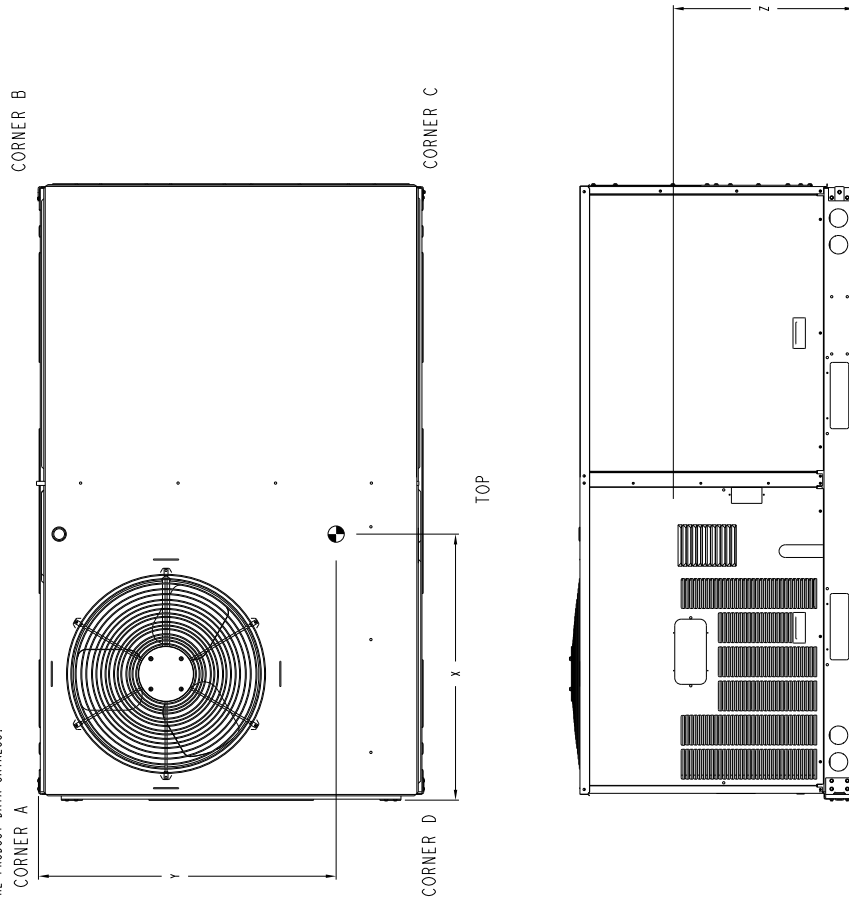

SHEET 2 OF 2	DATE 03-16-15	SUPERSEDES 3-02-15	RGS 036 - 072 SINGLE ZONE ELECTRICAL COOLING WITH GAS HEAT	48TM501209	REV G-2
-----------------	------------------	-----------------------	---	------------	------------

Fig. 1 - Unit Dimensional Drawing (cont.)

C150165

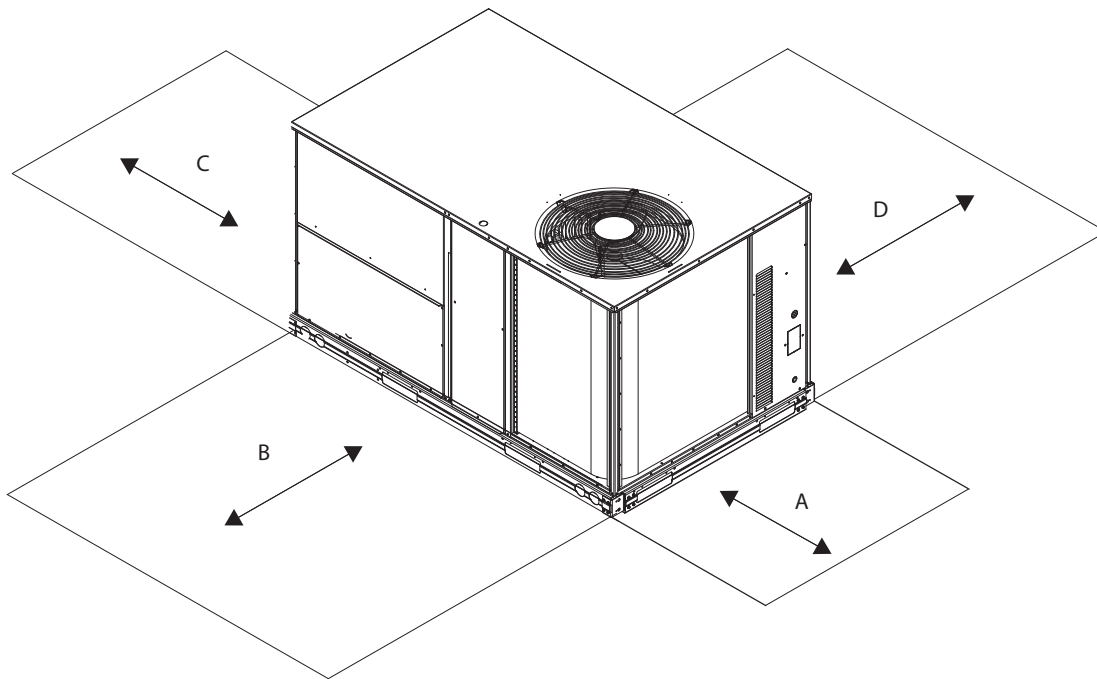

C08337

LOCATION	DIMENSION	CONDITION
A	48-in (1219 mm) 18-in (457 mm) 18-in (457 mm) 12-in (305 mm)	Unit disconnect is mounted on panel No disconnect, convenience outlet option Recommended service clearance Minimum clearance
B	42-in (1067 mm) 36-in (914 mm) Special	Surface behind servicer is grounded (e.g., metal, masonry wall) Surface behind servicer is electrically non-conductive (e.g., wood, fiberglass) Check sources of flue products within 10-ft of unit fresh air intake hood
C	36-in (914 mm) 18-in (457 mm)	Side condensate drain is used Minimum clearance
D	48-in (1219 mm) 42-in (1067 mm) 36-in (914 mm) Special	No flue discharge accessory installed, surface is combustible material Surface behind servicer is grounded (e.g., metal, masonry wall, another unit) Surface behind servicer is electrically non-conductive (e.g., wood, fiberglass) Check for adjacent units or building fresh air intakes within 10-ft of this unit's flue outlet

**NOTE:** Unit not designed to have overhead obstruction. Contact Application Engineering for guidance on any application planning overhead obstruction or for vertical clearances.

**Fig. 2 - Service Clearance Dimensional Drawing**

## INSTALLATION

### Jobsite Survey

Complete the following checks before installation.

1. Consult local building codes and the NEC (National Electrical Code) ANSI/NFPA 70 for special installation requirements.
2. Determine unit location (from project plans) or select unit location.
3. Check for possible overhead obstructions which may interfere with unit lifting or rigging.

### Step 1 — Plan for Unit Location

Select a location for the unit and its support system (curb or other) that provides for the minimum clearances required for safety. This includes the clearance to combustible surfaces, unit performance and service access below, around and above unit as specified in unit drawings. See Fig. 2.

**NOTE:** Consider also the effect of adjacent units.

Be sure that unit is installed such that snow will not block the combustion intake or flue outlet.

Unit may be installed directly on wood flooring or on Class A, B, or C roof-covering material when roof curb is used.

Do not install unit in an indoor location. Do not locate air inlets near exhaust vents or other sources of contaminated air. For proper unit operation, adequate combustion and ventilation air must be provided in accordance with Section 5.3 (Air for Combustion and Ventilation) of the National Fuel Gas Code, ANSI Z223.1 (American National Standards Institute) and NFPA (National Fire Protection Association) 54 TIA--54--84--1. In Canada, installation must be in accordance with the CAN1--B149 installation codes for gas burning appliances.

Although unit is weatherproof, avoid locations that permit water from higher level runoff and overhangs to fall onto the unit.

Locate mechanical draft system flue assembly at least 4 ft (1.2 m) from any opening through which combustion products could enter the building, and at least 4 ft (1.2 m) from any adjacent building (or per local code). Locate the flue assembly at least 10 ft (3.05 m) from an adjacent unit's fresh air intake hood if within 3 ft (0.91 m) of same elevation (or per local code). When unit is located adjacent to public walkways, flue assembly must be at least 7 ft (2.1 m) above grade.

Select a unit mounting system that provides adequate height to allow installation of condensate trap per requirements. Refer to Step 11 — Install External Condensate Trap and Line – for required trap dimensions.

**Roof Mount —**

Check building codes for weight distribution requirements. Unit operating weight is shown in Table 1.

**Step 2 — Plan for Sequence of Unit Installation**

The support method used for this unit will dictate different sequences for the steps of unit installation. For example, on curb-mounted units, some accessories must be installed on the unit before the unit is placed on the curb. Review the following for recommended sequences for installation steps.

**Curb-mounted Installation —**

- Install curb
- Install field-fabricated ductwork inside curb
- Install accessory thru-base service connection package (affects curb and unit) (refer to accessory installation instructions for details)
- Prepare bottom condensate drain connection to suit planned condensate line routing (refer to Step 11 for details)

- Rig and place unit
- Install outdoor air hood
- Install flue hood
- Install gas piping
- Install condensate line trap and piping
- Make electrical connections
- Install other accessories

**Pad-mounted Installation —**

- Prepare pad and unit supports
- Check and tighten the bottom condensate drain connection plug
- Rig and place unit
- Convert unit to side duct connection arrangement
- Install field-fabricated ductwork at unit duct openings
- Install outdoor air hood
- Install flue hood
- Install gas piping
- Install condensate line trap and piping
- Make electrical connections
- Install other accessories

**Frame-mounted Installation —**

Frame-mounted applications generally follow the sequence for a curb installation. Adapt as required to suit specific installation plan.

**Step 3 — Inspect Unit**

Inspect unit for transportation damage. File any claim with transportation agency.  
 Confirm before installation of unit that voltage, amperage and circuit protection requirements listed on unit data plate agree with power supply provided.

**Table 1 – Operating Weights**

RGS	UNITS LB (KG)			
	036	048	060	072
Base Unit	483 (219)	537 (244)	569 (258)	652 (296)
Economizer				
Vertical	50 (23)	50 (23)	50 (23)	50 (23)
Horizontal	80 (36)	80 (36)	80 (36)	80 (36)
Hot Gas Re-Heat System	N/A	N/A	N/A	41 (15)
Cu Fins	25 (11)	43 (20)	56 (25)	73 (33)
Unpowered Outlet	32 (15)	32 (15)	32 (15)	32 (15)
Curb				
14-in/356 mm	110 (50)	110 (50)	110 (50)	110 (50)
24-in/610 mm	145 (66)	145 (66)	145 (66)	145 (66)

## Step 4 — Provide Unit Support

### Roof Curb Mount —

Accessory roof curb details and dimensions are shown in Fig. 4. Assemble and install accessory roof curb in accordance with instructions shipped with the curb.

**NOTE:** The gasketing of the unit to the roof curb is critical for a watertight seal. Install gasket supplied with the roof curb as shown in Fig. 4. Improperly applied gasket can also result in air leaks and poor unit performance.

Curb should be level. This is necessary for unit drain to function properly. Unit leveling tolerances are shown in Fig. 3. Refer to Accessory Roof Curb Installation Instructions for additional information as required.

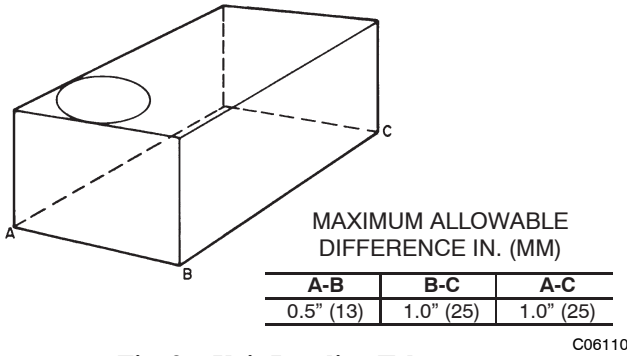

**Fig. 3 - Unit Leveling Tolerances**

Install insulation, cant strips, roofing felt, and counter flashing as shown. *Ductwork must be attached to curb and not to the unit. The accessory thru-the-base power and gas connection package must be installed before the unit is set on the roof curb.* If field-installed thru-the-roof curb gas connections are desired, use factory-supplied 1/2-in. pipe coupling and gas plate assembly to mount the thru-the-roof curb connection to the roof curb. Gas connections and power connections to the unit must be field installed after the unit is installed on the roof curb.

If electric and control wiring is to be routed through the basepan, attach the accessory thru-the-base service connections to the basepan in accordance with the accessory installation instructions.

### Slab Mount (Horizontal Units Only) —

Provide a level concrete slab that extends a minimum of 6 in. (150 mm) beyond unit cabinet. Install a gravel apron in front of condenser coil air inlet to prevent grass and foliage from obstructing airflow.

**NOTE:** Horizontal units may be installed on a roof curb if required.

### Alternate Unit Support (In Lieu of Curb or Slab Mount) —

A non-combustible sleeper rail can be used in the unit curb support area. If sleeper rails cannot be used, support the long sides of the unit with a minimum of 3 equally spaced 4-in. x 4-in. (102 mm x 102 mm) pads on each side.



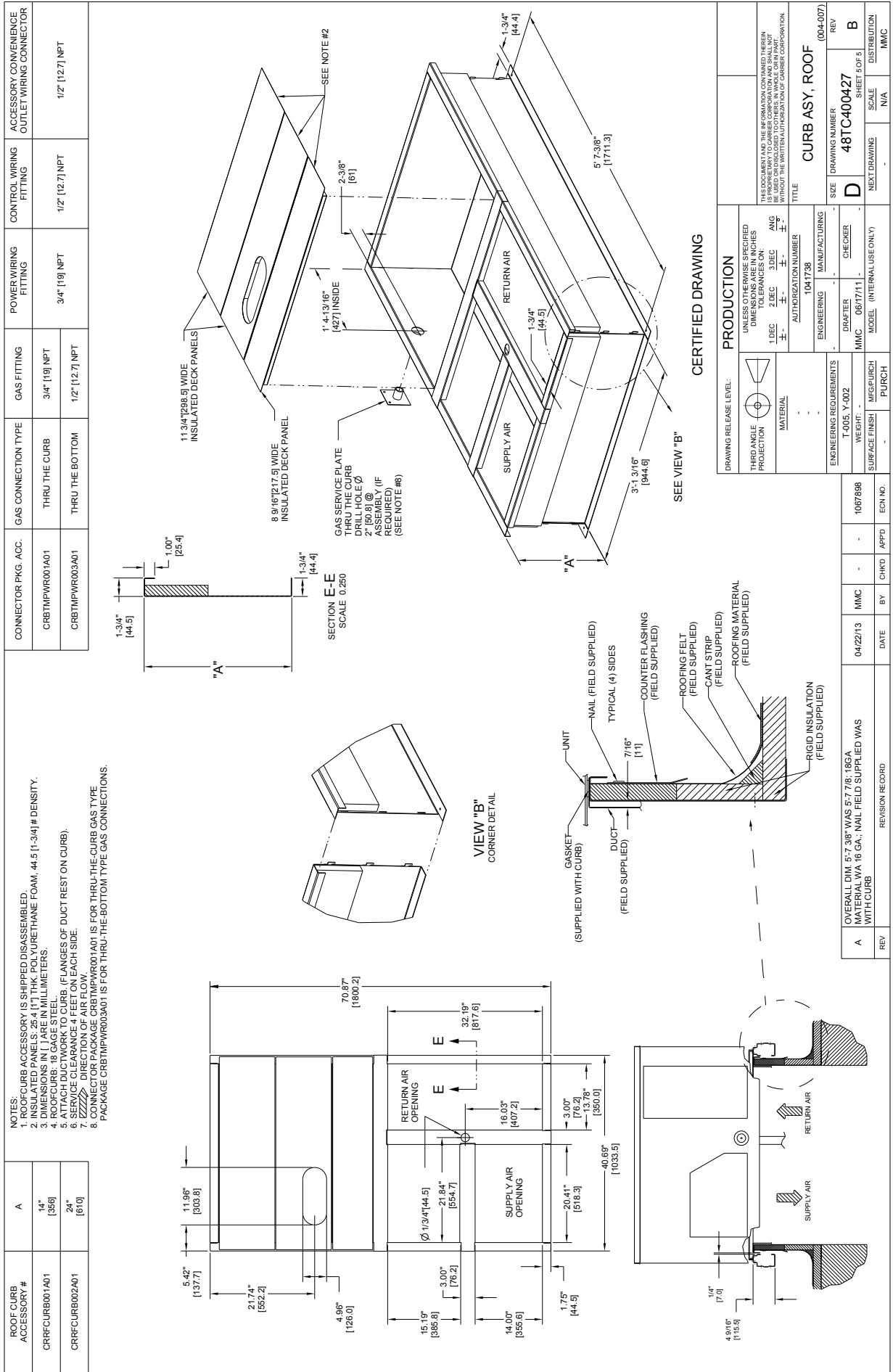

Fig. 4 - Roof Curb Details

## Step 5 — Field Fabricate Ductwork

Cabinet return-air static pressure (a negative condition) shall not exceed 0.35 in. wg (87 Pa) with economizer or 0.45 in. wg (112 Pa) without economizer.

For vertical ducted applications, secure all ducts to roof curb and building structure. *Do not connect ductwork to unit.*

Fabricate supply ductwork so that the cross sectional dimensions are equal to or greater than the unit supply duct opening dimensions for the first 18 in. (458 mm) of duct length from the unit basepan.

Insulate and weatherproof all external ductwork, joints, and roof openings with counter flashing and mastic in accordance with applicable codes.

Ducts passing through unconditioned spaces must be insulated and covered with a vapor barrier.

If a plenum return is used on a vertical unit, the return should be ducted through the roof deck to comply with applicable fire codes.

A minimum clearance is not required around ductwork.

## Step 6 — Rig and Place Unit

Keep unit upright and do not drop. Spreader bars are required. Rollers may be used to move unit across a roof. Level by using unit frame as a reference. See Table 1 and Fig. 5 for additional information.

Lifting holes are provided in base rails as shown in Fig. 5. Refer to rigging instructions on unit.

→ Rigging materials under unit (cardboard or wood to prevent base pan damage) must be removed PRIOR to placing the unit on the roof curb.

When using the standard side drain connection, ensure the red plug in the alternate bottom connection is tight. Do this before setting the unit in place. The red drain pan can be tightened with a 1/2-in. square socket drive extension. For further details see “Step 11 - Install External Condensate Trap and Line on page 15.

Before setting the unit onto the curb, recheck gasketing on curb.

**⚠ CAUTION**

**PROPERTY DAMAGE HAZARD**

Failure to follow this caution may result in damage to roofing materials.

Membrane roofs can be cut by sharp sheet metal edges. Be careful when placing any sheet metal parts on such roof.

**⚠ CAUTION**

**UNIT DAMAGE HAZARD**

Failure to follow this caution may result in equipment damage.

All panels must be in place when rigging. Unit is not designed for handling by fork truck.

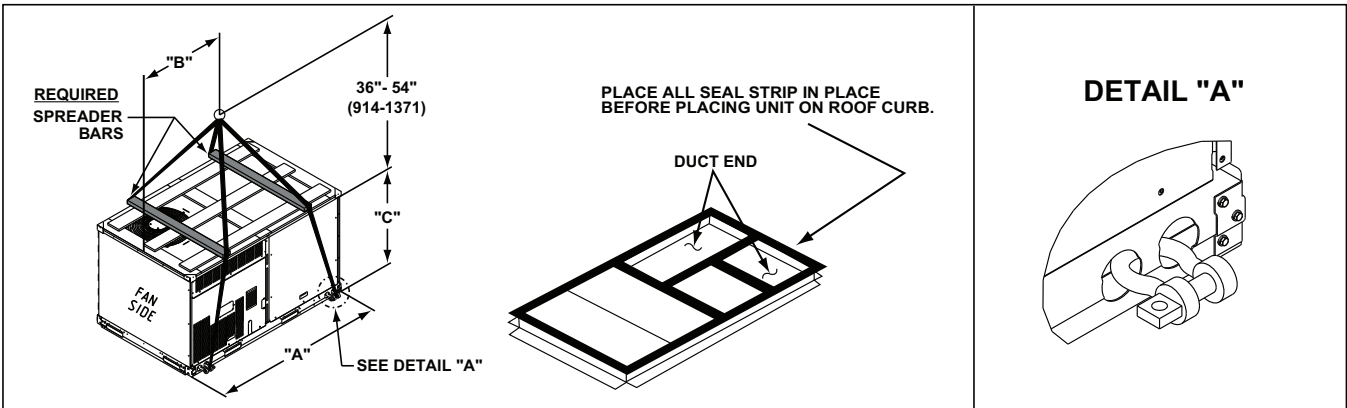

C11292

UNIT	MAX WEIGHT		DIMENSIONS					
			A		B		C	
	LB	KG	IN	MM	IN	MM	IN	MM
RGS036	520	236	74.5	1890	38.0	965	33.5	850
RGS048	575	261	74.5	1890	38.0	965	41.5	1055
RGS060	605	274	74.5	1890	37.5	955	41.5	1055
RGS072	690	313	74.5	1890	37.5	955	41.5	1055

**NOTES:**

1. SPREADER BARS REQUIRED — Top damage will occur if spreader bars are not used.
2. Dimensions in ( ) are in millimeters.
3. Hook rigging shackles through holes in base rail, as shown in detail “A.” Holes in base rails are centered around the unit center of gravity. Use wooden top to prevent rigging straps from damaging unit.

**Fig. 5 - Rigging Details**

## Positioning on Curb —

Position unit on roof curb so that the following clearances are maintained: 1/4 in. (6.4 mm) clearance between the roof curb and the base rail inside the front and rear, 0.0 in. clearance between the roof curb and the base rail inside on the duct end of the unit. This will result in the distance between the roof curb and the base rail inside on the condenser end of the unit being approximately 1/4 in. (6.4 mm).

Although unit is weatherproof, guard against water from higher level runoff and overhangs.

*Flue vent discharge must have a minimum horizontal clearance of 4 ft (1220 mm) from electric and gas meters, gas regulators, and gas relief equipment. Minimum distance between unit and other electrically live parts is 48 inches (1220 mm).*

Flue gas can deteriorate building materials. Orient unit such that flue gas will not affect building materials. Locate mechanical draft system flue assembly at least 48 in. (1220 mm) from an adjacent building or combustible material.

**NOTE:** Installation of accessory flue discharge deflector kit will reduce the minimum clearance to combustible material to 18 in. (460 mm).

After unit is in position, remove rigging skids and shipping materials.

## Step 7 — Convert to Horizontal and Connect Ductwork (when required)

Unit is shipped in the vertical duct configuration. Unit *without* factory-installed economizer or return air smoke detector option may be field-converted to horizontal ducted configuration. To convert to horizontal configuration, remove screws from side duct opening covers and remove covers. Using the same screws, install covers on vertical duct openings with the insulation-side down. Seals around duct openings must be tight. See Fig. 6

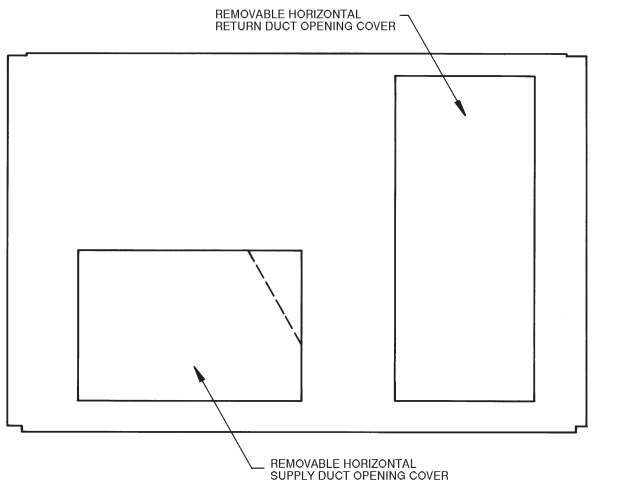

C06108

**Fig. 6 - Horizontal Conversion Panels**

Field-supplied flanges should be attached to horizontal duct openings and all ductwork should be secured to the flanges. Insulate and weatherproof all external ductwork, joints, and roof or building openings with counter flashing and mastic in accordance with applicable codes.

Do not cover or obscure visibility to the unit's informative data plate when insulating horizontal ductwork.

## Step 8 — Install Outside Air Hood

### Economizer and Two Position Damper Hood Package Removal and Setup - Factory Option

**NOTE:** Economizer and two position damper are not available as factory installed options for single phase (-K voltage code) models.

1. The hood is shipped in knock-down form and must be field assembled. The indoor coil access panel is used as the hood top while the hood sides, divider and filter are packaged together, attached to a metal support tray using plastic stretch wrap, and shipped in the return air compartment behind the indoor coil access panel. The hood assembly's metal tray is attached to the basepan and also attached to the damper using two plastic tie-wraps.
2. To gain access to the hood, remove the filter access panel. (See Fig. 7.)

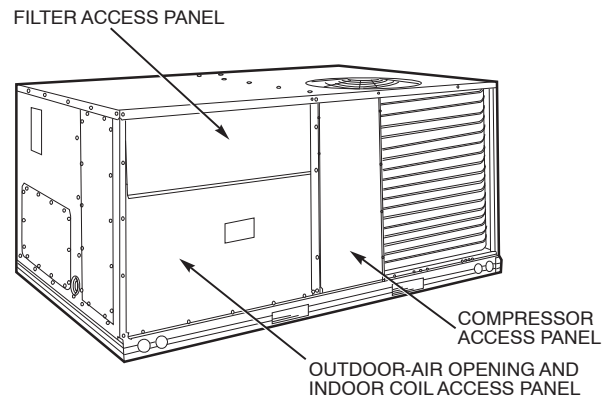

C06023

**Fig. 7 - Typical Access Panel Locations**

3. Locate the (2) screws holding the metal tray to the basepan and remove. Locate and cut the (2) plastic tie-wraps securing the assembly to the damper. (See Fig. 8) Be careful to not damage any wiring or cut tie-wraps securing any wiring.

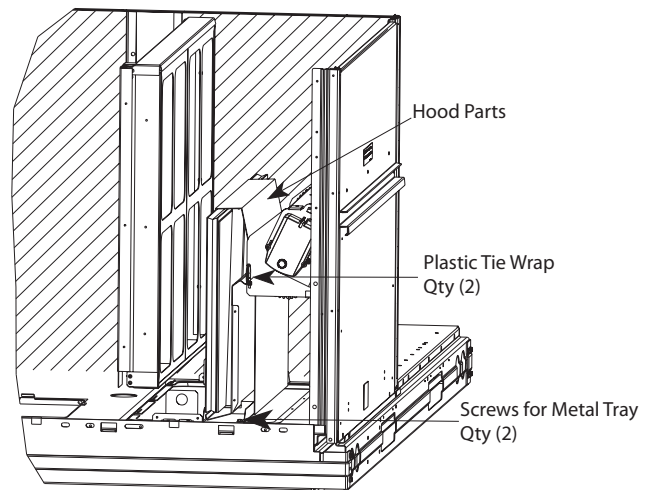

C08639

**Fig. 8 - Economizer and Two-Position Damper Hood Parts Location**

- Carefully lift the hood assembly (with metal tray) through the filter access opening and assemble per the steps outlined in *Economizer Hood and Two-Position Hood*, below.

### Economizer Hood and Two-Position Hood —

**NOTE:** If the power exhaust accessory is to be installed on the unit, the hood shipped with the unit will not be used and must be discarded. Save the aluminum filter for use in the power exhaust hood assembly.

- The indoor coil access panel will be used as the top of the hood. Remove the screws along the sides and bottom of the indoor coil access panel. See Fig. 9.

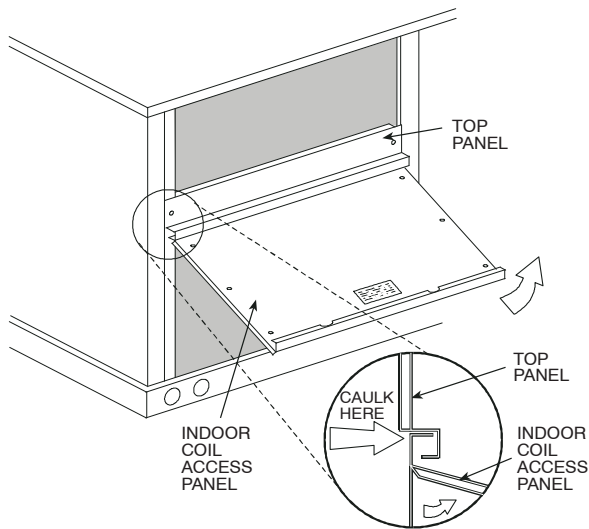

**Fig. 9 - Indoor Coil Access Panel Relocation**

C06025

- Swing out indoor coil access panel and insert the hood sides under the panel (hood top). Use the screws provided to attach the hood sides to the hood top. Use screws provided to attach the hood sides to the unit. See Fig. 10.

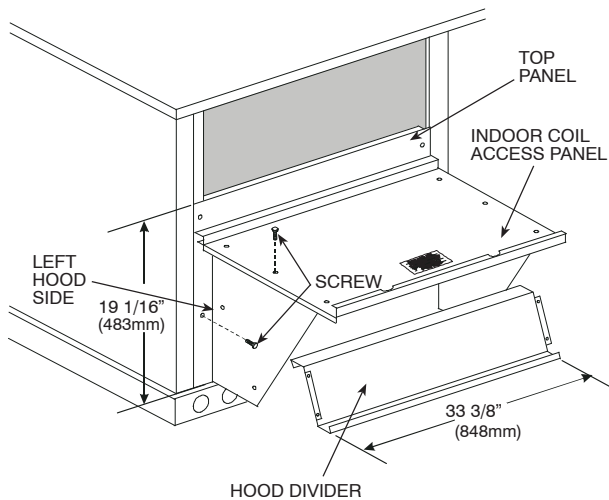

**Fig. 10 - Economizer Hood Construction**

C06026

- Remove the shipping tape holding the economizer barometric relief damper in place (economizer only).
- Insert the hood divider between the hood sides. See Fig. 10 and 11. Secure hood divider with 2 screws on

each hood side. The hood divider is also used as the bottom filter rack for the aluminum filter.

- Open the filter clips which are located underneath the hood top. Insert the aluminum filter into the bottom filter rack (hood divider). Push the filter into position past the open filter clips. Close the filter clips to lock the filter into place. See Fig. 11.
- Caulk the ends of the joint between the unit top panel and the hood top.
- Replace the filter access panel.

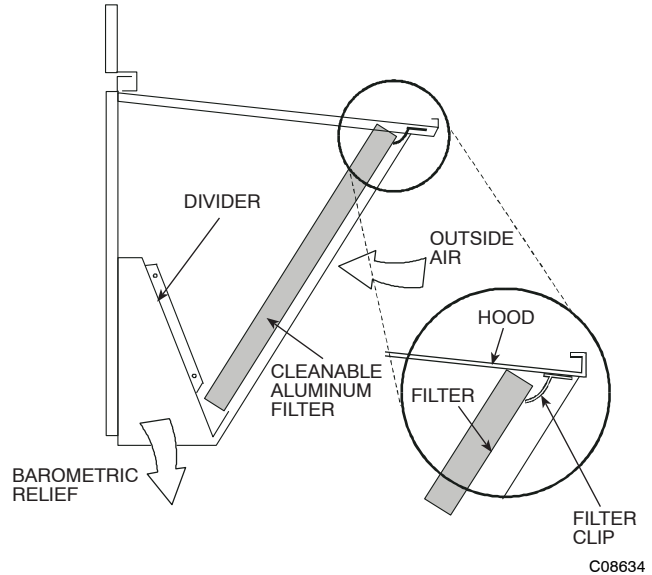
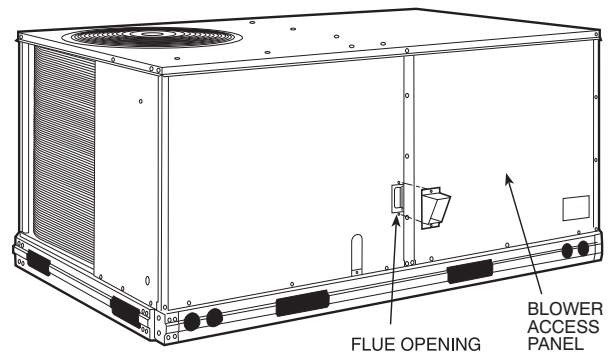

**Fig. 11 - Economizer Filter Installation**

C08634

### Step 9 — Install Flue Hood

Flue hood is shipped screwed to the basepan beside the burner compartment access panel. Remove from shipping location and using screws provided, install flue hood and screen in location shown in Fig. 12.



**Fig. 12 - Flue Hood Details**

C07081

### Step 10 — Install Gas Piping

Installation of the gas piping must be accordance with local building codes and with applicable national codes. In U.S.A., refer to NFPA 54/ANSI Z223.1 National Fuel Gas Code (NFGC). In Canada, installation must be accordance with the CAN/CSA B149.1 and CAN/CSA B149.2 installation codes for gas burning appliances.

This unit is factory equipped for use with Natural Gas fuel at elevations up to 2000 ft (610 m) above sea level. Unit

may be field converted for operation at elevations above 2000 ft (610 m) and/or for use with liquefied petroleum fuel. See accessory kit installation instructions regarding these accessories.

**NOTE:** Furnace gas input rate on rating plate is for installation up to 2000 ft (610 m) above sea level. In U.S.A. the input rating for altitudes above 2000 ft (610 m) must be derated by 4% for each 1000 ft (305 m) above sea level. In Canada the input rating must be derated by 10% for altitudes of 2000 ft (610 m) to 4500 ft (1372 m) above sea level.

For natural gas applications, gas pressure at unit gas connection must not be less than 4 in. wg (996 Pa) or greater than 13 in. wg (3240 Pa) while the unit is operating. For liquefied petroleum applications, the gas pressure must not be less than 11 in. wg (2740 Pa) or greater than 13.0 in. wg (3240 Pa) at the unit connection.

**Table 2 – Natural Gas Supply Line Pressure Ranges**

UNIT MODEL	UNIT SIZE	MIN	MAX
RGS	036, 048, 060, 072	4.0 in. wg (996 Pa)	13.0 in. wg (3240 Pa)

**Table 3 – Liquid Propane Supply Line Pressure Ranges**

UNIT MODEL	UNIT SIZE	MIN	MAX
RGS	036, 048, 060, 072	11.0 in. wg (2740 Pa)	13.0 in. wg (3240 Pa)

The gas supply pipe enters the unit at the burner access panel on the front side of the unit, through the long slot at the bottom of the access panel. The gas connection to the unit is made to the 1/2-in. FPT gas inlet port on the unit gas valve

Manifold pressure is factory-adjusted for NG fuel use. Adjust as required to obtain best flame characteristics.

**Table 4 – Natural Gas Manifold Pressure Ranges**

UNIT MODEL	UNIT SIZE	HIGH FIRE	LOW FIRE
RGS	036, 048, 060, 072	3.5 in. wg (872 Pa)	1.7 in. wg (423 Pa)

Manifold pressure for LP fuel use must be adjusted to specified range. Follow instructions in the accessory kit to make initial readjustment.

**Table 5 – Liquid Propane Manifold Pressure Ranges**

UNIT MODEL	UNIT SIZE	HIGH FIRE	LOW FIRE
RGS	036, 048, 060, 072	10.0 in. wg (2490 Pa)	5.0 in. wg (1245 Pa)

## ⚠ CAUTION

### EQUIPMENT DAMAGE HAZARD

Failure to follow this caution may result in damage to equipment.

When connecting the gas line to the unit gas valve, the installer **MUST** use a backup wrench to prevent damage to the valve.

Install a gas supply line that runs to the unit heating section. Refer to the NFPA 54/NFPA or equivalent code for gas pipe sizing data. Do not use a pipe size smaller than 1/2-in. Size the gas supply line to allow for a maximum pressure drop of 0.5-in wg (124 Pa) between gas regulator source and unit gas valve connection when unit is operating at high-fire flow rate.

The gas supply line can approach the unit in three ways: horizontally from outside the unit (across the roof), thru-curb/under unit basepan (accessory kit required) or through unit basepan (factory-option or accessory kit required). Consult accessory kit installation instructions for details on these installation methods. Observe clearance to gas line components per Fig. 13.

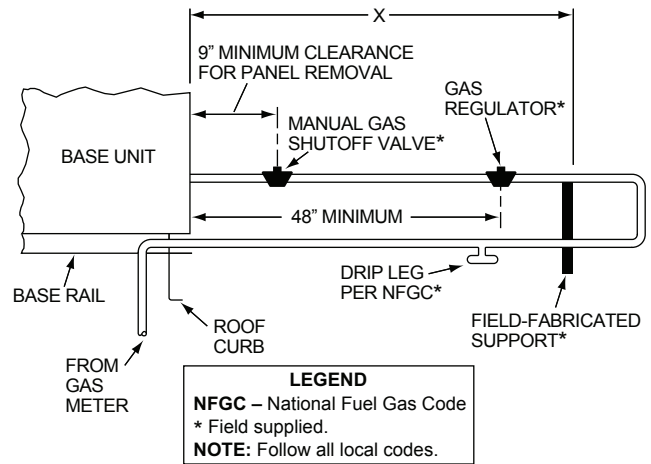

STEEL PIPE NOMINAL DIAMETER (in.)	SPACING OF SUPPORTS X DIMENSION (ft)
1/2	6
3/4 or 1	8
1 1/4 or larger	10

C11091

**Fig. 13 - Gas Piping Guide (with Accessory Thru-the-Curb Service Connections)**

### Factory-Option Thru-Base Connections (Gas Connections) —

This service connection kit consists of a 1/2-in NPT gas adapter fitting (brass), a 1/2-in electrical bulkhead connector and a 3/4-in electrical bulkhead connector, all factory-installed in the embossed (raised) section of the unit basepan in the condenser section.

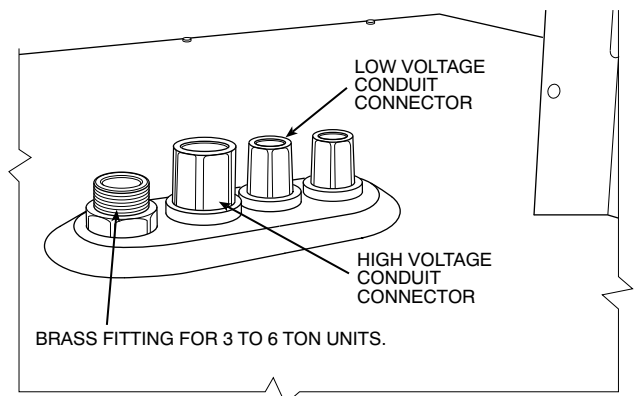

C13410

**Fig. 14 - Thru-Base Connection Fittings**

The thru-base gas connector has male and female threads. The male threads protrude above the basepan of the unit; the female threads protrude below the basepan.

Check tightness of connector lock nuts before connecting gas piping.

Install a 1/2-in NPT street elbow on the thru-base gas fitting. Attach a 1/2-in pipe nipple with minimum length of 16-in (406 mm) (field-supplied) to the street elbow and extend it through the access panel at the gas support bracket. See Fig. 15.

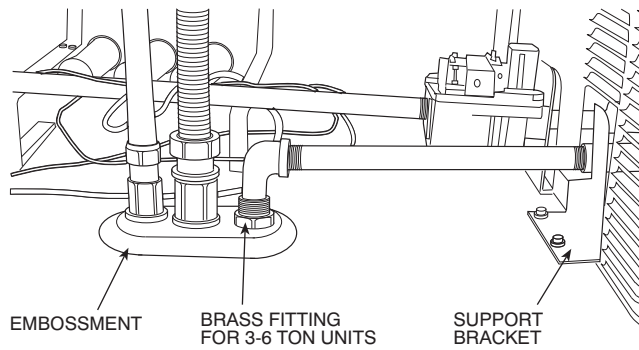

C08016

**Fig. 15 - Gas Line Piping for 3 to 6 Ton Units Only**

Other hardware required to complete the installation of the gas supply line will include a manual shutoff valve, a sediment trap (drip leg) and a ground-joint union. A pressure regulator valve may also be required (to convert gas pressure from pounds to inches of pressure). The manual shutoff valve must be located within 6-ft (1.83 m) of the unit. The union, located in the final leg entering the unit, must be located at least 9-in (230 mm) away from the access panel to permit the panel to be removed for service. If a regulator valve is installed, it must be located a minimum of 4-ft (1220 mm) away from the unit's flue outlet. Some municipal codes require that the manual shutoff valve be located upstream of the sediment trap. See Figures 16 and 17 for typical piping arrangements for gas piping that has been routed through the sidewall of the curb. See Fig. 18 for typical piping arrangement when thru-base is used. Ensure that all piping does not block access to the unit's main control box or limit the required working space in front of the control box.

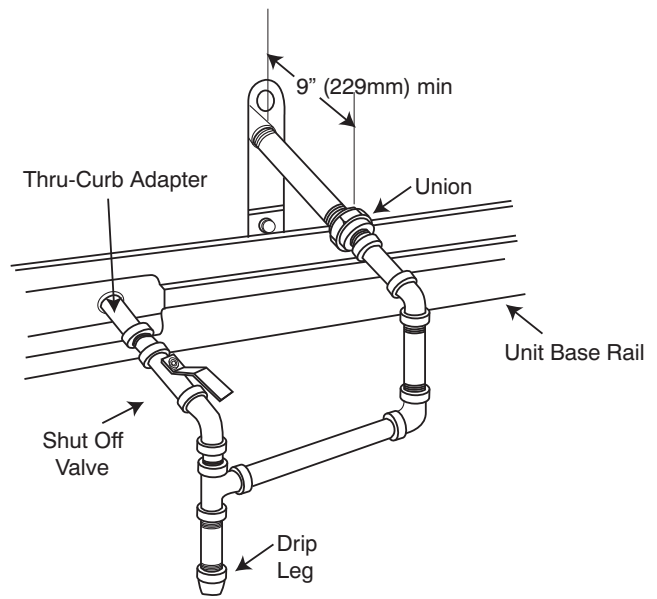

C07469

**Fig. 16 - Gas Piping**

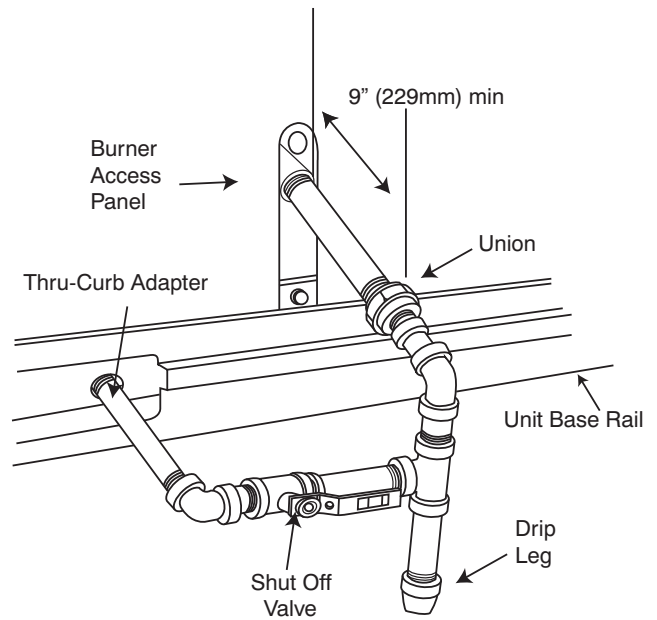

C07470

**Fig. 17 - Gas Piping**

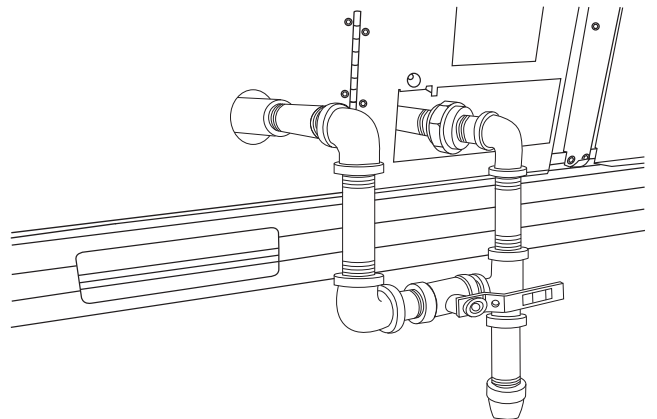

C08018

**Fig. 18 - Gas Piping Thru-Base Connections**

When installing the gas supply line, observe local codes pertaining to gas pipe installations. Refer to the NFPA 54/ANSI Z223.1 NFGC latest edition (in Canada, CAN/CSA B149.1). In the absence of local building codes, adhere to the following pertinent recommendations:

1. Avoid low spots in long runs of pipe. Grade all pipe  $\frac{1}{4}$ -in. in every 15 ft (7 mm in every 5 m) to prevent traps. Grade all horizontal runs downward to risers. Use risers to connect to heating section and to meter.
2. Protect all segments of piping system against physical and thermal damage. Support all piping with appropriate straps, hangers, etc. Use a minimum of one hanger every 6 ft (1.8 m). For pipe sizes larger than  $\frac{1}{2}$ -in., follow recommendations of national codes.
3. Apply joint compound (pipe dope) sparingly and only to male threads of joint when making pipe connections. Use only pipe dope that is resistant to action of liquefied petroleum gases as specified by local and/or national codes. If using PTFE (Teflon) tape, ensure the material is Double Density type and is labeled for use on gas lines. Apply tape per manufacturer's instructions.
4. Pressure-test all gas piping in accordance with local and national plumbing and gas codes before connecting piping to unit.

**NOTE:** Pressure test the gas supply system after the gas supply piping is connected to the gas valve. The supply piping must be disconnected from the gas valve during the testing of the piping systems when test pressure is in excess of 0.5 psig (3450 Pa). Pressure test the gas supply piping system at pressures equal to or less than 0.5 psig (3450 Pa). The unit heating section must be isolated from the gas piping system by closing the external main manual shutoff valve and slightly opening the ground-joint union. Check for gas leaks at the field-installed and factory-installed gas lines after all piping connections have been completed. Use soap-and-water solution (or method specified by local codes and/or regulations).

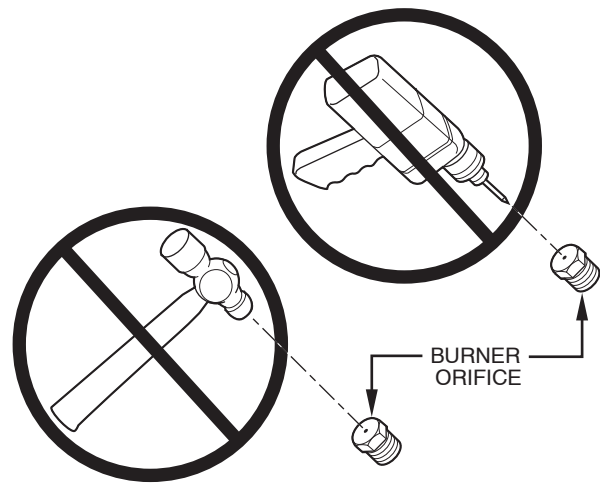

**Fig. 19 - Orifice Hole**

A93059

### Step 11 — Install External Condensate Trap and Line

The unit has one  $\frac{3}{4}$ -in. condensate drain connection on the end of the condensate pan and an alternate connection on the bottom. See Fig. 20. Unit airflow configuration does not determine which drain connection to use. Either drain connection can be used with vertical or horizontal applications.

When using the standard side drain connection, ensure the red plug in the alternate bottom connection is tight. Do this before setting the unit in place. The red drain pan can be tightened with a  $\frac{1}{2}$ -in. square socket drive extension.

To use the alternate bottom drain connection, remove the red drain plug from the bottom connection (use a  $\frac{1}{2}$ -in. square socket drive extension) and install it in the side drain connection.

The piping for the condensate drain and external trap can be completed after the unit is in place. See Fig. 21.

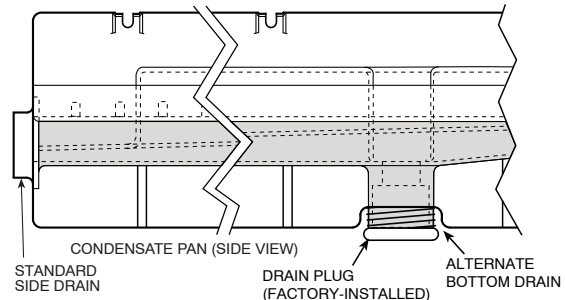

C08021

**Fig. 20 - Condensate Drain Pan (Side View)**

**NOTE:** If the alternate bottom drain is not used check the drain plug for tightness prior to setting the unit on the roof curb.

**⚠ WARNING**

**FIRE OR EXPLOSION HAZARD**

Failure to follow this warning could result in personal injury, death and/or property damage.

- Connect gas pipe to unit using a backup wrench to avoid damaging gas controls.
- Never purge a gas line into a combustion chamber.
- Never test for gas leaks with an open flame. Use a commercially available soap solution made specifically for the detection of leaks to check all connections.
- Use proper length of pipe to avoid stress on gas control manifold.

**NOTE:** If orifice hole appears damaged or it is suspected to have been redrilled, check orifice hole with a numbered drill bit of correct size. Never redrill an orifice. A burr-free and squarely aligned orifice hole is essential for proper flame characteristics.

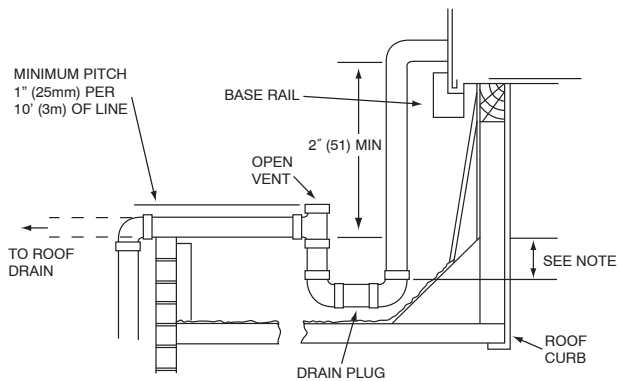

NOTE: Trap should be deep enough to offset maximum unit static difference. A 4" (102) trap is recommended

C08022

**Fig. 21 - Condensate Drain Piping Details**

All units must have an external trap for condensate drainage. Install a trap at least 4-in. (102 mm) deep and protect against freeze-up. If drain line is installed downstream from the external trap, pitch the line away from the unit at 1-in. per 10 ft (25 mm in 3 m) of run. Do not use a pipe size smaller than the unit connection (3/4-in.).

**Step 12 — Make Electrical Connections**

**⚠ WARNING**

**ELECTRICAL SHOCK HAZARD**

Failure to follow this warning could result in personal injury or death.

Do not use gas piping as an electrical ground. Unit cabinet must have an uninterrupted, unbroken electrical ground to minimize the possibility of personal injury if an electrical fault should occur. This ground may consist of electrical wire connected to unit ground lug in control compartment, or conduit approved for electrical ground when installed in accordance with NEC (National Electrical Code); ANSI/NFPA 70, latest edition (in Canada, Canadian Electrical Code CSA [Canadian Standards Association] C22.1), and local electrical codes.

NOTE: Field-supplied wiring shall conform with the limitations of minimum 63°F (33°C) rise.

**Field Power Supply —**

Field power wires are connected to the unit at line-side pressure lugs on compressor contactor C and indoor fan contactor IFC (see wiring diagram label for control box component arrangement) or at factory-installed option non-fused disconnect switch. Max wire size is #2 AWG (copper only). (See Fig. 22.)

NOTE: TEST LEADS - Unit may be equipped with short leads (pigtailed) on the field line connection points on contactor C or optional disconnect switch. These leads are for factory run-test purposes only; remove and discard before connecting field power wires to unit connection points. Make field power connections directly to line connection pressure lugs only.

**Units Without Disconnect Option**

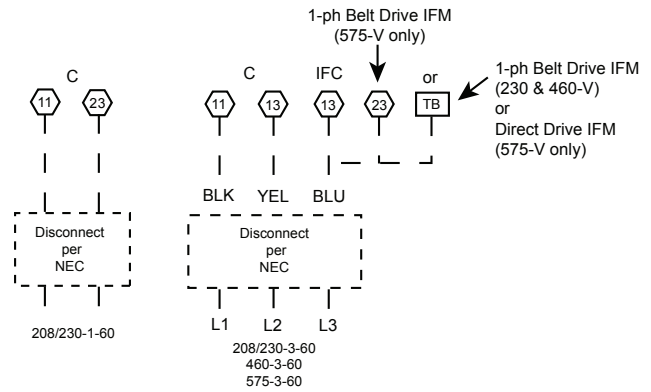

**Units With Disconnect Option**

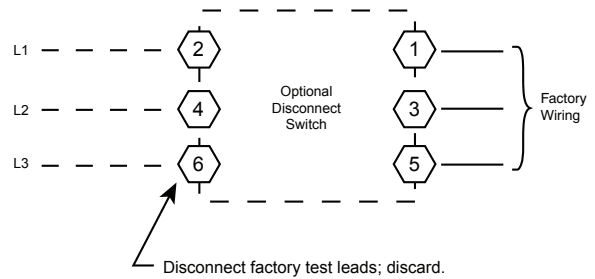

C11382

**Fig. 22 - Power Wiring Connections**

**⚠ WARNING**

**FIRE HAZARD**

Failure to follow this warning could result in intermittent operation or performance satisfaction.

Do not connect aluminum wire between disconnect switch and RGS unit. Use only copper wire. (See Fig. 23.)

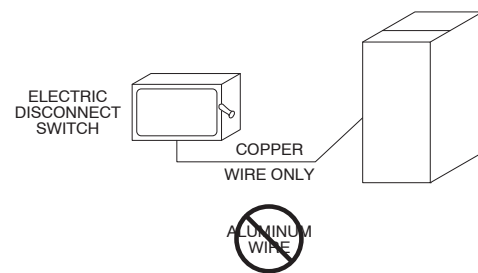

A93033

**Fig. 23 - Disconnect Switch and Unit**

**Units with Factory-Installed Non-Fused Disconnect —**

The factory-installed option non-fused disconnect (NFD) switch is located in a weatherproof enclosure located under the main control box. The manual switch handle and shaft are shipped in the disconnect enclosure. Assemble the shaft and handle to the switch at this point. Discard the factory test leads (see Fig. 22).

Connect field power supply conductors to LINE side terminals when the switch enclosure cover is removed to attach the handle.



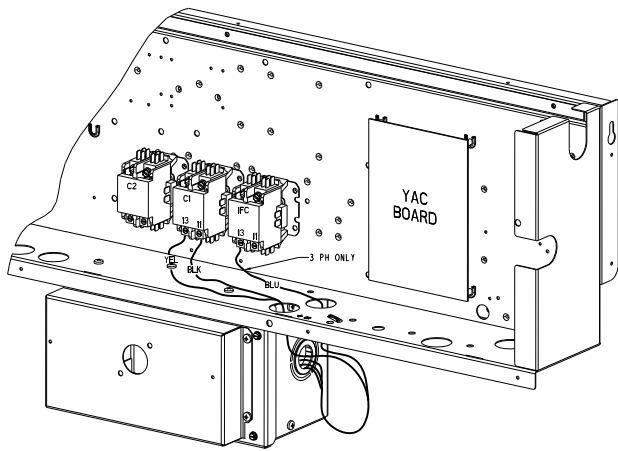

C12278

**Fig. 24 - Location of Non-Fused Disconnect Enclosure**

**To field install the NFD shaft and handle:**

1. Remove the unit front pane (see Fig. 1).
2. Remove (3) hex screws on the NFD enclosure - (2) on the face of the cover and (1) on the left side cover.
3. Remove the front cover of the NFD enclosure.
4. Make sure the NFD shipped from the factory is at OFF position (the arrow on the black handle knob is at OFF).
5. Insert the shaft with the cross pin on the top of the shaft in the horizontal position.
6. Measure from the tip of the shaft to the top surface of the black pointer; the measurement should be 3.75 - 3.88 in. (95 - 99 mm).
7. Tighten the locking screw to secure the shaft to the NFD.
8. Turn the handle to the OFF position with red arrow pointing at OFF.
9. Install the handle on to the painted cover horizontally with the red arrow pointing to the left.
10. Secure the handle to the painted cover with (2) screws and lock washers supplied.
11. Engaging the shaft into the handle socket, re-install (3) hex screws on the NFD enclosure.
12. Re-install the unit front panel.

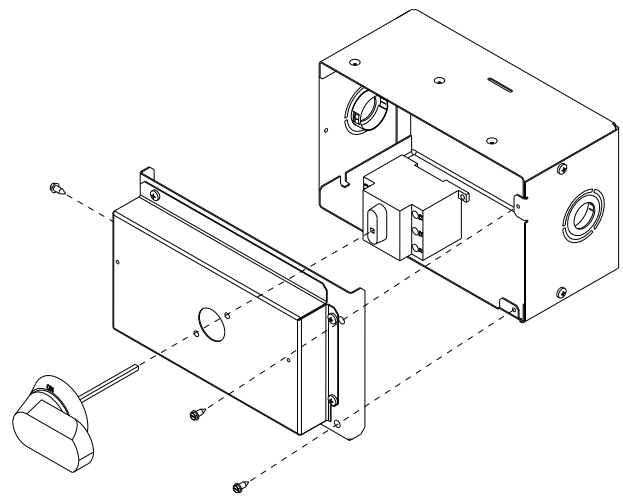

C12279

**Fig. 25 - Handle and Shaft Assembly for NFD**

**Units Without Factory-Installed Non-Fused Disconnect —**

When installing units, provide a disconnect switch per NEC (National Electrical Code) of adequate size. Disconnect sizing data is provided on the unit informative plate. Locate on unit cabinet or within sight of the unit per national or local codes. Do not cover unit informative plate if mounting the disconnect on the unit cabinet.

**All Units —**

All field wiring must comply with NEC and all local codes. Size wire based on MCA (Minimum Circuit Amps) on the unit informative plate. See Fig. 22 and the unit label diagram for power wiring connections to the unit power terminal blocks and equipment ground. Maximum wire size is #2 ga AWG (copper only) per pole on contactors.

Provide a ground-fault and short-circuit over-current protection device (fuse or breaker) per NEC Article 440 (or local codes). Refer to unit informative data plate for MOCP (Maximum Over-current Protection) device size.

All field wiring must comply with the NEC and local requirements.

All units except 208/230-v units are factory wired for the voltage shown on the nameplate. *If the 208/230-v unit is to be connected to a 208-v power supply, the control transformer must be rewired by moving the black wire with the 1/4-in. female spade connector from the 230-v connection and moving it to the 200-v 1/4-in. male terminal on the primary side of the transformer.* Refer to unit label diagram for additional information. Field power wires will be connected line-side pressure lugs on the power terminal block or at factory-installed option non-fused disconnect.

**NOTE:** Check all factory and field electrical connections for tightness.

**⚠ WARNING**

**ELECTRICAL OPERATION HAZARD**

Failure to follow this warning could result in personal injury or death.

Units with convenience outlet circuits may use multiple disconnects. Check convenience outlet for power status before opening unit for service. Locate its disconnect switch, if appropriate, and open it. Lock-out and tag-out this switch, if necessary.

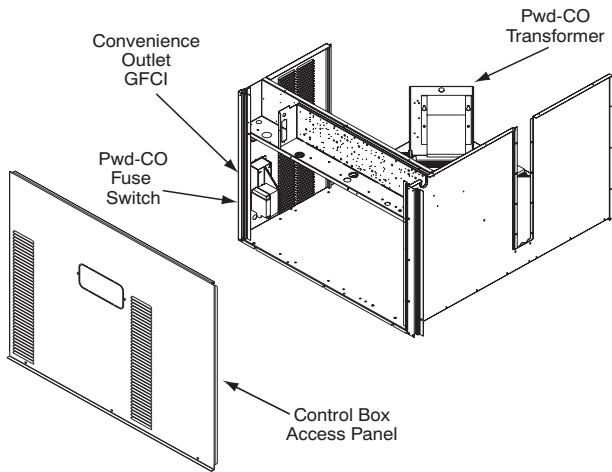

C08128

**Fig. 26 - Convenience Outlet Location**

**Non-powered Convenience Outlet:** These outlets require the field installation of a general-purpose 125-volt 15-A circuit powered from a source elsewhere in the building. Observe national and local codes when selecting wire size, fuse or breaker requirements and disconnect switch size and location. Route 125-v power supply conductors into the bottom of the utility box containing the duplex receptacle.

**Installing Weatherproof Cover:** A weatherproof while-in-use cover for the factory-installed convenience outlets is now required by UL standards. This cover cannot be factory-mounted due its depth; it must be installed at unit installation. For shipment, the convenience outlet is covered with a blank cover plate.

The weatherproof cover kit is shipped in the unit's control box. The kit includes the hinged cover, a backing plate and gasket.

**DISCONNECT ALL POWER TO UNIT AND CONVENIENCE OUTLET. LOCK-OUT AND TAG-OUT ALL POWER.**

Remove the blank cover plate at the convenience outlet; discard the blank cover.

Loosen the two screws at the GFCI duplex outlet, until approximately 1/2-in (13 mm) under screw heads are exposed. Press the gasket over the screw heads. Slip the backing plate over the screw heads at the keyhole slots and align with the gasket; tighten the two screws until snug (do not over-tighten).

Mount the weatherproof cover to the backing plate as shown in Fig. 27. Remove two slot fillers in the bottom of the cover to permit service tool cords to exit the cover. Check for full closing and latching.

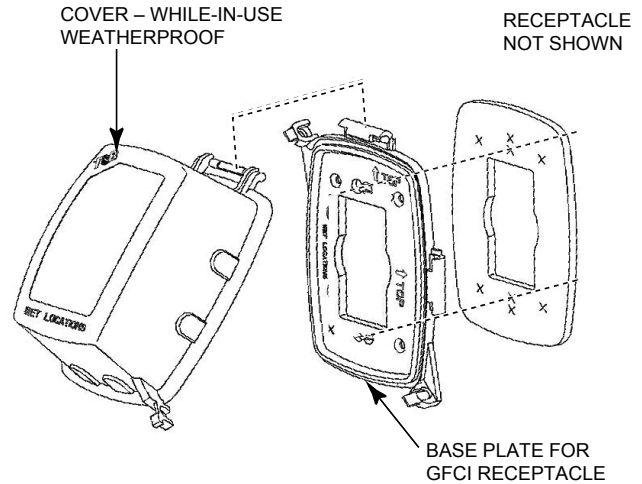

C09022

**Fig. 27 - Weatherproof Cover Installation**

Test the GFCI receptacle by pressing the TEST button on the face of the receptacle to trip and open the receptacle. Check for proper grounding wires and power line phasing if the GFCI receptacle does not trip as required. Press the RESET button to clear the tripped condition.

**Factory-Option Thru-Base Connections (Electrical Connections) —**

This service connection kit consists of a 1/2-in NPT gas adapter fitting (brass), a 1/2-in electrical bulkhead connector and a 3/4-in electrical bulkhead connector, all factory-installed in the embossed (raised) section of the unit basepan in the condenser section. The 3/4-in bulkhead connector enables the low-voltage control wires to pass through the basepan. The 1/2-in electrical bulkhead connector allows the high-voltage power wires to pass through the basepan. See Fig. 14.

Check tightness of connector lock nuts before connecting electrical conduits.

Field-supplied and field-installed liquid tight conduit connectors and conduit may be attached to the connectors on the basepan. Pull correctly rated high voltage and low voltage through appropriate conduits. Connect the power conduit to the internal disconnect (if unit is so equipped) or to the external disconnect (through unit side panel). A hole must be field cut in the main control box bottom on the left side so the 24-v control connections can be made. Connect the control power conduit to the unit control box at this hole.

**Units without Thru-Base Connections —**

1. Install power wiring conduit through side panel openings. Install conduit between disconnect and control box.
2. Install power lines to terminal connections as shown in Fig. 22.

Voltage to compressor terminals during operation must be within voltage range indicated on unit nameplate. See Table 6. On 3-phase units, voltages between phases must

be balanced within 2% and the current within 10%. Use the formula shown in the legend for Table 6, Note 2 to determine the percent of voltage imbalance. Operation on improper line voltage or excessive phase imbalance constitutes abuse and may cause damage to electrical components. Such operation would invalidate any applicable ICP warranty.

**Field Control Wiring —**

The RGS unit requires an external temperature control device. This device can be a thermostat emulation device provided as part of a third-party Building Management System.

**Thermostat —**

Install a approved accessory thermostat according to installation instructions included with the accessory. For complete economizer function, select a two-stage cooling thermostat. Locate the thermostat accessory on a solid wall in the conditioned space to sense average temperature in accordance with the thermostat installation instructions.

If the thermostat contains a logic circuit requiring 24-v power, use a thermostat cable or equivalent single leads of different colors with minimum of seven leads. If the thermostat does not require a 24-v source (no “C” connection required), use a thermostat cable or equivalent with minimum of six leads. Check the thermostat installation instructions for additional features which might require additional conductors in the cable.

For wire runs up to 50 ft. (15 m), use no. 18 AWG (American Wire Gage) insulated wire [35°C (95°F) minimum]. For 50 to 75 ft. (15 to 23 m), use no. 16 AWG insulated wire [35°C (95°F) minimum]. For over 75 ft. (23 m), use no. 14 AWG insulated wire [35°C (95°F) minimum]. All wire sizes larger than no. 18 AWG cannot be directly connected to the thermostat and will require a junction box and splice at the thermostat.

**Unit without Thru-Base Connection Kit —**

Pass the thermostat control wires through the hole provided in the corner post; then feed the wires through the raceway built into the corner post to the control box. Pull the wires over to the terminal strip on the upper-left corner of the Controls Connection Board. See Fig. 29.

**Heat Anticipator Settings —**

Set heat anticipator settings at 0.14 amp for the first stage and 0.14 amp for second-stage heating, when available.

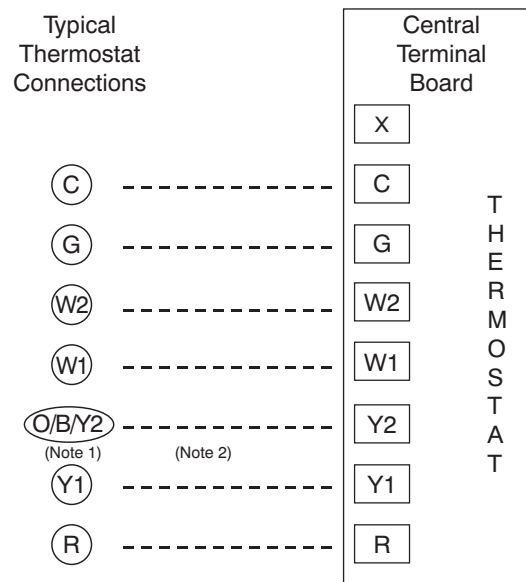

Note 1: Typical multi-function marking. Follow manufacturer's configuration Instructions to select Y2.

Note 2: Y2 to Y2 connection required on single-stage cooling units when integrated economizer function is desired.

--- Field Wiring

C08069

**Fig. 28 - Low-Voltage Connections**

**NOTE:** If thru-the-bottom connections accessory is used, refer to the accessory installation instructions for information on routing power and control wiring.

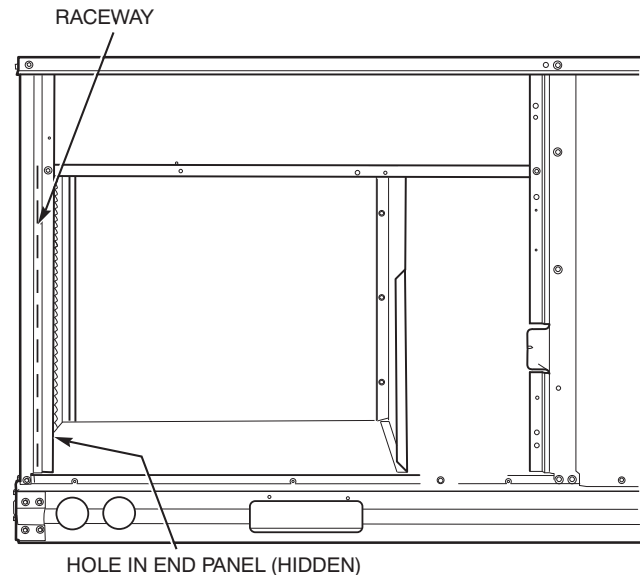

C08027

**Fig. 29 - Field Control Wiring Raceway**

**EconoMi\$er X (Factory-Installed Option)**

For details on operating RGS units equipped with the factory-installed EconoMi\$er X option, refer to *Factory-Installed Economizers for RGH/RAH/RHH/RGS/RAS/RHS Rooftop Units, 3 to 27.5 Nominal Tons. Economizer Supplement Related to California Title 24* (Literature number: 50901170301SS, or later).

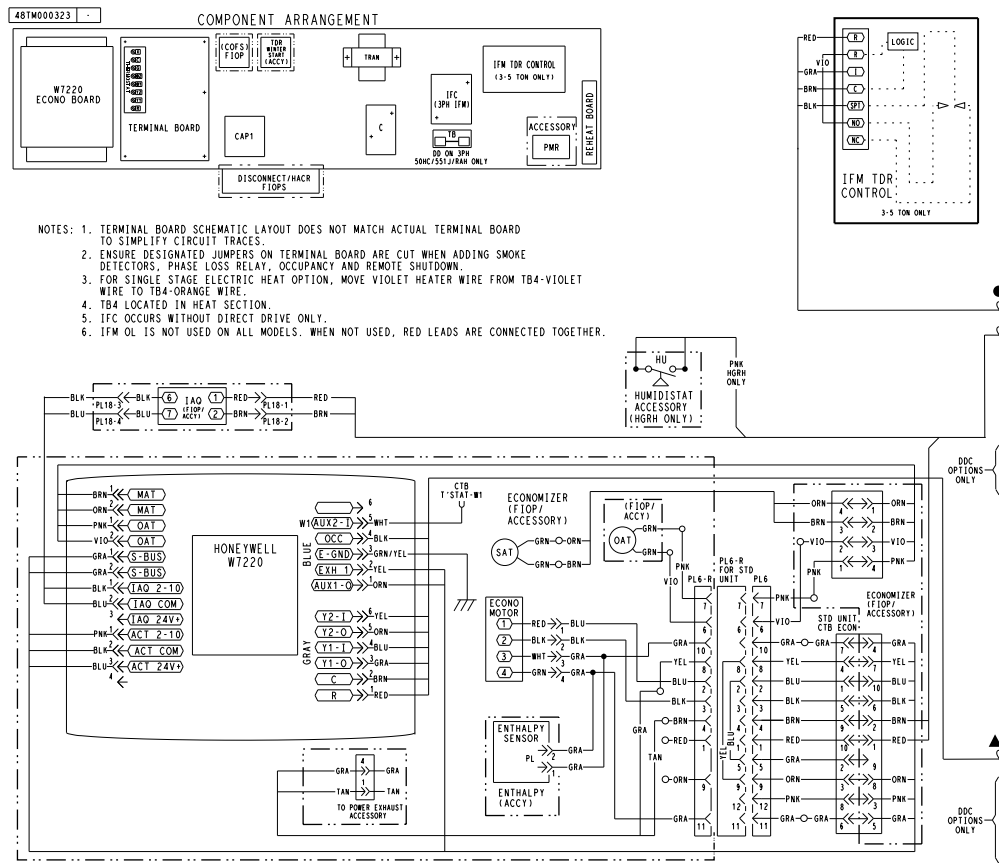

Fig. 30 - EconoMiSer X W720 Controller Wiring Diagram

C14225

## Hot Gas Re-Heat Control Connections

### Hot Gas Re-Heat - Space RH Controller —

**NOTE:** Hot Gas Re-Heat is a factory installed option which is available for 072 models only.

The Hot Gas Re-Heat dehumidification system requires a field-supplied and -installed space relative humidity control device. This device may be a separate humidistat control (contact closes on rise in space RH above control setpoint) or a combination thermostat-humidistat control device with isolated contact set for dehumidification control. The humidistat is normally used in applications where a temperature control is already provided.

#### To connect a field-supplied humidistat:

1. Route the humidistat 2-conductor cable (field-supplied) through the hole provided in the unit corner post.
2. Feed wires through the raceway built into the corner post (see Fig. 29) to the 24-v barrier located on the left side of the control box. The raceway provides the UL-required clearance between high-voltage and low-voltage wiring.
3. Use wire nuts to connect humidistat cable to two PINK leads in the low-voltage wiring as shown in Fig. 32.

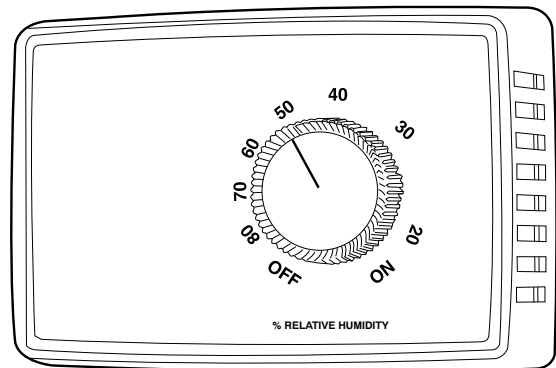

C092951

Fig. 31 - Accessory Field-Installed Humidistat

#### To connect the Thermidistat device:

1. Route the Thermostat multi-conductor thermostat cable (field-supplied) through the hole provided in the unit corner post.
2. Feed wires through the raceway built into the corner post (see Fig. 29) to the 24-v barrier located on the left side of the control box. The raceway provides the UL-required clearance between high-voltage and low-voltage wiring.
3. The Thermostat has dry contacts at terminals D1 and D2 for dehumidification operation (see Fig. 33). The dry contacts must be wired between CTB terminal R and the PINK lead to the LTLO switch with field-supplied wire nuts.

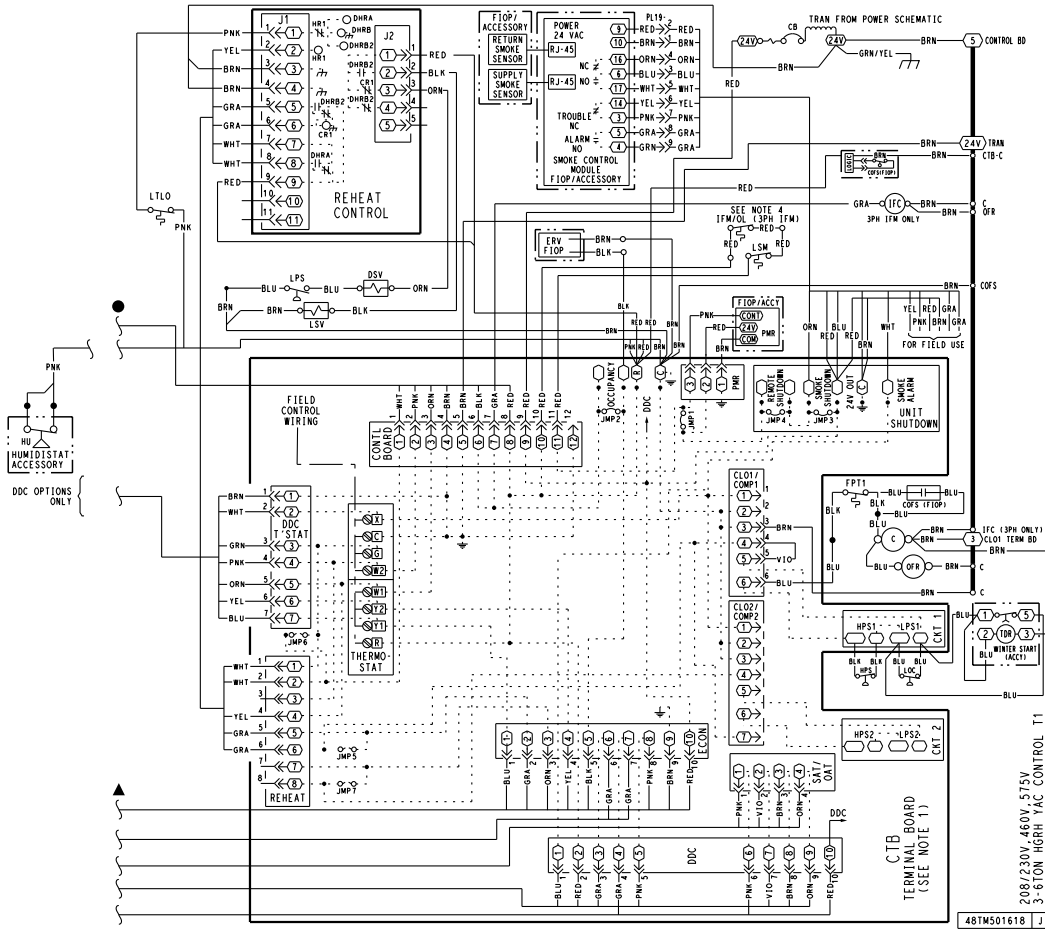
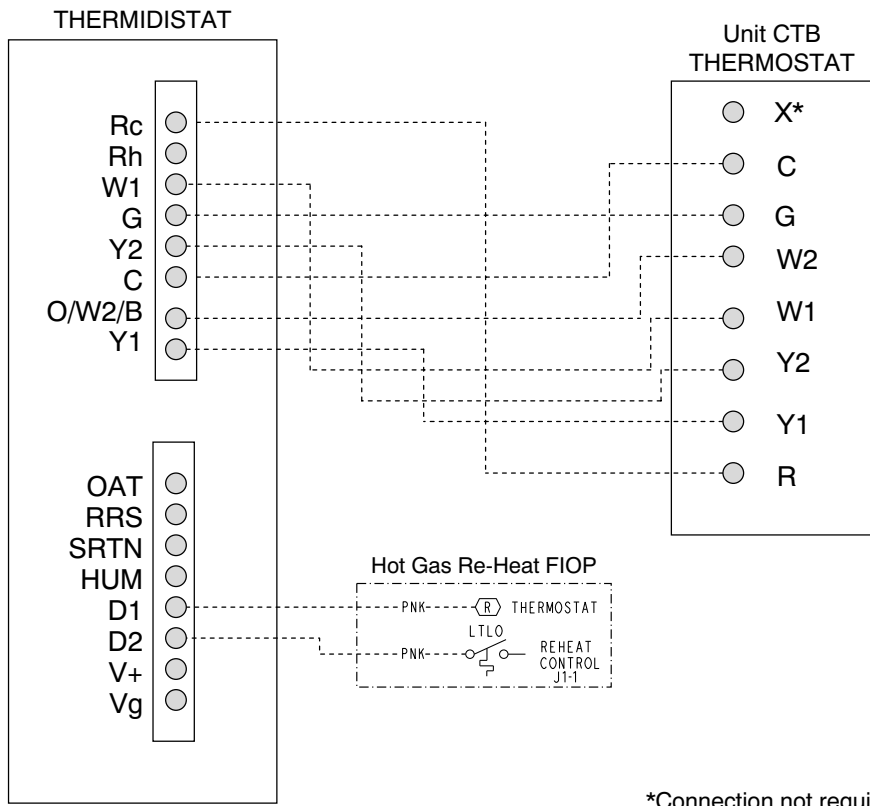

Fig. 32 - Humidistat Wiring - RGS072 with Hot Gas Re-Heat Dehumidification System

C150150



\*Connection not required.

Fig. 33 - Thermostat Device Connections for RGS072 with Hot Gas Re-Heat Dehumidification System

C092981

## **Smoke Detectors**

Smoke detectors are available as factory-installed options on RGS models. Smoke detectors may be specified for Supply Air only without or with economizer. All components necessary for operation are factory-provided and mounted. The unit is factory-configured for immediate smoke detector shutdown operation; additional wiring or modifications to unit terminal board may be necessary to complete the unit and smoke detector configuration to meet project requirements.

**Table 6 – Unit Wire/Fuse or HACR Breaker Sizing Data**

UNIT	NOM.V-Ph-Hz	IFM TYPE	NO C.O. or UNPWR C.O.								
			NO P.E.				w/ P.E. (pwrd fr/ unit)				
			MCA	MAX FUSE or HACR BRKR	DISC. SIZE		MCA	MAX FUSE or HACR BRKR	DISC. SIZE		
					FLA	LRA			FLA	LRA	
RGS036	208/230-1-60	STD	28	40	26	95	30	45	29	97	
		MED	28	40	26	95	30	45	29	97	
	208/230-3-60	DD-STD	21	30	21	83	23	30	23	85	
		STD	20	30	20	96	22	30	22	98	
		MED	20	30	20	96	22	30	22	98	
	460-3-60	HIGH	22/22	30/30	22/21	134	24/24	30/30	24/24	136	
		STD	11	15	11	49	12	15	12	50	
		MED	11	15	11	49	12	15	12	50	
	575-3-60	HIGH	12	15	12	68	13	15	13	69	
		STD	8	15	8	46	10	15	10	48	
		MED	8	15	8	46	10	15	10	48	
	RGS048	208/230-1-60	HIGH	8	15	7	50	10	15	10	52
STD			34	50	32	133	36	50	35	135	
208/230-3-60		MED	34	50	32	133	36	50	35	135	
		DD-STD	25	30	24	93	27	30	27	95	
460-3-60		STD	24	30	23	106	26	30	26	108	
		MED	24	30	23	106	26	30	26	108	
		HIGH	26/26	30/30	25/25	144	28/28	40/40	28/27	146	
575-3-60		STD	12	15	11	52	13	15	12	53	
		MED	12	15	11	52	13	15	12	53	
		HIGH	12	15	12	71	13	15	13	72	
RGS060		208/230-1-60	STD	9	15	9	42	11	15	11	44
			MED	9	15	9	42	11	15	11	44
	460-3-60	HIGH	9	15	9	46	11	15	11	48	
		STD	40	60	37	150	42	60	40	152	
		MED	42	60	40	175	44	60	42	177	
	208/230-3-60	DD-STD	29	40	28	122	31	45	31	124	
		STD	27	40	26	133	29	40	28	135	
		MED	28/28	40/40	28/27	171	30/30	45/45	30/30	173	
		HIGH	30/30	45/40	29/29	186	32/32	45/45	32/31	188	
	460-3-60	STD	13	20	13	63	14	20	14	64	
		MED	14	20	14	82	15	20	15	83	
		HIGH	15	20	15	90	16	20	16	91	
575-3-60	STD	11	15	10	48	13	15	12	50		
	MED	10	15	10	52	12	15	12	54		
	HIGH	11	15	11	63	13	15	13	65		

See "Legend and Notes for Table 6 on page 23.

**Table 6 - Unit Wire/Fuse or HACR Breaker Sizing Data (cont.)**

UNIT	NOM.V-Ph-Hz	IFM TYPE	NO C.O. or UNPWR C.O.							
			NO P.E.				w/ P.E. (pwrd fr/ unit)			
			MCA	MAX FUSE or HACR BRKR	DISC. SIZE		MCA	MAX FUSE or HACR BRKR	DISC. SIZE	
					FLA	LRA			FLA	LRA
<b>RGS072</b>  Units built on or after 02/09/2015	208/230-3-60	STD	33/33	50/50	32/32	197	35/35	50/50	34/34	199
		MED	35/35	50/50	34/34	212	37/37	50/50	36/36	214
		HIGH	37	50	36	226	39	50	39	228
	460-3-60	STD	15	20	14	96	16	20	15	97
		MED	16	20	15	104	17	20	16	105
		HIGH	17	20	16	111	18	25	18	112
	575-3-60	STD	11	15	11	68	13	15	13	70
		MED	12	15	12	79	14	20	14	81
		HIGH	12	15	12	79	14	20	14	81
<b>RGS072</b>  Units built on or prior to 02/08/2015	208/230-3-60	STD	33/32	50/50	32/31	184	35/34	50/50	34/33	186
		MED	34/34	50/50	33/33	199	36/36	50/50	35/35	201
		HIGH	36	50	36	213	38	50	38	215
	460-3-60	STD	17	25	16	92	18	25	17	93
		MED	18	25	17	100	19	25	18	101
		HIGH	19	25	18	107	20	25	19	108
	575-3-60	STD	12	15	12	63	14	20	14	65
		MED	13	20	12	74	15	20	15	76
		HIGH	13	20	12	74	15	20	15	76

**Legend and Notes for Table 6**

**LEGEND:**

- BRKR - Circuit breaker
- CO - Convenient outlet
- DD - Direct drive (indoor fan motor)
- DISC - Disconnect
- FLA - Full load amps
- IFM - Indoor fan motor
- LRA - Locked rotor amps
- MCA - Minimum circuit amps
- MOCP - MAX FUSE or HACR Breaker
- PE - Power exhaust
- PWRD CO - Powered convenient outlet
- UNPWR CO - Unpowered convenient outlet

**NOTES:**

- In compliance with NEC requirements for multimotor and combination load equipment (refer to NEC Articles 430 and 440), the overcurrent protective device for the unit shall be fuse or HACR breaker. Canadian units may be fuse or circuit breaker.

**2. Unbalanced 3-Phase Supply Voltage**

Never operate a motor where a phase imbalance in supply voltage is greater than 2%. Use the following formula to determine the percentage of voltage imbalance.

$$\% \text{ Voltage Imbalance} = 100 \times \frac{\text{max voltage deviation from average voltage}}{\text{average voltage}}$$

Example: Supply voltage is 230-3-60



- AB = 224 v
- BC = 231 v
- AC = 226 v

$$\text{Average Voltage} = \frac{(224 + 231 + 226)}{3} = \frac{681}{3} = 227$$

Determine maximum deviation from average voltage.

- (AB) 227 - 224 = 3 v
- (BC) 231 - 227 = 4 v
- (AC) 227 - 226 = 1 v

Maximum deviation is 4 v.

Determine percent of voltage imbalance.

$$\% \text{ Voltage Imbalance} = 100 \times \frac{4}{227} = 1.76\%$$

This amount of phase imbalance is satisfactory as it is below the maximum allowable 2%.

**IMPORTANT:** If the supply voltage phase imbalance is more than 2%, contact your local electric utility company immediately.



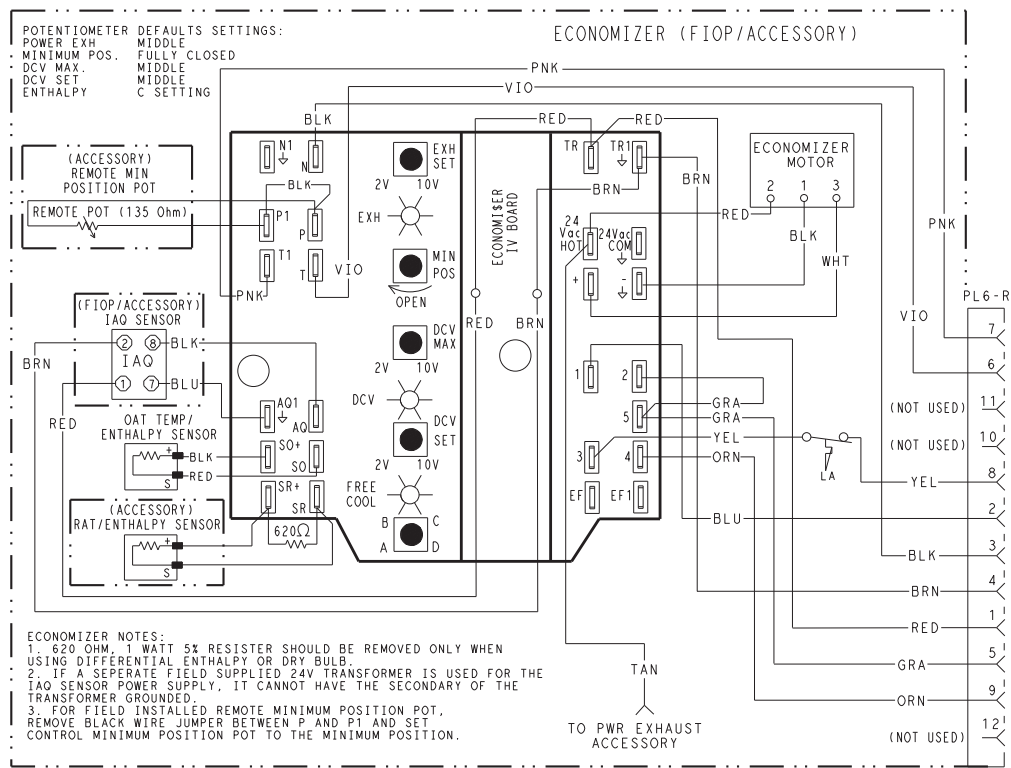

Fig. 34 - EconoMi\$er IV Wiring

C09302

### Step 13 — Adjust Factory-Installed Options

#### Smoke Detectors —

Smoke detector(s) will be connected at the Controls Connections Board, at terminals marked “Smoke Shutdown”. Cut jumper JMP 3 when ready to energize unit.

#### EconoMi\$er IV Occupancy Switch —

Refer to Fig. 34 for general EconoMi\$er IV wiring. External occupancy control is managed through a connection on the Controls Connections Board.

If external occupancy control is desired, connect a time clock or remotely controlled switch (closed for Occupied, open for Unoccupied sequence) at terminals marked OCCUPANCY. Cut jumper JMP 2 to complete the installation.

### Step 14 — Install Accessories

Available accessories include:

#### Curb

Thru-base connection kit (must be installed before unit is set on curb)

Electric heaters and single-point connection kits

Manual outside air damper

Two-Position motorized outside air damper

EconoMi\$er IV (with control)

Power Exhaust

CO<sub>2</sub> sensor

Louvered hail guard

Motormaster head pressure controls

Phase monitor control

Refer to separate installation instructions for information on installing these accessories.



# UNIT START-UP CHECKLIST

(Remove and Store in Job File)

MODEL NO.: \_\_\_\_\_

SERIAL NO.: \_\_\_\_\_

## I. PRE-START-UP

- VERIFY THAT ALL PACKAGING MATERIALS HAVE BEEN REMOVED FROM UNIT
- VERIFY INSTALLATION OF OUTDOOR AIR HOOD
- VERIFY INSTALLATION OF FLUE EXHAUST AND INLET HOOD
- VERIFY THAT CONDENSATE CONNECTION IS INSTALLED PER INSTRUCTIONS
- VERIFY THAT ALL ELECTRICAL CONNECTIONS AND TERMINALS ARE TIGHT
- VERIFY GAS PRESSURE TO UNIT GAS VALVE IS WITHIN SPECIFIED RANGE
- CHECK GAS PIPING FOR LEAKS
- CHECK THAT INDOOR-AIR FILTERS ARE CLEAN AND IN PLACE
- CHECK THAT OUTDOOR AIR INLET SCREENS ARE IN PLACE
- VERIFY THAT UNIT IS LEVEL
- CHECK FAN WHEELS AND PROPELLER FOR LOCATION IN HOUSING/ORIFICE AND VERIFY SETSCREW IS TIGHT
- VERIFY THAT FAN SHEAVES ARE ALIGNED AND BELTS ARE PROPERLY TENSIONED
- VERIFY THAT SCROLL COMPRESSORS ARE ROTATING IN THE CORRECT DIRECTION
- VERIFY INSTALLATION OF THERMOSTAT
- VERIFY THAT CRACKCASE HEATERS HAVE BEEN ENERGIZED FOR AT LEAST 24 HOURS

## II. START-UP

### ELECTRICAL

SUPPLY VOLTAGE	L1-L2 _____	L2-L3 _____	L3-L1 _____
COMPRESSOR AMPS 1	L1 _____	L2 _____	L3 _____
COMPRESSOR AMPS 2	L1 _____	L2 _____	L3 _____
SUPPLY FAN AMPS	L1 _____	L2 _____	L3 _____

### TEMPERATURES

OUTDOOR-AIR TEMPERATURE	_____ °F DB (DRY BULB)
RETURN-AIR TEMPERATURE	_____ °F DB _____ °F WB (WET BULB)
COOLING SUPPLY AIR TEMPERATURE	_____ °F
GAS HEAT SUPPLY AIR	_____ °F

### PRESSURES

GAS INLET PRESSURE	_____ IN. WG
GAS MANIFOLD PRESSURE STAGE 1	_____ IN. WG
STAGE 2	_____ IN. WG
REFRIGERANT SUCTION CIRCUIT A	_____ PSIG
CIRCUIT B	_____ PSIG
REFRIGERANT DISCHARGE CIRCUIT A	_____ PSIG
CIRCUIT B	_____ PSIG

- VERIFY REFRIGERANT CHARGE USING CHARGING CHARTS

### GENERAL

- ECONOMIZER MINIMUM VENT AND CHANGEOVER SETTINGS TO JOB REQUIREMENTS (IF EQUIPPED)
- VERIFY SMOKE DETECTOR UNIT SHUTDOWN BY UTILIZING MAGNET TEST

### III. HOT GAS RE-HEAT START-UP

#### STEPS

- 1. CHECK CTB FOR JUMPER 5, 6, 7  
JUMPER 5, 6, 7 MUST BE CUT AND OPEN
- 2. OPEN HUMIDISTAT CONTACTS
- 3. START UNIT IN COOLING (CLOSE Y1)

#### OBSERVE AND RECORD

- A. SUCTION PRESSURE \_\_\_\_\_ PSIG
  - B. DISCHARGE PRESSURE \_\_\_\_\_ PSIG
  - C. ENTERING AIR TEMPERATURE \_\_\_\_\_ °F
  - D. LIQUID LINE TEMPERATURE  
AT OUTLET OR REHEAT COIL \_\_\_\_\_ °F
  - E. CONFIRM CORRECT ROTATION FOR COMPRESSOR
  - F. CHECK FOR CORRECT RAMP-UP OF OUTDOOR FAN MOTOR AS CONDENSER COIL WARMS
- 4. CHECK UNIT CHARGE PER CHARGING CHART
  - 5. SWITCH UNIT TO HIGH-LATENT MODE (SUBCOOLER) BY CLOSING HUMIDISTAT WITH Y1 CLOSED

#### OBSERVE

- A. REDUCTION IN SUCTION PRESSURE (5 TO 7 PSI EXPECTED)
  - B. DISCHARGE PRESSURE UNCHANGED
  - C. LIQUID TEMPERATURE DROPS TO 50 TO 55°F RANGE
  - D. LSV SOLENOID ENERGIZED (VALVE CLOSSES)
- 6. SWITCH UNIT TO DEHUMID (REHEAT) BY OPENING Y1

#### OBSERVE

- A. SUCTION PRESSURE INCREASES TO NORMAL COOLING LEVEL
  - B. DISCHARGE PRESSURE DECREASES (35 TO 50 PSI)
  - C. LIQUID TEMPERATURE RETURNS TO NORMAL COOLING LEVEL
  - D. LSV SOLENOID ENERGIZED (VALVE CLOSSES)
  - E. DSV SOLENOID ENERGIZED, VALVE OPENS
- 7. WITH UNIT IN DEHUMID MODE CLOSE W1  
COMPRESSOR AND OUTDOOR FAN STOP; LSV AND DSV SOLENOIDS DE-ENERGIZED
  - 8. OPEN W1 RESTORE UNIT TO DEHUMID MODE
  - 9. OPEN HUMIDISTAT INPUT  
COMPRESSOR AND OUTDOOR FAN STOP; LSV AND DSV SOLENOIDS DE-ENERGIZED
  - 10. RESTORE SETPOINTS FOR THERMOSTAT AND HUMIDISTAT