



### 13 SEER PACKAGE GAS / ELECTRIC UNIT, 2½ to 5 TONS

#### 3-Phase, 208/230-3-60 and 460-3-60

#### REFRIGERATION CIRCUIT

- Environmentally sound R-410A refrigerant
- Scroll compressors standard on all models
- Copper tube/aluminum fin condenser and evaporator coils

#### EASY TO INSTALL AND SERVICE

- Installs easily on a rooftop or at ground level
- Easy single-panel accessibility for maintenance and installation
- Easily converts to down discharge applications
- Combination gas heating and electric cooling

#### BUILT TO LAST

- Wire grille
- NOx-approved units available
- Induced-draft combustion and venting
- Pre-painted steel cabinet
- Direct spark ignition
- PSC indoor blower motor on all models
- Aluminized steel tubular heat exchanger
- Vertical condenser fan discharge
- Rust-proof base with integral sloping drain
- High and low pressure switches factory installed

#### WARRANTY

- 10-year heat exchanger limited warranty
- 5-year compressor limited warranty
- 1-year parts limited warranty



As an Energy Star® Partner, International Comfort Products has determined that this product meets the ENERGY STAR® guidelines for energy efficiency.



#### UNIT PERFORMANCE DATA

Model Number	Voltage 3-phase 60 HZ	COOLING				HEATING		Unit Dimensions H x W x D Inches / mm	Operating Weight lbs / kg
		Nominal Capacity BTU/h	SEER	EER	S/T Ratio	Input BTU/h	Efficiency AFUE %		
PGD330040H0*A	208/230	28,000	13.2	11.2	.75	40,000	80.1	39x48x33 / 991x1226x831	313 / 142
PGD330060H0*A	208/230	28,000	13.2	11.2	.75	60,000	78.4	39x48x33 / 991x1226x831	313 / 142
PGD336060H0*A	208/230	34,000	13.5	11.2	.73	60,000	78.7	41x48x33 / 1042x1226x831	338 / 153
PGD336060L0*A	460	34,000	13.5	11.2	.73	60,000	78.7	41x48x33 / 1042x1226x831	338 / 153
PGD336090H0*A	208/230	34,000	13.5	11.2	.73	90,000	79.9	41x48x33 / 1042x1226x831	338 / 153
PGD336090L0*A	460	34,000	13.5	11.2	.73	90,000	79.9	41x48x33 / 1042x1226x831	338 / 153
PGD342060H0*A	208/230	40,000	13.0	10.9	.76	60,000	78.7	43x48x44 / 1042x1226x1123	401 / 182
PGD342060L0*A	460	40,000	13.0	10.9	.76	60,000	78.7	43x48x44 / 1042x1226x1123	401 / 182
PGD342090H0*A	208/230	40,000	13.0	10.9	.76	90,000	79.9	43x48x44 / 1042x1226x1123	401 / 182
PGD342090L0*A	460	40,000	13.0	10.9	.76	90,000	79.9	43x48x44 / 1042x1226x1123	401 / 182
PGD348090H0*A	208/230	46,500	13.2	10.9	.74	90,000	78.5	43x48x44 / 1193x1226x1123	418 / 190
PGD348090L0*A	460	46,500	13.2	10.9	.74	90,000	78.5	43x48x44 / 1042x1226x1123	418 / 190
PGD348115H0*A	208/230	46,500	13.2	10.9	.74	115,000	81.1/78.3**	43x48x44 / 1042x1226x1123	418 / 190
PGD348115L0*A	460	46,500	13.2	10.9	.74	115,000	81.1/78.3**	43x48x44 / 1042x1226x1123	418 / 190
PGD348130H0*A	208/230	46,500	13.2	10.9	.74	130,000	80.3	43x48x44 / 1042x1226x1123	418 / 190
PGD348130L0*A	460	46,500	13.2	10.9	.74	130,000	80.3	43x48x44 / 1042x1226x1123	418 / 190
PGD360090H0*A	208/230	56,500	13.2	11.0	.74	90,000	78.6	47x48x44 / 1193x1226x1123	418 / 190
PGD360090L0*A	460	56,500	13.2	11.0	.74	90,000	78.6	47x48x44 / 1193x1226x1123	446 / 202
PGD360115H0*A	208/230	56,500	13.2	11.0	.74	115,000	81.1/78.3**	47x48x44 / 1193x1226x1123	446 / 202
PGD360115L0*A	460	56,500	13.2	11.0	.74	115,000	81.1/78.3**	47x48x44 / 1193x1226x1123	446 / 202
PGD360130H0*A	208/230	56,500	13.2	11.0	.74	130,000	80.3	47x48x44 / 1193x1226x1123	446 / 202
PGD360130L0*A	460	56,500	13.2	11.0	.74	130,000	80.3	47x48x44 / 1193x1226x1123	446 / 202

\* 0 = Standard Model, 1 = Low NOx California Model

\*\* Standard Model = 81.1, Low NOx Model = 78.3

UNIT SPECIFICATIONS													
MODEL NUMBER	Electrical Data 3-phase, 60 HZ			Condenser									Sound Ratings (dBA)
				Coil			Fan Motor			Fan			
	Voltage	Maximum HACR Breaker or Fuse	MCA	Face Area (ft. <sup>2</sup> )	Fins Per Inch / Rows	Tube Diameter	Horse Power	Full Load Amps	Locked Rotor Amps	Diameter (inches)	RPM (Max)	CFM (Design)	
PGD330040H	208/230	25 amps	15.5	11.9	21 / 2	3/8"	1/8	0.9	1.6	22	825	2800	73
PGD330060H	208/230	15 amps	15.5										
PGD336060H	208/230	25 amps	16.5	13.6	21 / 2	3/8"	1/8	0.9	1.7	22	825	3000	76
PGD336060L	460	15 amps	9.5					0.6	0.9				
PGD336090H	208/230	25 amps	16.5					0.9	1.7				
PGD336090L	460	15 amps	9.5					0.6	0.9				
PGD342060H	208/230	30 amps	21.9	15.5	21 / 2	3/8"	1/8	0.9	1.7	22	825	3500	74
PGD342060L	460	15 amps	10.0					0.6	0.9				
PGD342090H	208/230	30 amps	21.9					0.9	1.7				
PGD342090L	460	15 amps	10.0					0.6	0.9				
PGD348090H	208/230	35 amps	22.9	15.5	21 / 2	3/8"	1/4	1.5	3.2	22	1100	3500	79
PGD348090L	460	15 amps	10.5					0.8	1.9				
PGD348115H	208/230	35 amps	22.9					1.5	3.2				
PGD348115L	460	15 amps	10.5					0.8	1.9				
PGD348130H	208/230	35 amps	22.9					1.5	3.2				
PGD348130L	460	15 amps	10.5					0.8	1.9				
PGD360090H	208/230	40 amps	29.8	19.4	21 / 2	3/8"	1/4	1.5	3.2	22	1100	4200	78
PGD360090L	460	20 amps	13.3					0.9	2.0				
PGD360115H	208/230	40 amps	29.8					1.5	3.2				
PGD360115L	460	20 amps	13.3					0.9	2.0				
PGD360130H	208/230	40 amps	29.8					1.5	3.2				
PGD360130L	460	20 amps	13.3					0.9	2.0				

MODEL NUMBER	Evaporator								Scroll Compressor		Factory Refrigerant Charge R-410A (lbs)	Shipping Weight (lbs)
	Coil			Motor		Blower						
	Face Area (ft. <sup>2</sup> )	Fins Per Inch / Rows	Tube Diam. (inch)	HP	Full Load Amps	Size (inches)	RPM (Max)	CFM (Rated)	Rated Load Amps	Locked Rotor Amps		
PGD330040H	3.7	17 / 3	3/8	1/3	2.0	10 x 10	1050	1000	10.1	58.0	8.0	367
PGD330060H									9.2	71.0		
PGD336060H	3.7	17 / 4	3/8	1/2	4.1	10 x 10	1000	1200	9.2	71.0	9.2	392
PGD336060L									5.6	38.0		
PGD336090H									9.2	71.0		
PGD336090L									5.6	38.0		
PGD342060H	4.7	17 / 3	3/8	1/2	4.1	11 x 10	1075	1400	13.5	88.0	8.8	463
PGD342060L									6.0	44.0		
PGD342090H									13.5	88.0		
PGD342090L									6.0	44.0		
PGD348090H	5.7	17 / 3	3/8	1/2	4.1	11 x 10	1075	1600	13.8	83.1	9.0	480
PGD348090L									6.2	41.0		
PGD348115H									13.8	83.1		
PGD348115L									6.2	41.0		
PGD348130H	5.7	17 / 4	3/8	1.0	6.2	11 x 10	1040	1750	13.8	83.1	10.5	508
PGD348130L									6.2	41.0		
PGD360090H	5.7	17 / 4	3/8	1.0	6.2	11 x 10	1040	1750	17.7	110.0	10.5	508
PGD360090L									7.8	52.0		
PGD360115H									17.7	110.0		
PGD360115L									7.8	52.0		
PGD360130H									17.7	110.0		
PGD360130L									7.8	52.0		

PRESSURE SWITCHES		
Switch Type	Cut-out Pressure (PSIG)	Reset (automatic) Pressure (PSIG)
High	650 +/- 15	420 +/- 15
Loss of Charge (Low)	20 +/- 5	45 +/- 10

**UNIT AIRFLOW, Horizontal and Downflow Discharge, 230 Volts, Dry Coil**

Model	Heating Rise Range	Motor Speed	External Static Pressure (Inches Water Column)									
				0.1	0.2	0.3	0.4	0.5	0.6	0.7	0.8	0.9
PGD330040	20 - 50	Low	CFM	935	885	820	757	686	583	423	263	--
			Heating Rise °F	32	34	37	40	44	NA	NA	NA	NA
		Medium <sup>1</sup>	CFM	1195	1155	1100	1028	957	868	769	647	365
			Heating Rise °F	25	26	27	29	31	35	39	46	NA
		High	CFM	1484	1421	1368	1279	1185	1088	970	853	712
			Heating Rise °F	20	21	22	23	25	28	31	35	42
PGD330060	35 - 65	Low	CFM	935	885	820	757	686	583	423	263	--
			Heating Rise °F	48	51	55	59	NA	NA	NA	NA	NA
		Medium <sup>1</sup>	CFM	1195	1155	1100	1028	957	868	769	647	365
			Heating Rise °F	38	39	41	44	47	52	59	NA	NA
		High	CFM	1484	1421	1368	1279	1185	1088	970	853	712
			Heating Rise °F	NA	NA	NA	35	38	41	46	53	63
PGD336060	25 - 55	Low <sup>1</sup>	CFM	1242	1170	1089	994	917	837	702	570	442
			Heating Rise °F	36	38	41	45	49	54	NA	NA	NA
		Medium	CFM	1320	1244	1162	1081	1005	897	767	662	541
			Heating Rise °F	34	36	39	42	45	50	NA	NA	NA
		High	CFM	1362	1288	1205	1119	1033	933	826	714	580
			Heating Rise °F	33	35	37	40	44	48	54	NA	NA
PGD336090	40 - 70	Low <sup>1</sup>	CFM	1242	1170	1089	994	917	837	702	570	442
			Heating Rise °F	54	58	62	68	NA	NA	NA	NA	NA
		Medium	CFM	1320	1244	1162	1081	1005	897	767	662	541
			Heating Rise °F	51	54	58	62	67	NA	NA	NA	NA
		High	CFM	1362	1288	1205	1119	1033	933	826	714	580
			Heating Rise °F	50	52	56	60	65	NA	NA	NA	NA
PGD342060	25 - 55	Low <sup>1</sup>	CFM	1405	1370	1330	1283	1230	1171	1106	1034	957
			Heating Rise °F	32	33	34	35	37	38	41	44	47
		Medium	CFM	1593	1552	1505	1452	1394	1330	1260	1184	1102
			Heating Rise °F	28	29	30	31	32	34	36	38	41
		High	CFM	1764	1710	1652	1591	1525	1456	1383	1306	1225
			Heating Rise °F	26	26	27	28	30	31	33	34	37
PGD342090	40 - 70	Low <sup>1</sup>	CFM	1405	1370	1330	1283	1230	1171	1106	1034	957
			Heating Rise °F	48	49	51	53	55	58	61	65	NA
		Medium	CFM	1593	1552	1505	1452	1394	1330	1260	1184	1102
			Heating Rise °F	42	43	45	46	48	51	54	57	61
		High	CFM	1764	1710	1652	1591	1525	1456	1383	1306	1225
			Heating Rise °F	NA	NA	41	42	44	46	49	52	55
PGD348090	25 - 55	Low	CFM	1550	1530	1493	1461	1414	1361	1320	1250	1177
			Heating Rise °F	44	44	45	46	48	50	51	54	NA
		Medium <sup>1</sup>	CFM	1798	1771	1734	1687	1645	1595	1530	1449	1355
			Heating Rise °F	38	38	39	40	41	42	44	47	50
		High	CFM	2124	2071	2000	1944	1876	1811	1735	1647	1555
			Heating Rise °F	32	33	34	35	36	37	39	41	43
PGD348115	35 - 65	Low	CFM	1550	1530	1493	1461	1414	1361	1320	1250	1177
			Heating Rise °F	56	56	58	59	61	63	65	NA	NA
		Medium <sup>1</sup>	CFM	1798	1771	1734	1687	1645	1595	1530	1449	1355
			Heating Rise °F	48	49	50	51	52	54	56	60	64
		High	CFM	2124	2071	2000	1944	1876	1811	1735	1647	1555
			Heating Rise °F	41	42	43	44	46	48	50	52	55
PGD348130	40 - 70	Low	CFM	1550	1530	1493	1461	1414	1361	1320	1250	1177
			Heating Rise °F	63	64	65	67	69	NA	NA	NA	NA
		Medium <sup>1</sup>	CFM	1798	1771	1734	1687	1645	1595	1530	1449	1355
			Heating Rise °F	54	55	56	58	59	61	64	67	NA
		High	CFM	2124	2071	2000	1944	1876	1811	1735	1647	1555
			Heating Rise °F	46	47	49	50	52	54	56	59	63
PGD360090	25 - 55	Low <sup>1</sup>	CFM	2027	1960	1901	1821	1759	1693	1616	1513	1354
			Heating Rise °F	33	34	36	37	38	40	42	45	50
		Medium	CFM	2095	2026	1962	1887	1817	1748	1679	1583	1439
			Heating Rise °F	32	33	34	36	37	39	40	43	47
		High	CFM	2184	2109	2036	1963	1886	1812	1729	1647	1496
			Heating Rise °F	31	32	33	34	36	37	39	41	45

- refer to Notes at the end of the chart -

**UNIT AIRFLOW, Horizontal and Downflow Discharge, 230 Volts, Dry Coil**

Model	Heating Rise Range	Motor Speed	External Static Pressure (Inches Water Column)									
			0.1	0.2	0.3	0.4	0.5	0.6	0.7	0.8	0.9	
PGD360115	35 - 65	Low <sup>1</sup>	CFM	2027	1960	1901	1821	1759	1693	1616	1513	1354
			Heating Rise °F	43	44	45	47	49	51	53	57	64
		Medium	CFM	2095	2026	1962	1887	1817	1748	1679	1583	1439
			Heating Rise °F	41	43	44	46	47	49	51	54	60
		High	CFM	2184	2109	2036	1963	1886	1812	1729	1647	1496
			Heating Rise °F	39	41	42	44	46	48	50	52	58
PGD360130	40 - 70	Low <sup>1</sup>	CFM	2027	1960	1901	1821	1759	1693	1616	1513	1354
			Heating Rise °F	48	50	51	54	55	58	60	64	NA
		Medium	CFM	2095	2026	1962	1887	1817	1748	1679	1583	1439
			Heating Rise °F	47	48	50	52	54	56	58	62	68
		High	CFM	2184	2109	2036	1963	1886	1812	1729	1647	1496
			Heating Rise °F	45	46	48	50	52	54	56	59	65

\* Air delivery values are without air filter and are for dry coil (See Pressure Drop tables). Deduct field-supplied air filter pressure drop and wet coil pressure drop to obtain external static pressure available for ducting.

1. Factory-shipped heating/cooling speed

NA - Not allowed for heating speed

**FILTER PRESSURE DROP**

FILTER SIZE	CFM																		
	500	600	700	800	900	1000	1100	1200	1300	1400	1500	1600	1700	1800	1900	2000	2100	2200	2300
	Pressure Drop (inches water column)																		
20 x 24 x 1	—	—	—	—	0.09	0.1	0.11	0.13	0.14	0.15	0.16	—	—	—	—	—	—	—	—
24 x 30 x 1	—	—	—	—	—	—	—	0.07	0.08	0.09	0.1	0.11	0.12	0.13	0.14	0.15	0.16	0.17	0.18
24 x 36 x 1	—	—	—	—	—	—	—	0.06	0.07	0.07	0.08	0.09	0.09	0.10	0.11	0.12	0.13	0.14	0.14

Minimum Filter Requirements:

20 x 24 x 1 = PGD324, PGD330

24 x 30 x 1 = PGD336

20 x 36 x 1 = PGD342, PGD348, PGD360

**PGD330 COOLING PERFORMANCE**

EVAPORATOR AIR		CONDENSER ENTERING AIR TEMPERATURES °F (°C)																	
CFM BF	Ewb	75 (23.9)			85 (29.4)			95 (35)			105 (40.6)			115 (46.1)			125 (51.7)		
		Capacity BTU/h x 1000		Total System kW	Capacity BTU/h x 1000		Total System kW	Capacity BTU/h x 1000		Total System kW	Capacity BTU/h x 1000		Total System kW	Capacity BTU/h x 1000		Total System kW	Capacity BTU/h x 1000		Total System kW
		Total	Sens		Total	Sens		Total	Sens		Total	Sens		Total	Sens		Total	Sens	
875 0.009	57	27.63	27.63	2.04	26.49	26.49	2.25	25.27	25.27	2.49	23.94	23.94	2.74	22.50	22.50	3.01	20.94	20.94	3.31
	62	28.17	25.17	2.04	26.78	24.51	2.25	25.33	25.15	2.49	23.94	23.94	2.74	22.50	22.50	3.01	20.94	20.94	3.31
	63	28.67	20.21	2.04	27.24	19.59	2.25	25.71	18.94	2.49	24.08	18.25	2.74	22.34	17.53	3.01	20.49	16.76	3.30
	67	30.82	20.91	2.05	29.28	20.29	2.26	27.63	19.63	2.49	25.87	18.95	2.75	23.99	18.22	3.02	21.99	17.45	3.31
1000 0.013	57	28.69	28.69	2.09	27.47	27.47	2.31	26.16	26.16	2.54	24.74	24.74	2.79	23.21	23.21	3.07	21.54	21.54	3.36
	62	28.77	28.54	2.09	27.47	27.47	2.31	26.16	26.16	2.54	24.74	24.74	2.79	23.21	23.21	3.07	21.54	21.54	3.36
	63	29.16	21.52	2.09	27.67	20.88	2.31	26.07	20.22	2.54	24.38	19.51	2.79	22.58	18.77	3.07	20.68	17.98	3.36
	67	31.33	22.30	2.10	29.72	21.67	2.31	28.00	21.00	2.55	26.18	20.30	2.80	24.24	19.55	3.07	22.17	18.76	3.36
1125 0.019	57	29.57	29.57	2.15	28.28	28.28	2.36	26.88	26.88	2.59	25.39	25.39	2.85	23.77	23.77	3.12	22.01	22.01	3.42
	62	29.56	29.56	2.15	28.27	28.27	2.36	26.88	26.88	2.59	25.39	25.39	2.85	23.77	23.77	3.12	22.01	22.01	3.42
	63	29.52	22.77	2.15	27.98	22.13	2.36	26.34	21.44	2.59	24.60	20.72	2.85	22.76	19.95	3.12	20.82	19.11	3.41
	67	31.70	23.65	2.15	30.03	23.00	2.36	28.26	22.32	2.60	26.40	21.60	2.85	24.41	20.83	3.13	22.30	20.00	3.42
72	34.73	18.26	2.16	32.90	17.63	2.37	30.94	16.96	2.60	28.89	16.27	2.86	26.67	15.53	3.13	24.34	14.76	3.42	

**PGD336 COOLING PERFORMANCE**

EVAPORATOR AIR		CONDENSER ENTERING AIR TEMPERATURES °F (°C)																	
CFM BF	Ewb	75 (23.9)			85 (29.4)			95 (35)			105 (40.6)			115 (46.1)			125 (51.7)		
		Capacity BTU/h x 1000		Total System kW	Capacity BTU/h x 1000		Total System kW	Capacity BTU/h x 1000		Total System kW	Capacity BTU/h x 1000		Total System kW	Capacity BTU/h x 1000		Total System kW	Capacity BTU/h x 1000		Total System kW
		Total	Sens		Total	Sens		Total	Sens		Total	Sens		Total	Sens		Total	Sens	
1050 0.002	57	32.76	32.76	2.31	31.53	31.53	2.56	30.22	30.22	2.84	28.82	28.82	3.15	27.30	27.30	3.48	25.63	25.63	3.85
	62	33.56	29.11	2.31	32.01	28.44	2.56	30.39	27.73	2.84	28.82	28.82	3.15	27.30	27.30	3.48	25.63	25.63	3.85
	63	34.27	23.75	2.31	32.67	23.09	2.56	30.98	22.40	2.84	29.20	21.68	3.15	27.28	20.92	3.48	25.21	20.11	3.85
	67	36.87	24.54	2.31	35.16	23.89	2.57	33.36	23.20	2.85	31.45	22.49	3.15	29.40	21.73	3.49	27.19	20.92	3.85
1200 0.004	57	34.22	34.22	2.36	32.89	32.89	2.62	31.49	31.49	2.90	29.98	29.98	3.20	28.34	28.34	3.54	26.55	26.55	3.91
	62	34.37	31.46	2.36	32.89	32.89	2.62	31.49	31.49	2.90	29.98	29.98	3.20	28.34	28.34	3.54	26.55	26.55	3.91
	63	34.97	25.40	2.37	33.30	24.72	2.62	31.54	24.02	2.90	29.68	23.28	3.20	27.69	22.50	3.54	25.55	21.67	3.90
	67	37.61	26.29	2.37	35.82	25.62	2.62	34.00	24.93	2.90	31.94	24.19	3.21	29.81	23.42	3.54	27.53	22.59	3.91
1350 0.008	57	41.33	21.04	2.38	39.38	20.37	2.63	37.31	19.68	2.91	35.13	18.95	3.22	32.80	18.19	3.55	30.30	17.38	3.91
	62	35.44	35.44	2.42	34.03	34.03	2.68	32.53	32.53	2.95	30.93	30.93	3.26	29.20	29.20	3.60	27.30	27.30	3.96
	63	35.44	35.44	2.42	34.03	34.03	2.68	32.53	32.53	2.95	30.93	30.93	3.26	29.20	29.20	3.60	27.30	27.30	3.96
	67	38.16	27.99	2.43	36.31	27.31	2.68	34.36	26.60	2.96	32.30	25.85	3.27	30.11	25.06	3.60	27.77	24.21	3.96
72	41.91	22.10	2.44	39.89	21.42	2.69	37.74	20.71	2.97	35.48	19.98	3.27	33.09	19.21	3.61	30.51	18.39	3.97	

- refer to Legend, Notes, and Formulas at the end of the chart -

PGD342 COOLING PERFORMANCE																			
EVAPORATOR AIR		CONDENSER ENTERING AIR TEMPERATURES °F (°C)																	
CFM BF	Ewb	75 (23.9)			85 (29.4)			95 (35)			105 (40.6)			115 (46.1)			125 (51.7)		
		Capacity BTU/h x 1000		Total System kW	Capacity BTU/h x 1000		Total System kW	Capacity BTU/h x 1000		Total System kW	Capacity BTU/h x 1000		Total System kW	Capacity BTU/h x 1000		Total System kW	Capacity BTU/h x 1000		Total System kW
		Total	Sens		Total	Sens		Total	Sens		Total	Sens		Total	Sens		Total	Sens	
1225 0.011	57	39.26	39.26	2.88	37.63	37.63	3.20	35.88	35.88	3.55	34.00	34.00	3.94	31.96	31.96	4.35	29.76	29.76	4.80
	62	40.35	36.68	2.89	38.34	35.70	3.21	36.22	34.64	3.56	34.03	33.95	3.94	31.96	31.96	4.35	29.76	29.76	4.80
	63	41.07	29.58	2.90	39.00	28.64	3.22	36.79	27.65	3.56	34.46	26.62	3.94	31.99	25.54	4.35	29.39	24.41	4.79
	72	48.32	24.44	2.96	45.81	23.49	3.28	43.17	22.50	3.63	40.38	21.47	4.00	37.41	20.39	4.41	34.32	19.28	4.84
1400 0.016	57	40.77	40.77	2.97	39.02	39.02	3.29	37.13	37.13	3.64	35.10	35.10	4.02	32.92	32.92	4.44	30.58	30.58	4.88
	62	41.18	39.33	2.98	39.13	38.81	3.29	37.13	37.13	3.64	35.10	35.10	4.02	32.92	32.92	4.44	30.58	30.58	4.88
	63	41.80	31.43	2.98	39.62	30.46	3.30	37.31	29.45	3.64	34.89	28.39	4.02	32.32	27.28	4.43	29.64	26.11	4.87
	72	44.88	32.54	3.01	42.50	31.56	3.32	40.00	30.54	3.67	37.37	29.47	4.05	34.58	28.34	4.45	31.68	27.18	4.89
1575 0.023	57	49.11	25.59	3.05	46.48	24.62	3.36	43.73	23.62	3.71	40.83	22.57	4.08	37.75	21.47	4.49	34.56	20.35	4.92
	62	42.02	42.02	3.06	40.15	40.15	3.38	38.14	38.14	3.73	35.99	35.99	4.11	33.68	33.68	4.52	31.22	31.22	4.96
	63	42.02	42.02	3.06	40.14	40.14	3.38	38.14	38.14	3.73	35.99	35.99	4.11	33.68	33.68	4.52	31.22	31.22	4.96
	72	42.32	33.20	3.06	40.06	32.21	3.38	37.68	31.17	3.72	35.19	30.08	4.10	32.55	28.93	4.51	29.81	27.71	4.95
	67	45.41	34.43	3.09	42.95	33.43	3.40	40.37	32.39	3.75	37.66	31.29	4.12	34.80	30.13	4.53	31.84	28.92	4.97
	72	49.67	26.70	3.13	46.95	25.71	3.44	44.12	24.70	3.79	41.12	23.64	4.16	37.96	22.53	4.56	34.69	21.39	5.00

PGD348 COOLING PERFORMANCE																			
EVAPORATOR AIR		CONDENSER ENTERING AIR TEMPERATURES °F (°C)																	
CFM BF	Ewb	75 (23.9)			85 (29.4)			95 (35)			105 (40.6)			115 (46.1)			125 (51.7)		
		Capacity BTU/h x 1000		Total System kW	Capacity BTU/h x 1000		Total System kW	Capacity BTU/h x 1000		Total System kW	Capacity BTU/h x 1000		Total System kW	Capacity BTU/h x 1000		Total System kW	Capacity BTU/h x 1000		Total System kW
		Total	Sens		Total	Sens		Total	Sens		Total	Sens		Total	Sens		Total	Sens	
1400 0.009	57	46.24	46.24	3.34	44.25	44.25	3.75	42.10	42.10	4.20	39.79	39.79	4.69	37.27	37.27	5.21	34.57	34.57	5.77
	62	47.38	41.31	3.34	44.96	40.19	3.75	42.39	38.97	4.20	39.78	39.78	4.69	37.27	37.27	5.21	34.57	34.57	5.77
	63	48.22	33.26	3.35	45.72	32.19	3.76	43.06	31.05	4.20	40.24	29.86	4.69	37.23	28.61	5.21	34.06	27.31	5.77
	72	51.54	34.27	3.36	48.83	33.18	3.77	45.97	32.05	4.22	42.91	30.85	4.70	39.67	29.60	5.22	36.28	28.30	5.77
1600 0.014	57	56.08	27.21	3.37	53.10	26.13	3.78	49.97	25.02	4.23	46.62	23.85	4.71	43.09	22.63	5.23	39.41	21.38	5.78
	62	47.90	47.90	3.43	45.77	45.77	3.84	43.47	43.47	4.29	40.98	40.98	4.77	38.30	38.30	5.29	35.44	35.44	5.85
	63	48.26	44.29	3.43	45.80	45.74	3.84	43.46	43.46	4.29	40.98	40.98	4.77	38.30	38.30	5.29	35.44	35.44	5.85
	72	48.98	35.32	3.43	46.37	34.22	3.84	43.61	33.07	4.29	40.67	31.85	4.77	37.56	30.57	5.29	34.30	29.23	5.85
1800 0.020	57	52.30	36.46	3.44	49.48	35.36	3.85	46.50	34.20	4.30	43.33	32.98	4.78	39.99	31.70	5.30	36.50	30.37	5.86
	62	56.88	28.48	3.46	53.77	27.39	3.87	50.52	26.26	4.31	47.05	25.07	4.79	43.40	23.84	5.31	39.62	22.58	5.86
	63	49.26	49.26	3.51	46.99	46.99	3.93	44.56	44.56	4.37	41.93	41.93	4.86	39.11	39.11	5.38	36.11	36.11	5.94
	72	49.26	49.26	3.51	46.99	46.99	3.93	44.56	44.56	4.37	41.93	41.93	4.86	39.11	39.11	5.38	36.11	36.11	5.94
	62	49.52	37.31	3.52	46.82	36.18	3.93	43.98	35.00	4.37	40.96	33.76	4.86	37.78	32.44	5.38	34.46	31.03	5.93
	67	52.84	38.59	3.53	49.92	37.46	3.94	46.86	36.28	4.38	43.60	35.04	4.87	40.18	33.72	5.38	36.63	32.34	5.94
	72	57.43	29.71	3.54	54.22	28.61	3.95	50.88	27.47	4.40	47.31	26.27	4.88	43.58	25.03	5.39	39.71	23.76	5.94

– refer to Legend, Notes, and Formulas at the end of the chart –

PGD360 COOLING PERFORMANCE																			
EVAPORATOR AIR		CONDENSER ENTERING AIR TEMPERATURES °F (°C)																	
CFM BF	Ewb	75 (23.9)			85 (29.4)			95 (35)			105 (40.6)			115 (46.1)			125 (51.7)		
		Capacity BTU/h x 1000		Total System kW	Capacity BTU/h x 1000		Total System kW	Capacity BTU/h x 1000		Total System kW	Capacity BTU/h x 1000		Total System kW	Capacity BTU/h x 1000		Total System kW	Capacity BTU/h x 1000		Total System kW
		Total	Sens		Total	Sens		Total	Sens		Total	Sens		Total	Sens		Total	Sens	
1750 0.010	57	57.18	57.18	4.12	54.74	54.74	4.57	52.17	52.17	5.08	49.44	49.44	5.62	46.49	46.49	6.21	43.26	43.26	6.85
	62	58.24	53.17	4.13	55.28	51.82	4.58	52.26	51.82	5.08	49.44	49.44	5.62	46.49	46.49	6.21	43.26	43.26	6.85
	63	59.21	43.22	4.14	56.15	41.90	4.59	52.95	40.53	5.08	49.60	39.12	5.62	46.07	37.65	6.21	42.28	36.10	6.84
	67	63.23	44.50	4.18	59.93	43.17	4.63	56.50	41.81	5.13	52.90	40.40	5.67	49.09	38.93	6.25	45.01	37.38	6.87
2000 0.016	72	68.86	35.81	4.24	65.24	34.48	4.69	61.48	33.13	5.19	57.53	31.73	5.72	53.35	30.27	6.30	48.86	28.73	6.92
	57	59.38	59.38	4.25	56.75	56.75	4.70	53.98	53.98	5.21	51.04	51.04	5.75	47.89	47.89	6.34	44.43	44.43	6.97
	62	59.48	57.25	4.25	56.75	56.75	4.70	53.98	53.98	5.21	51.04	51.04	5.75	47.89	47.89	6.34	44.43	44.43	6.97
	63	60.17	46.05	4.25	56.97	44.70	4.70	53.64	43.31	5.20	50.17	41.87	5.74	46.52	40.37	6.32	42.63	38.78	6.95
2250 0.022	67	64.20	47.51	4.29	60.76	46.16	4.75	57.19	44.78	5.24	53.46	43.34	5.78	49.53	41.85	6.36	45.33	40.26	6.98
	72	69.84	37.64	4.35	66.07	36.31	4.81	62.17	34.94	5.30	58.07	33.52	5.84	53.75	32.04	6.41	49.12	30.48	7.03
	57	61.17	61.17	4.37	58.37	58.37	4.83	55.44	55.44	5.33	52.32	52.32	5.88	48.98	48.98	6.46	45.33	45.33	7.09
	62	61.16	61.16	4.37	58.37	58.37	4.83	55.43	55.43	5.33	52.32	52.32	5.88	48.98	48.98	6.46	45.33	45.33	7.09
2250 0.022	63	60.89	48.82	4.37	57.57	47.44	4.82	54.15	46.02	5.31	50.59	44.55	5.85	46.85	43.00	6.43	42.92	41.27	7.06
	67	64.91	50.45	4.41	61.36	49.08	4.86	57.69	47.67	5.36	53.86	46.21	5.89	49.84	44.67	6.47	45.58	43.00	7.09
	72	70.53	39.43	4.47	66.65	38.07	4.92	62.63	36.69	5.42	58.41	35.26	5.95	53.97	33.76	6.52	49.23	32.19	7.14

\* 63°F Ewb is at 75°F entering dry bulb – Tennessee Valley Authority [TVA] rating conditions; all others at 80°F entering dry bulb.

LEGEND: BF — Bypass Factor Ewb — Entering Wet Bulb kW — Total Unit Power Input SHC — Sensible Heat Capacity (x1000 Btu/h) TC — Total Capacity (x1000 Btu/h) (net)

NOTES:

1. Ratings are net; they account for the effects of the evaporator fan motor power and heat.
2. Direct interpolation is permissible. Do not extrapolate.
3. The following formulas may be used:

$$t_{Ldb} = t_{Edb} - \frac{\text{Sensible Capacity (BTU/h)}}{1.10 \times \text{cfm}}$$

$$h_{Lwb} = h_{Ewb} - \frac{\text{Total Capacity (BTU/h)}}{4.5 \times \text{cfm}}$$

Where:  $h_{Ewb}$  = Enthalpy of air entering evaporator coil

$t_{Lwb}$  = Wet bulb temperature corresponding to enthalpy of air leaving evaporator coil ( $h_{Lwb}$ )

4. The SHC is based on 80°F Edb temperature of air entering evaporator coil.  
 Below 80°F Edb, subtract (corr factor x cfm) from SHC.  
 Above 80°F Edb, add (corr factor x cfm) to SHC. Correction Factor =  $1.10 \times (1 + BF) \times (Edb + 80)$ .

# ACCESSORIES

## ROOF CURBS

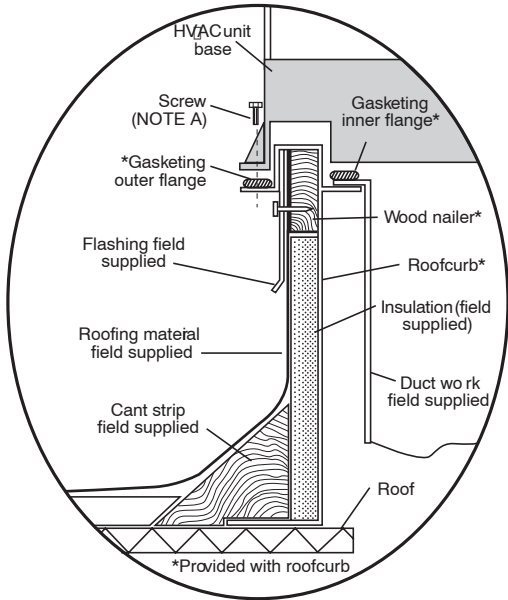

**Roof Curb for Small Cabinet**

Note A: When unit mounting screw is used, retainer bracket must also be used.

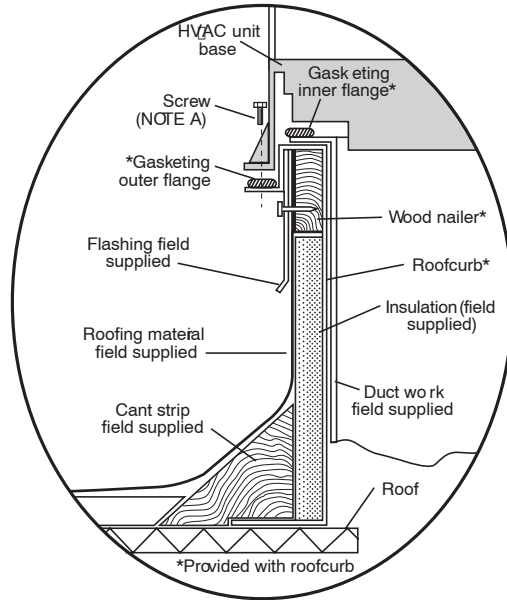

**Roof Curb for Large Cabinet**

Note A: When unit mounting screw is used, retainer bracket must also be used.

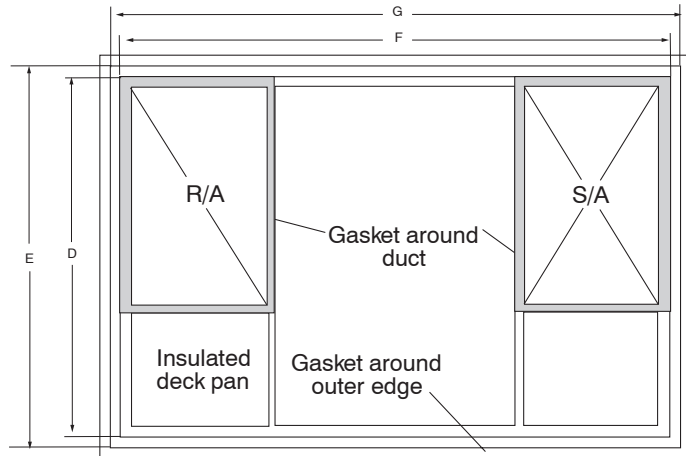
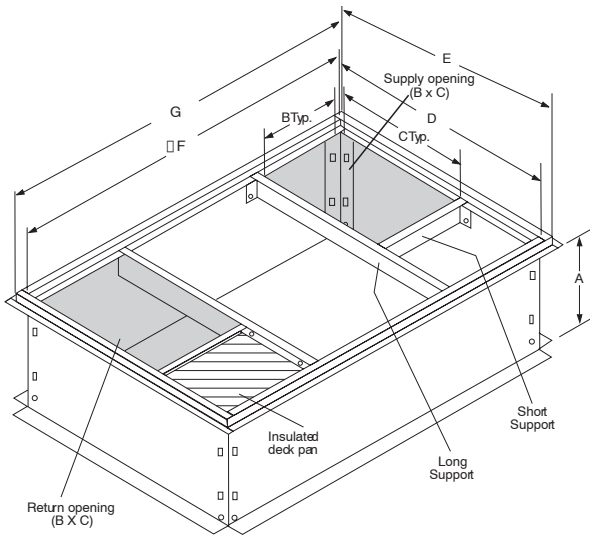

UNIT SIZE	MODEL NUMBER	A IN. [MM]	B IN. [MM]	C IN. [MM]	D IN. [MM]	E IN. [MM]	F IN. [MM]	G IN. [MM]
30, 36	NPRFCURB006A00	8 [203]	11 [279]	16-1/2 [419]	28-3/4 [730]	30-3/8 [771]	44-5/16 [1126]	45-15/16 [1167]
	NPRFCURB007A00	14 [356]	11 [279]	16-1/2 [419]	28-3/4 [730]	30-3/8 [771]	44-5/16 [1126]	45-15/16 [1167]
42, 48, 60	NPRFCURB008A00	8 [203]	16-3/16 [411]	17-3/8 [441]	40-1/4 [1022]	41-15/16 [1065]	44-7/16 [1129]	46-1/16 [1169]
	NPRFCURB009A00	14 [356]	16-3/16 [411]	17-3/8 [441]	40-1/4 [1022]	41-15/16 [1065]	44-7/16 [1129]	46-1/16 [1169]

**Notes:**

1. Seal strip must be applied as required to unit being installed.
2. Roof curb is made of 16 gauge steel.
3. Attach ductwork to curb (flanges of duct rest on curb).
4. Insulated panels: 1-in. thick fiberglass 1 lb. density.
5. When unit mounting screw is used (see Note A), a retainer bracket must be used as well. This bracket must also be used when required by code for hurricane or seismic conditions. This bracket is available through Micrometl.



**ACCESSORIES (continued)**

**ROOF CURBS**

Model Number	Description	Use With Model Size
NPRFCURB006A00	8" High Roof Curb	30, 36
NPRFCURB007A00	14" High Roof Curb	30, 36
NPRFCURB008A00	8" High Roof Curb	42, 48, 60
NPRFCURB009A00	14" High Roof Curb	42, 48, 60

**ECONOMIZERS**

Model Number	Description	Use With Model Size
NPECOMZR003A00	Vertical or Horizontal, internal with solid state controller, fully modulating damper, up to 50% barometric relief *, supply and dry bulb outdoor air sensors, filter rack with 1-inch filters.**	30, 36
NPECOMZR004A00		42
NPECOMZR006A00		48, 60
AXB078ENT	Outdoor Enthalpy Control	ALL

\* Barometric relief only works in the down discharge application

\*\* Outdoor enthalpy available as field installed accessory

**MANUAL FRESH AIR DAMPERS**

Model Number	Control	Use With Model Size
NPMANDPR004A00	Manual Outside Air Damper – External w/ filter rack and 1" filter	30, 36
NPMANDPR005A00		42
NPMANDPR006A00		48, 60

**FILTER RACK and FILTER (shipped with 1" filters)**

Model Number	Application	Filter Size	Use With Model Size
NPFILTRK004A00	Horizontal or Downflow Internal Filter Rack	12" x 20" x 1" (quan. 2) or 12" x 20" x 2" (quan. 1) <b>PLUS</b> 10" x 20" x 2" (quan.1)	30, 36
NPFILTRK005A00		12" x 24" x 1" or 2" (3 required)	42
NPFILTRK006A00		12" x 24" x 1" or 2" (3 required)	48, 60

**CONCENTRIC DIFFUSER & DUCT TRANSITIONS**

Model Number	Description	Use With Model Size
AXB030CSA	STEP DOWN – Fits 2' x 4' Ceiling Grid (Adpats round 18" duct)	ALL
AXB030CFA	FLUSH MOUNT – Fits 2' x 4' Ceiling Grid (Adapts round 18" duct)	ALL
NPDUCLG002A00	Square (14" x 16") to Round (14") – 1 set of 2, use with curb	30, 36, 42, 48

**HIGH AND LOW PRESSURE SWITCH KIT, LOW AMBIENT, ANTI-CYCLE TIMER, COMPRESSOR START ASSIST**

Model Number	Description	Use With Model Size
AXB035LAA	Low ambient Control – enables cooling system to operate down to 0 Deg. F by cycling condenser fan on and off	ALL
NRTIMEGD001A00	5 minute anti-cycle timer (Note: many thermostats have inherent anti-cycle timer logic)	ALL
NPHSTART001A00	PTC type compressor start assist	ALL

**GAS CONVERSION KITS**

Model Number	Description	Use With Model Size
NPLPCONV006A00	Natural Gas to Propane Conversion Kit (0 – 2000')	60K – 130K BTU/h
NPLPCONV007A00	Natural Gas to Propane Conversion Kit (2001 – 6000')	
NPLPCONV008A00	Natural Gas to Propane Conversion Kit (0 – 6000')	40 BTU/h
NPNGCONV001A00	Propane to Natural Gas Conversion Kit (0 – 2000')	ALL
NPHALTD012B06	Propane to Natural Gas Conversion Kit (2001 – 6000')	ALL

**CRANKCASE HEATER**

Model Number	Description	Use With Model Size
NPCRKHTR008A00	240V Belly-band type electric heater	30
NPCRKHTR004A00	240V Belly-band type electric heater	36, 42, 48
NPCRKHTR005A00	460V Belly-band type electric heater	42

**FLUE DISCHARGE DEFLECTOR**

Model Number	Description	Heat Input (BTU/h)	Use With Model Size
NRFLUEDS001A00	Directs flue gas exhaust 90 degrees upward from current discharge. Designed to allow tighter distances between unit and combustible surfaces. 24 inch Height. AGA certified.	40,000 – 130,000	ALL

**UNIT DIMENSIONS, model sizes 30, 36**

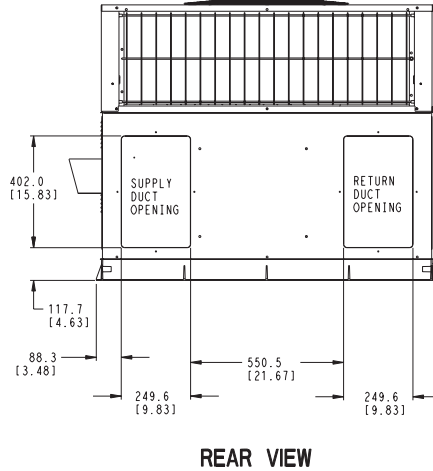
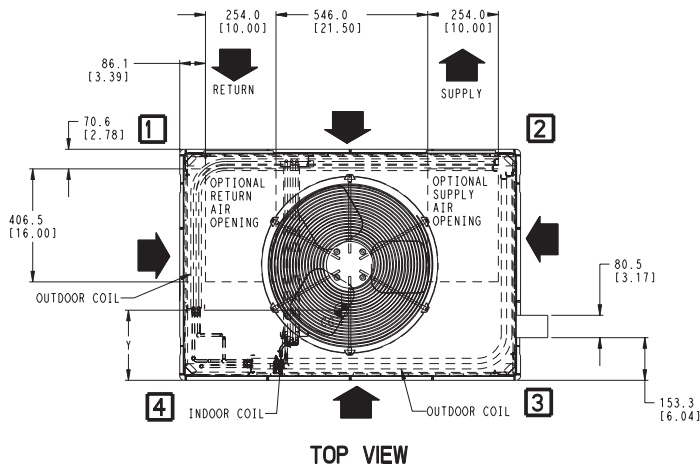

**REQUIRED CLEARANCES TO COMBUSTIBLE MATL.**

	MILLIMETERS [IN]
TOP OF UNIT.....	355.6 [14.00]
DUCT SIDE OF UNIT.....	50.8 [2.00]
SIDE OPPOSITE DUCTS.....	355.6 [14.00]
BOTTOM OF UNIT.....	12.7 [0.50]
FLUE PANEL.....	914.4 [36.00]

**NEC. REQUIRED CLEARANCES.**

	MILLIMETERS [IN]
BETWEEN UNITS, POWER ENTRY SIDE.....	1066.8 [42.00]
UNIT AND UNGROUNDED SURFACES, POWER ENTRY SIDE.....	914.0 [36.00]
UNIT AND BLOCK OR CONCRETE WALLS AND OTHER GROUNDED SURFACES, POWER ENTRY SIDE.....	1066.8 [42.00]

**REQUIRED CLEARANCE FOR OPERATION AND SERVICING**

	MILLIMETERS [IN]
EVAP. COIL ACCESS SIDE.....	914.0 [36.00]
POWER ENTRY SIDE.....	1066.8 [42.00]
(EXCEPT FOR NEC REQUIREMENTS)	
UNIT TOP.....	1219.2 [48.00]
SIDE OPPOSITE DUCTS.....	914.0 [36.00]
DUCT PANEL.....	304.8 [12.00]*

\*MINIMUM DISTANCES: IF UNIT IS PLACED LESS THAN 304.8 [12.00] FROM WALL SYSTEM, THEN SYSTEM PERFORMANCE MAYBE COMPROMISED.

DIMENSIONS IN [ ] ARE IN INCHES

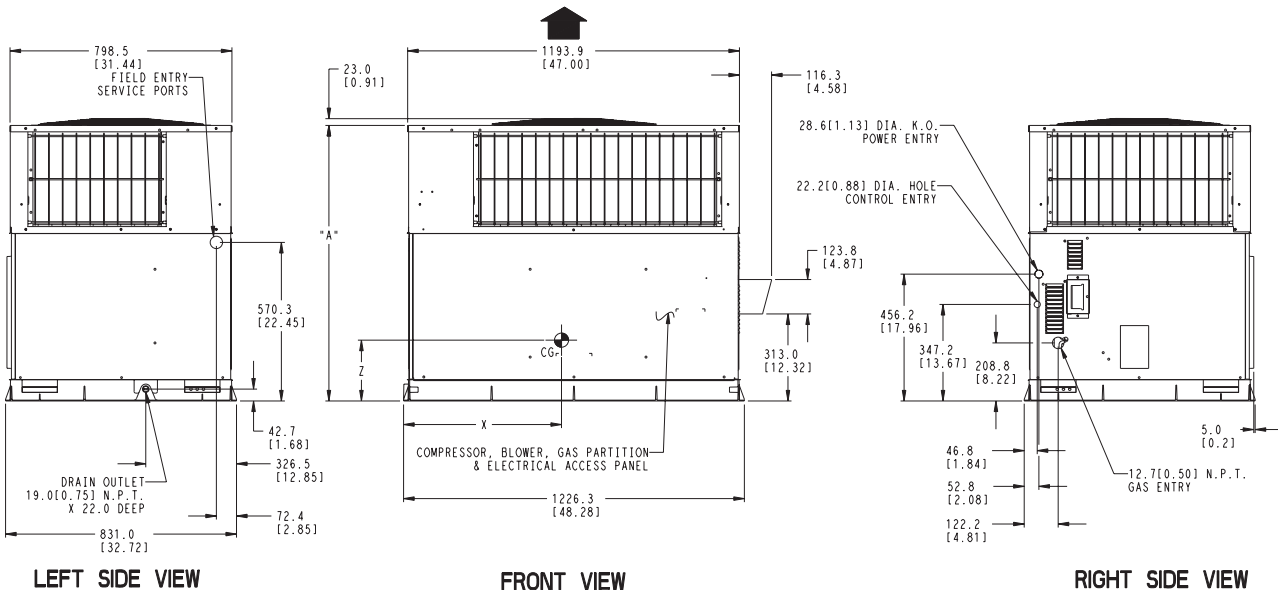

Model Size	UNIT HEIGHT inches [mm]	CENTER OF GRAVITY inches [mm]			
	A	X	Y	Z	
30	39.02 [991]	23.3 [591.8]	15.7 [398.8]	15.8 [401.3]	
36	41.02 [1042]	23.0 [584.2]	15.8 [401.3]	16.6 [421.6]	

**UNIT DIMENSIONS, model sizes 42, 48, 60**

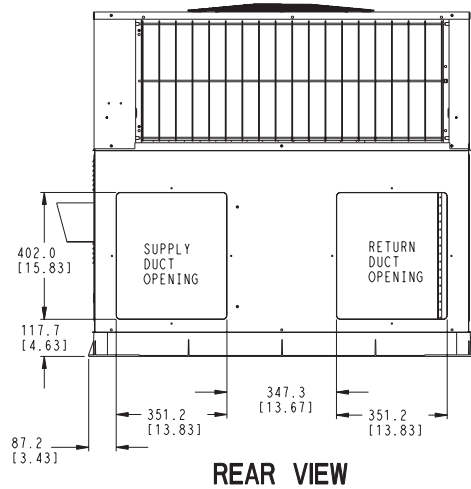
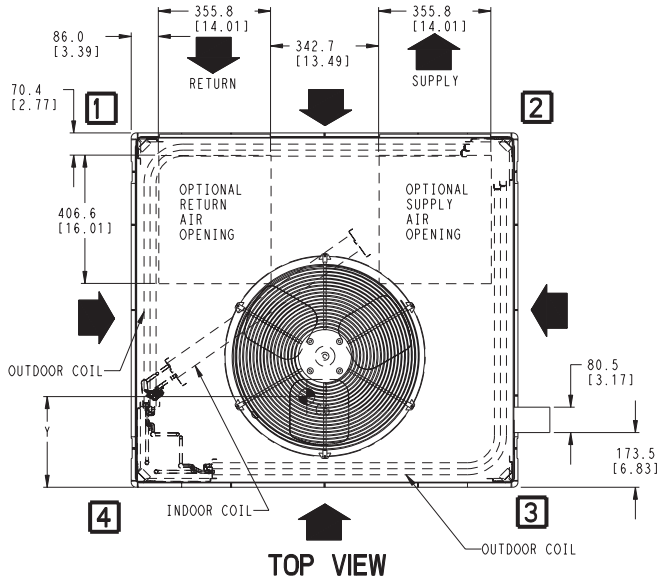

**REQUIRED CLEARANCES TO COMBUSTIBLE MATL.**

	MILLIMETERS [IN]
TOP OF UNIT.....	355.6 [14.00]
DUCT SIDE OF UNIT.....	50.8 [2.00]
SIDE OPPOSITE DUCTS.....	355.6 [14.00]
BOTTOM OF UNIT.....	12.7 [0.50]
FLUE PANEL.....	914.4 [36.00]

**NEC. REQUIRED CLEARANCES.**

	MILLIMETERS [IN]
BETWEEN UNITS, POWER ENTRY SIDE.....	1066.8 [42.00]
UNIT AND UNGROUNDED SURFACES, POWER ENTRY SIDE.....	914.0 [36.00]
UNIT AND BLOCK OR CONCRETE WALLS AND OTHER GROUNDED SURFACES, POWER ENTRY SIDE.....	1066.8 [42.00]

**REQUIRED CLEARANCE FOR OPERATION AND SERVICING**

	MILLIMETERS [IN]
EVAP. COIL ACCESS SIDE.....	914.0 [36.00]
POWER ENTRY SIDE.....	1066.8 [42.00]
(EXCEPT FOR NEC REQUIREMENTS)	
UNIT TOP.....	1219.2 [48.00]
SIDE OPPOSITE DUCTS.....	914.0 [36.00]
DUCT PANEL.....	304.8 [12.00]*

\*MINIMUM DISTANCES: IF UNIT IS PLACED LESS THAN 304.8 [12.00] FROM WALL SYSTEM, THEN SYSTEM PERFORMANCE MAYBE COMPROMISED.

DIMENSIONS IN [ ] ARE IN INCHES

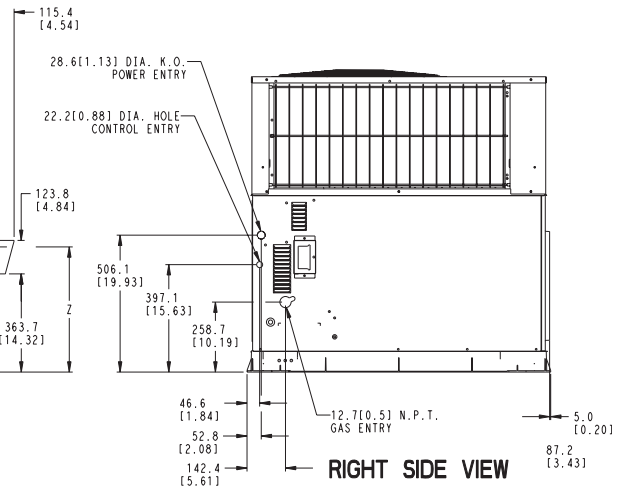
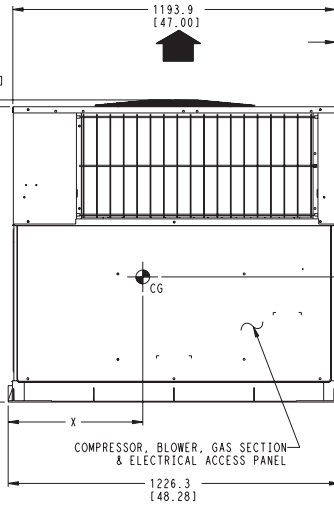
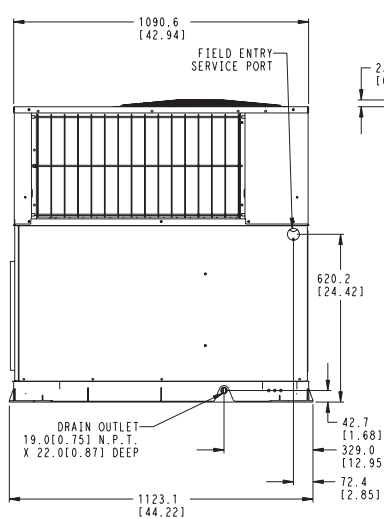

LEFT SIDE VIEW

FRONT VIEW

RIGHT SIDE VIEW

Model Size	UNIT HEIGHT inches [mm]		CENTER OF GRAVITY inches [mm]			
	A		X	Y	Z	
42	42.98 [1092]		25.5 [647.7]	20.5 [520.7]	17.1 [434.3]	
48	42.98 [1092]		25.2 [640.1]	20.7 [525.8]	17.4 [442.0]	
60	56.98 [1193]		25.5 [647.7]	21.0 [533.4]	17.6 [447.0]	

## GUIDE SPECIFICATIONS

### CABINET

Unit cabinet shall be constructed of phosphated, zinc-coated, pre-painted steel capable of with-standing 500 hours in salt spray. Normal service shall be through a single removable cabinet panel. The unit shall be constructed on a rust proof unit base that has an externally trapped, integrated sloped drain.

Evaporator fan compartment top surface shall be insulated with a minimum 1/2" thick, flexible fiberglass insulation, coated on the air side and retained by adhesive and mechanical means. The evaporator wall sections will be insulated with a minimum semi-rigid foil-faced board capable of being wiped clean. Aluminum foil-faced fiberglass insulation shall be used in the entire indoor air cavity section.

### COOLING SECTION

The unit is factory charged and operationally ready upon delivery. The unit refrigerant circuit has a high efficiency scroll compressor with internal overload protection, and copper tube / aluminum fin evaporator and condenser coils. The unit is designed for cooling operation to 40° F and will be capable of being wired for field installed economizer type accessories.

### COILS

The evaporator and condenser coils are fabricated with aluminum fins mechanically bonded to copper tubing. Both coils are pressure tested prior to assembly into the unit and electronically leak tested after assembly into the unit.

### CONDENSER FAN

The unit has a single direct-drive propeller-fan / motor assembly. The assembly is mounted directly to a vertical-discharge grille that is easily removed for service. Motors are 825 - 1100 RPM with sleeve or ball bearings and internal overload protection.

### EVAPORATOR BLOWER

All units have a PSC evaporator blower motor as a standard. The direct-drive evaporator blower motor has sleeve bearings and internal overload protection.

### HEATING SECTION

The gas-fired heating section features an induced draft blower for combustion air. The unit has an tubular aluminized steel heat exchanger located on the discharge air side of the blower. The system uses in-shot burners ignited by a direct spark ignition system, protected by both a high heat limit switch and flame roll-out switch. The induced draft blower motor is interlocked with a solid-state Hall-effect sensor safety device.

## CORNER WEIGHTS and RIGGING DETAILS

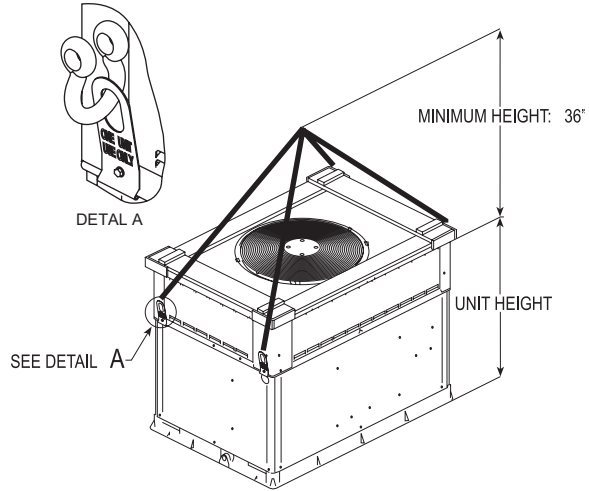
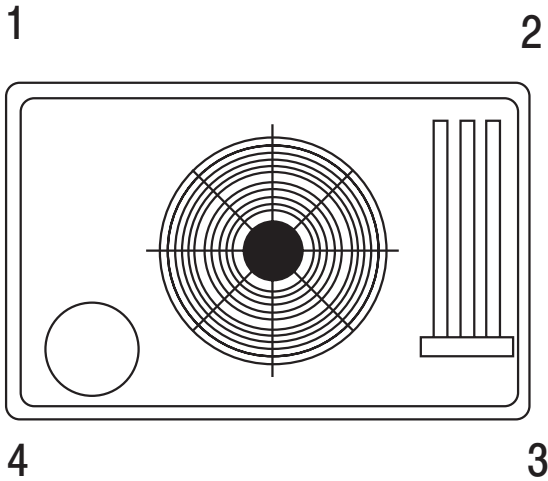

C00070b

A06361

CORNER WEIGHTS (SMALL CABINET)				
Model Size	30		36	
	lbs	kg	lbs	kg
Operating Weight	313	142.0	338	153.3
Corner Weight 1	55	25.1	72	32.5
Corner Weight 2	95	42.9	89	40.3
Corner Weight 3	78	35.2	95	43.0
Corner Weight 4	85	38.7	83	37.5
Rigging Weight	332	150.6	357	161.9
Shipping Weight	367	166.4	392	177.8

CORNER WEIGHTS (LARGE CABINET)						
Model Size	42		48		60	
	lbs	kg	lbs	kg	lbs	kg
Operating Weight	401	181.9	418	189.6	446	202.3
Corner Weight 1	68	30.6	62	28.1	54	24.5
Corner Weight 2	119	53.8	135	61.2	158	71.7
Corner Weight 3	60	27.2	64	29.2	81	36.6
Corner Weight 4	155	70.3	157	71.1	154	69.7
Shipping Weight	423	191.8	440	199.5	468	212.2
Shipping Weight	463	210.0	480	217.7	508	230.4

MODEL NOMENCLATURE										
<b>MODEL SERIES</b>	<b>P</b>	<b>G</b>	<b>D</b>	<b>3</b>	<b>36</b>	<b>060</b>	<b>H</b>	<b>00</b>	<b>A</b>	<b>1</b>
P = Package										
G = Gas/Electric										
D = R-410A										
3 = 13										
30 = 30,000 BTUH = 2.5 Tons										
36 = 36,000 BTUH = 3 Tons										
42 = 42,000 BTUH = 3.5 Tons										
48 = 48,000 BTUH = 4 Tons										
60 = 60,000 BTUH = 5 Tons										
040 = 40,000 BTUH										
060 = 60,000 BTUH										
090 = 90,000 BTUH										
115 = 115,000 BTUH										
130 = 130,000 BTUH										
H = 208/230-3-60										
L = 460-3-60										
00 = Standard										
01 = Low Nox										
Sales Model Digit										
Engineering Digit										