



14 SEER, 12 EER PACKAGE AIR CONDITIONER, 2 to 5 TONS

208/230-1-60 Single Phase

REFRIGERATION CIRCUIT

- Environmentally sound R-410A refrigerant
- Copper tube/aluminum fin condenser and evaporator coils
- Scroll compressor standard on all models
- Dehumidification mode (airflow reduction) on all models

EASY TO INSTALL AND SERVICE

- Installs easily on a rooftop or at ground level
- Easy three-panel accessibility for maintenance and installation
- Easily converts to down discharge applications

BUILT TO LAST

- Hail guard (3/8" spacing) wire grilles standard on PAD4**000KTP models (2" spacing wire grilles on non-tin models)
- Pre-painted steel cabinet
- High efficiency ECM indoor blower motor on all models
- Vertical condenser fan discharge
- Full perimeter steel base rails
- High and low pressure switches provide added reliability for the compressor
- All models available with optional factory installed tin-coated copper evaporator coil (These models are identified with letters TP in the 11th and 12th positions in the model number)

WARRANTY*

- 5 year No Hassle Replacement limited warranty for models with tin coated copper evaporator coils
- 5 year parts limited warranty (including compressor and coils)
 - With timely registration, an additional 5 year parts limited warranty (including compressor and coils)

*Applies to original purchaser/homeowner, some limitations may apply. See warranty certificate for complete details.



Use of the AHRI Certified TM Mark indicates a manufacturer's participation in the program. For verification of certification for individual products, go to www.ahridirectory.org.



As an Energy Star® Partner, International Comfort Products has determined that this product meets the ENERGY STAR® guidelines for energy efficiency.

UNIT PERFORMANCE DATA					
Model Number	COOLING			Unit Dimensions Height x Width x Depth in (mm)	Operating Weight lbs (kg)
	Capacity BTU/h	SEER	EER		
PAD424000K000C	23,600	14.5	12.0	40 x 48 ³ / ₁₆ x 32 ⁵ / ₈ (1016 x 1224 x 829)	288 (130)
PAD424000KTP0C	23,600	14.5	12.0	40 x 48 ³ / ₁₆ x 32 ⁵ / ₈ (1016 x 1224 x 829)	288 (130)
PAD430000K000C	28,600	14.5	12.0	40 x 48 ³ / ₁₆ x 32 ⁵ / ₈ (1016 x 1224 x 829)	300 (136)
PAD430000KTP0C	28,600	14.5	12.0	40 x 48 ³ / ₁₆ x 32 ⁵ / ₈ (1016 x 1224 x 829)	300 (136)
PAD436000K000C	34,200	14.5	12.0	46 x 48 ³ / ₁₆ x 32 ⁵ / ₈ (1168 x 1224 x 829)	358 (162)
PAD436000KTP0C	34,200	14.5	12.0	46 x 48 ³ / ₁₆ x 32 ⁵ / ₈ (1168 x 1224 x 829)	358 (162)
PAD442000K000C	41,000	14.5	12.0	49 ⁷ / ₈ x 48 ³ / ₁₆ x 44 ¹ / ₈ (1266 x 1224 x 1123)	412 (187)
PAD442000KTP0C	41,000	14.5	12.0	49 ⁷ / ₈ x 48 ³ / ₁₆ x 44 ¹ / ₈ (1266 x 1224 x 1123)	412 (187)
PAD448000K000C	47,000	14.2	12.0	49 ⁷ / ₈ x 48 ³ / ₁₆ x 44 ¹ / ₈ (1266 x 1224 x 1123)	430 (195)
PAD448000KTP0C	47,000	14.2	12.0	49 ⁷ / ₈ x 48 ³ / ₁₆ x 44 ¹ / ₈ (1266 x 1224 x 1123)	430 (195)
PAD460000K000C	57,000	14.2	12.0	53 ⁷ / ₈ x 48 ³ / ₁₆ x 44 ¹ / ₈ (1368 x 1224 x 1123)	458 (208)
PAD460000KTP0C	57,000	14.2	12.0	53 ⁷ / ₈ x 48 ³ / ₁₆ x 44 ¹ / ₈ (1368 x 1224 x 1123)	458 (208)

MODEL NOMENCLATURE											
MODEL SERIES	1	2	3	4	5,6	7,8,9	10	11,12	13	14	15
	P	A	D	4	36	000	K	00	0	C	1
P = Package											
A = Air Conditioner											
D = Standard											
3 = 13											
4 = 14											
5 = 15											
24 = 24,000 BTUH = 2 Tons											
30 = 30,000 BTUH = 2.5 Tons											
36 = 36,000 BTUH = 3 Tons											
42 = 42,000 BTUH = 3.5 Tons											
48 = 48,000 BTUH = 4 Tons											
60 = 60,000 BTUH = 5 Tons											
NOMINAL COOLING CAPACITY											
000 = no factory heat											
NOMINAL HEATING BTUH (input)											
K = 208/230-1-60											
VOLTAGE											
00 = No options											
TP = Tin Plated Evaporator Main Tubes											
FACTORY INSTALLED OPTIONS											
0 = Standard											
FEATURE CODE											
Sales Model Digit											
Engineering Digit											

AHRI* CAPACITIES

COOLING CAPACITIES AND EFFICIENCIES					
PAD4	NOMINAL TONS	STANDARD CFM	COOLING CAPACITY	EER	SEER
24	2	800	23600	12.0	14.5
30	2.5	1000	28600	12.0	14.5
36	3	1200	34200	12.0	14.5
42	3.5	1400	41000	12.0	14.5
48	4	1600	47000	12.0	14.2
60	5	1750	57000	12.0	14.2

LEGEND

dB—Sound Levels (decibels)

db—Dry Bulb

SEER—Seasonal Energy Efficiency Ratio

wb—Wet Bulb

COP—Coefficient of Performance

* Air Conditioning, Heating, & Refrigeration Institute.

**At "A" conditions—80°F (26.7°C) indoor db/67°F (19.4°C) indoor wb & 95°F (35°C) outdoor db.

† Rated in accordance with U.S. Government DOE Department of Energy) test procedures and/or ARI Standards 210/240-2008.

Notes:

1. Ratings are net values, reflecting the effects of circulating fan heat.

Ratings are based on:

Cooling Standard: 80°F (26.7°C) db, 67°Fwb (19.4°C) indoor entering—air temperature and 95°F db (35°C) outdoor entering—air temperature.

2. Before purchasing this appliance, read important energy cost and efficiency information available from your retailer.

ELECTRICAL DATA – PAD4

UNIT	NOMINAL	VOLTAGE RANGE		COMPRESSOR		OFM	IFM	ELECTRIC HEAT		POWER SUPPLY	
		MIN	MAX	RLA	LRA	FLA	FLA	NOMINAL kW	FLA	MCA	MOCP
								208v/230v	208v/230v	208v/230v	208v/230v
PAD424	208/230-1-60	197	253	13.5	58.3	0.7	4.1	-/-	-/-	21.7	30
								3.8/5	18.1/20.8	27.8/31.1	30/35
								5.4/7.2	25.9/30	37.5/42.6	40/45
								7.5/10	36.1/41.7	50.3/57.3	60/60
PAD430	208/230-1-60	197	253	12.8	64	0.7	4.1	-/-	-/-	20.8	30
								3.8/5	18.1/20.8	27.8/31.1	30/35
								5.4/7.2	25.9/30	37.5/42.6	40/45
								7.5/10	36.1/41.7	50.3/57.3	60/60
PAD436	208/230-1-60	197	253	14.1	77	1.2	6.0	-/-	-/-	24.8	35
								3.8/5	18.1/20.8	30.1/33.5	35/35
								5.4/7.2	25.9/30	39.9/45	40/45
								7.5/10	36.1/41.7	52.6/59.6	60/60
PAD442	208/230-1-60	197	253	17.9	112	1.2	6.0	-/-	-/-	29.6	40
								3.8/5	18.1/20.8	30.1/33.5	40/40
								5.4/7.2	25.9/30	39.9/45	40/45
								7.5/10	36.1/41.7	52.6/59.6	60/60
PAD448	208/230-1-60	197	253	21.8	117	1.2	7.6	-/-	-/-	36.1	50
								3.8/5	18.1/20.8	36.1/36.1	50/50
								5.4/7.2	25.9/30	41.9/47	50/50
								7.5/10	36.1/41.7	54.6/61.6	60/70
PAD460	208/230-1-60	197	253	26.4	134	1.2	7.6	-/-	-/-	41.8	60
								3.8/5	18.1/20.8	41.8/41.8	60/60
								5.4/7.2	25.9/30	41.9/47	60/60
								7.5/10	36.1/41.7	54.6/61.6	60/70
PAD460	208/230-1-60	197	253	26.4	134	1.2	7.6	11.3/15	54.2/62.5	77.3/87.6	80/90
								15/20	72.2/83.3	99.8/113.6	100/125

LEGEND

- FLA – Full Load Amps
- LRA – Locked Rotor Amps
- MCA – Minimum Circuit Amps
- MOCP – Maximum Overcurrent Protection
- RLA – Rated Load Amps

Notes:

1. In compliance with NEC (National Electrical Code) requirements for multimotor and combination load equipment (refer to NEC Articles 430 and 440), the overcurrent protective device for the unit shall be Power Supply fuse. The CGA (Canadian Gas Association) units may be fuse or circuit breaker.
2. Minimum wire size is based on 60°C copper wire. If other than 60°C wire is used, or if length exceeds wire length in table, determine size from NEC.



PHYSICAL DATA – UNIT PAD4						
UNIT SIZE	24	30	36	42	48	60
NOMINAL CAPACITY (ton)	2	2-1/2	3	3-1/2	4	5
SHIPPING WEIGHT lb.	295	307	365	421	439	467
SHIPPING WEIGHT (kg)	134	139	166	191	199	212
COMPRESSORS	Scroll					
Quantity	1					
REFRIGERANT (R-410A)						
Quantity lb	6.0	5.6	9.5	8.8	9.5	12.3
Quantity (kg)	2.7	2.5	4.3	4.0	4.3	5.6
REFRIGERANT METERING DEVICE	TXV					
OUTDOOR COIL						
Rows...Fins/in.	1...21	1...21	2...21	2...21	2...21	2...21
Face Area (sq ft)	11.9	13.6	15.4	13.6	17.5	21.4
OUTDOOR FAN						
Nominal Cfm	2500	2700	2800	3000	3200	3600
Diameter in.	24	24	24	26	26	26
Diameter (mm)	609.6	609.6	609.6	660.4	660.4	660.4
Motor HP (Rpm)	1/10 (810)	1/10 (810)	1/5 (810)	1/5 (810)	1/5 (810)	1/5 (810)
INDOOR COIL						
Rows...Fins/in.	3...17	3...17	3...17	3...17	3...17	3...17
Face Area (sq ft)	3.7	3.7	3.7	4.7	4.7	5.7
INDOOR BLOWER						
Nominal Cooling Airflow (Cfm)	800	1000	1200	1400	1600	1750
Size in.	10x10	10x10	11x10	11x10	11x10	11x10
Size (mm.)	254x254	254x254	279.4x254	279.4x254	279.4x254	279.4x254
Motor HP (RPM)	1/2 (1050)	1/2 (1050)	3/4 (1000)	3/4 (1075)	1.0 (1075)	1.0 (1040)
HIGH-PRESSURE SWITCH (psig) Cut-out Reset (Auto)	650 +/- 15 420 +/- 25					
LOSS-OF-CHARGE / LOW-PRESSURE SWITCH (Liquid Line) (psig) cut-out Reset (auto)	20 +/- 5 45 +/- 10					
RETURN-AIR FILTERS†‡						
Throwaway Size in.	20x20x1	20x24x1	24x30x1		24x36x1	
Throwaway Size (mm)	508x508x25	508x610x25	610x762x25		610x914x25	

† Required filter sizes shown are based on the larger of the AHRI (Air Conditioning, Heating, and Refrigeration Institute) rated cooling airflow or the heating airflow velocity of 300 ft/minute for throwaway type or 450 ft/minute for high-capacity type. Air filter pressure drop for non-standard filters must not exceed 0.08 in. W.C.

‡ If using accessory filter rack refer to the filter rack installation instructions for correct filter sizes and quantity.

A-WEIGHTED SOUND POWER LEVEL (dBA)								
MODEL PAD4	SOUND RATING	TYPICAL OCTAVE BAND SPECTRUM (without tone adjustment)						
		125	250	500	1000	2000	4000	8000
24	76	58.0	65.5	71.5	71.0	65.5	60.5	53.0
30	73	62.0	64.0	67.5	67.5	65.0	60.0	54.5
36	76	64.5	66.5	70.0	70.0	67.5	61.0	54.0
42	77	70.5	68.0	70.5	70.5	68.0	62.5	58.0
48	77	71.5	65.0	71.0	67.5	67.5	63.0	57.5
60	77	73.5	65.5	68.5	67.5	66.5	62.0	58.0

NOTE: Tested in accordance with AHRI Standard 270 (not listed in AHRI).

DRY COIL AIR DELIVERY* — HORIZONTAL DISCHARGE (CFM)												
UNIT	MOTOR SPEED	WIRE COLOR		EXTERNAL STATIC PRESSURE (IN. W.C.)								
				0.1	0.2	0.3	0.4	0.5	0.6	0.7	0.8	0.9
PAD424	Low	Blue	CFM	754	650	538	429	---	---	---	---	---
	Med-Low	Pink	CFM	851	777	675	591	475	---	---	---	---
	Medium ¹	Red	CFM	941	851	774	684	576	479	---	---	---
	Med-High	Orange	CFM	1009	917	840	759	667	577	447	---	---
	High	Black	CFM	1241	1167	1111	1036	969	881	818	731	640
PAD430	Low	Blue	CFM	741	638	547	415	---	---	---	---	---
	Med-Low	Pink	CFM	973	887	823	733	665	538	451	---	---
	Medium	Red	CFM	1088	1023	954	881	800	723	658	563	461
	Med-High ¹	Orange	CFM	1140	1064	996	915	840	758	687	564	480
	High	Black	CFM	1202	1140	1082	1015	961	881	810	732	631
PAD436	Low	Blue	CFM	1234	1168	1093	1021	961	894	825	759	687
	Med-Low	Pink	CFM	1290	1223	1154	1090	1027	977	894	828	762
	Medium ¹	Red	CFM	1354	1290	1226	1158	1102	1046	981	918	843
	Med-High	Orange	CFM	1606	1546	1489	1430	1371	1316	1258	1208	1140
	High	Black	CFM	1630	1580	1517	1463	1407	1339	1277	1210	1131
PAD442	Low	Blue	CFM	1295	1234	1182	1126	1075	1016	955	898	857
	Med-Low	Pink	CFM	1345	1282	1235	1194	1140	1095	1027	974	921
	Medium	Red	CFM	1505	1452	1413	1358	1323	1282	1234	1169	1130
	Med-High ¹	Orange	CFM	1545	1492	1449	1411	1362	1313	1278	1231	1188
	High	Black	CFM	1705	1643	1607	1568	1518	1483	1448	1404	1360
PAD448	Low	Blue	CFM	1402	1351	1311	1263	1224	1172	1136	1080	1041
	Med-Low	Pink	CFM	1457	1404	1367	1318	1284	1233	1197	1144	1104
	Medium ¹	Red	CFM	1736	1695	1642	1601	1553	1512	1465	1427	1381
	Med-High	Orange	CFM	2149	2111	2062	2026	1980	1945	1905	1864	1793
	High	Black	CFM	2344	2306	2259	2203	2141	2070	1991	1902	1803
PAD460	Med-Low	Pink	CFM	1678	1635	1602	1558	1513	1474	1438	1404	1349
	Medium ¹	Red	CFM	1962	1915	1880	1843	1794	1753	1711	1675	1628
	Med-High	Orange	CFM	2131	2088	2065	2013	1982	1941	1888	1860	1785
	High	Black	CFM	2461	2409	2339	2286	2192	2140	2062	1968	1874

* Air delivery values are without air filter and are for dry coil (See PAD4 Horizontal Wet Coil Pressure Drop table).

¹ Factory-shipped cooling speed

Note: For horizontal applications deduct field-supplied air filter pressure drop and wet coil pressure drop to obtain external static pressure available for ducting. For downflow applications see Wet Coil Air Delivery table for available static including wet coil, 1-in. filter and economizer.

Shaded areas indicate speed/static combinations that are not permitted for dehumidification speed.

HORIZONTAL WET COIL PRESSURE DROP (IN. W.C.)															
UNIT PAD4	STANDARD CFM (S.C.F.M)														
	600	700	800	900	1000	1100	1200	1300	1400	1500	1600	1700	1800	1900	2000
24	0.030	0.037	0.044	0.053	0.063	-	-	-	-	-	-	-	-	-	-
30	-	0.037	0.044	0.053	0.063	0.072	0.081	0.105	-	-	-	-	-	-	-
36	-	-	-	0.055	0.060	0.090	0.100	0.110	0.140	-	-	-	-	-	-
42	-	-	-	-	0.045	0.050	0.060	0.065	0.075	0.080	0.090	0.094	0.110	-	-
48	-	-	-	-	-	-	0.041	0.063	0.085	0.100	0.104	0.110	0.120	0.130	-
60	-	-	-	-	-	-	-	-	-	0.060	0.065	0.072	0.077	0.085	0.100

WET COIL AIR DELIVERY - DOWNFLOW - HIGH SPEED WITH 1-IN. (25 MM) FILTER AND ECONOMIZER											
UNIT PAD4	EXTERNAL STATIC PRESSURE (in. W.C.)										
	0.1	0.2	0.3	0.4	0.5	0.6	0.7	0.8	0.9	1.0	
36	1333	1289	1256	1214	1152	1118	1076	1035	997	950	
42	1612	1569	1527	1481	1451	1393	1351	1317	1278	1242	
48	2166	2085	2002	1919	1798	1709	1582	1467	1270	988	
60	2298	2239	2180	2110	2044	1951	1862	1777	1697	1591	

HORIZONTAL FILTER PRESSURE DROP TABLE (IN. W.C.)																			
FILTER SIZE in. (mm)	CFM																		
	500	600	700	800	900	1000	1100	1200	1300	1400	1500	1600	1700	1800	1900	2000	2100	2200	2300
20X20X1 (508X508X25)	0.05	0.07	0.08	0.1	0.12	0.13	0.14	0.15	---	---	---	---	---	---	---	---	---	---	
20X24X1 (508X610X25)	---	---	---	.09	.10	.11	.13	.14	.15	.16	---	---	---	---	---	---	---	---	
24X30X1 (610X762X25)	---	---	---	0.04	0.05	0.06	0.07	0.07	0.08	0.09	0.1	---	---	---	---	---	---	---	
24X36X1 (610X914X25)	---	---	---	---	---	---	---	0.06	0.07	0.07	0.08	0.09	0.09	0.10	0.11	0.12	0.13	0.14	0.14

ECONOMIZER 1-IN. (25 MM) FILTER PRESSURE DROP (IN. W.C.)	
UNIT PAD4	PRESSURE DROP
24-36	0.20
42-60	0.25

MULTIPLICATION FACTORS		
HEATER KW RATING	VOLTAGE DISTRIBUTION V/3/60	MULTIPLICATION FACTOR
240	200	0.69
	208	0.75
	230	0.92
	240	1.00

ELECTRIC HEAT PRESSURE DROP TABLES (in wc)

SMALL CABINET: PAD424-36												
STATIC	CFM											
	500	600	700	800	900	1000	1100	1200	1300	1400	1500	1600
5 kW	0.00	0.00	0.00	0.00	0.00	0.00	0.00	0.00	0.02	0.04	0.06	0.07
10 kW	0.00	0.00	0.00	0.00	0.00	0.02	0.04	0.06	0.08	0.10	0.12	0.14
15 kW	0.00	0.00	0.00	0.02	0.04	0.06	0.08	0.10	0.12	0.14	0.16	0.18
20 kW	0.00	0.00	0.02	0.04	0.06	0.08	0.09	0.11	0.13	0.15	0.17	0.19

LARGE CABINET: PAD442-60															
STATIC	CFM														
	1100	1200	1300	1400	1500	1600	1700	1800	1900	2000	2100	2200	2300	2400	2500
5 kW	0.00	0.00	0.00	0.01	0.02	0.03	0.04	0.05	0.06	0.07	0.08	0.09	0.10	0.11	0.12
10 kW	0.00	0.00	0.01	0.02	0.03	0.04	0.05	0.06	0.07	0.08	0.09	0.10	0.11	0.12	0.13
15 kW	0.00	0.02	0.03	0.04	0.05	0.06	0.07	0.08	0.09	0.10	0.11	0.12	0.13	0.14	0.15
20 kW	0.02	0.03	0.04	0.05	0.06	0.07	0.08	0.09	0.10	0.11	0.12	0.13	0.14	0.15	0.16

MINIMUM AIRFLOW FOR SAFE ELECTRIC HEATER OPERATION (CFM)						
SIZE	24	30	36	42	48	60
Cfm	800	1000	1200	1400	1600	1750

PAD424 COOLING EXTENDED PERFORMANCE TABLE

EVAPORATOR AIR		CONDENSER ENTERING AIR TEMPERATURES ° F (° C)																	
		75 (23.9)			85 (29.4)			95 (35)			105 (40.6)			115 (46.1)			125 (51.7)		
		CFM/BF	EWB ° F (° C)	Capacity MBtuh	Total Sys KW	Capacity MBtuh	Total Sys KW	Capacity MBtuh	Total Sys KW	Capacity MBtuh	Total Sys KW	Capacity MBtuh	Total Sys KW	Capacity MBtuh	Total Sys KW	Capacity MBtuh	Total Sys KW		
700/0.02	57(13.8)	22.98	22.98	1.47	21.68	21.68	1.68	20.31	20.31	1.90	18.78	18.78	2.14	17.08	17.08	2.40	15.36	15.36	2.68
	62(16.6)	23.82	21.37	1.48	22.23	20.56	1.68	20.58	19.70	1.91	18.81	18.81	2.14	17.11	17.11	2.40	15.39	15.39	2.68
	63*(17.2)	24.35	17.47	1.49	22.73	16.72	1.69	21.04	15.94	1.91	19.13	15.07	2.15	16.92	14.08	2.39	14.70	13.09	2.66
	67(19.4)	26.42	18.21	1.49	24.76	17.49	1.71	23.03	16.75	1.95	21.14	15.93	2.20	18.89	14.98	2.44	16.58	14.01	2.71
	72(22.2)	28.85	14.79	1.50	27.32	14.23	1.72	25.63	13.61	1.96	23.80	12.93	2.23	21.65	12.14	2.52	19.22	11.24	2.79
800/0.03	57(13.8)	24.12	24.12	1.50	22.76	22.76	1.71	21.34	21.34	1.94	19.80	19.80	2.18	17.99	17.99	2.43	16.19	16.19	2.72
	62(16.6)	24.50	23.07	1.50	22.90	22.19	1.71	21.38	21.38	1.94	19.84	19.84	2.18	18.02	18.02	2.44	16.22	16.22	2.72
	63*(17.2)	25.00	18.69	1.50	23.32	17.92	1.72	21.58	17.12	1.94	19.66	16.24	2.18	17.37	15.21	2.42	15.09	14.18	2.69
	67(19.4)	27.05	19.46	1.51	25.38	18.76	1.72	23.60	18.00	1.97	21.66	17.17	2.23	19.36	16.20	2.47	17.00	15.20	2.74
	72(22.2)	29.34	15.47	1.53	27.83	14.96	1.74	26.14	14.36	1.98	24.31	13.70	2.25	22.19	12.94	2.54	19.67	12.02	2.83
900/0.04	57(13.8)	25.11	25.11	1.52	23.69	23.69	1.74	22.22	22.22	1.97	20.65	20.65	2.22	18.78	18.78	2.47	16.90	16.90	2.76
	62(16.6)	25.16	25.16	1.52	23.73	23.73	1.74	22.26	22.26	1.97	20.68	20.68	2.22	18.81	18.81	2.47	16.93	16.93	2.76
	63*(17.2)	25.49	19.84	1.52	23.79	19.07	1.74	22.01	18.25	1.97	20.08	17.36	2.21	17.74	16.30	2.45	15.43	15.18	2.72
	67(19.4)	27.52	20.63	1.53	25.83	19.96	1.74	24.04	19.20	1.98	22.07	18.37	2.25	19.75	17.37	2.50	17.35	16.33	2.77
	72(22.2)	29.68	16.09	1.55	28.19	15.62	1.76	26.50	15.05	2.00	24.67	14.41	2.27	22.61	13.70	2.57	20.03	12.76	2.86

PAD430 COOLING EXTENDED PERFORMANCE TABLE

EVAPORATOR AIR		CONDENSER ENTERING AIR TEMPERATURES ° F (° C)																	
		75 (23.9)			85 (29.4)			95 (35)			105 (40.6)			115 (46.1)			125 (51.7)		
		CFM/BF	EWB ° F (° C)	Capacity MBtuh	Total Sys KW	Capacity MBtuh	Total Sys KW	Capacity MBtuh	Total Sys KW	Capacity MBtuh	Total Sys KW	Capacity MBtuh	Total Sys KW	Capacity MBtuh	Total Sys KW	Capacity MBtuh	Total Sys KW		
875/0.03	57(13.8)	26.99	26.99	1.86	26.03	26.03	2.08	24.84	24.84	2.31	23.28	23.28	2.55	21.63	21.63	2.82	19.83	19.83	3.11
	62(16.6)	27.80	26.01	1.87	26.54	25.26	2.08	25.04	24.35	2.31	23.33	23.33	2.55	21.67	21.67	2.82	19.87	19.87	3.11
	63*(17.2)	28.37	21.21	1.87	27.09	20.50	2.09	25.54	19.70	2.32	23.41	18.68	2.55	21.13	17.63	2.81	18.66	16.51	3.08
	67(19.4)	30.73	22.07	1.86	29.48	21.44	2.10	27.98	20.72	2.35	25.91	19.78	2.59	23.61	18.78	2.85	21.10	17.72	3.13
	72(22.2)	33.46	17.78	1.87	32.40	17.30	2.10	31.09	16.72	2.36	29.42	16.04	2.64	27.07	15.10	2.93	24.52	14.14	3.21
1000/0.04	57(13.8)	28.26	28.26	1.89	27.27	27.27	2.12	26.09	26.09	2.36	24.45	24.45	2.59	22.72	22.72	2.87	20.84	20.84	3.16
	62(16.6)	28.57	27.98	1.89	27.32	27.32	2.13	26.13	26.13	2.36	24.49	24.49	2.60	22.76	22.76	2.87	20.87	20.87	3.16
	63*(17.2)	29.05	22.65	1.89	27.73	21.95	2.13	26.16	21.15	2.36	23.97	20.11	2.59	21.65	19.03	2.85	19.13	17.84	3.12
	67(19.4)	31.37	23.54	1.89	30.12	22.95	2.12	28.60	22.25	2.38	26.53	21.33	2.63	24.15	20.29	2.89	21.60	19.20	3.18
	72(22.2)	33.95	18.56	1.90	32.92	18.14	2.14	31.61	17.60	2.39	30.05	16.99	2.68	27.65	16.09	2.98	25.04	15.12	3.26
1125/0.05	57(13.8)	29.32	29.32	1.92	28.31	28.31	2.15	27.10	27.10	2.41	25.45	25.45	2.64	23.65	23.65	2.91	21.70	21.70	3.21
	62(16.6)	29.36	29.36	1.92	28.35	28.35	2.15	27.14	27.14	2.41	25.49	25.49	2.64	23.68	23.68	2.92	21.73	21.73	3.21
	63*(17.2)	29.55	24.01	1.92	28.22	23.33	2.15	26.63	22.53	2.40	24.43	21.47	2.62	22.07	20.33	2.88	19.66	19.66	3.17
	67(19.4)	31.84	24.91	1.92	30.59	24.37	2.15	29.08	23.70	2.41	27.00	22.80	2.68	24.60	21.73	2.93	22.02	20.55	3.22
	72(22.2)	34.29	19.27	1.94	33.28	18.91	2.17	31.97	18.40	2.43	30.44	17.85	2.71	28.11	17.06	3.01	25.43	16.05	3.31

See Legend and Notes on following tables.

PAD436 COOLING EXTENDED PERFORMANCE TABLE

EVAPORATOR AIR		CONDENSER ENTERING AIR TEMPERATURES °F (°C)																	
		75 (23.9)			85 (29.4)			95 (35)			105 (40.6)			115 (46.1)			125 (51.7)		
		Capacity MBtuh	Total Sys KW	Total Sys KW	Capacity MBtuh	Total Sys KW	Total Sys KW	Capacity MBtuh	Total Sys KW	Total Sys KW	Capacity MBtuh	Total Sys KW	Total Sys KW	Capacity MBtuh	Total Sys KW	Total Sys KW	Capacity MBtuh	Total Sys KW	Total Sys KW
CFM/BF	EWB °F (°C)	Total	Sens	Total	Sens	Total	Sens	Total	Sens	Total	Sens	Total	Sens	Total	Sens	Total	Sens	Total	Sens
		1050/0.04	57(13.8)	32.04	32.04	2.19	31.05	31.05	2.46	29.67	29.67	2.74	27.89	27.89	3.04	25.97	25.97	3.38	23.86
62(16.6)	32.91		27.48	2.20	31.59	27.24	2.46	29.83	29.66	2.74	27.93	27.93	3.04	26.01	26.01	3.38	23.90	23.90	3.76
63*(17.2)	33.62		22.38	2.21	32.24	22.10	2.47	30.40	21.63	2.75	27.88	20.90	3.04	25.18	20.09	3.37	22.23	19.16	3.72
67(19.4)	36.45		23.33	2.21	35.13	23.14	2.49	33.48	22.83	2.80	30.96	22.18	3.09	28.22	21.45	3.42	25.24	20.62	3.78
72(22.2)	39.67		18.74	2.22	38.63	18.63	2.50	37.24	18.38	2.81	35.25	17.95	3.16	32.48	17.21	3.51	29.45	16.41	3.88
57(13.8)	33.50		33.50	2.25	32.48	32.48	2.53	31.16	31.16	2.81	29.25	29.25	3.11	27.24	27.24	3.46	25.04	25.04	3.83
1200/0.05	62(16.6)	33.79	29.49	2.25	32.53	32.53	2.53	31.22	31.22	2.82	29.30	29.30	3.11	27.28	27.28	3.46	25.08	25.08	3.84
	63*(17.2)	34.36	23.89	2.25	32.96	23.65	2.53	31.14	23.23	2.81	28.52	22.48	3.10	25.75	21.66	3.43	22.79	20.63	3.79
	67(19.4)	37.19	24.89	2.25	35.85	24.76	2.54	34.20	24.50	2.85	31.64	23.89	3.16	28.84	23.16	3.49	25.80	22.30	3.85
	72(22.2)	40.13	19.52	2.27	39.14	19.50	2.55	37.77	19.31	2.86	35.97	19.03	3.21	33.15	18.34	3.58	30.03	17.54	3.95
	57(13.8)	34.72	34.72	2.30	33.67	33.67	2.58	32.38	32.38	2.89	30.42	30.42	3.18	28.32	28.32	3.53	26.03	26.03	3.91
	62(16.6)	34.77	34.77	2.30	33.72	33.72	2.58	32.42	32.42	2.89	30.47	30.47	3.19	28.36	28.36	3.53	26.07	26.07	3.91
1350/0.06	63*(17.2)	34.95	25.34	2.30	33.50	25.12	2.58	31.73	24.75	2.88	29.03	23.98	3.16	26.24	23.10	3.49	23.49	23.49	3.85
	67(19.4)	37.71	26.36	2.30	36.39	26.30	2.58	34.73	26.08	2.90	32.19	25.52	3.22	29.33	24.77	3.55	26.31	23.80	3.92
	72(22.2)	40.41	20.21	2.32	39.47	20.28	2.60	38.09	20.14	2.91	36.46	20.02	3.26	33.65	19.42	3.64	30.47	18.63	4.02

PAD442 COOLING EXTENDED PERFORMANCE TABLE

EVAPORATOR AIR		CONDENSER ENTERING AIR TEMPERATURES °F (°C)																	
		75 (23.9)			85 (29.4)			95 (35)			105 (40.6)			115 (46.1)			125 (51.7)		
		Capacity MBtuh	Total Sys KW	Total Sys KW	Capacity MBtuh	Total Sys KW	Total Sys KW	Capacity MBtuh	Total Sys KW	Total Sys KW	Capacity MBtuh	Total Sys KW	Total Sys KW	Capacity MBtuh	Total Sys KW	Total Sys KW	Capacity MBtuh	Total Sys KW	Total Sys KW
CFM/BF	EWB °F (°C)	Total	Sens	Total	Sens	Total	Sens	Total	Sens	Total	Sens	Total	Sens	Total	Sens	Total	Sens	Total	Sens
		1225/0.03	57(13.8)	39.61	39.61	2.72	37.75	37.75	3.11	35.18	35.18	3.47	32.60	32.60	3.87	29.87	29.87	4.29	27.01
62(16.6)	41.07		38.45	2.67	38.75	36.39	3.09	35.55	33.89	3.46	32.66	32.66	3.87	29.92	29.92	4.29	27.06	27.06	4.72
63*(17.2)	41.95		31.44	2.64	39.60	29.62	3.07	36.33	27.46	3.45	32.90	25.32	3.87	29.27	23.19	4.30	25.42	21.06	4.73
67(19.4)	45.37		32.67	2.53	43.06	30.92	2.96	39.97	28.94	3.40	36.45	26.82	3.83	32.72	24.71	4.27	28.81	22.62	4.72
72(22.2)	49.27		26.39	2.42	46.93	24.87	2.85	44.47	23.37	3.31	41.33	21.77	3.74	37.56	19.92	4.23	33.52	18.06	4.71
57(13.8)	41.50		41.50	2.69	39.58	39.58	3.11	36.97	36.97	3.49	34.25	34.25	3.90	31.39	31.39	4.32	28.40	28.40	4.76
1400/0.04	62(16.6)	42.21	41.36	2.67	39.89	39.13	3.10	37.03	37.03	3.49	34.31	34.31	3.89	31.45	31.45	4.32	28.45	28.45	4.76
	63*(17.2)	42.97	33.53	2.65	40.58	31.68	3.08	37.25	29.48	3.49	33.72	27.26	3.90	29.98	25.02	4.34	26.10	22.75	4.77
	67(19.4)	46.35	34.80	2.54	43.98	33.00	2.97	41.00	31.10	3.42	37.31	28.90	3.87	33.50	26.70	4.31	29.50	24.50	4.76
	72(22.2)	50.00	27.51	2.44	47.63	26.00	2.87	45.07	24.46	3.33	42.19	23.04	3.76	38.40	21.21	4.25	34.25	19.32	4.76
	57(13.8)	49.07	43.07	2.68	41.12	41.12	3.10	38.51	38.51	3.52	35.67	35.67	3.92	32.70	32.70	4.36	29.59	29.59	4.80
	62(16.6)	43.17	43.17	2.68	41.17	41.17	3.10	38.57	38.57	3.52	35.73	35.73	3.92	32.75	32.75	4.36	29.63	29.63	4.80
1575/0.05	63*(17.2)	43.75	35.51	2.67	41.32	33.62	3.10	37.99	31.40	3.52	34.37	29.08	3.94	30.58	26.74	4.37	26.77	26.77	4.81
	67(19.4)	47.03	36.77	2.56	44.64	34.95	2.99	41.77	33.12	3.44	38.00	30.88	3.90	34.12	28.58	4.35	30.10	26.23	4.80
	72(22.2)	50.51	28.53	2.47	48.10	27.01	2.90	45.48	25.44	3.37	42.80	24.21	3.79	39.02	22.42	4.27	34.83	20.52	4.79

PAD448 COOLING EXTENDED PERFORMANCE TABLE

EVAPORATOR AIR		CONDENSER ENTERING AIR TEMPERATURES ° F (° C)																	
		75 (23.9)			85 (29.4)			95 (35)			105 (40.6)			115 (46.1)			125 (51.7)		
		CFM/BF	EWB ° F (° C)	Capacity MBtuh		Total Sys KW	Capacity MBtuh		Total Sys KW	Capacity MBtuh		Total Sys KW	Capacity MBtuh		Total Sys KW	Capacity MBtuh		Total Sys KW	
Total	Sens			Total	Sens		Total	Sens		Total	Sens		Total	Sens					
1400/0.04	57(13.8)	45.84	43.32	43.32	3.39	40.27	36.93	3.79	36.93	36.93	4.23	33.57	33.57	4.70	30.16	30.16	5.21		
	62(16.6)	47.63	44.58	40.08	3.40	40.96	36.99	3.80	36.99	36.99	4.23	33.63	33.63	4.70	30.21	30.21	5.21		
	63*(17.2)	48.63	34.72	32.68	3.41	41.85	37.52	3.82	37.52	28.03	4.23	33.20	25.66	4.69	28.77	23.31	5.18		
	67(19.4)	52.66	36.12	34.10	3.41	46.02	32.06	3.86	41.50	29.66	4.31	37.03	27.31	4.77	32.47	24.99	5.27		
	72(22.2)	57.51	29.34	27.62	3.41	50.75	25.85	3.86	46.93	24.09	4.35	42.34	22.07	4.88	37.63	20.03	5.42		
1600/0.05	57(13.8)	47.96	45.32	45.32	3.47	42.32	38.76	3.89	38.76	38.76	4.32	35.24	35.24	4.80	31.66	31.66	5.31		
	62(16.6)	48.90	45.80	43.03	3.47	42.41	38.82	3.89	38.82	38.82	4.32	35.30	35.30	4.80	31.72	31.72	5.32		
	63*(17.2)	49.79	37.01	34.90	3.47	42.93	32.66	3.90	38.42	30.10	4.31	33.97	27.62	4.77	29.47	25.14	5.26		
	67(19.4)	53.81	38.48	36.40	3.46	47.00	34.30	3.92	42.43	31.88	4.39	37.88	29.44	4.86	33.20	27.00	5.35		
	72(22.2)	58.37	30.60	28.87	3.47	51.47	27.05	3.93	47.81	25.40	4.41	43.22	23.43	4.94	38.39	21.38	5.50		
1800/0.06	57(13.8)	49.74	47.00	47.00	3.53	44.06	44.06	3.98	40.29	40.29	4.41	36.64	36.64	4.89	32.92	32.92	5.41		
	62(16.6)	50.02	49.61	47.06	3.53	44.13	44.13	3.98	40.35	40.35	4.41	36.69	36.69	4.89	32.97	32.97	5.41		
	63*(17.2)	50.68	39.21	37.03	3.53	43.79	34.77	3.98	39.13	32.09	4.38	34.61	29.48	4.84	30.08	26.75	5.33		
	67(19.4)	54.66	40.72	38.58	3.52	47.75	36.43	3.97	43.18	34.03	4.47	38.53	31.47	4.93	33.83	28.88	5.44		
	72(22.2)	58.98	31.74	30.01	3.53	51.97	28.16	3.99	48.35	26.51	4.48	43.87	24.71	4.99	38.98	22.66	5.56		

PAD460 COOLING EXTENDED PERFORMANCE TABLE

EVAPORATOR AIR		CONDENSER ENTERING AIR TEMPERATURES ° F (° C)																	
		75 (23.9)			85 (29.4)			95 (35)			105 (40.6)			115 (46.1)			125 (51.7)		
		CFM/BF	EWB ° F (° C)	Capacity MBtuh		Total Sys KW	Capacity MBtuh		Total Sys KW	Capacity MBtuh		Total Sys KW	Capacity MBtuh		Total Sys KW	Capacity MBtuh		Total Sys KW	
Total	Sens			Total	Sens		Total	Sens		Total	Sens		Total	Sens					
1750/0.19	57(13.8)	57.97	55.02	55.02	4.21	51.93	48.68	4.68	48.68	48.68	5.21	45.23	45.23	5.81	41.56	41.56	6.49		
	62(16.6)	59.45	53.94	51.73	4.22	52.32	49.43	4.68	48.74	48.74	5.21	45.29	45.29	5.81	41.61	41.61	6.49		
	63*(17.2)	60.48	43.88	41.90	4.23	53.09	39.89	4.69	49.17	37.85	5.21	45.08	35.75	5.80	40.81	33.61	6.47		
	67(19.4)	65.05	45.58	43.55	4.29	57.00	41.50	4.75	52.75	39.41	5.27	48.31	37.28	5.86	43.70	35.10	6.52		
	72(22.2)	71.36	36.96	35.08	4.38	62.43	33.17	4.83	57.72	31.22	5.35	52.82	29.25	5.94	47.74	27.24	6.59		
2000/0.23	57(13.8)	60.36	60.36	57.19	4.32	53.88	53.88	4.79	50.41	50.41	5.31	46.72	46.72	5.91	42.83	42.83	6.59		
	62(16.6)	60.82	57.92	57.29	4.32	53.96	53.96	4.79	50.47	50.47	5.32	46.78	46.78	5.92	42.88	42.88	6.59		
	63*(17.2)	61.65	46.80	44.73	4.33	53.93	42.64	4.78	49.88	40.51	5.30	45.65	38.32	5.89	41.27	36.06	6.56		
	67(19.4)	66.24	48.72	46.60	4.39	57.86	44.46	4.85	53.47	42.28	5.36	48.88	40.05	5.95	44.14	37.77	6.61		
	72(22.2)	72.62	38.94	36.99	4.47	63.32	35.02	4.93	58.45	33.03	5.45	53.38	30.99	6.03	48.15	28.93	6.68		
2250/0.27	57(13.8)	62.35	62.35	58.99	4.43	55.49	55.49	4.89	51.82	51.82	5.42	47.93	47.93	6.02	43.84	43.84	6.69		
	62(16.6)	62.44	62.44	59.07	4.43	55.56	55.56	4.89	51.88	51.88	5.42	47.99	47.99	6.02	43.88	43.88	6.69		
	63*(17.2)	62.51	49.60	47.45	4.42	54.57	45.27	4.87	50.40	43.04	5.39	46.08	40.74	5.98	41.62	38.30	6.65		
	67(19.4)	67.13	51.74	49.53	4.48	58.50	47.31	4.94	53.98	45.03	5.46	49.29	42.69	6.04	44.47	40.24	6.70		
	72(22.2)	73.55	40.84	38.84	4.57	63.97	36.82	5.02	58.95	34.76	5.54	53.76	32.68	6.12	48.40	30.58	6.77		

* At 75°F (24°C) entering dry bulb—Tennessee Valley Authority (TVA) rating conditions; all others at 80°F (27°C)

dry bulb

LEGEND:

BF— Bypass Factor

Edb— Entering Dry-Bulb

Ewb— Entering Wet-Bulb

kw — Total Unit Power Input

SHC— Sensible Heat Capacity (1000 Btuh)

TC — Total Capacity (1000 Btuh) (net)

rh—Relative Humidity

COOLING NOTES:

1. Ratings are net; they account for the effects of the evaporator-fan motor power and heat.
2. Direct interpolation is permissible. Do not extrapolate.
3. The following formulas may be used:
 - $\dot{q}_{Ldb} = \dot{q}_{Edb} - \frac{\text{Sensible Capacity (Btuh)}}{1.10 \text{ x cfm}}$
 - $\dot{q}_{Lwb} = \dot{q}_{Ewb} - \frac{\text{Total Capacity (Btuh)}}{4.5 \text{ x cfm}}$
4. \dot{q}_{Lwb} = Wet bulb temperature corresponding to enthalpy of air leaving evaporator coil (h_{Lwb})
 Where: h_{Ewb} = Enthalpy of air entering evaporator coil
 The SHC is based on 80 °F Edb temperature of air entering evaporator coil
5. Below 80 °F Edb, subtract (corr factor x cfm) from SHC.
 Above 80 °F Edb, add (corr factor x cfm) to SHC. Correction Factor = 1.10 x (1 + BF) x (Edb + 80).
 Integrated capacity is maximum (instantaneous) capacity less the effect of frost on the outdoor coil and the heat required to defrost it.

PAD4	ELECTRICAL CHARACTERISTICS	UNIT WT.		UNIT HEIGHT IN/MM		CENTER OF GRAVITY IN/MM	
		LB	KG	"A"	"Y"	"X"	"Z"
24	200/230	288	130.5	38-15/16 [1014.4]	20-1/2 [520.7]	15-3/4 [400.1]	16-5/8 [422.3]
30	200/230	300	136.0	38-15/16 [1014.4]	20-1/2 [520.7]	15-3/4 [400.1]	16-5/8 [422.3]
36	200/230	358	162.3	45-15/16 [1166.8]	20-1/2 [520.7]	15-3/4 [400.1]	17-3/8 [441.3]

PAD4	CORNER WEIGHT LB/KG			REQUIRED CLEARANCES TO COMBUSTIBLE IN/ML		
	"1"	"2"	"4"	TOP OF UNIT	SIDE OF UNIT	BOTTOM OF UNIT
24	57.6 [26.1]	46.0 [20.9]	69.1 [31.4]	15-1/8 [391.3]	15-1/8 [391.3]	15-1/8 [391.3]
30	60.0 [27.2]	48.0 [21.8]	71.9 [32.7]	15-1/8 [391.3]	15-1/8 [391.3]	15-1/8 [391.3]
36	71.6 [32.5]	57.2 [26.0]	85.9 [38.9]	15-1/8 [391.3]	15-1/8 [391.3]	15-1/8 [391.3]

REQUIRED CLEARANCES TO COMBUSTIBLE IN/ML

TOP OF UNIT.....15-1/8 [391.3]
 SIDE OF UNIT.....15-1/8 [391.3]
 BOTTOM OF UNIT.....15-1/8 [391.3]
 ELECTRICAL PANEL.....36 [914.4]

REQ. REQUIRED CLEARANCES

BETWEEN UNITS, POWER ENTRY SIDE.....42 [1066.8]
 UNIT AND UNGROUND SURFACES, POWER ENTRY SIDE.....36 [914.0]
 UNIT AND BLOCK OR CONCRETE WALLS AND OTHER UNGROUND SURFACES, POWER ENTRY SIDE.....42 [1066.8]

REQUIRED CLEARANCE FOR OPERATION AND SERVICING

FURF. COIL ACCESS SIDE.....42 [1066.8]
 POWER ENTRY SIDE.....48 [1219.2]
 (EXCEPT FOR NEC REQUIREMENTS)
 UNIT TOP.....48 [1219.2]
 SIDE OPPOSITE DUCTS.....36 [914.0]
 DUCT PANEL.....12 [304.8]

*MINIMUM DISTANCES: IF UNIT IS PLACED LESS THAN 12 [304.8] FROM WALL SYSTEM, THEN SYSTEM PERFORMANCE MAY BE COMPROMISED.

DIMENSIONS IN () ARE IN MILLIMETERS

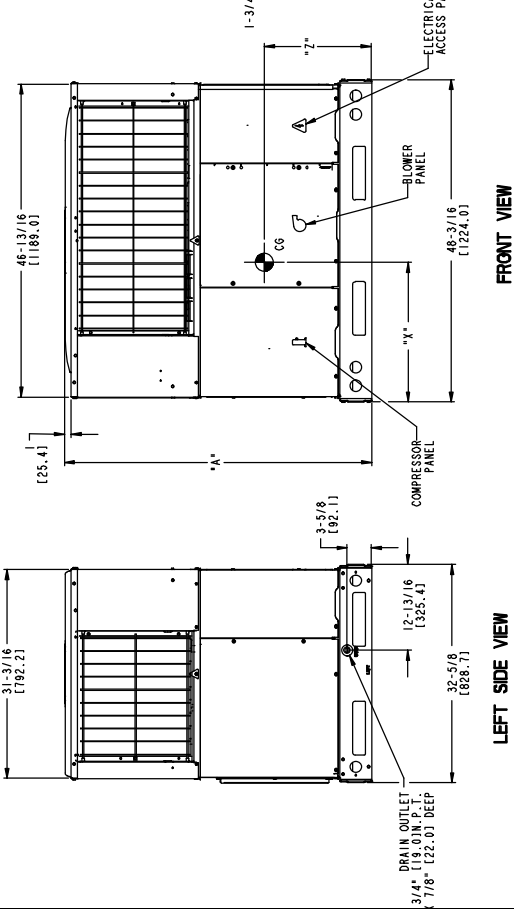
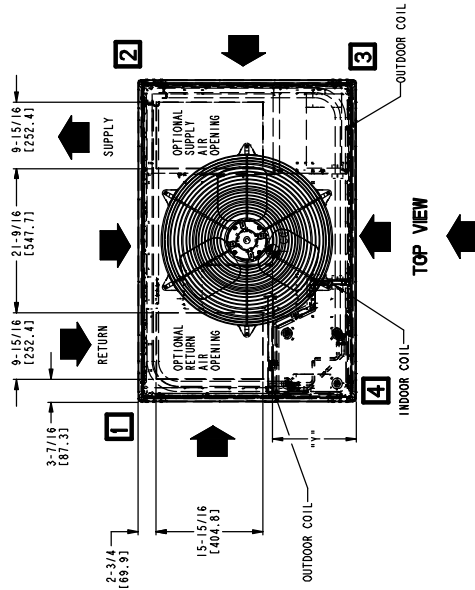

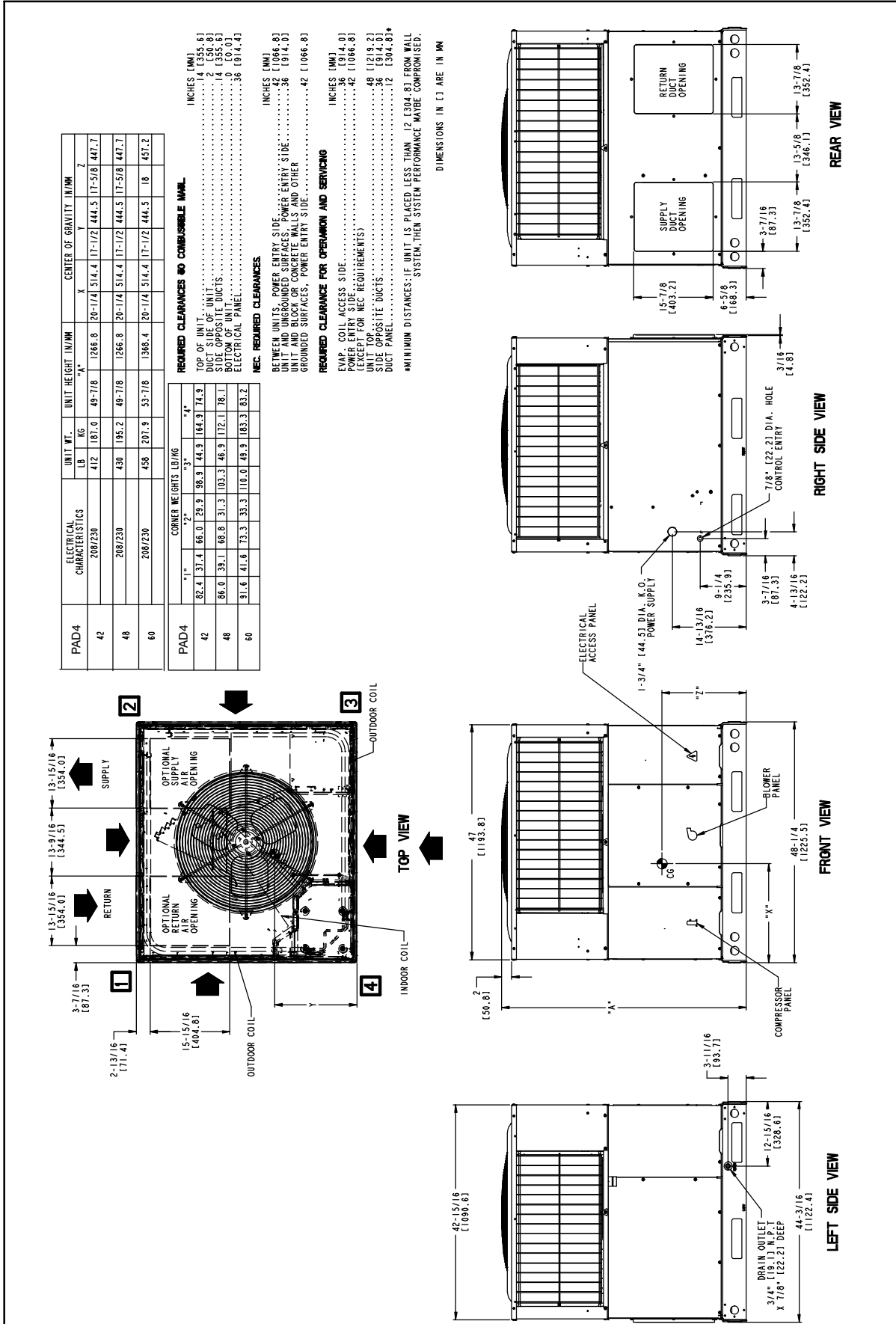

CONNECTION WIRING DIAGRAM

DANGER: ELECTRICAL SHOCK HAZARD DISCONNECT POWER BEFORE SERVICING

SCHEMATIC
230-1-60

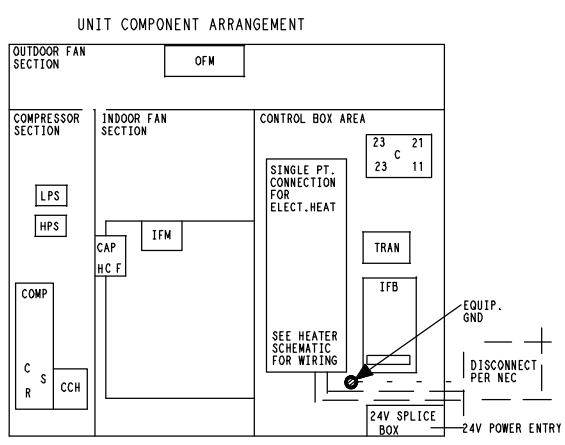
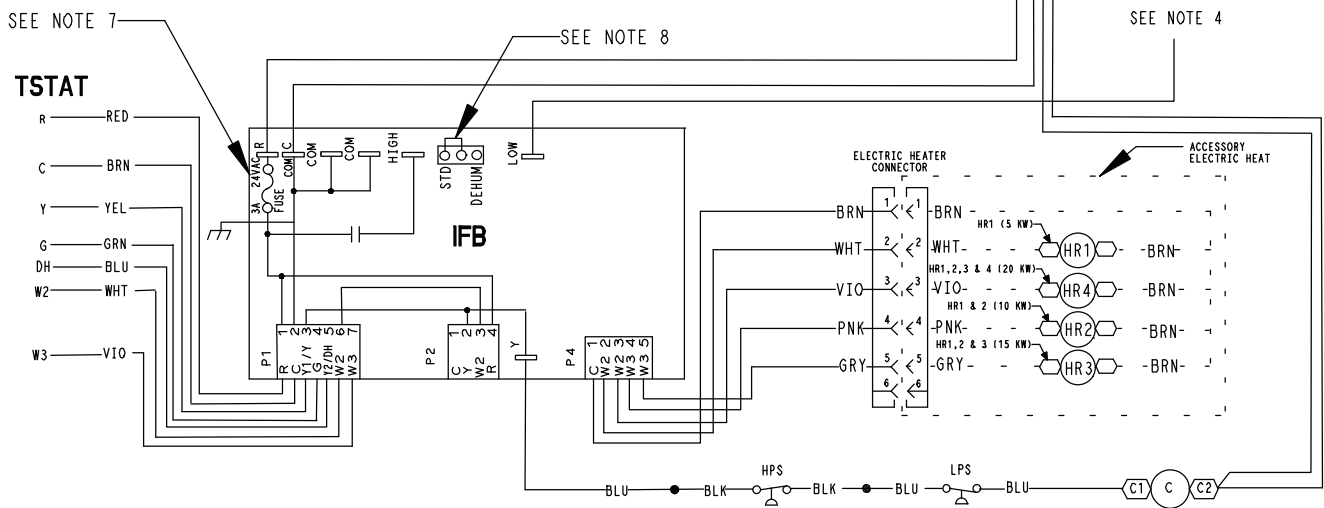
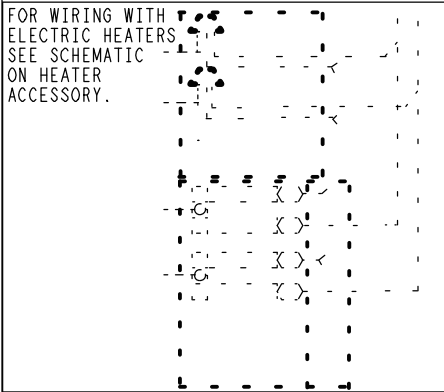
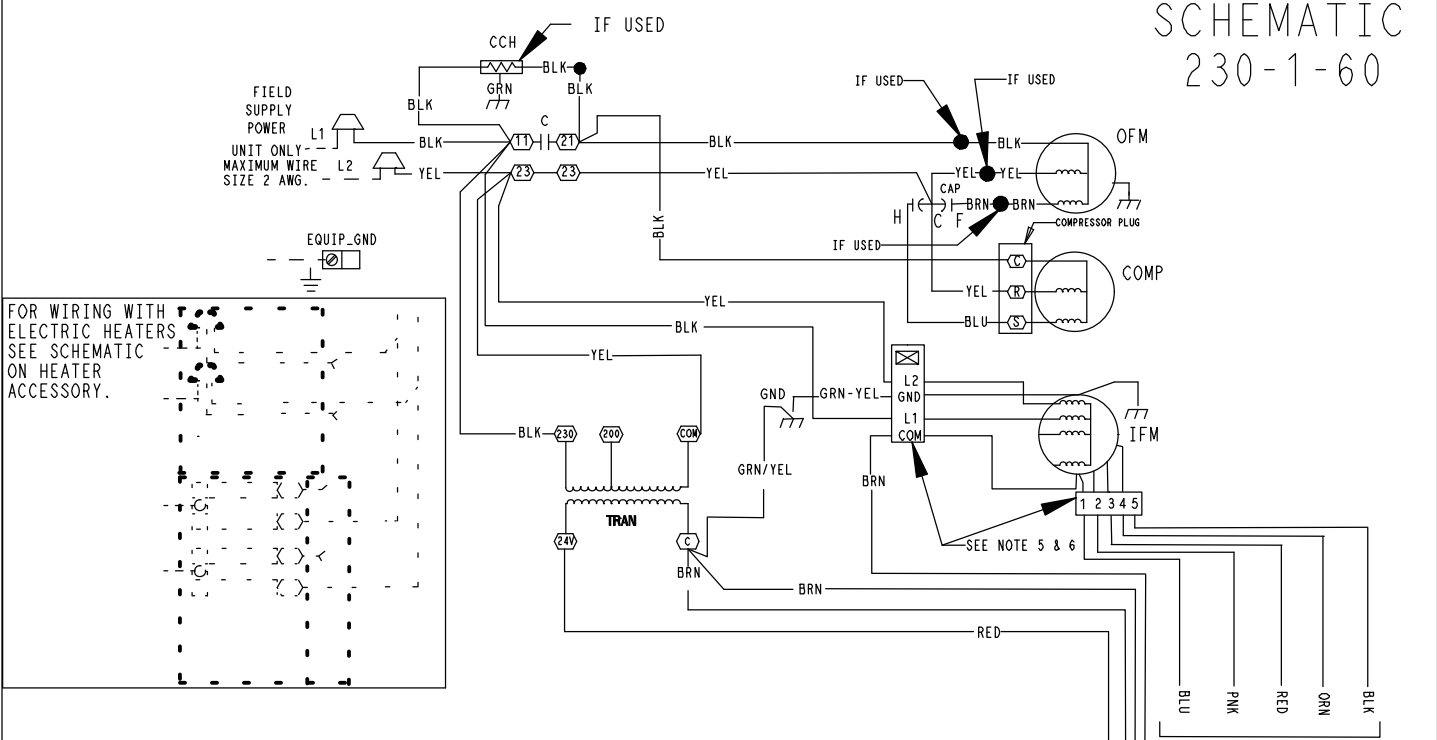

LEGEND

△	FIELD SPLICE	C	CONTACTOR
○	TERMINAL (MARKED) ENERGIZED	CAP	CAPACITOR
○	TERMINAL (UNMARKED)	CCH	CRANK CASE HEATER
●	SPLICE (IF USED)	COMP	COMPRESSOR MOTOR
○	SPLICE (MARKED)	DEHUM	DEHUMIDIFICATION MODE
—	FACTORY WIRING	GND	GROUND
- - -	FIELD CONTROL WIRING	HPS	HIGH PRESSURE SWITCH
- - -	FIELD POWER WIRING	HR	HEATER RELAY
- - -	ACCESSORY OR OPTIONAL WIRING	IFB	INTERFACE FAN BOARD
—	TO INDICATE COMMON POTENTIAL ONLY: NOT TO REPRESENT WIRING	IFM	INDOOR FAN MOTOR
		LPS	LOW PRESSURE SWITCH
		OFM	OUTDOOR FAN MOTOR
		STD	STANDARD
		TRAN	TRANSFORMER

- NOTES:**
- IF ANY OF THE ORIGINAL WIRES FURNISHED ARE REPLACED, IT MUST BE REPLACED WITH TYPE 90 DEGREE C WIRE OR IT'S EQUIVALENT.
 - USE 75 DEGREE COPPER CONDUCTORS FOR FIELD INSTALLATION.
 - REFER TO INSTALLATION INSTRUCTIONS FOR CORRECT SPEED SELECTION OF IFM.
 - RELOCATION OF SPEED TAPS MAY BE REQUIRED WHEN USING FIELD INSTALLED ELECTRIC HEATERS, CONSULT INSTALLATION INSTRUCTIONS TO DETERMINE CORRECT SPEED TAP SETTING.
 - DO NOT DISCONNECT PLUS UNDER LOAD.
 - THIS FUSE IS MANUFACTURED BY LITTELFUSE, P/N 257003.
 - UNIT FACTORY-SHIPED IN STD MODE.

LADDER WIRING DIAGRAM

DANGER: ELECTRICAL SHOCK HAZARD DISCONNECT POWER BEFORE SERVICING

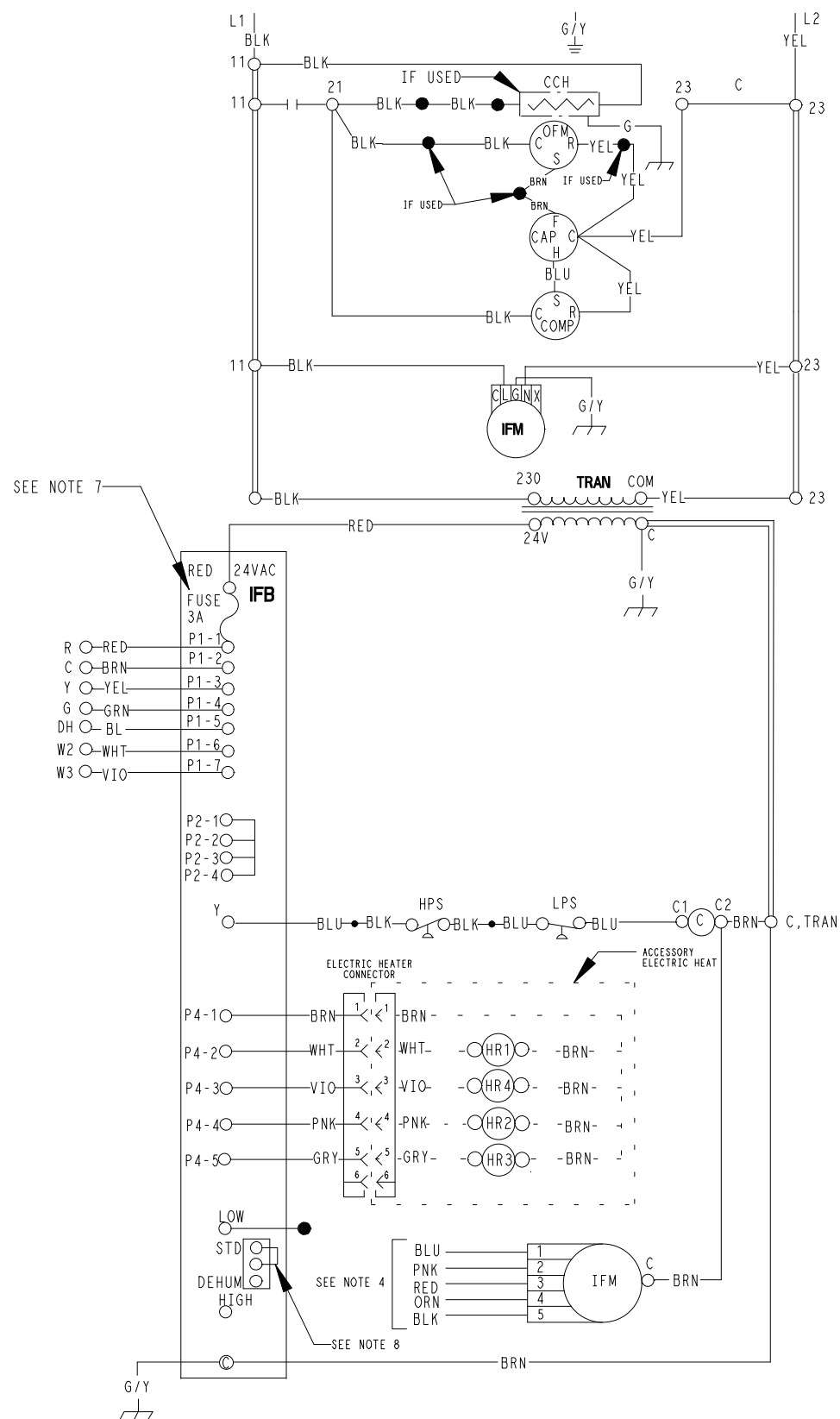

50VL500269

E

CONTROLS

Operating sequence

Cooling — When the system thermostat calls for cooling, 24 V is supplied to the “Y” and “G” terminals of the thermostat. This completes the circuit to the contactor coil (C) and indoor (evaporator) fan relay (IFR). The normally open contacts of energized C close and complete the circuit through compressor motor (COMP) to outdoor (condenser) fan motor (OFM). Both motors start instantly. The set of normally open contacts of energized IFR close and complete the circuit through IFM. The IFM starts instantly.

On the loss of the thermostat call for cooling, 24 V is removed from both the “Y” and “G” terminals (provided the fan switch is in the “AUTO” position) de-energizing the compressor contactor and opening the contacts supplying power to compressor/OFM. After a 90-second delay, the IFM shuts off. If the thermostat fan selector switch is in the “ON” position, the IFM will run continuously. For the 460 V units there is a step down auto-transformer supplying 230 V to the Indoor Fan Motor.

NOTE: On units with anti-cycle timer: Once the compressor has started and then stopped, it cannot be restarted again until 5 minutes have elapsed.

Heating — If accessory electric heaters are installed, on a call for heat, circuit R-W is made through the thermostat contacts. Circuit R-G is made which energizes the IFR. If the heaters are staged, then the thermostat closes a second set of contacts (W2) when second stage is required. When thermostat is satisfied, contacts open, de-energizing the heater relay and the IFR.

ACCESSORIES

ROOF CURBS

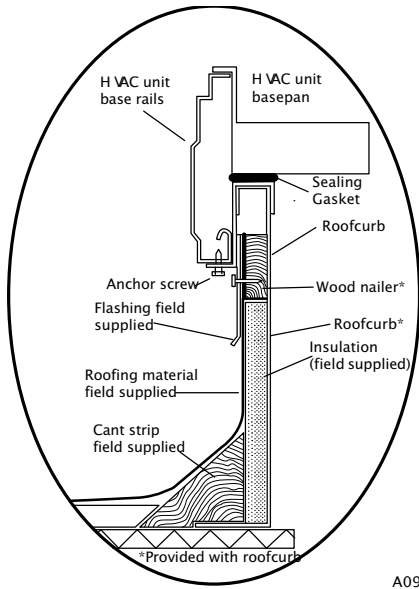

A09090

ROOF CURB DETAIL

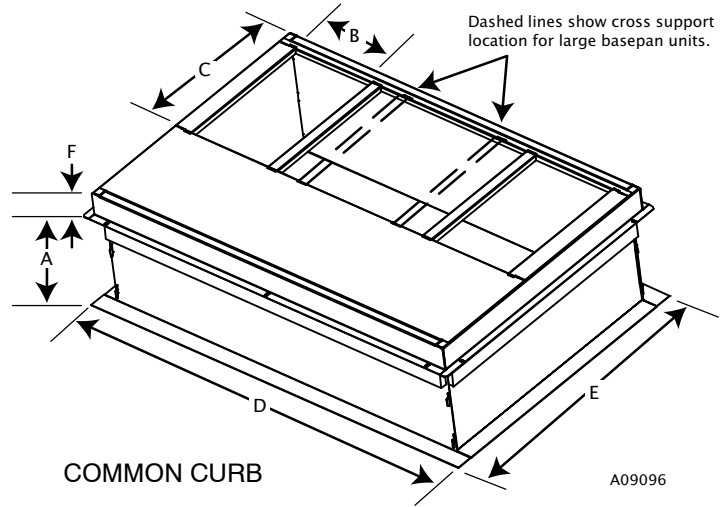

COMMON CURB

A09096

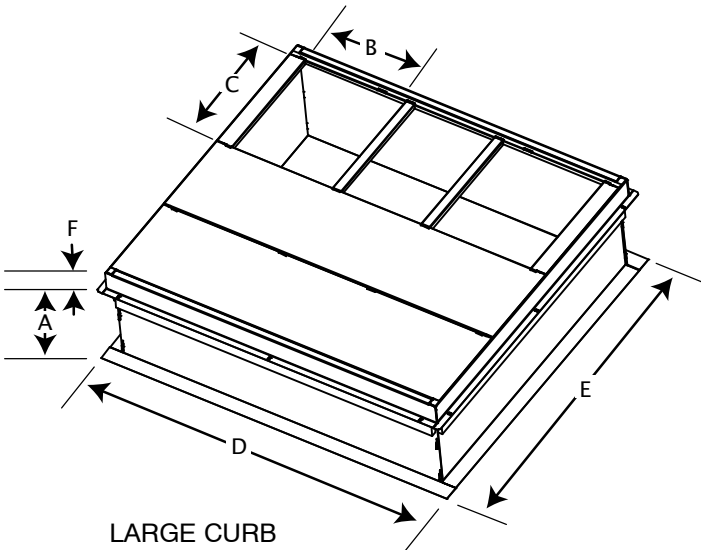

LARGE CURB

A09095

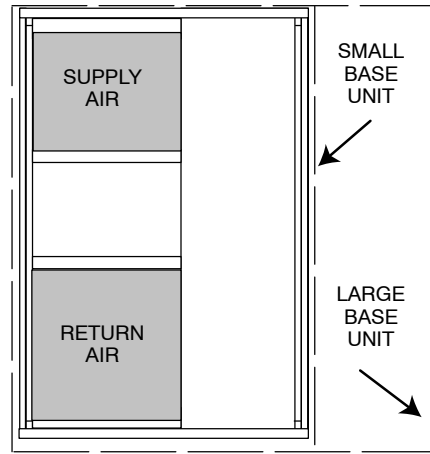

UNIT PLACEMENT ON COMMON CURB

A09094

SMALL OR LARGE BASE UNIT

UNIT SIZE	CATALOG NUMBER	A IN. (mm)	B (small base) IN. (mm)*	B (large base) IN. (mm)*	C IN. (mm)	D IN. (mm)	E IN. (mm)	F IN. (mm)
Small or Large	CPRFCURB010A00	11 (279)	10 (254)	14 (356)	16 (406)	47.8 (1214)	32.4 (822)	2.7 (69)
	CPRFCURB011A00	14 (356)						
Large	CPRFCURB012A00	11 (279)	14 (356)	14 (356)	16 (406)	47.8 (1214)	43.9 (1116)	2.7 (69)
	CPRFCURB013A00	14 (356)						

* Part Numbers CPRFCURB010A00 and CPRFCURB011A00 can be used on both small and large basepan units. The cross supports must be located based on whether the unit is a small basepan or a large basepan.

NOTES:

1. Roof curb must be set up for unit being installed.
2. Seal strip must be applied, as required, to unit being installed.
3. Roof curb is made of 16-gauge steel.
4. Attach ductwork to curb (flanges of duct rest on curb).
5. Insulated panels: 1-in. (25.4 mm) thick fiberglass 1 lb. density.

PAD4 ACCESSORIES (Continued)

Accessory Model Number	Description	Use With
CURBS		
CPRFCURB010A00	Roof Curb, 11" High	24 – 60
CPRFCURB011A00	Roof Curb, 14" High	24 – 60
CPRFCURB012A00	Roof Curb, 11" High	42 – 60
CPRFCURB013A00	Roof Curb, 14" High	42 – 60
Note: CPRFCURB010A00 AND CPRFCURB011A00 can be used with 42–60 size units with some overhang.		
ADAPTER CURBS*		
CPADCURB001A00	Adapter curb for use with NPRFCURB006A00 & NPRFCURB007A00	24 – 36
CPADCURB002A00	Adapter curb for use with NPRFCURB008A00 & NPRFCURB009A00	42 – 60
* Can also be used when replacing other manufacturer's older generation units that contain a composite base without a metal base rail.		
CONCENTRIC ADAPTERS – (Use with curb only)		
NPCONADP001A00	For 18" round duct (use with curbs CPRFCURB010A00, CPRFCURB011A00)	Small Curb
NPCONADP002A00	For 18" round duct (use with curbs CPRFCURB012A00, CPRFCURB013A00)	Large Curb
CONCENTRIC DIFFUSERS – (Ceiling or under roof)		
AXB020CSA*	Step Down Diffuser – Fits 2' x 4' Ceiling Grid (16" round collars for flex conn.)	24 – 42
AXB020CFA*	Flush Mount Diffuser – Fits 2' x 4' Ceiling Grid (16" round collars for flex conn.)	24 – 42
AXB030CSA	Step Down Diffuser – Fits 2' x 4' Ceiling Grid (18" round collars for flex conn.)	24 – 60
AXB030CFA	Flush Mount Diffuser – Fits 2' x 4' Ceiling Grid (18" round collars for flex conn.)	24 – 60
* A field supplied 18" to 16" round reducer required when used with NP concentric adaptor		
ECONOMIZERS		
CPECOMZR007A00	Dedicated Vertical Economizer – Internal with solid state controller, gear driven, fully modulating damper, spring return actuator, up to 50% barometric relief, supply and dry bulb outdoor air sensors. Includes filter rack with 1" filters*.	24 – 36
CPECOMZR008A00		42, 48
CPECOMZR009A00		60
CPECOMZR010A00	Dedicated Horizontal Economizer – Internal with solid state controller, fully modulating damper, spring return actuator, supply and dry bulb outdoor air sensor, and low ambient compressor lockout switch included. Includes filter rack with 1–inch filters*.	24 – 36
CPECOMZR011A00		42, 48
CPECOMZR012A00		60
AXB078ENT	Outdoor Enthalpy Control	ALL
* Outdoor enthalpy available as field installed accessory; Filter rack and 1" filter, same as CPFILTRK kit		
DAMPERS		
CPMANDPR007A00	Manual Outside Air Damper – (Includes filter rack and 1" filter, same as CPFILTRK kit)	24 – 36
CPMANDPR008A00		42, 48
CPMANDPR009A00		60
INTERNAL FILTER RACKS		
CPFILTRK007A00	Internal Filter Rack (includes 1–inch filters)	24 – 36
CPFILTRK008A00		42, 48
CPFILTRK009A00		60
LOW AMBIENT, ANTI-CYCLE TIMER, COMPRESSOR START ASSIST		
CPLOWAMB001A00 (AXB035LAA)	Low Ambient Control – enables cooling system to operate down to 0 Deg. F by cycling condenser fan on and off.	ALL
NRTIMEGD001A00	Five Minute Compressor Delay	ALL
CPHSTART002A00	PTC Compressor Start Assist Kit	ALL
CRANKCASE HEATER – BELLY BAND TYPE		
NPCRKHTR008A00	240V Crankcase Heater	24 – 36
NPCRKHTR004A00	240V Crankcase Heater	42 – 60
HAIL GUARDS / COIL PROTECTION (Factory installed on PAD**000KTP models)		
NAPA00501GR	3/8" spacing dense wire grilles	24
NAPA00701GR	3/8" spacing dense wire grilles	30
NAPA00901GR	3/8" spacing dense wire grilles	36
NAPA00601GR	3/8" spacing dense wire grilles	42
NAPA01001GR	3/8" spacing dense wire grilles	48
NAPA01201GR	3/8" spacing dense wire grilles	60
DUCT TRANSITIONS		
NPDUCFLG002A00	Square to Round (1 set of 2, use with horizontal duct flanges only)	24–48

PAD4 ACCESSORIES (Continued)

ELECTRIC HEATERS					
Voltage / Nominal Capacity kW / Fuses					
PART NO.	NOMINAL CAPACITY (kW)	FUSED	# FUSES	STAGES	USED WITH
EHNA05K0N	3.8 / 5.0	NO	0	1	ALL
EHNA05K4F	3.8 / 5.0	YES	4	1	ALL
EHNA07K0N	5.4 / 7.2	NO	0	2	ALL
EHNA07K4F	5.4 / 7.2	YES	4	2	ALL
EHNA10K0N	7.5 / 10.0	NO	0	2	24 - 42
EHNA10K4F	7.5 / 10.0	YES	4	2	ALL
EHNA15K4F	11.3 / 15.0	YES	4	2	30 - 42
EHNA15K6F	11.3 / 15.0	YES	6	2	30 - 60
EHNA20K4F	15.0 / 20.0	YES	4	2	42
EHNA20K6F	15.0 / 20.0	YES	6	2	42 - 60
DUAL POINT WIRING KIT					
CPDUALPT001A00	Dual Point Wiring kit, 5-20kW Heaters				ALL