

DIRECT EXPANSION COMMERCIAL PACKAGED AIR HANDLING UNITS, 6 – 25 TONS BUILT TO LAST, EASY TO INSTALL AND SERVICE

- Multi-position design for horizontal or vertical installation without modification.
- Two sloped condensate pans on each unit for horizontal or vertical applications.
- Standard sloped drain pans and cleanable insulation treated with Environmental Protection Agency (EPA) registered antimicrobial agent improves indoor air quality.
- High-static design meets a wider range of applications than competitive packaged air handler lines
- Ultra low leak economizer accessory provides ventilation air and “free” cooling with built in Fault Detection and Diagnostic (FDD) capabilities
- Single refrigerant circuit on 072 and 091 sizes. Dual refrigerant circuit on 120–300 sizes. Dual circuit can be field modified for use on single circuit condensers.
- Cooling coils with mechanically bonded fins provide peak heat transfer.
- Optional 2-speed indoor fan with VFD controller
- Standard factory-installed thermo-static expansion valve (TXV) with removable power element.
- Easy maintenance – removal of single panel allows access to virtually all components.
- Die-formed galvanized steel casings provide durability and structural integrity. Optional paint is available.
- 24-volt terminal block for control wiring connection.
- Hot water coil, steam coil, and electric heat accessories are available.

WARRANTY

- 1 Year parts limited warranty

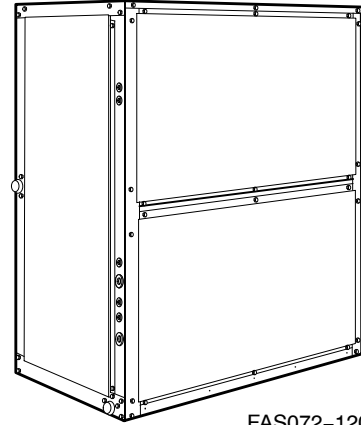

FAS072-120

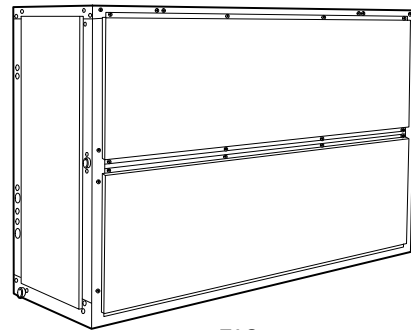

FAS150-300



Use of the AHRI Certified TM Mark indicates a manufacturer's participation in the program. For verification of certification for individual products, go to www.ahridirectory.org.



UNIT PERFORMANCE DATA				
UNIT	Nominal Tons	Number of Circuits	Unit Dimensions H x W x L [mm]	Unit Weight lb. [kg]
FAS072*AAA0A0A	6	1	56-1/16" x 49" x 28-3/16" [1424 x 1244 x 714]	399 [181]
FAS091*AAA0A0A	7 1/2	1	56-1/16" x 49" x 28-3/16" [1424 x 1244 x 714]	404 [183]
FAS120*AAA0A0A	10	2	56-1/16" x 49" x 28-3/16" [1424 x 1244 x 714]	425 [193]
FAS150*AAA0A0A	12 1/2	2	56-1/16" x 89" x 28-3/16" [1424 x 2261 x 714]	695 [315]
FAS180*AAA0A0A	15	2	56-1/16" x 89" x 28-3/16" [1424 x 2261 x 714]	713 [323]
FAS240*AAA0A0A	20	2	56-1/16" x 89" x 28-3/16" [1424 x 2261 x 714]	730 [331]
FAS300*AAA0A0A	25	2	65-9/16" x 100-1/2" x 32-5/8" [1665 x 2553 x 829]	1050 [477]

* Indicates Unit voltage: K = 208/230-1-60, H = 208/230-3-60, M = 208/230/460-3-60, L = 460-3-60, S = 575-3-60

NOTE: BASE MODEL NUMBERS LISTED. SEE MODEL NOMENCLATURE LISTING FOR ADDITIONAL OPTIONS

MODEL NUMBER NOMENCLATURE

MODEL SERIES	F	A	S	0	9	1	M	A	A	A	0	A	0	A
Position Number	1	2	3	4	5	6	7	8	9	10	11	12	13	14
F = R-410A Fan Coil Unit														
A = Air Conditioning (Cooling Only) Type														
S = Standard Efficiency Efficiency														
072 = 6 Tons (1 circuit) 091 = 7.5 Tons (1 circuit) 120 = 10 Tons (2 circuit) 150 = 12.5 Tons (2 circuit) 180 = 15 Tons (2 circuit) 240 = 20 Tons (2 circuit) 300 = 25 Tons (2 circuit) Nominal Tonnage														
K = 208/230-1-60 H = 208/230-3-60 M = 460/208/230-3-60 L = 460-3-60 S = 575-3-60 Voltage														
A = Standard Static Standard Efficiency Motor / Standard Drive B = High (Alternate) Static Standard Efficiency Motor / High Drive (072 & 091 Only) High (Alternate) Static High Efficiency / High Drive (150, 180, 240, 300 Only) D = Standard Static High Efficiency Motor / Standard Drive E = High (Alternate) Static High Efficiency Motor / High Drive Fan Motor Options* * See table below for Fan Motor Options														
A = Al/Cu Indoor Coil														
A = Future Use														
0 = Single Speed Indoor Fan Motor 2 = Two Speed Indoor Fan Motor Controller (VFD) Fan Speed Controller														
A = None - Standard - Unpainted B = Painted cabinet (Gray) Painted Cabinet Options														
0 = Future use Future Use														
A = Standard														

Notes:

- * All FAS072-150 units with a "6" voltage designation are triple voltage; ie., 208/230/460-3-60.
Size FAS180 is also triple voltage in the "6" configuration unless the High Static motor option is used that is discrete 460-3-60.
Units that require 2-speed indoor fan motor must use dedicated voltage models listed. The VFD used is not multi-voltage.
- ** 30 size models and single-phase 072 and 091 sizes designate standard motor and high static drive.

Position 8	Motor Description	Voltage	Unit Size						
			072	091	120	150	180	240	300
A	Std Static, Std Efficient Motor / Std Drive	All	✓	✓	✓	✓	✓	-	-
B	High (Alternate) Static, Std Efficient Motor / High Drive	575-3-60	✓	✓	✓	-	-	-	-
		208/230-1-60	✓	✓	-	-	-	-	-
		208/230-3-60 460-3-60	✓	✓	✓	✓	-	-	-
D	Std Static, High Efficient Motor / Std Drive	All	-	-	-	-	-	✓	✓
E	High (Alternate) Static, High Efficient Motor / High Drive	575-3-60	-	-	-	✓	✓	✓	✓
		208/230-3-60	-	-	-	-	✓	✓	✓
		460-3-60	-	-	-	-	✓	✓	✓

2- Speed Motors

Position 8	Motor Description	Voltage	Unit Size						
			072	091	120	150	180	240	300
A	Std Static, Std Efficient Motor / Std Drive	All	✓	✓	✓	✓	✓	-	-
	Std Static, High Efficient Motor / Std Drive	All	-	-	-	-	-	✓	✓
E	High (Alternate) Static, Std Efficient Motor / High Drive	575-3-60	✓	✓	✓	-	-	-	-
		208/230-3-60 460-3-60	✓	✓	✓	✓	-	-	-
	High (Alternate) Static, High Efficient Motor / High Drive	575-3-60	-	-	-	✓	✓	✓	✓
		208/230-3-60 460-3-60	-	-	-	-	✓	✓	✓

PHYSICAL DATA

UNIT FAS	072	091	120	150	180	240	300
NOMINAL CAPACITY (Tons)	6	7 ¹ / ₂	10	12 ¹ / ₂	15	20	25
OPERATING WEIGHT (lb)							
Base Unit with TXV (4 Row)	399	404	425	695	713	730	1050
Plenum	175	175	175	225	225	225	325
Economizer	185	185	185	340	340	340	340
Hot Water Coil	195	195	195	285	285	285	345
Steam Coil	215	215	215	340	340	340	405
FANS							
Qty...Diam. (in.)	1...15	1...15	1...15	2...15	2...15	2...15	2...18
Nominal Airflow (cfm)	2400	3000	4000	5000	6000	8000	10,000
Airflow Range (cfm)	1800-3000	2250-3750	3000-5000	3750-6250	4500-7500	6000-10,000	7500-12,500
Nom. Motor Hp (Standard Motor)*							
208/230-1-60	1.3	2.4	—	—	—	—	—
208/230-3-60 and 460-3-60	2.4	2.4	2.4	2.9	3.7	5.0	7.5
575-3-60	1.0	2.0	2.0	3.0	3.0	5.0	7.5
Motor Speed (rpm)							
208/230-1-60	1725	1725	—	—	—	—	—
208/230-3-60 and 460-3-60	1725	1725	1725	1725	1725	1760	1760
575-3-60	1725	1725	1725	1725	1725	1745	1755
REFRIGERANT	R-410A						
Shipping charge (lb)	Nitrogen Purge						
Metering Device	TXV						
Operating charge (lb) (approx per circuit) †	3.0	3.0	1.5/1.5	2.0/2.0	2.5/2.5	3.5/3.5	4.5/4.5
DIRECT-EXPANSION COIL	Enhanced Copper Tubes, Aluminum Sine-Wave Fins						
Max Working Pressure (psig)	650						
Material	Al / Cu						
Coil Type	RTPF						
Face Area (sq ft)	6.67	8.33	10.01	13.25	17.67	19.88	24.86
No. of Splits	1	1	2	2	2	2	2
Split Type...Percentage	Face...50/50						
No. of Circuits per Split	12	15	9	12	16	18	20
Rows...Fins/in.	4...15	4...15	4...15	4...15	4...15	4...15	4...15
STEAM COIL							
Max Working Press. (psig at 260°F)	20						
Total Face Area (sq ft)	6.67	6.67	6.67	13.33	13.33	13.33	15.0
Rows...Fins/in.	1...9	1...9	1...9	1...10	1...10	1...10	1...10
HOT WATER COIL							
Max Working Pressure (psig)	150						
Total Face Area (sq ft)	6.67	6.67	6.67	13.33	13.33	13.33	15.0
Rows...Fins/in.	2...8.5	2...8.5	2...8.5	2...8.5	2...8.5	2...8.5	2...12.5
Water Volume							
(gal)				13.9			14.3
(ft ³)				1.85			1.90
PIPING CONNECTIONS							
Quantity...Size (in.)							
DX Coil — Suction (ODF)	1...1 ¹ / ₈	1...1 ¹ / ₈	2...1 ¹ / ₈	2...1 ¹ / ₈	2...1 ¹ / ₈	2...1 ¹ / ₈	2...1 ³ / ₈
DX Coil — Liquid Refrig. (ODF)	1... ⁵ / ₈		2... ⁵ / ₈				
Steam Coil, In (MPT)	1...2 ¹ / ₂				1...2 ¹ / ₂		
Steam Coil, Out (MPT)	1...1 ¹ / ₂				1...1 ¹ / ₂		
Hot Water Coil, In (MPT)	1...1 ¹ / ₂		1...1 ¹ / ₂		1...2		
Hot Water Coil, Out (MPT)	1...1 ¹ / ₂		1...1 ¹ / ₂		1...2		
Condensate (PVC)	1...5/8 ODM / 1 1/4 IDF						
FILTERS	Throwaway — Factory-Supplied						
Quantity...Size (in.)	4...16 x 24 x 2			4...16 x 20 x 2			4...20 x 24 x 2
Access Location				4...16 x 24 x 2			4...20 x 25 x 2
	Right or Left Side						

* Refer to Alternate Fan Motor Data table for alternate motor data.

† Units are shipped without refrigerant charge.

OPTIONS AND ACCESSORIES

ITEM	OPTION*	ACCESSORY †
Alternate Fan Motors	X	
Alternate Drives	X	
2-Speed Indoor Fan Motor System	X	
CO ₂ Sensors		X
Condensate Drain Trap		X
Discharge Plenum		X
Economizer Ultra LOW LEAK-FDD		X
Economizer Standard Leak		X
Electric Heat		X
Hot Water Heating Coils		X
Overhead Suspension Package		X
Prepainted Units	X	
Return Air Grille		X
Steam Heating Coil		X
Subbase		X

* Factory-installed option.

† Field-installed accessory

Factory-installed options

Alternate fan motors and drives are available to provide the widest possible range of performance.

Prepainted steel units are available from the factory for applications that require painted units. Units are painted with American Sterling Gray color.

2-Speed Indoor Fan Motor system saves energy and installation time by utilizing a Variable Frequency Drive (VFD) to automatically adjust the indoor fan motor speed in sequence with the units cooling operation. Per ASHRAE 90.1 2010 standard section 6.4.3.10.b, during the first stage of cooling operation the VFD will adjust the fan motor to provide 2/3rd of the total cfm established for the unit. When a call for the second stage of cooling is required, the VFD will allow the total cfm for the unit established (100%). During the heating mode the VFD will allow total design cfm (100%) operation and during the ventilation mode the VFD will allow operation to 2/3rd of total cfm.

Compared to single speed indoor fan motor systems, ICP's 2-Speed Indoor Fan Motor system can save substantial energy, 25%+*, versus single speed indoor fan motor systems.

*Data based on .10 (\$/kWh) in an office application utilizing ICP's HAP 4.6 simulation software program.

The VFD used in ICP's 2-Speed Indoor Fan Motor system has soft start capabilities to slowly ramp up the speeds, thus eliminating any high inrush air volume during initial start-up. It also has internal over current protection for the fan motor and a field installed display kit that allows adjustment and in depth diagnostics of the VFD.

This 2-Speed Indoor Fan Motor system is available on models with 2-stage cooling operation with electrical mechanical controls.

The 2-Speed Indoor Fan Motor system is very flexible for initial fan performance set up and adjustment. The standard factory shipped VFD is pre-programmed to automatically stage the fan speed between the first and second stage of cooling. The unit fan performance static pressure and cfm can be easily adjusted using the traditional means of pulley adjustments. The other means to adjust the unit static and cfm performance is

to utilize the field installed Display Kit and adjust the frequency and voltage in the VFD to required performance requirements. In either case, once set up, the VFD will automatically adjust the speed between the cooling stage operations.

Field-installed accessories

Two-row hot water coils have copper tubes mechanically bonded to aluminum plate fins and non-ferrous headers.

One-row steam coil has copper tubes and aluminum fins. The Inner Distributing Tube (IDT) design provides uniform temperatures across the coil face. The steam coil has a broad operating pressure range; up to 20 psi (138 kPag) at 260°F (126°C). The IDT steam coils are especially suited to applications where sub-freezing air enters the unit.

Electric resistance heat coils have an open-wire design and are mounted in a rigid frame. Safety cutouts for high temperature conditions are standard. Terminal block for single-point power connection is included.

Economizers – temperature dry bulb controlled –

Ultra LOW LEAK – EconoMi\$er X with solid-state W7220 controller, gear-driven, modulating damper, spring return actuator. Supply and outdoor air sensors, and CO₂ sensor compatible, for use in electro mechanical controls only. Also includes return and outside air damper leakage that meets California Title 24 section 140.4 requirements. Controller meets California Title 24 Section 120.2 Fault Detection and Diagnostic (FDD) requirements.

STANDARD – EconoMi\$er IV – with gear driven damper blades and W7212 controller (Use --HH--57AC-078 for enthalpy control).

Discharge plenum directs the air discharge directly into the occupied space; integral horizontal and vertical louvers enable redirection of airflow. Accessory is available unpainted or painted. Field assembly is required (only applicable for vertical application).

Return-air grille provides a protective barrier over the return-air opening and gives a finished appearance to units installed in the occupied space. Accessory is available unpainted or painted.

Subbase provides a stable, raised platform and room for condensate drain trap connection for vertical floor-mounted units. Accessory is available unpainted or painted.

Overhead suspension package includes necessary brackets to support units in horizontal ceiling installations.

CO₂ sensors can be used in conjunction with the economizer accessory to help meet indoor air quality requirements. The sensor signals the economizer to open when the CO₂ level in the space exceeds the set point. A programmable thermostat can be used to override the sensor if the outside-air temperature is too high or too low.

Condensate drain trap includes an overflow shutoff switch that can be wired to turn off the unit if the trap becomes plugged. Kit also includes a wire harness that can be connected to an alarm if desired. The transparent trap is designed for easy service and maintenance.

ACCESSORY HEATERS			
HEATER PART NO.	DESCRIPTION	NOMINAL CAPACITY	USED WITH
(240V – 3 PHASE – 60 HZ)			
CAELHEAT001A00	5.0 kW, 240–3–60	5	072, 091, 120
CAELHEAT004A00	10.0 kW, 240–3–60	10	072, 091, 120
CAELHEAT007A00	15.0 kW, 240–3–60	15	072, 091, 120
CAELHEAT010A00	25.0 kW, 240–3–60	25	072, 091, 120
CAELHEAT013A00	35.0 kW, 240–3–60	35	091, 120
CAELHEAT016A00	10.0 kW, 240–3–60	10	180, 240
CAELHEAT019A00	20.0 kW, 240–3–60	20	180, 240
CAELHEAT022A00	30.0 kW, 240–3–60	30	180, 240
CAELHEAT025A00	50.0 kW, 240–3–60	50	180, 240
CAELHEAT028A00	20.0 kW, 240–3–60	20	300
CAELHEAT031A00	40.0 kW, 240–3–60	40	300
CAELHEAT034A00	50.0 kW, 240–3–60	50	300
CAELHEAT037A00	70.0 kW, 240–3–60	70	300
(480V – 3 PHASE – 60 HZ)			
CAELHEAT002A00	5.0 kW, 480–3–60	5	072, 091, 120
CAELHEAT005A00	10.0 kW, 480–3–60	10	072, 091, 120
CAELHEAT008A00	15.0 kW, 480–3–60	15	072, 091, 120
CAELHEAT011A00	25.0 kW, 480–3–60	25	072, 091, 120
CAELHEAT014A00	35.0 kW, 480–3–60	35	091, 120
CAELHEAT017A00	10.0 kW, 480–3–60 and 7.0 kW, 400–3–50 Electric Heater	10	180, 240
CAELHEAT020A00	20.0 kW, 480–3–60 and 15.0 kW, 400–3–50 Electric Heater	20	180, 240
CAELHEAT023A00	30.0 kW, 480–3–60 and 21.0 kW, 400–3–50 Electric Heater	30	180, 240
CAELHEAT026A00	50.0 kW, 480–3–60 and 35.0 kW, 400–3–50 Electric Heater	50	180, 240
CAELHEAT028A00	20.0 kW, 480–3–60	20	300
CAELHEAT031A00	40.0 kW, 480–3–60	40	300
CAELHEAT034A00	50.0 kW, 480–3–60	50	300
CAELHEAT037A00	70.0 kW, 480–3–60	70	300
(575V – 3 PHASE – 60 HZ)			
CAELHEAT003A00	5.0 kW, 575–3–60	5	072, 091, 120
CAELHEAT006A00	10.0 kW, 575–3–60	10	072, 091, 120
CAELHEAT009A00	15.0 kW, 575–3–60	15	072, 091, 120
CAELHEAT012A00	25.0 kW, 575–3–60	25	072, 091, 120
CAELHEAT015A00	35.0 kW, 575–3–60	35	091, 120
CAELHEAT015A00	10.0 kW, 575–3–60	10	180, 240
CAELHEAT021A00	20.0 kW, 575–3–60	20	180, 240
CAELHEAT024A00	30.0 kW, 575–3–60	30	180, 240
CAELHEAT027A00	50.0 kW, 575–3–60	50	180, 240
CAELHEAT030A00	20.0 kW, 480–3–60	20	300
CAELHEAT033A00	40.0 kW, 480–3–60	40	300
CAELHEAT036A00	50.0 kW, 480–3–60	50	300
CAELHEAT039A00	70.0 kW, 480–3–60	70	300

* Electric heaters tested at a maximum ESP of 1.9"

NOTE: App. Shipping weight for AAHC05AHA/CAELHEATER001A00–35CSA/015A00 is 55 lbs. each
App. Shipping weight for AAHC10BHA/CAELHEAT016A00 – 027A00 is 60 lbs. each
App. Shipping weight for AACH20EHC/ CAELHEAT028A00 – 039 is 75 lbs. each

ACCESSORIES		
PART NO.	DESCRIPTION	USED WITH
CAECOMZR001B00	Economizer --- temperature dry bulb controlled - Standard Leak design with gear driven damper blades and W7212 controller ‡ (Use --HH--57AC-078 for enthalpy control)	072-120
CAECOMZR008A00	Economizer - temperature dry bulb controlled - Ultra LOW LEAK - EconoMi\$er X with solid-state W7220 controller, gear-driven, modulating damper, spring return actuator. Supply and outdoor air sensors, and CO2 sensor compatible, for use in electro mechanical controls only. Also includes return and outside air damper leakage that meets Title 24 section 140.4 requirements. Controller meets California Title 24 Section 120.2 Fault Detection and Diagnostic (FDD) requirements.	072-120
--HH--57AC-081	Enthalpy Control for W7220 Controller only, (One required for single enthalpy, two required for different enthalpy) Only available through Micrometl.	072-120
--HH--57AC-078	Enthalpy control upgrade. Only available through Micrometl.	072-120
AHWC01AAA CAHWCOIL001A00	Hot Water Coil (2 row)	072-120
ACSC01AA CAOVRFLW001A00	Condensate Overflow Switch Assembly	072-120
APDC01AAA CAPLENUM001A00	Discharge Plenum	072-120
APDC01AAA CAPLENUM004A00	Discharge Plenum - Painted	072-120
AGRC01AAA CARAGRIL001A00	Return Air Grille	072-120
AGRPC01AAA CARAGRIL004A00	Return Air Grille - Painted	072-120
ASPC01AAA CASTCOIL001A00	Steam Coil (1 row)	072-120
CASUBASE001A00	Floor Mount Base (Subbase)	072-120
ASBPC01AA CASUBASE003A00	Floor Mount Base (Subbase) - Painted	072-120
AHBC01AA CASUSPEN001A00	Overhead Suspension Brackets	072-120
CAECOMZR010A00	Economizer - temperature dry bulb controlled - Ultra LOW LEAK - EconoMi\$er X with solid-state W7220 controller, gear-driven, modulating damper, spring return actuator. Supply and outdoor air sensors, and CO2 sensor compatible, for use in electro mechanical controls only. Also includes return and outside air damper leakage that meets Title 24 section 140.4 requirements. Controller meets California Title 24 Section 120.2 Fault Detection and Diagnostic (FDD) requirements.	150 - 240
CAECOMZR002B00	Economizer --- temperature dry bulb Enthalpy Controlled Standard Leak design with gear driven damper blades and W7212 controller ‡ (Use --HH--57AC-078 for enthalpy control)	150 - 240
--HH--57AC-081	Enthalpy Control for W7220 Controller only, (One required for single enthalpy, two required for different enthalpy) Only available through Micrometl.	150 - 240
--HH--57AC-078	Enthalpy control upgrade. Only available through Micrometl.	150 - 240
AHWC02BAA CAHWCOIL002A00	Hot Water Coil (2 row)	150 - 240
ACSC01AA CAOVRFLW001A00	Condensate Overflow Switch Assembly	150 - 240
APDC02BAA CAPLENUM002A00	Discharge Plenum	150 - 240
APDC02BAA CAPLENUM005A00	Discharge Plenum - Painted	150 - 240
AGRC02BAA CARAGRIL002A00	Return Air Grille	150 - 240
AGRPC02BAA CARAGRIL005A00	Return Air Grille - Painted	150 - 240
ASPC02BAA CASTCOIL002A00	Steam Coil (1 row)	150 - 240
CASUBASE001A00	Floor Mount Base (Subbase)	150 - 240
ASBPC01AA CASUBASE003A00	Floor Mount Base (Subbase) - Painted	150 - 240

ACCESSORIES		
PART NO.	DESCRIPTION	USED WITH
AHBC01AA CASUSPEN001A00	Overhead Suspension Brackets	150 – 240
† Discharge plenums are shipped knocked down and require field assembly. Cannot be used with electric heat, or horizontal applications.		
‡ This accessory replaces CAECOMZR001A00 which used a linkage damper blade design and W7459 controller. The CAECOMZR001A00 can be used if inventory is available as there is no price change between the two.		
CAECOMZR003B00	Economizer — temperature dry bulb Enthalpy Controlled Standard Leak design with gear driven damper blades and W7212 controller ‡ (Use --HH--57AC-078 for enthalpy control)	300
CAECOMZR012A00	Economizer – temperature dry bulb controlled – Ultra LOW LEAK – EconoMi\$er X with solid-state W7220 controller, gear-driven, modulating damper, spring return actuator. Supply and outdoor air sensors, and CO2 sensor compatible, for use in electro mechanical controls only. Also includes return and outside air damper leakage that meets Title 24 section 140.4 requirements. Controller meets California Title 24 Section 120.2 Fault Detection and Diagnostic (FDD) requirements.	300
--HH--57AC-081	Enthalpy Control for W7220 Controller only, (One required for single enthalpy, two required for different enthalpy). Only available through Micrometl.	300
--HH--57AC-078	Enthalpy control upgrade. Only available through Micrometl.	300
AHWCOIL003A00	Hot Water Coil (2 row)	300
ACSC01AA CAOVRFLW001A00	Condensate Overflow Switch Assembly	300
CAPLENUM003A00	Discharge Plenum	300
CAPLENUM006A00	Discharge Plenum – Painted	300
CARAGRIL003A00	Return Air Grille	300
CARAGRIL006A00	Return Air Grille – Painted	300
CASTCOIL003A00	Steam Coil (1 row)	300
CASUBASE002A00	Floor Mount Base (Subbase)	300
CASUBASE004A00	Floor Mount Base (Subbase) – Painted	300
AHBC01AA CASUSPEN001A00	Overhead Suspension Brackets	300
NOTE: Accessories are unpainted unless noted otherwise in the decription.		
‡ This accessory replaces CAECOMZR001A00 which used a linkage damper blade design and W7459 controller. The CAECOMZR001A00 can be used if inventory is available as there is no price change between the two.		

ACCESSORIES			
ACCESSORIES: 2-SPEED (VFD) DISPLAY KIT			
PART NO.	DESCRIPTION	SHIPPING WT. (LBS)	USED WITH
CRDISKIT001A00	2 Speed VFD display kit - Provides the field capability to set up points and troubleshooting codes on the VFD controller. Kit includes display and cable. If preferred, kit can be used for any associated unit with VFD.	4	All 2 Speed VFD Controllers
ACCESSORIES: RELAY PACKAGE			
CATRANRY001A00	Transformer Relay Package - Contains 200/230/460 to 24-volt transformer, indoor fan and solenoid valve relays with wiring and quick connect terminals. Formerly 38AE-900---001.	4	Recommended for 24-volt thermostat applications when additional VA is required.

OPTIONS AND ACCESSORIES (cont.)

FAS WITH DISCHARGE PLENUM, RETURN AIR GRILLE AND SUBBASE

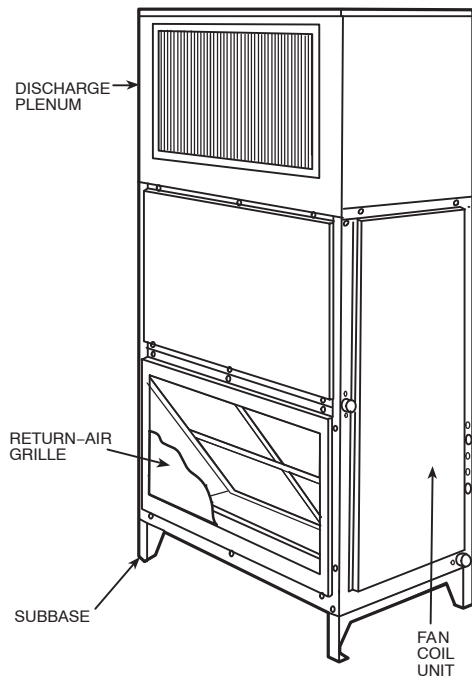

FAS WITH HOT WATER OR STEAM COIL

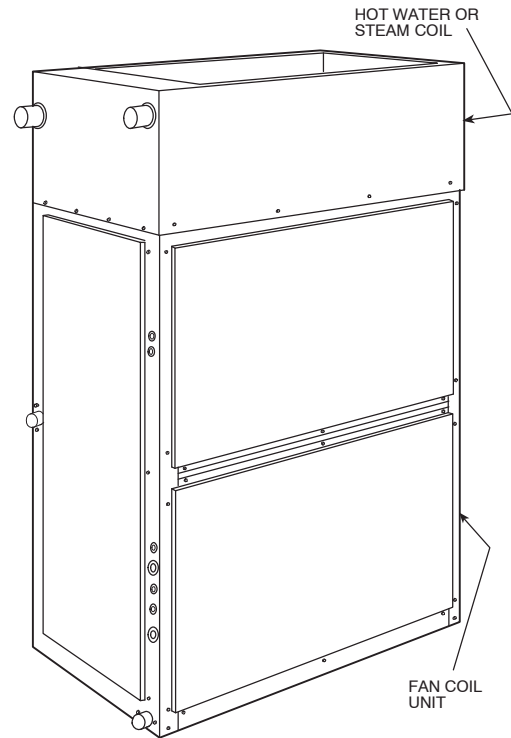

FAS WITH ECONOMIZER

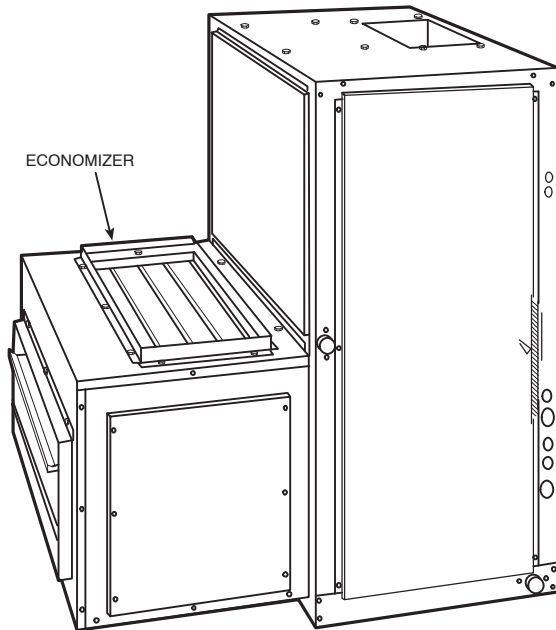

FAS WITH CONDENSATE TRAP

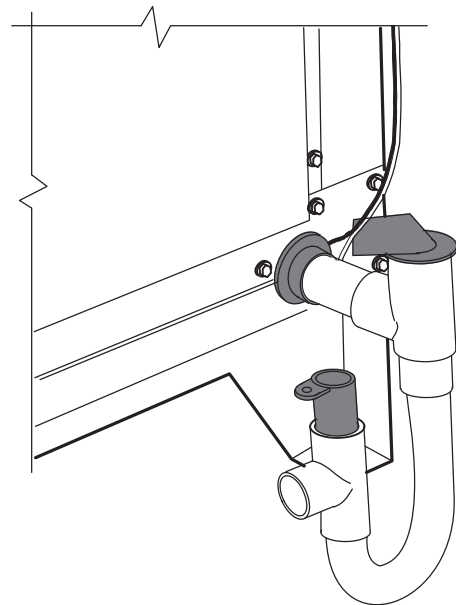

DIMENSIONS

- NOTES:
1. DIMENSIONS IN () ARE IN MILLIMETERS.
 2. DIRECTIONS OF AIRFLOW.
 3. RECOMMENDED CLEARANCE:
 4. LIQUID PIPING NOT SUPPLIED BY CARRIER.
 5. DUCT FLANGE IS FACTORY SUPPLIED AND FIELD INSTALLED.

ACCESSORY	SEE DRAWING
DISCHARGE PLENUM	40RM500996
ECONOMIZER	40RM500999
STEAM COIL	40RM500999
HOT WATER COIL	40RM500999
RETURN AIR GRILLE	40RM500996
OVERHEAD SUSPENSION	40RM500996
SUBBASE	40RM500996
ELECTRIC HEAT	40RM501002

UNRELEASED DATA

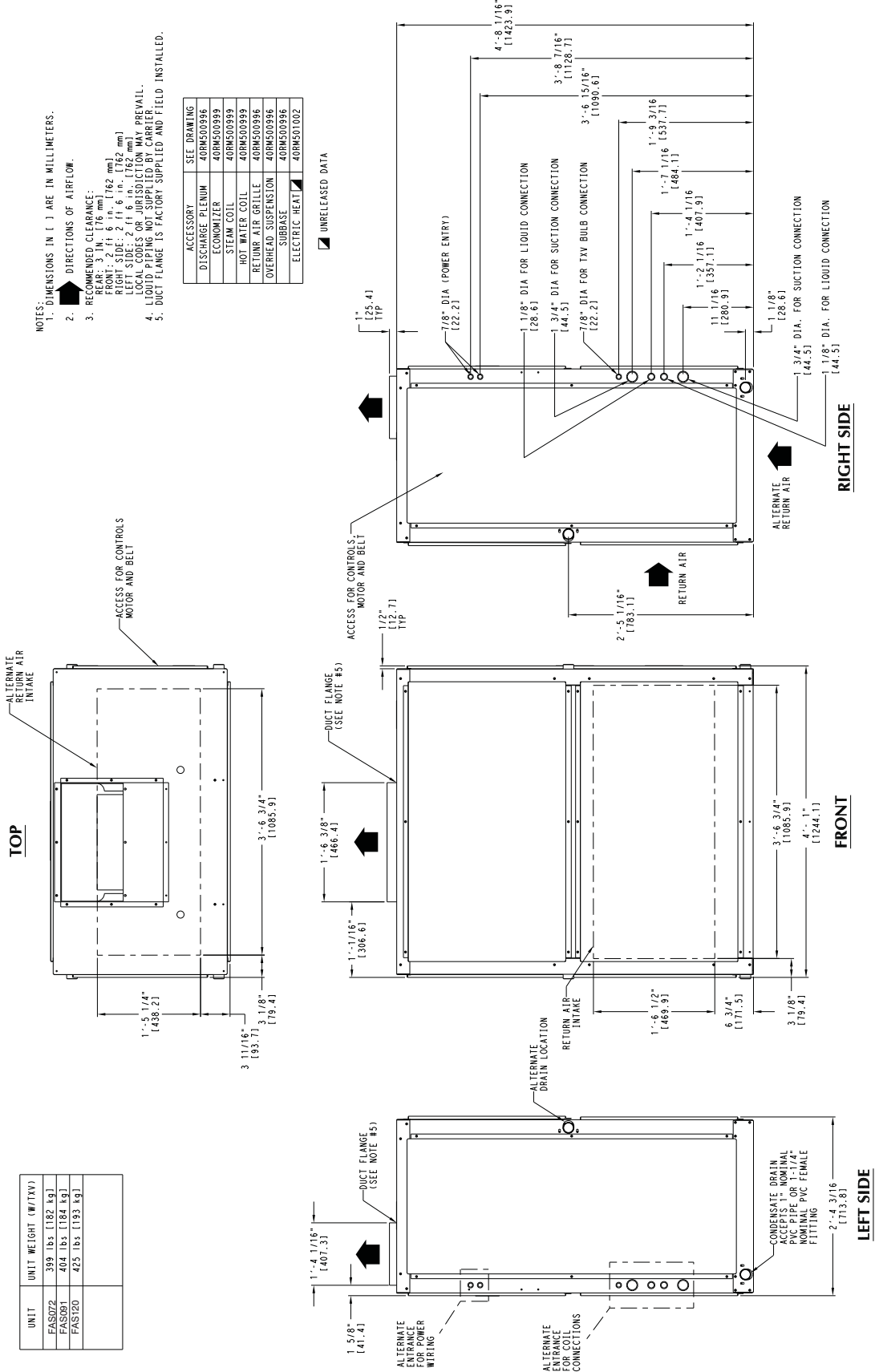

UNIT	UNIT WEIGHT (W/TXV)
FAS072	399 lbs. [182 kg]
FAS091	404 lbs. [184 kg]
FAS120	425 lbs. [193 kg]

FAS072-120

Specifications subject to change without notice.

C160026

508 71 1603 01

DIMENSIONS (cont.)

NOTES:
1. DIMENSIONS IN () ARE IN MILLIMETERS.

- DIRECTIONS OF AIRFLOW.
- RECOMMENDED CLEARANCE: 2" (51 mm)
- RIGHT SIDE: 2" (51 mm) FRONT; 2" (51 mm) IN; 1 1/2" (38 mm) SIDE; 2" (51 mm) TOP; 2" (51 mm) BOTTOM. LOCAL CODES OR JURISDICTION MAY PREVAIL. LIQUID PIPING NOT SUPPLIED BY CARRIER.
- DUCT FLANGE IS FACTORY SUPPLIED AND FIELD INSTALLED.

ACCESSORY	SEE DRAWING
DISCHARGE PLENUM	40RMS00997
ECONOMIZER	40RMS01000
STEAM COIL	40RMS01000
HOT WATER COIL	40RMS01000
RETURN AIR GRILLE	40RMS00997
OVERHEAD SUSPENSION	40RMS00997
SUBBASE	40RMS00997
ELECTRIC HEAT	40RMS01002

UNRELEASED DATA

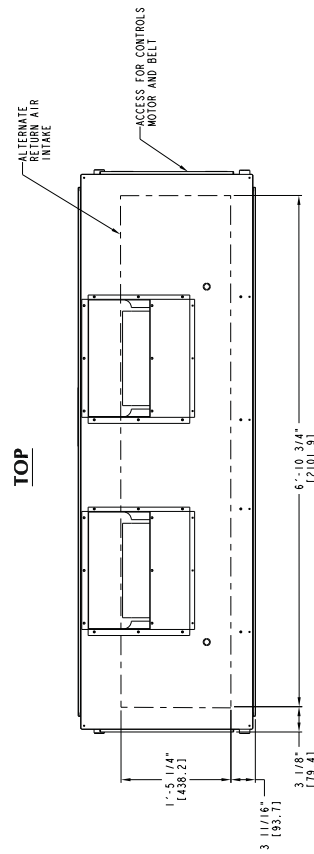

UNIT	UNIT WEIGHT (W/TXV)
FAS180	713 lbs. [323 kg]
FAS240	730 lbs. [331 kg]
FHS180	713 lbs. [323 kg]
FHS240	720 lbs. [327 kg]

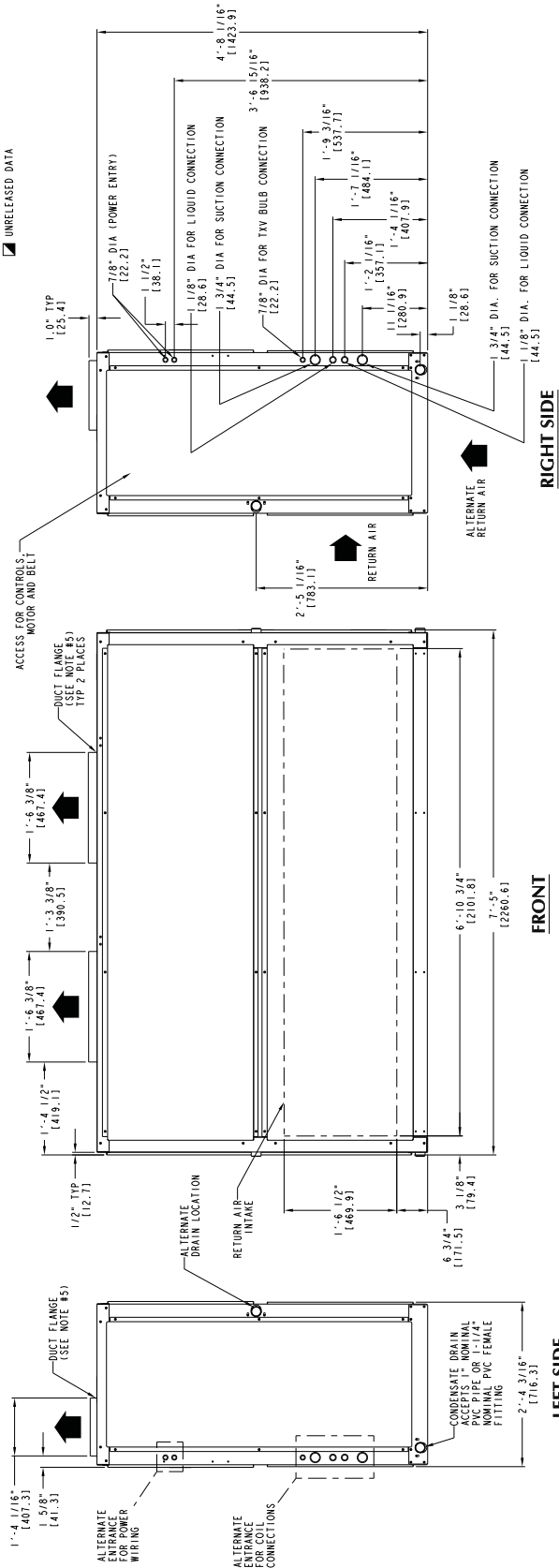

FAS180 - 240

DIMENSIONS (cont.)

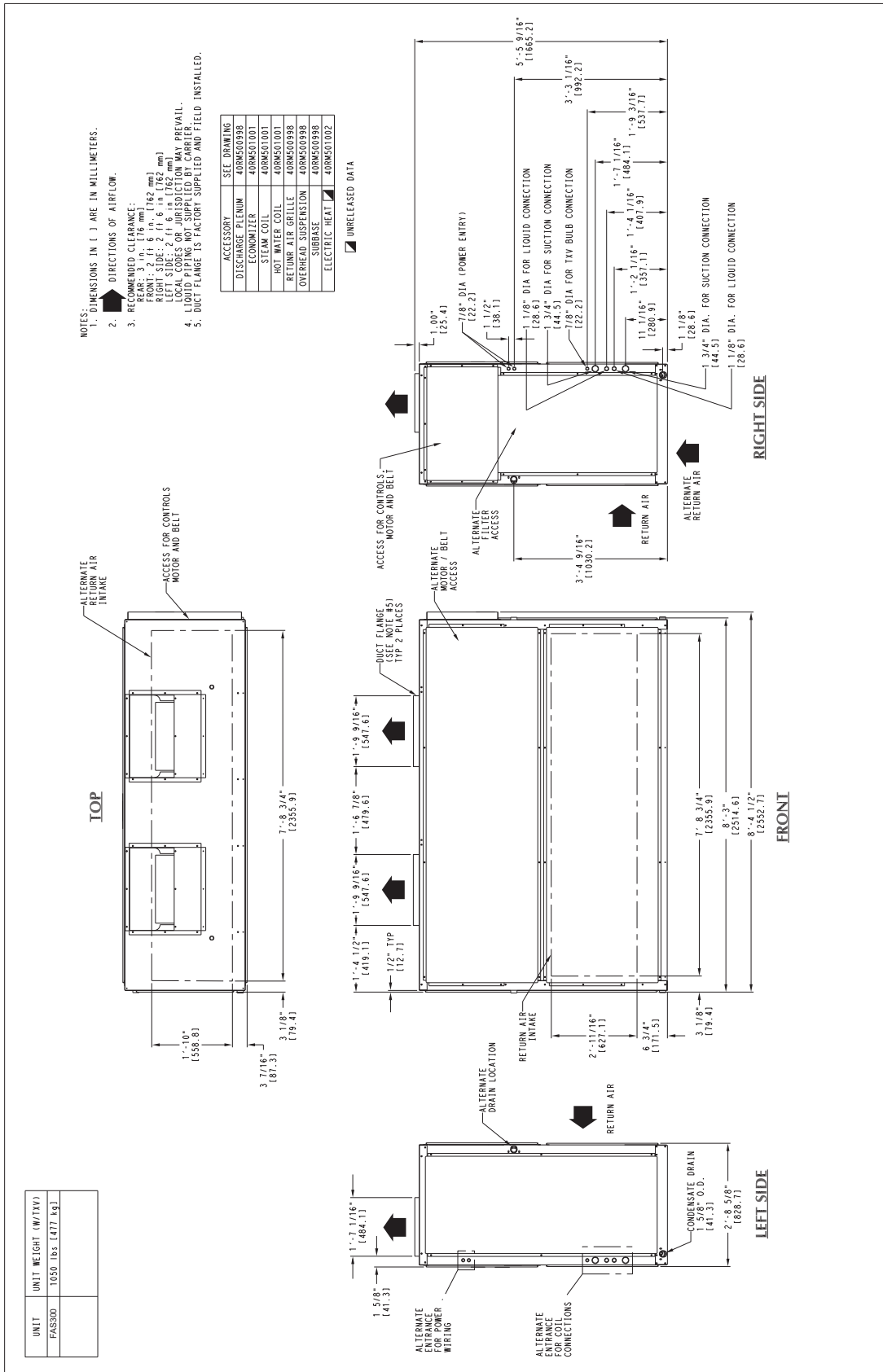

FAS300

DIMENSIONS (cont.)

CORNER WEIGHTS HORIZONTAL POSITION

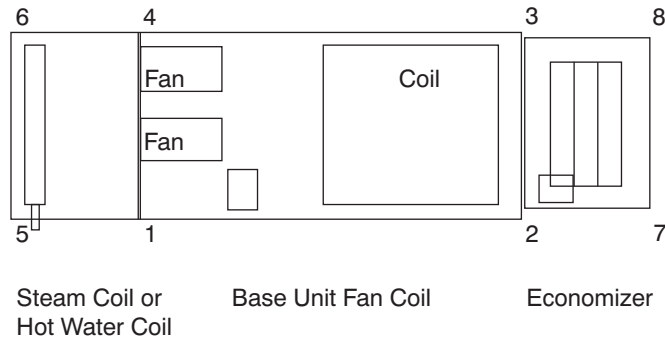

C09039

FAS - Horizontal Position

FAS UNIT	UNIT OR ACCESSORY NAME		UNIT OR ACCESSORY WEIGHT (lb)	CORNER NUMBER (WEIGHT IN LB)							
				1	2	3	4	5	6	7	8
072	FAN COIL BASE UNIT		399	109.3	106.1	90.6	93.4	—	—	—	—
091	FAN COIL BASE UNIT		404	110.7	107.5	91.7	94.5	—	—	—	—
120	FAN COIL BASE UNIT		425	116.4	113.0	96.5	99.4	—	—	—	—
072 - 120	STEAM COIL	ADD	215	40.2	0.0	0.0	40.6	66.5	67.5	0.0	0.0
	HOT WATER COIL	ADD	195	35.9	0.0	0.0	36.7	60.4	62.0	0.0	0.0
	ECONOMIZER	ADD	185	0.0	36.8	35.7	0.0	0.0	0.0	56.8	55.1
	ECO + STEAM COIL	ADD	400	38.8	38.6	37.4	39.2	64.2	65.2	59.5	57.7
	ECO + HW COIL	ADD	380	36.9	35.8	34.6	37.7	62.1	63.8	55.1	53.4
150	FAN COIL BASE UNIT		695	224.0	177.7	129.8	163.7	—	—	—	—
180	FAN COIL BASE UNIT		713	229.8	182.3	133.2	167.9	—	—	—	—
300	FAN COIL BASE UNIT		730	235.6	186.4	136.5	171.5	—	—	—	—
150 - 300	STEAM COIL	ADD	340	61.4	0.0	0.0	62.0	107.8	108.8	0.0	0.0
	HOT WATER COIL	ADD	285	51.7	0.0	0.0	51.3	91.5	90.6	0.0	0.0
	ECONOMIZER	ADD	340	0.0	66.9	62.0	0.0	0.0	0.0	109.8	102.0
	ECO + STEAM COIL	ADD	680	64.4	63.7	59.0	65.0	113.0	114.1	104.5	97.1
	ECO + HW COIL	ADD	625	60.0	57.6	53.4	59.5	106.2	105.1	94.6	87.8
300	FAN COIL BASE UNIT		1050	338.4	268.5	196.1	247.2	—	—	—	—
	STEAM COIL	ADD	405	73.2	0.0	0.0	73.8	128.4	129.6	0.0	0.0
	HOT WATER COIL	ADD	345	62.6	0.0	0.0	62.1	110.7	109.6	0.0	0.0
	ECONOMIZER	ADD	450	0.0	88.5	82.0	0.0	0.0	0.0	145.3	134.2
	ECO + STEAM COIL	ADD	855	80.6	80.1	74.1	81.6	142.0	143.4	131.3	122
	ECO + HW COIL	ADD	795	76.8	73.7	68.2	75.7	135.0	133.6	120.3	111.7

LEGEND:

ECO - Economizer

HW - Hot Water

DIMENSIONS (cont.)

CORNER WEIGHTS VERTICAL POSITION

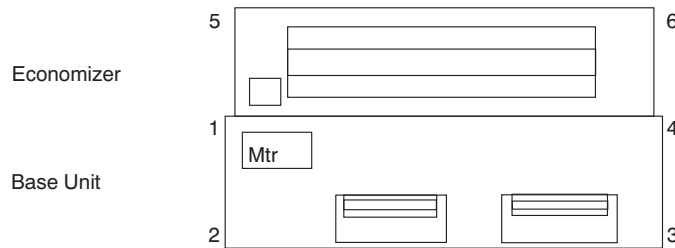

NOTE: Steam, Hot Water & Plenum
on top of positions 1,2,3,4

C09040

FAS – Vertical Position

FAS UNIT	UNIT OR ACCESSORY NAME		UNIT OR ACCESSORY WEIGHT (lb)	CORNER NUMBER (WEIGHT IN LB)					
				1	2	3	4	5	6
072	FAN COIL BASE UNIT		399	100.5	114.9	98.0	85.8	—	—
091	FAN COIL BASE UNIT		404	101.7	116.3	99.1	86.9	—	—
120	FAN COIL BASE UNIT		425	107.6	122.3	108.0	87.1	—	—
072, 091, 120	STEAM COIL	ADD	215	54.1	54.1	53.4	53.4	0.0	0.0
	HOT WATER COIL	ADD	195	49.4	49.4	48.1	48.1	0.0	0.0
	PLENUM	ADD	175	50.8	36.7	36.7	50.8	0.0	0.0
	ECONOMIZER	ADD	195	38.9	0.0	0.0	37.1	59.9	58.3
	ECO + STEAM COIL	ADD	410	93.0	53.4	52.6	91.1	61.0	59.1
	ECO + HW COIL	ADD	390	88.9	52.3	50.9	86.5	56.7	54.9
150	FAN COIL BASE UNIT		695	191.2	210.5	153.8	139.5	—	—
180	FAN COIL BASE UNIT		713	196.2	216.0	157.8	143.1	—	—
180	FAN COIL BASE UNIT		677	186.3	205.1	149.8	135.8	—	—
150, 180	STEAM COIL	ADD	340	85.4	85.4	84.6	84.6	0.0	0.0
	HOT WATER COIL	ADD	285	70.9	70.9	71.6	71.6	0.0	0.0
	PLENUM	ADD	225	72.5	40.0	40.0	72.5	0.0	0.0
	ECONOMIZER	ADD	340	66.5	0.0	0.0	62.0	109.5	102.0
	ECO + STEAM COIL	ADD	680	153.0	89.1	88.7	147.7	104.5	97.0
	ECO + HW COIL	ADD	625	139.9	82.5	83.3	136.7	94.7	87.9

LEGEND:

ECO – Economizer

HW – Hot Water

DIMENSIONS (cont.)

OVERHEAD SUSPENSION ACCESSORY

UNIT SIZES 072-120
(FRONT)

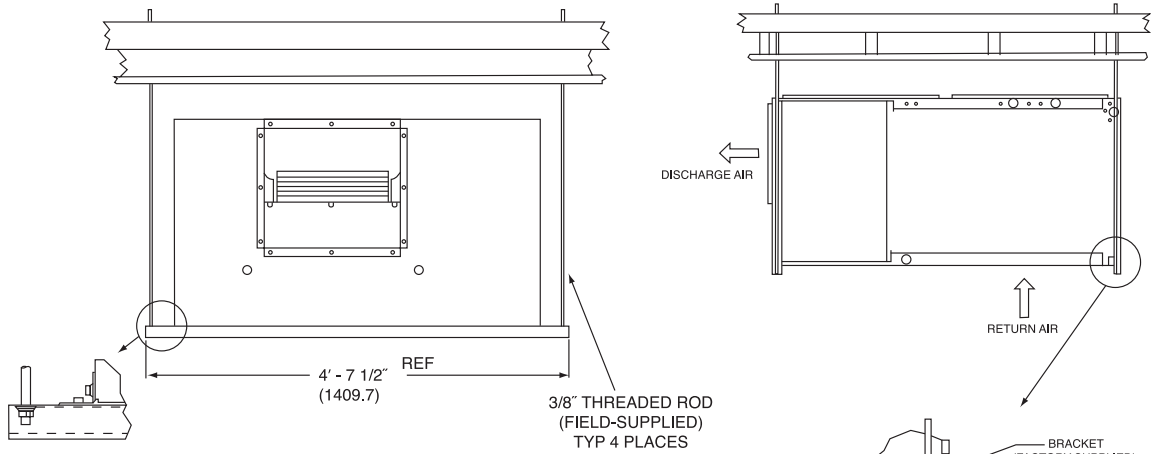

UNIT SIZES 150-240
(FRONT)

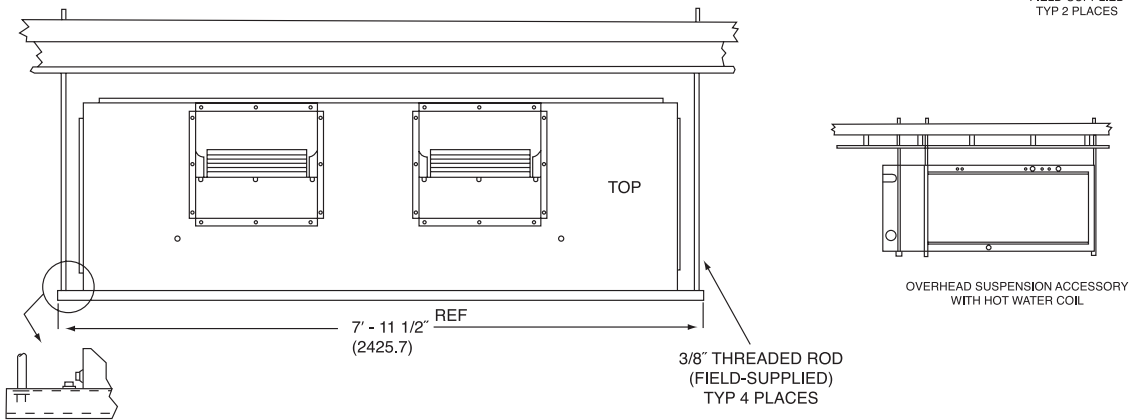

UNIT SIZES 300
(FRONT)

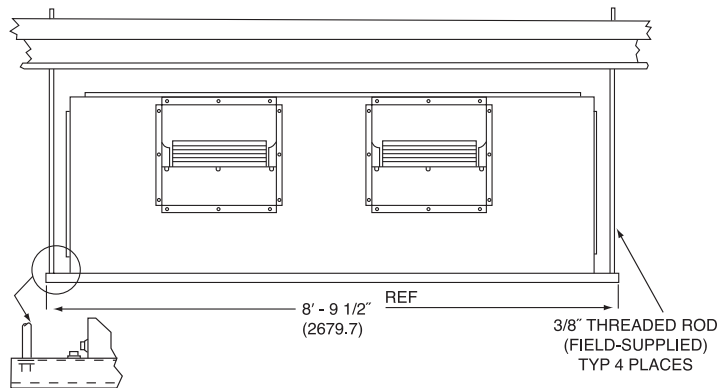

NOTE: Dimensions in [] are millimeters.

DIMENSIONS (cont.)

PLENUM, RETURN-AIR GRILLE, AND SUBBASE ACCESSORIES

UNIT SIZES 072-120

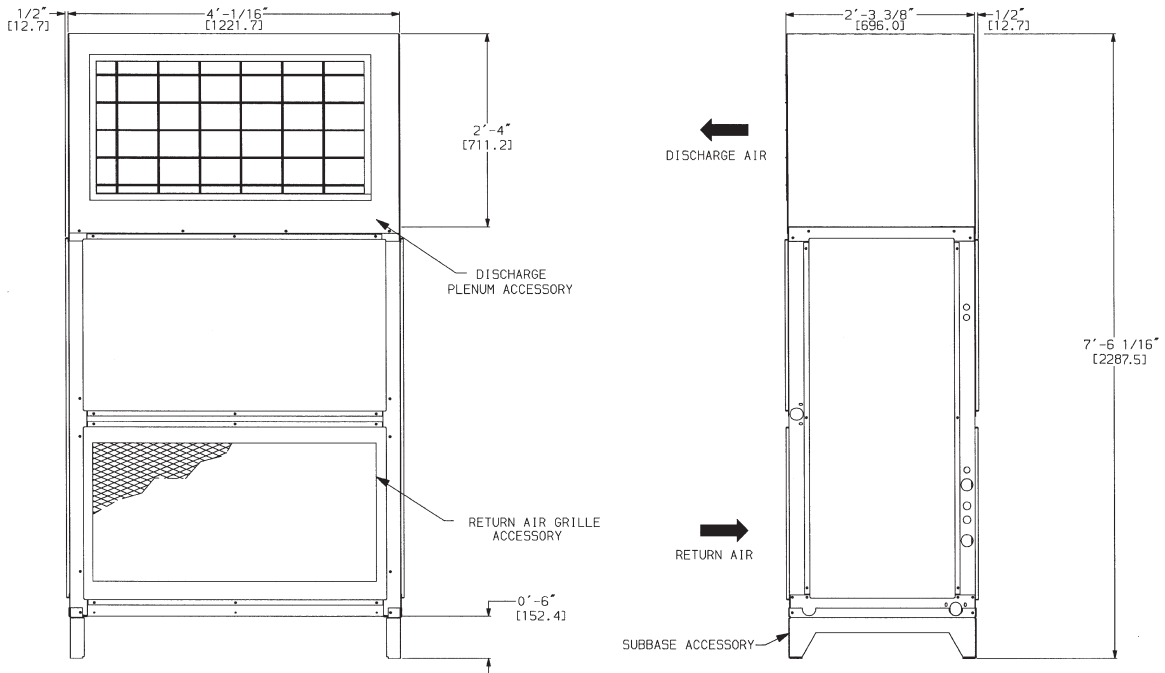

UNIT SIZE 150 - 240

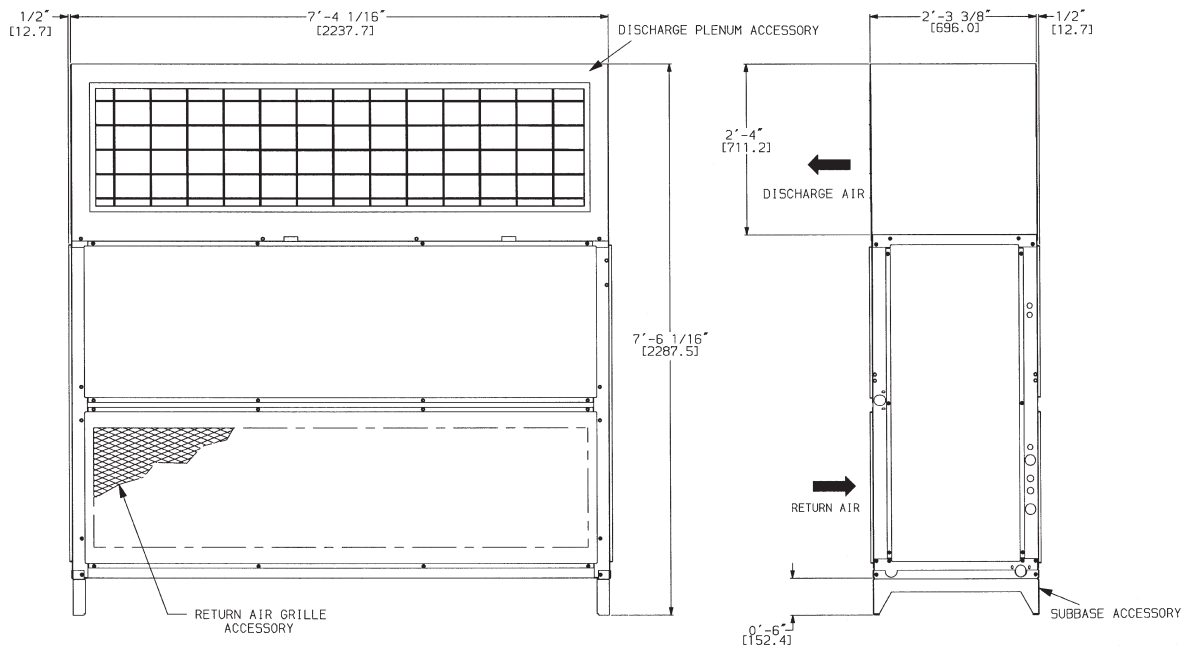

NOTE: Dimensions in [] are millimeters.

C150277

DIMENSIONS (cont.)

PLENUM, RETURN-AIR GRILLE, AND SUBBASE ACCESSORIES

UNIT SIZE 300

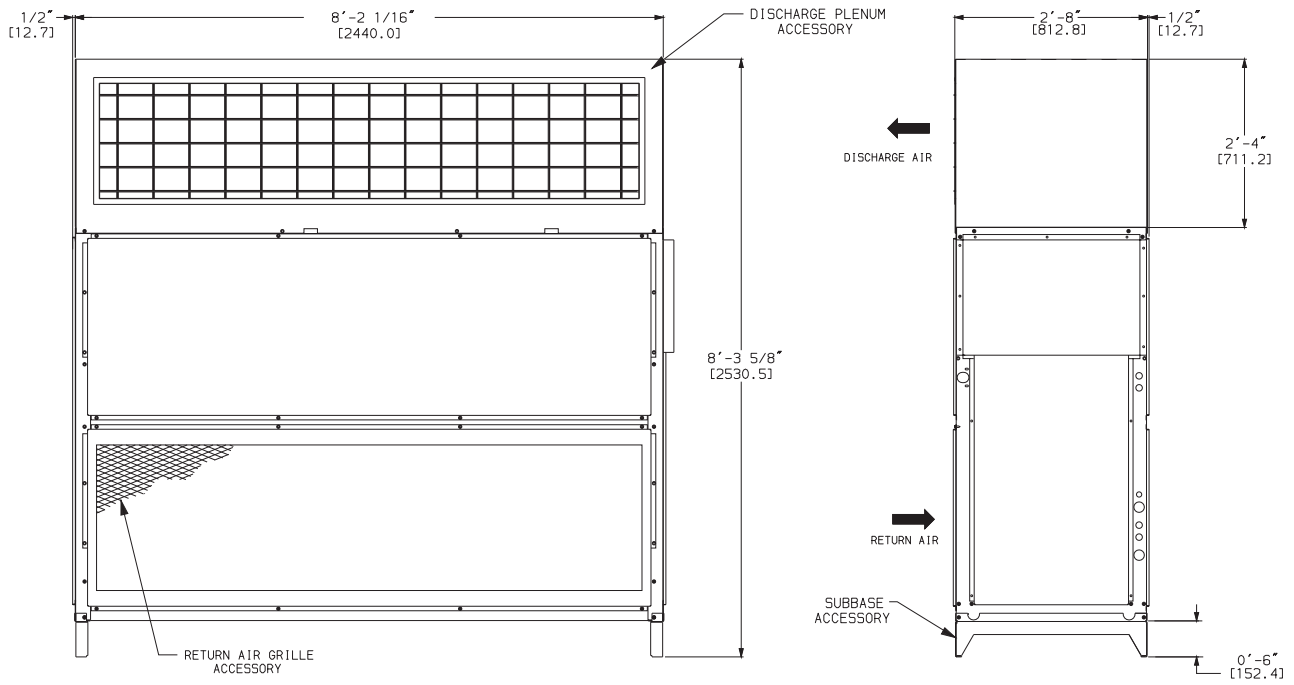

NOTE: Dimensions in [] are millimeters.

C150276

DIMENSIONS (cont.)

HOT WATER AND STEAM COIL ACCESSORIES

Unit Sizes 072-120

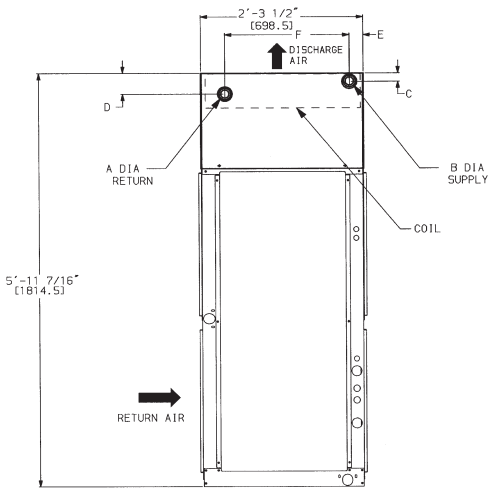
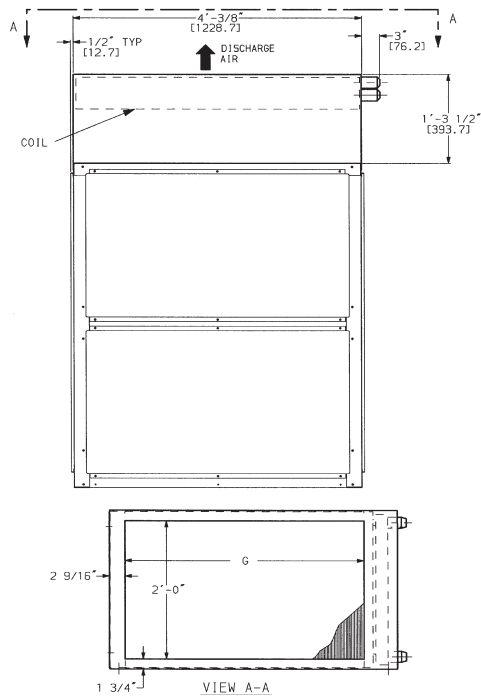

DIMENSION	HOT WATER COIL	STEAM COIL
A	1 1/2" MPT [38.1]	1 1/2" MPT [38.1]
B	1 1/2" MPT [38.1]	2 1/2" MPT [63.5]
C	2 3/8" [60.3]	3 1/8" [79.4]
D	4 7/8" [123.8]	3 1/8" [79.4]
E	2 1/8" [54.0]	4 9/16" [115.8]
F	1'-11 1/4" [590.6]	1'-9" [584.2]
G	3'-4" [1016.0]	3'-4" [1016.0]

NOTE: Dimensions in [] are millimeters.

C160024

Unit Sizes 180 & 240

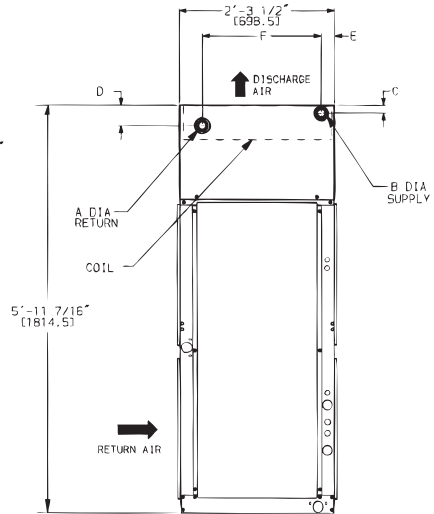
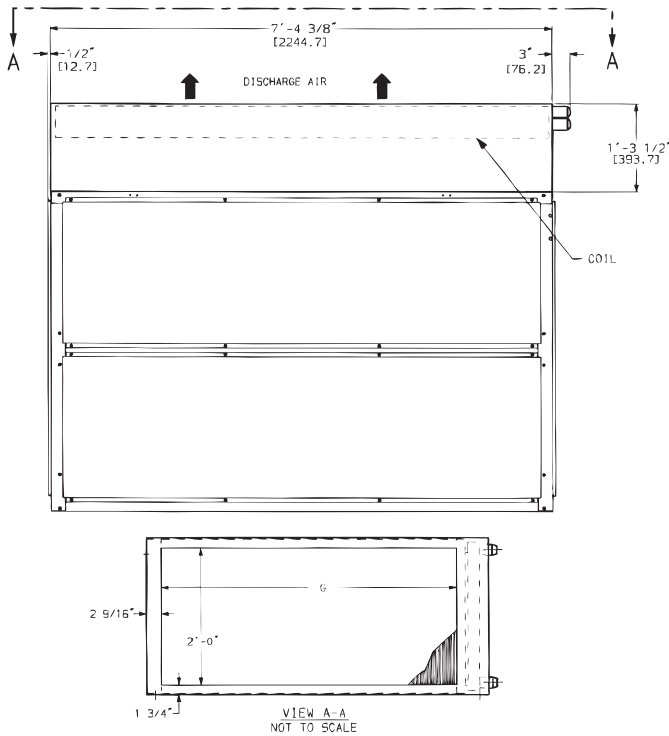

DIMENSION	HOT WATER COIL	STEAM COIL
A	2" MPT [50.8]	1 1/2" MPT [38.1]
B	2" MPT [50.8]	2 1/2" MPT [63.5]
C	2 3/8" [60.3]	3 1/8" [79.4]
D	4 7/8" [123.8]	3 1/8" [79.4]
E	2 1/8" [54.0]	4 9/16" [115.8]
F	1'-11 1/4" [590.6]	1'-9" [584.2]
G	6'-8" [2032.0]	6'-8" [2032.0]

DIMENSIONS (cont.)

HOT WATER AND STEAM COIL ACCESSORIES

UNIT SIZES 300

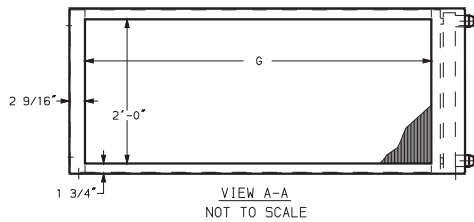
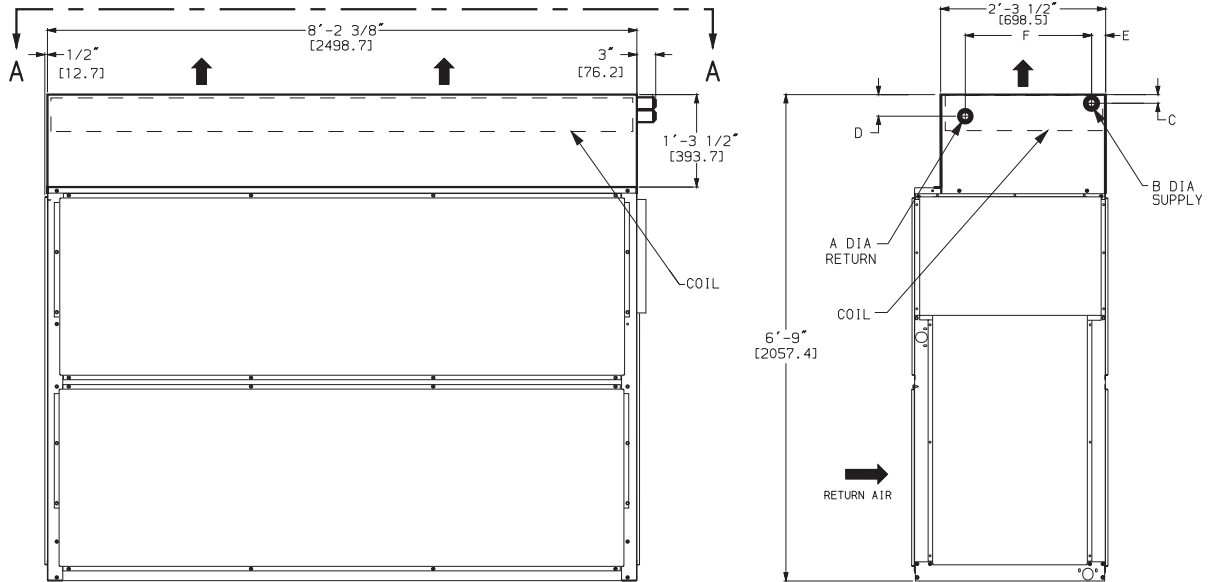

NOTE: Dimensions in [] are millimeters.

DIMENSION	HOT WATER COIL	STEAM COIL
A	2" MPT [50.8]	1 1/2" MPT [38.1]
B	2" MPT [50.8]	2 1/2" MPT [63.5]
C	2 3/8" [60.3]	3 1/8" [79.4]
D	4 7/8" [123.8]	3 1/8" [79.4]
E	2 1/8" [54.0]	4 9/16" [115.8]
F	1'-11 1/4" [590.6]	1'-9" [584.2]
G	7'-6" [2286.0]	7'-6" [2286.0]

C150273

DIMENSIONS (cont.)

ECONOMIZER ACCESSORY UNIT SIZES 072-120

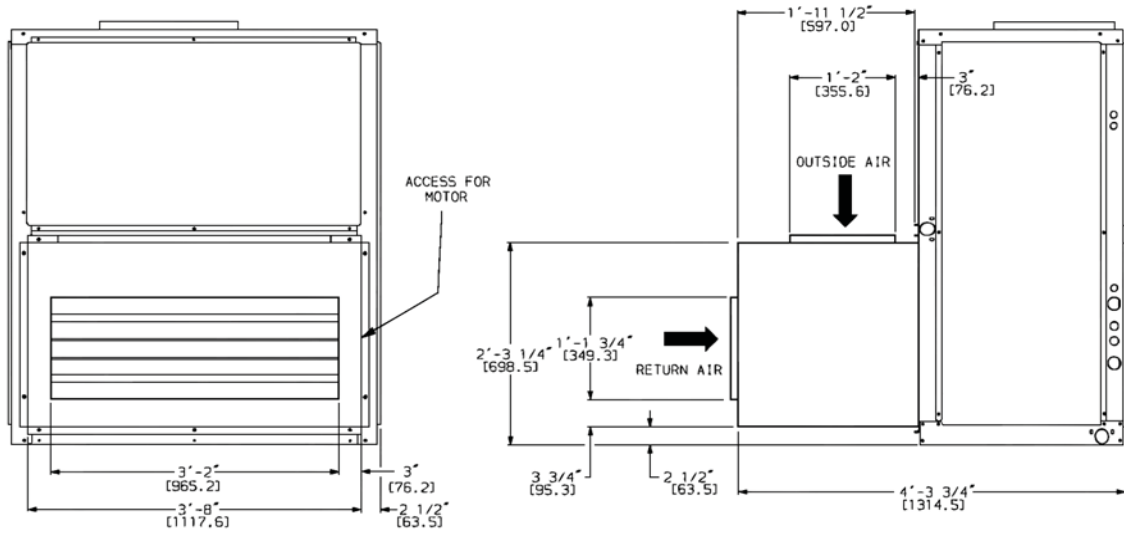

UNIT SIZES 150-240

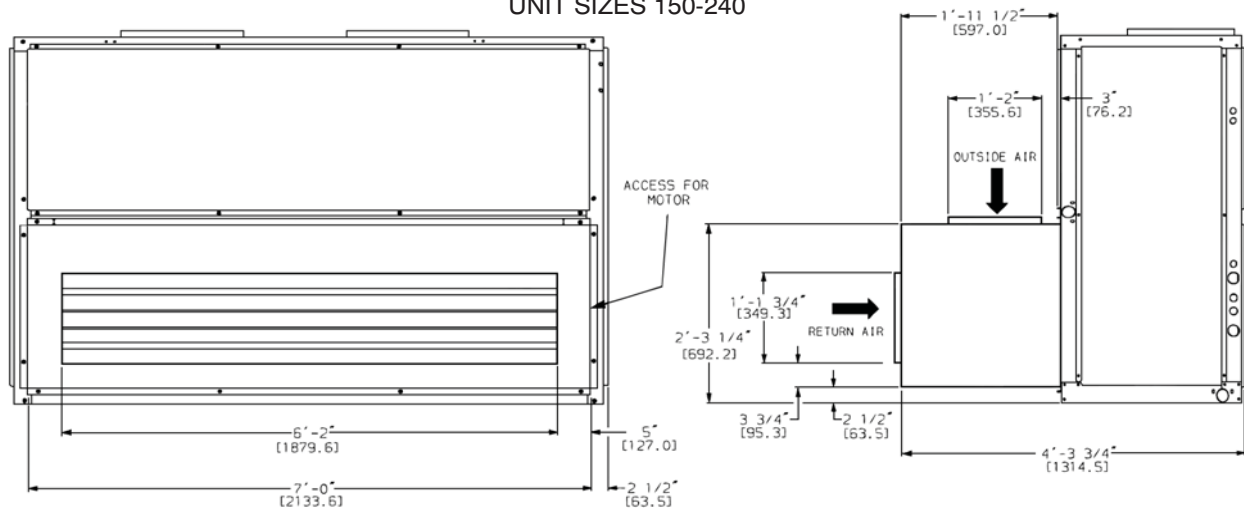

UNIT SIZE 300

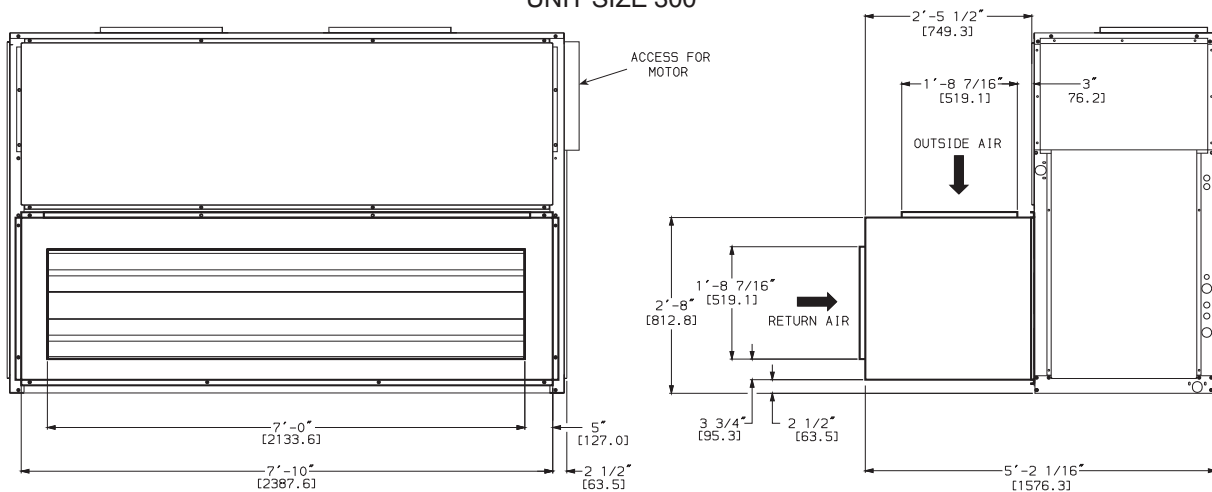

NOTE:

1. For horizontal unit applications, economizer can be attached to end of unit opposite duct connections.
2. Dimensions in [] are millimeters.

DIMENSIONS (cont.)

ELECTRIC HEAT ACCESSORY

UNIT SIZES 072 - 120

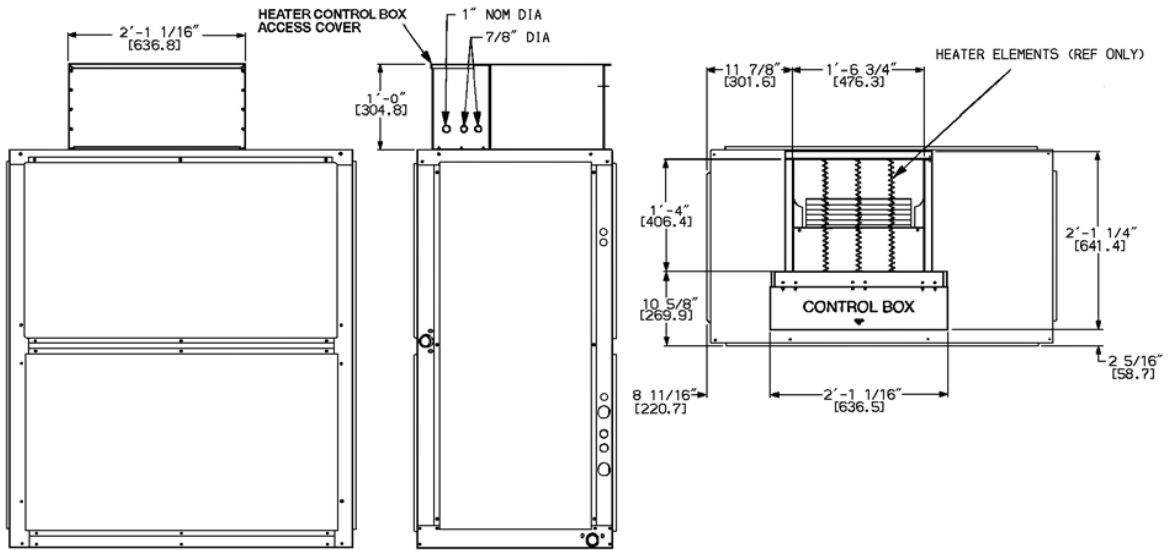

UNIT SIZE 14 - 28

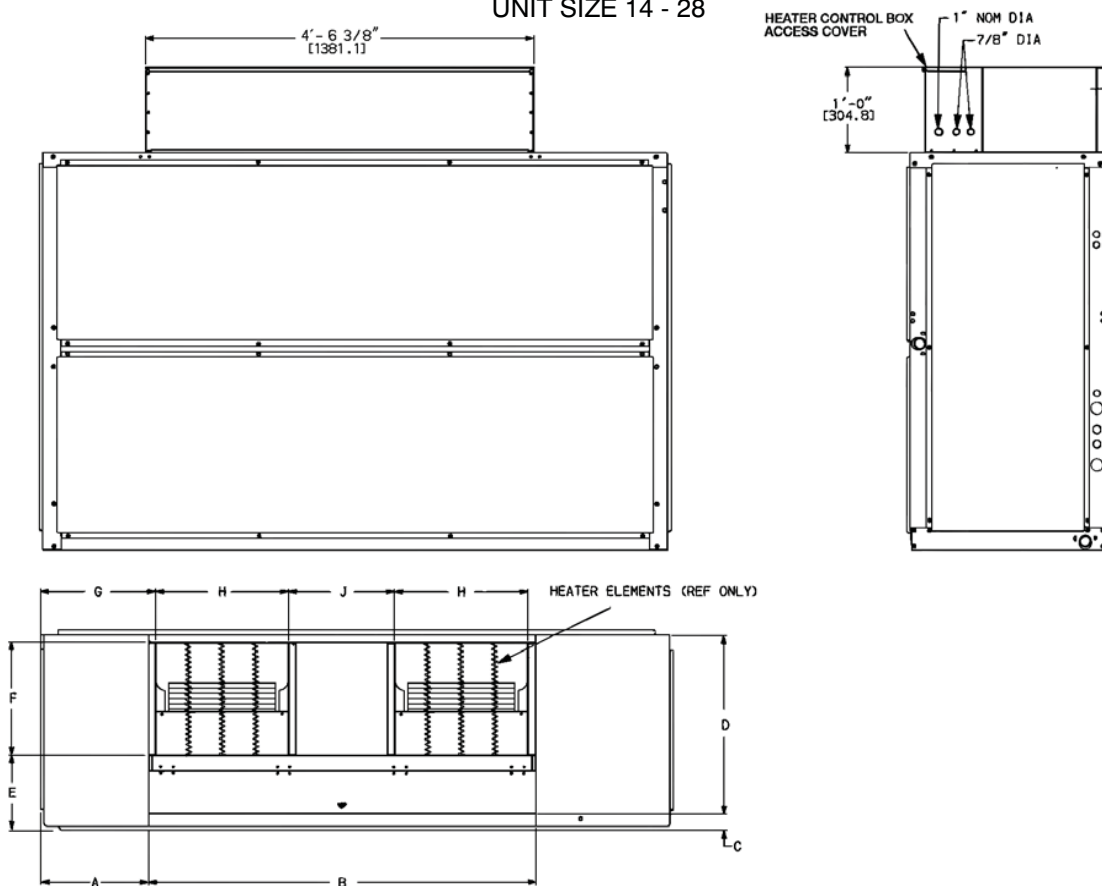

C160029

FAS UNIT SIZE	A	B	C	D	E	F	G	H	J
150 - 240	$1'-3 \frac{1}{4}"$ [387.4]	$4'-6 \frac{3}{8}"$ [1381.1]	$2 \frac{5}{16}"$ [58.7]	$2'-1 \frac{1}{4}"$ [641.4]	$10 \frac{5}{8}"$ [269.9]	$1'-4"$ [406.4]	$1'-4 \frac{5}{16}"$ [414.3]	$1'-6 \frac{3}{4}"$ [476.3]	$1'-7 \frac{7}{8}"$ [327.0]
300	$1'-3 \frac{3}{8}"$ [390.5]	$5'-4 \frac{7}{8}"$ [1636.8]	$2 \frac{1}{16}"$ [52.4]	$2'-6 \frac{3}{16}"$ [766.8]	$1'-1 \frac{1}{4}"$ [311.2]	$1'-7"$ [482.6]	$1'-4 \frac{5}{16}"$ [414.3]	$1'-10"$ [558.8]	$1-4 \frac{7}{16}"$ [417.1]

NOTE: Dimensions in [] are millimeters.

SELECTION PROCEDURE (WITH EXAMPLE)

Cooling (DX)

I. Determine the cooling load and temperature and quantity of air entering the evaporator.

Given:

Total Capacity 200,000 Btuh

Sensible Heat Capacity 130,000 Btuh

Air Temperature Entering Indoor

Coil 80°F (27°C)db, 67°F (19°C) wb

Air Quantity Entering Indoor Coil 6000 cfm

Ductwork Static Pressure Loss 0.8 in. wg

Power Supply 230-3-60

II. Determine unit selection and coil refrigerant temperature.

Enter the Cooling Capacities table at 6000 cfm. Select a FAS180 unit which has a total capacity of 207,000 and 174,000 Btuh at 40 and 45°F (4 and 7°C) coil refrigerant temperature, respectively. By interpolation, coil refrigerant temperature of 41.1°F (5.1°C) is needed to give a total capacity of 200,000 Btuh. Sensible capacity is approximately 149,000 Btuh. Cooling load is satisfied.

Heating (Hot Water Coil)

I. Determine heating load and temperature of air entering the indoor coil.

Given:

Load 425,000 Btuh

Entering-Air Temperature 70°F (21°C)

Coils 2-Row Hot Water

Coil Entering-Water Temperature 200°F (93°C)

Water Temperature Drop 20°F (-7°C)

II. Find the heating capacity.

Enter Hydronic Heating Capacities table for the FAS180 unit at 6000 cfm. A 2-row hot water coil delivers 471,000 Btuh (based on 60°F/16°C entering air temperature and 20°F/-7°C water temperature drop). Since existing entering air temperature is 70°F (21°C), enter the Heating Correction Factors table for hot water coils at 200°F (93°C) entering water temperature, 20°F (-7°C) water temperature drop and 70°F (21°C) entering air. Read a constant of 0.93.

$$471,000 \times 0.93 = 438,000$$

The 438,000 Btuh rating satisfies the heating load.

Fan

I. Determine fan speed and brake horsepower:

From the Accessory Pressure Drop table, read a loss of 0.23 in. wg for a hot water coil at 6000 cfm.

$$\text{External static pressure} = 0.80 + 0.23$$

$$= 1.03 \text{ in. wg}$$

Enter FAS Fan Performance table at 6000 cfm and 1.03 in. wg. Interpolate and determine fan speed of 864 rpm and 3.1 bhp.

II. Determine motor and drive.

Enter the fan motor data tables and find that the 230 v standard motor for a FAS180 unit is rated at 3.7 Hp. Since the bhp required is 3.1, a standard motor satisfies the requirement and should be used.

Next, find the type of drive that satisfies the 864 rpm requirement in the Drive Data tables. For a FAS180 unit, the Medium-Static Drive table shows an rpm range of 742 to 943. Since the rpm required is 864, the medium-static drive satisfies the requirement and should be used. Select the standard motor and medium-static drive combination (option code HC or FD).

To select an outdoor unit for this FAS180 indoor section, refer to the Combination Rating sheets for ICP condensing units in the condensing unit Specification Sheet.

PERFORMANCE DATA

FAS COOLING CAPACITIES

UNIT	EVAPORATOR AIR		COIL REFRIGERANT TEMP (°F)									
	Airflow (Cfm)	Ewb (°F)	30		35		40		45		50	
			TC	SHC	TC	SHC	TC	SHC	TC	SHC	TC	SHC
072	1,800	72	124	60	113	55	101	49	87	43	71	37
		67	104	64	93	59	81	53	67	47	52	40
		62	86	68	75	62	63	56	49	49	42	42
	2,400	72	143	69	131	64	117	58	101	52	83	44
		67	121	76	108	70	94	64	78	57	60	50
		62	101	83	88	76	73	69	60	60	51	51
	3,000	72	158	77	144	71	129	65	111	58	92	51
		67	134	86	121	80	105	73	87	66	67	58
		62	113	95	98	88	82	80	70	70	59	59
091	2,250	72	155	75	141	68	126	61	108	54	89	46
		67	130	80	116	73	101	66	83	59	64	51
		62	108	85	94	78	78	70	62	62	52	52
	3,000	72	179	86	164	80	146	72	126	64	103	56
		67	151	95	136	88	118	80	98	71	75	62
		62	126	103	110	95	92	86	76	76	64	64
	3,750	72	197	96	180	89	161	82	139	73	115	63
		67	168	108	151	100	131	92	109	82	84	72
		62	141	119	122	110	103	100	87	87	74	74
120	3,000	72	200	96	182	88	161	79	138	70	113	60
		67	168	104	150	96	130	86	107	76	83	66
		62	140	112	121	102	101	92	82	82	69	69
	4,000	72	228	111	208	102	185	93	159	83	130	71
		67	194	124	174	114	150	104	124	93	96	81
		62	162	135	141	124	119	113	99	99	84	84
	5,000	72	250	123	228	114	204	105	175	94	143	81
		67	214	140	192	130	166	119	138	107	106	94
		62	179	155	156	143	133	130	113	113	96	96
150	3,750	72	251	121	228	110	202	99	173	87	140	74
		67	210	129	187	118	161	106	133	94	102	81
		62	174	138	150	126	125	113	100	100	84	84
	5,000	72	289	139	263	128	233	116	200	103	162	88
		67	244	154	218	141	188	128	155	114	119	99
		62	203	167	176	153	146	138	121	121	102	102
	6,250	72	319	155	290	143	258	131	221	116	180	101
		67	271	174	242	161	209	147	172	132	133	115
		62	226	192	196	177	164	160	139	139	118	118
180	4,500	72	310	150	281	136	249	122	214	108	174	92
		67	260	160	231	145	199	131	165	116	127	100
		62	215	169	186	154	154	138	121	121	102	102
	6,000	72	361	175	329	161	292	145	250	128	205	110
		67	304	191	271	175	235	159	194	141	149	122
		62	254	206	220	189	183	170	149	149	125	125
	7,500	72	401	196	366	181	325	164	280	146	229	127
		67	340	218	304	201	263	183	218	164	167	143
		62	285	239	247	220	206	197	172	172	145	145

LEGEND

- db** — Dry-Bulb Temp (°F)
- Ewb** — Entering Wet-Bulb Temp (°F)
- lwb** — Leaving Wet-Bulb Temp (°F)
- SHC** — Sensible Heat Capacity (1000 Btuh)
- TC** — Total Capacity (1000 Btuh)

NOTES:

1. Ratings based on approximately 15°F superheat leaving coil.
2. Direct interpolation is permissible. Do not extrapolate.
3. Dashes indicate coil loading limits are exceeded.
4. Evaporator fan heat not deducted from ratings.

5. Formulas:

$$\text{Leaving db} = \text{entering db} - \frac{\text{sensible heat capacity (Btuh)}}{1.1 \times \text{cfm}}$$

$$\text{Leaving wb} = \text{wet-bulb temperature corresponding to enthalpy of air leaving coil (h}_{lwb}\text{)}$$

$$h_{lwb} = h_{ewb} - \frac{\text{total capacity (Btuh)}}{4.5 \times \text{cfm}}$$

where h_{lwb} = enthalpy of air entering coil

6. SHC is based on 80°F db temperature of air entering evaporator coil.

PERFORMANCE DATA (cont.)

FAS COOLING CAPACITIES (cont.)

UNIT	EVAPORATOR AIR		COIL REFRIGERANT TEMP (°F)									
	Airflow (Cfm)	Ewb (°F)	30		35		40		45		50	
			TC	SHC	TC	SHC	TC	SHC	TC	SHC	TC	SHC
240	6,000	72	408	197	372	180	331	162	272	141	232	123
		67	344	213	307	195	266	176	220	156	169	135
		62	286	227	248	208	207	188	164	164	139	139
	8,000	72	470	228	429	210	382	191	329	170	269	147
		67	399	253	357	233	309	212	256	189	197	166
		62	333	275	290	254	242	230	202	202	170	170
	10,000	72	516	253	471	235	421	215	363	192	297	168
		67	440	287	395	266	343	244	284	219	220	193
		62	369	317	322	294	271	266	232	232	196	196
300	7,500	72	470	226	428	208	379	187	328	167	270	144
		67	395	246	354	227	307	205	255	183	197	159
		62	329	265	287	244	240	221	193	193	163	163
	10,000	72	535	260	487	240	434	219	376	196	310	171
		67	454	291	407	269	354	246	295	221	228	194
		62	380	320	332	296	279	268	235	235	199	199
	12,500	72	583	287	531	267	475	245	412	221	341	194
		67	499	329	448	306	390	282	325	255	252	225
		62	420	367	367	341	310	310	269	269	228	228

LEGEND

- db** — Dry-Bulb Temp (°F)
- Ewb** — Entering Wet-Bulb Temp (°F)
- lwb** — Leaving Wet-Bulb Temp (°F)
- SHC** — Sensible Heat Capacity (1000 Btuh)
- TC** — Total Capacity (1000 Btuh)

NOTES:

1. Ratings based on approximately 15°F superheat leaving coil.
2. Direct interpolation is permissible. Do not extrapolate.
3. Dashes indicate coil loading limits are exceeded.
4. Evaporator fan heat not deducted from ratings.

5. Formulas:

$$\text{Leaving db} = \text{entering db} - \frac{\text{sensible heat capacity (Btuh)}}{1.1 \times \text{cfm}}$$

$$\text{Leaving wb} = \text{wet-bulb temperature corresponding to enthalpy of air leaving coil (h}_{lwb}\text{)}$$

$$h_{lwb} = h_{ewb} - \frac{\text{total capacity (Btuh)}}{4.5 \times \text{cfm}}$$

where h_{lwb} = enthalpy of air entering coil

6. SHC is based on 80°F db temperature of air entering evaporator coil.

PERFORMANCE DATA (cont.)

HYDRONIC HEATING CAPACITIES

FAS UNIT	AIRFLOW (Cfm)	1-ROW STEAM*		2-ROW HOT WATER COIL†			
		Cap.	Ldb	Cap.	Ldb	Water Flow (Gpm)	PD
072	1,800	146	134	156.0	140	15.6	3.4
	2,400	173	126	183.0	131	18.3	4.3
	3,000	209	123	206.0	124	20.6	5.2
091	2,250	168	129	174.0	133	17.4	4.0
	3,000	209	123	206.0	124	20.6	5.2
	3,750	240	117	238.0	118	23.8	6.5
120	3,000	209	123	299.0	152	29.9	5.0
	4,000	243	115	275.0	124	27.5	6.6
	5,000	279	111	316.0	119	31.6	8.2
150	3,750	370	150	362.0	149	36.2	4.2
	5,000	425	137	409.0	136	40.9	5.1
	6,250	465	128	456.0	128	45.6	6.0
180	4,500	402	141	412.0	145	41.2	4.5
	6,000	458	129	471.0	133	47.1	5.5
	7,500	479	118	529.0	125	52.9	6.6
240	6,000	458	129	506.0	138	50.6	5.1
	8,000	487	115	584.0	128	58.4	6.3
	10,000	499	105	652.0	120	65.2	7.5
300	7,500	511	122	649.0	140	64.9	5.7
	10,000	575	112	752.0	130	75.2	7.1
	12,500	626	106	842.0	122	84.2	8.5

LEGEND:

Cap. – Capacity (Btuh in thousands)

Ldb – Leaving Air Dry Bulb Temp (°F)

PD – Pressure Drop (ft water)

* Based on 5 psig steam, 60°F entering-air temperature. All steam coils are non-freeze type.

† Based on 200°F entering water, 20°F water temperature drop, 60°F entering-air temperature.

NOTES:

1. Maximum operating limits for heating coils: 20 psig at 260°F.

2. Leaving db = ent db (°F) + $\frac{\text{Capacity (Btuh)}}{1.1 \times \text{cfm}}$

3. See Heating Correction Factors table.

HEATING CORRECTION FACTORS

HOT WATER COIL						
Water Temp Drop (°F)	Ent Water Temp (°F)	Entering-Air Temp (°F)				
		40	50	60	70	80
10	140	0.72	0.64	0.57	0.49	0.41
	160	0.89	0.81	0.74	0.66	0.58
	180	1.06	0.98	0.90	0.83	0.75
	200	1.22	1.15	1.07	1.00	0.92
20	220	1.39	1.32	1.24	1.17	1.09
	140	0.64	0.57	0.49	0.41	0.33
	160	0.81	0.74	0.66	0.58	0.51
	180	0.98	0.91	0.83	0.75	0.68
30	200	1.15	1.08	1.00	0.93	0.85
	220	1.32	1.25	1.17	1.10	1.02
	140	0.56	0.49	0.41	0.33	0.24
	160	0.74	0.66	0.58	0.51	0.43
30	180	0.91	0.83	0.76	0.68	0.60
	200	1.08	1.00	0.93	0.85	0.78
	220	1.25	1.18	1.10	1.03	0.95

STEAM COIL					
Steam Pressure (psig)	Entering-Air Temp (°F)				
	40	50	60	70	80
0	1.06	0.98	0.91	0.85	0.78
2	1.09	1.02	0.95	0.89	0.82
5	1.13	1.06	1.00	0.93	0.87

NOTE: Multiply capacity given in the Hydronic Heating Capacities table by the correction factor for conditions at which unit is actually operating. Correct leaving-air temperature using formula in Note 2 of Hydronic Heating Capacities table.

PERFORMANCE DATA (cont.)

FAN PERFORMANCE DATA — FAS 0.0-1.2 in. wg ESP — 60 Hz

FAS UNIT	AIRFLOW (Cfm)	EXTERNAL STATIC PRESSURE (in. wg)													
		0.0		0.2		0.4		0.6		0.8		1.0		1.2	
		Rpm	Bhp	Rpm	Bhp	Rpm	Bhp	Rpm	Bhp	Rpm	Bhp	Rpm	Bhp	Rpm	Bhp
072	1,800	419	0.21	471	0.26	564	0.37	649	0.49	<u>727</u>	<u>0.63</u>	<u>797</u>	<u>0.77</u>	<u>862</u>	<u>0.92</u>
	2,100	471	0.31	519	0.37	602	0.49	679	<u>0.62</u>	<u>751</u>	<u>0.77</u>	<u>819</u>	<u>0.92</u>	<u>882</u>	<u>1.09</u>
	2,400	524	0.44	568	0.51	645	0.64	715	<u>0.79</u>	<u>781</u>	<u>0.94</u>	<u>844</u>	<u>1.11</u>	<u>905</u>	<u>1.28</u>
	2,700	578	0.61	619	0.69	<u>690</u>	<u>0.84</u>	<u>755</u>	<u>0.99</u>	<u>816</u>	<u>1.15</u>	<u>875</u>	<u>1.33</u>	<u>932</u>	<u>1.51</u>
	3,000	633	0.81	<u>671</u>	<u>0.90</u>	<u>738</u>	<u>1.07</u>	<u>799</u>	<u>1.24</u>	<u>856</u>	<u>1.41</u>	<u>910</u>	<u>1.60</u>	<u>963</u>	<u>1.79</u>
091	2,250	290	0.10	510	0.39	594	0.51	669	0.65	739	0.79	<u>806</u>	<u>0.95</u>	<u>870</u>	<u>1.12</u>
	2,600	349	0.19	561	0.55	640	0.70	709	0.84	<u>773</u>	<u>1.00</u>	<u>834</u>	<u>1.16</u>	<u>893</u>	<u>1.34</u>
	3,000	579	0.70	621	0.79	695	0.96	<u>759</u>	<u>1.12</u>	<u>818</u>	<u>1.30</u>	<u>874</u>	<u>1.47</u>	<u>928</u>	<u>1.66</u>
	3,400	646	0.99	683	1.09	<u>752</u>	<u>1.29</u>	<u>813</u>	<u>1.48</u>	<u>869</u>	<u>1.67</u>	<u>920</u>	<u>1.86</u>	<u>970</u>	<u>2.06</u>
	3,750	705	1.31	739	1.42	<u>804</u>	<u>1.63</u>	<u>862</u>	<u>1.85</u>	<u>915</u>	<u>2.05</u>	<u>964</u>	<u>2.26</u>	<u>1011</u>	<u>2.48</u>
120	3,000	421	0.35	592	0.73	670	0.90	737	1.06	<u>797</u>	<u>1.23</u>	<u>854</u>	<u>1.41</u>	<u>908</u>	<u>1.59</u>
	3,500	626	0.98	664	1.08	735	1.28	798	1.48	<u>855</u>	<u>1.67</u>	<u>908</u>	<u>1.87</u>	<u>958</u>	<u>2.07</u>
	4,000	706	1.42	738	1.54	803	1.77	862	2.00	<u>917</u>	<u>2.23</u>	<u>967</u>	<u>2.45</u>	<u>1014</u>	<u>2.67</u>
	4,500	786	1.99	815	2.12	<u>873</u>	<u>2.39</u>	<u>929</u>	<u>2.65</u>	<u>980</u>	<u>2.90</u>	<u>1028</u>	<u>3.16</u>	<u>1073</u>	<u>3.41</u>
	5,000	867	<u>2.70</u>	<u>893</u>	<u>2.84</u>	<u>946</u>	<u>3.14</u>	<u>997</u>	<u>3.43</u>	<u>1046</u>	<u>3.72</u>	<u>1092</u>	<u>4.00</u>	<u>1135</u>	<u>4.28</u>
150	3,750	410	0.43	467	0.55	567	0.83	649	1.12	721	1.41	<u>788</u>	<u>1.72</u>	<u>851</u>	<u>2.05</u>
	4,300	455	0.62	504	0.74	599	1.05	679	1.38	<u>748</u>	<u>1.70</u>	<u>811</u>	<u>2.04</u>	<u>871</u>	<u>2.39</u>
	5,000	514	0.92	556	1.06	641	1.39	718	1.76	<u>786</u>	<u>2.14</u>	<u>847</u>	<u>2.52</u>	<u>903</u>	<u>2.91</u>
	5,700	575	1.32	612	1.47	686	1.82	<u>759</u>	<u>2.23</u>	<u>825</u>	<u>2.66</u>	<u>884</u>	<u>3.09</u>	<u>939</u>	<u>3.52</u>
	6,250	624	1.71	657	1.87	725	2.24	<u>793</u>	<u>2.66</u>	<u>856</u>	<u>3.12</u>	<u>915</u>	<u>3.59</u>	<u>969</u>	<u>4.06</u>
180	4,500	437	0.61	483	0.72	576	1.01	660	1.35	<u>732</u>	<u>1.69</u>	<u>797</u>	<u>2.03</u>	<u>856</u>	<u>2.38</u>
	5,300	499	0.95	538	1.07	617	1.37	696	1.74	<u>767</u>	<u>2.13</u>	<u>830</u>	<u>2.53</u>	<u>888</u>	<u>2.94</u>
	6,000	555	1.34	590	1.48	659	1.79	<u>730</u>	<u>2.17</u>	<u>798</u>	<u>2.59</u>	<u>860</u>	<u>3.04</u>	<u>918</u>	<u>3.49</u>
	6,800	620	1.91	651	2.06	712	2.39	<u>774</u>	<u>2.78</u>	<u>836</u>	<u>3.22</u>	<u>896</u>	<u>3.71</u>	<u>952</u>	<u>4.21</u>
	7,500	677	2.52	706	2.69	<u>761</u>	<u>3.04</u>	<u>817</u>	<u>3.44</u>	<u>873</u>	<u>3.89</u>	<u>929</u>	<u>4.39</u>	<u>984</u>	<u>4.93</u>
240	6,000	542	1.29	577	1.42	646	1.72	716	2.09	785	2.51	849	2.95	<u>907</u>	<u>3.40</u>
	7,000	620	1.99	652	2.15	711	2.48	771	2.85	831	3.28	<u>890</u>	<u>3.76</u>	<u>947</u>	<u>4.27</u>
	8,000	700	2.92	728	3.10	781	3.46	833	3.85	<u>885</u>	<u>4.29</u>	<u>938</u>	<u>4.78</u>	<u>990</u>	<u>5.32</u>
	9,000	781	4.10	806	4.30	854	4.71	900	<u>5.13</u>	<u>946</u>	<u>5.58</u>	<u>993</u>	<u>6.08</u>	<u>1039</u>	<u>6.62</u>
	10,000	862	5.56	<u>885</u>	<u>5.79</u>	<u>929</u>	<u>6.24</u>	<u>971</u>	<u>6.70</u>	<u>1012</u>	<u>7.18</u>	<u>1054</u>	<u>7.69</u>	<u>1096</u>	<u>8.24</u>
300	7,500	476	1.39	510	1.58	579	1.99	644	2.40	701	2.81	752	3.29	804	3.96
	8,750	545	2.14	574	2.35	633	2.81	691	3.29	747	3.77	797	4.25	<u>842</u>	<u>4.76</u>
	10,000	615	3.12	641	3.36	692	3.87	743	4.41	794	4.96	<u>843</u>	<u>5.51</u>	<u>888</u>	<u>6.05</u>
	11,250	685	4.37	709	4.64	754	5.20	800	5.79	<u>845</u>	<u>6.40</u>	<u>891</u>	<u>7.02</u>	<u>935</u>	<u>7.64</u>
	12,500	756	5.92	778	6.22	819	6.83	<u>860</u>	<u>7.47</u>	<u>901</u>	<u>8.14</u>	<u>942</u>	<u>8.83</u>	<u>983</u>	<u>9.52</u>

LEGEND

Bhp — Brake Horsepower Input to Fan

ESP — External Static Pressure

Bold indicates field-supplied drive is required.

Plain type indicates standard motor and standard drive.

Underline indicates a different motor and drive combination other than the standard motor and standard drive combination is required. Refer to fan motor and drive tables to complete selection.

NOTES:

Maximum allowable fan speed is 1100 rpm for unit size 28; 1200 rpm for all other sizes. Fan performance is based on deductions for wet coil, clean 2-in. filters, and unit casing. See table on page 27 for factory-supplied filter pressure drop. For 60 Hz units, the medium-static drive and standard motor combination is not available for 28 size.

PERFORMANCE DATA (cont.)

FAN PERFORMANCE DATA — FAS 1.4-2.4 in. wg ESP — 60 Hz

FAS UNIT	AIRFLOW (Cfm)	EXTERNAL STATIC PRESSURE (in. wg)											
		1.4		1.6		1.8		2.0		2.2		2.4	
		Rpm	Bhp	Rpm	Bhp	Rpm	Bhp	Rpm	Bhp	Rpm	Bhp	Rpm	Bhp
072	1,800	<u>921</u>	<u>1.07</u>	<u>975</u>	<u>1.23</u>	<u>1026</u>	<u>1.39</u>	<u>1074</u>	<u>1.55</u>	<u>1120</u>	<u>1.72</u>	<u>1164</u>	<u>1.90</u>
	2,100	<u>942</u>	<u>1.26</u>	<u>997</u>	<u>1.43</u>	<u>1048</u>	<u>1.61</u>	<u>1097</u>	<u>1.79</u>	<u>1143</u>	<u>1.97</u>	<u>1186</u>	<u>2.16</u>
	2,400	<u>963</u>	<u>1.47</u>	<u>1017</u>	<u>1.66</u>	<u>1069</u>	<u>1.85</u>	<u>1118</u>	<u>2.05</u>	<u>1164</u>	<u>2.25</u>	—	—
	2,700	<u>987</u>	<u>1.71</u>	<u>1039</u>	<u>1.91</u>	<u>1090</u>	<u>2.12</u>	<u>1138</u>	<u>2.33</u>	<u>1185</u>	<u>2.55</u>	—	—
	3,000	<u>1015</u>	<u>1.99</u>	<u>1065</u>	<u>2.20</u>	<u>1113</u>	<u>2.42</u>	<u>1161</u>	<u>2.65</u>	—	—	—	—
091	2,250	<u>930</u>	<u>1.29</u>	<u>986</u>	<u>1.47</u>	<u>1039</u>	<u>1.65</u>	<u>1089</u>	<u>1.84</u>	<u>1136</u>	<u>2.03</u>	<u>1181</u>	<u>2.22</u>
	2,600	<u>950</u>	<u>1.53</u>	<u>1005</u>	<u>1.72</u>	<u>1057</u>	<u>1.92</u>	<u>1107</u>	<u>2.13</u>	<u>1154</u>	<u>2.33</u>	—	—
	3,000	<u>980</u>	<u>1.86</u>	<u>1031</u>	<u>2.06</u>	<u>1081</u>	<u>2.27</u>	<u>1129</u>	<u>2.49</u>	<u>1175</u>	<u>2.72</u>	—	—
	3,400	<u>1018</u>	<u>2.26</u>	<u>1065</u>	<u>2.48</u>	<u>1111</u>	<u>2.70</u>	<u>1156</u>	<u>2.93</u>	—	—	—	—
	3,750	<u>1057</u>	<u>2.69</u>	<u>1101</u>	<u>2.92</u>	<u>1144</u>	<u>3.15</u>	<u>1186</u>	<u>3.39</u>	—	—	—	—
120	3,000	<u>961</u>	<u>1.78</u>	<u>1012</u>	<u>1.98</u>	<u>1062</u>	<u>2.19</u>	<u>1111</u>	<u>2.41</u>	<u>1158</u>	<u>2.64</u>	—	—
	3,500	<u>1005</u>	<u>2.27</u>	<u>1052</u>	<u>2.49</u>	<u>1098</u>	<u>2.71</u>	<u>1142</u>	<u>2.94</u>	<u>1186</u>	<u>3.18</u>	—	—
	4,000	<u>1058</u>	<u>2.90</u>	<u>1101</u>	<u>3.13</u>	<u>1143</u>	<u>3.36</u>	<u>1184</u>	<u>3.60</u>	—	—	—	—
	4,500	<u>1116</u>	<u>3.66</u>	<u>1157</u>	<u>3.91</u>	<u>1196</u>	<u>4.16</u>	—	—	—	—	—	—
	5,000	<u>1176</u>	<u>4.56</u>	—	—	—	—	—	—	—	—	—	—
150	3,750	<u>912</u>	<u>2.39</u>	<u>971</u>	<u>2.76</u>	<u>1028</u>	<u>3.14</u>	<u>1083</u>	<u>3.54</u>	<u>1135</u>	<u>3.95</u>	<u>1185</u>	<u>4.36</u>
	4,300	<u>928</u>	<u>2.75</u>	<u>982</u>	<u>3.13</u>	<u>1036</u>	<u>3.53</u>	<u>1087</u>	<u>3.94</u>	<u>1138</u>	<u>4.37</u>	<u>1187</u>	<u>4.81</u>
	5,000	<u>956</u>	<u>3.30</u>	<u>1007</u>	<u>3.71</u>	<u>1056</u>	<u>4.13</u>	<u>1104</u>	<u>4.56</u>	<u>1151</u>	<u>5.00</u>	<u>1196</u>	<u>5.46</u>
	5,700	<u>990</u>	<u>3.96</u>	<u>1039</u>	<u>4.40</u>	<u>1086</u>	<u>4.85</u>	<u>1130</u>	<u>5.31</u>	<u>1174</u>	<u>5.78</u>	—	—
	6,250	<u>1019</u>	<u>4.54</u>	<u>1067</u>	<u>5.02</u>	<u>1112</u>	<u>5.50</u>	<u>1156</u>	<u>5.99</u>	<u>1198</u>	<u>6.49</u>	—	—
180	4,500	<u>912</u>	<u>2.75</u>	<u>967</u>	<u>3.12</u>	<u>1019</u>	<u>3.52</u>	<u>1070</u>	<u>3.92</u>	<u>1120</u>	<u>4.35</u>	<u>1168</u>	<u>4.79</u>
	5,300	<u>942</u>	<u>3.34</u>	<u>992</u>	<u>3.76</u>	<u>1041</u>	<u>4.18</u>	<u>1088</u>	<u>4.61</u>	<u>1134</u>	<u>5.06</u>	<u>1179</u>	<u>5.52</u>
	6,000	<u>971</u>	<u>3.95</u>	<u>1020</u>	<u>4.40</u>	<u>1067</u>	<u>4.86</u>	<u>1112</u>	<u>5.33</u>	<u>1156</u>	<u>5.81</u>	<u>1198</u>	<u>6.29</u>
	6,800	<u>1005</u>	<u>4.72</u>	<u>1054</u>	<u>5.23</u>	<u>1101</u>	<u>5.75</u>	<u>1145</u>	<u>6.27</u>	<u>1187</u>	<u>6.79</u>	—	—
	7,500	<u>1036</u>	<u>5.48</u>	<u>1084</u>	<u>6.04</u>	<u>1131</u>	<u>6.61</u>	<u>1174</u>	<u>7.17</u>	—	—	—	—
240	6,000	<u>961</u>	<u>3.86</u>	<u>1011</u>	<u>4.31</u>	<u>1058</u>	<u>4.77</u>	<u>1104</u>	<u>5.24</u>	<u>1147</u>	<u>5.71</u>	—	—
	7,000	<u>1000</u>	<u>4.79</u>	<u>1050</u>	<u>5.32</u>	<u>1097</u>	<u>5.85</u>	<u>1142</u>	<u>6.38</u>	<u>1184</u>	<u>6.91</u>	—	—
	8,000	<u>1041</u>	<u>5.88</u>	<u>1090</u>	<u>6.47</u>	<u>1137</u>	<u>7.07</u>	<u>1181</u>	<u>7.67</u>	—	—	—	—
	9,000	<u>1086</u>	<u>7.21</u>	<u>1133</u>	<u>7.82</u>	<u>1178</u>	<u>8.47</u>	—	—	—	—	—	—
	10,000	<u>1138</u>	<u>8.83</u>	<u>1180</u>	<u>9.46</u>	—	—	—	—	—	—	—	—
300	7,500	<u>874</u>	<u>5.33</u>	<u>897</u>	<u>5.91</u>	<u>940</u>	<u>6.80</u>	<u>990</u>	<u>7.50</u>	—	—	—	—
	8,750	<u>886</u>	<u>5.36</u>	<u>930</u>	<u>6.13</u>	<u>982</u>	<u>7.32</u>	<u>1020</u>	<u>8.10</u>	—	—	—	—
	10,000	<u>930</u>	<u>6.60</u>	<u>969</u>	<u>7.20</u>	<u>1007</u>	<u>7.89</u>	<u>1045</u>	<u>8.71</u>	—	—	—	—
	11,250	<u>976</u>	<u>8.25</u>	<u>1014</u>	<u>8.86</u>	<u>1051</u>	<u>9.49</u>	<u>1086</u>	<u>10.17</u>	—	—	—	—
	12,500	<u>1023</u>	<u>10.20</u>	<u>1061</u>	<u>10.88</u>	<u>1097</u>	<u>11.56</u>	—	—	—	—	—	—

LEGEND

Bhp — Brake Horsepower Input to Fan

ESP — External Static Pressure

Bold indicates field-supplied drive is required.

Plain type indicates standard motor and standard drive.

Underline indicates a different motor and drive combination other than the standard motor and standard drive combination is required. Refer to fan motor and drive tables to complete selection.

NOTES:

Maximum allowable fan speed is 1100 rpm for unit size 28; 1200 rpm for all other sizes. Fan performance is based on deductions for wet coil, clean 2-in. filters, and unit casing. See table on page 27 for factory-supplied filter pressure drop. For 60 Hz units, the medium-static drive and standard motor combination is not available for 28 size.

PERFORMANCE DATA (cont.)

DUCT SOUND POWER LEVELS (Lw)

MODEL	SIZE	CFM	dB(A)	OCTAVE BAND CENTER FREQUENCY (Hz)						
				63	125	250	500	1000	2000	4000
FAS	072	2,400	86.3	93.2	89.2	85.2	84.2	80.2	78.2	74.2
	091	3,000	88.3	95.3	91.3	87.3	86.3	82.3	80.3	76.3
	120	4,000	91.6	98.6	94.6	90.6	89.6	85.6	83.6	79.6
	150	5,000	91.1	97.3	93.3	89.3	90.3	84.3	82.3	78.3
	180	6,000	92.7	98.9	94.9	90.9	91.9	85.9	83.9	79.9
	240	8,000	96.4	102.6	98.6	94.6	95.6	89.6	87.6	83.6
	300	10,000	96.2	102.5	98.5	94.5	95.5	89.5	87.5	83.5

LEGEND:

ASHRAE – American Society of Heating, Refrigerating and Air Conditioning, Inc.
 HVAC – Heating, Ventilation and Air Conditioning

NOTES:

1. The above estimated sound power levels are based upon the ASHRAE calculation approach from the ASHRAE 1987 HVAC Systems and Applications handbook, Chapter 52.
2. Since this data is calculated, these sound power levels may be different than the actual sound power levels.
3. The acoustic center of the unit is located at the geometric center of the unit.

FACTORY-SUPPLIED FILTER PRESSURE DROP

UNIT SIZE	AIRFLOW (Cfm)	PRESSURE DROP (in. wg)
072	1,800	0.05
	2,400	0.08
	3,000	0.11
091	2,250	0.07
	3,000	0.11
	3,750	0.15
120	3,000	0.11
	4,000	0.17
	5,000	0.23
150	3,750	0.06
	5,000	0.10
	6,250	0.13
180	4,500	0.08
	6,000	0.12
	7,500	0.17
240	6,000	0.12
	8,000	0.19
	10,000	0.26
300	7,500	0.15
	10,000	0.22
	12,500	0.30

ACCESSORY PLENUM AIR THROW DATA

UNIT	AIRFLOW (Cfm)	VANE DEFLECTION		
		Straight	21 1/2°	45°
072	2,400	39	33	24
091	3,000	45	38	28
120	4,000	55	46	33
150	5,000	45	38	28
180	6,000	50	43	31
240	8,000	60	51	37
300	10,000	76	65	47

NOTE: Throw distances shown are for 75 fpm terminal velocity. Use the following multipliers to determine throw values for other terminal velocities.

TERMINAL VELOCITY (Fpm)	THROW FACTOR
50	X 1.50
100	X 0.75
150	X 0.50

PERFORMANCE DATA (cont.)

ACCESSORY PRESSURE DROP — in. wg

UNIT SIZE	AIRFLOW (Cfm)	DISCHARGE PLENUM	RETURN AIR GRILLE	Hot Water	Steam	Electric	ECONOMIZER
072	1,800	0.06	0.01	0.10	0.10	0.04	0.05
	2,400	0.10	0.01	0.16	0.16	0.06	0.07
	3,000	0.14	0.02	0.23	0.23	0.10	0.09
091	2,250	0.09	0.01	0.15	0.15	0.06	0.06
	3,000	0.14	0.02	0.23	0.23	0.10	0.09
	3,750	0.21	0.03	0.35	0.35	0.15	0.15
120	3,000	0.14	0.02	0.23	0.23	0.10	0.09
	4,000	0.22	0.04	0.37	0.37	0.17	0.17
	5,000	0.32	0.06	0.53	0.53	0.26	0.28
150	3,750	0.07	0.01	0.11	0.11	0.04	0.05
	5,000	0.12	0.02	0.17	0.17	0.07	0.07
	6,250	0.17	0.02	0.25	0.25	0.11	0.11
180	4,500	0.10	0.01	0.15	0.15	0.06	0.06
	6,000	0.16	0.02	0.23	0.23	0.10	0.09
	7,500	0.23	0.03	0.33	0.33	0.15	0.15
240	6,000	0.16	0.02	0.23	0.23	0.10	0.09
	8,000	0.26	0.04	0.37	0.37	0.17	0.17
	10,000	0.37	0.06	0.53	0.53	0.26	0.28
300	7,500	0.15	0.02	0.28	0.28	0.09	0.06
	10,000	0.24	0.03	0.44	0.44	0.16	0.09
	12,500	0.34	0.05	0.63	0.63	0.24	0.14

ELECTRICAL DATA

Table 1 – Electrical Data, Standard Motors with Factory-Installed Single Speed Fan Option

UNIT	V-PH-Hz†	VOLTAGE LIMITS	FAN MOTOR		POWER SUPPLY	
			Hp (kW)	FLA	Minimum Circuit Amps	MAX FUSE or HACR BRKR
072	208/230-1-60	187-253	1.3 (0.97)	6.60	9.00	15
	208/230-3-60	187-253	2.4 (1.79)	5.2	7.0	15
	460-3-60	414-506	2.4 (1.79)	2.6	4.0	15
	575-3-60	518-632	1.0 (0.75)	1.40	2.0	15
091	208/230-1-60	187-253	2.4 (1.79)	11.00	13.80	20
	208/230-3-60	187-253	2.4 (1.79)	5.2	7.0	15
	460-3-60	414-506	2.4 (1.79)	2.6	4.0	15
	575-3-60	518-632	2.0 (1.49)	2.40	3.0	15
120	208/230-3-60	187-253	2.4 (1.79)	5.2	7.0	15
	460-3-60	414-506	2.4 (1.79)	2.6	4.0	15
	575-3-60	518-632	2.0 (1.49)	2.40	3.0	15
150	208/230-3-60	187-253	2.9 (2.16)	7.5	10.0	15
	460-3-60	414-506	2.9 (2.16)	3.4	5.0	15
	575-3-60	518-632	3.0 (2.24)	3.80	5.0	15
180	208/230-3-60	187-253	3.7 (2.76)	10.2	13.0	20
	460-3-60	414-506	3.7 (2.76)	4.8	6.0	15
	575-3-60	518-632	3.0 (2.24)	3.80	5.0	15
240	208/230-3-60	187-253	5.0 (3.73)	18.0	23.0	40
	460-3-60	414-506	5.0 (3.73)	9.1	12.0	20
	575-3-60	518-632	5.0 (3.73)	8.0	10.0	15
300	208/230-3-60	187-253	7.5 (5.59)	23.5	30.0	50
	460-3-60	414-506	7.5 (5.59)	15.0	19.0	30
	575-3-60	518-632	7.5 (5.59)	10.0	13.0	20

See: "Legend and Notes for Tables 1 – 4" on page 30.

Table 2 – Electrical Data, Alternate Motors with Factory-Installed Single Speed Fan Option

UNIT	V-PH-Hz†	VOLTAGE LIMITS	FAN MOTOR		POWER SUPPLY	
			Hp (kW)	FLA	Minimum Circuit Amps	MAX FUSE or HACR BRKR
072	208/230-1-60	187-253	2.4 (1.79)	11.00	13.80	20
	208/230-3-60	187-253	2.9 (2.16)	7.5	10.0	15
	460-36-0	414-506	2.9 (2.16)	3.4	5.0	15
	575-3-60	518-632	2.0 (1.49)	2.40	3.0	15
091	208/230-1-60	187-253	2.4 (1.79)	11.00	13.80	15
	208/230-3-60	187-253	2.9 (2.16)	7.5	10.0	15
	460-3-60	414-506	2.9 (2.16)	3.4	5.0	15
	575-3-60	518-632	3.0 (2.24)	3.80	5.0	15
120	208/230-3-60	187-253	3.7 (2.76)	10.2	13.0	20
	460-3-60	414-506	3.7 (2.76)	4.8	6.0	15
	575-3-60	518-632	3.0 (2.24)	3.80	5.0	15
150	208/230-3-60	187-253	3.7 (2.76)	10.2	13.0	20
	460-3-60	414-506	3.7 (2.76)	4.8	6.0	15
	575-3-60	518-632	5.0 (3.73)	8.0	10.0	15
180	208/230-3-60	187-253	5.0 (3.73)	18.0	23.0	40
	460-3-60	414-506	5.0 (3.73)	9.1	12.0	20
	575-3-60	518-632	5.0 (3.73)	8.0	10.0	15
240	208/230-3-60	187-253	7.5 (5.59)	23.5	30.0	50
	460-3-60	414-506	7.5 (5.59)	15.0	19.0	30
	575-3-60	518-632	7.5 (5.59)	10.0	13.0	20
300	208/230-3-60	187-253	10.0 (7.46)	32.0	40.0	70
	460-3-60	414-506	10.0 (7.46)	16.0	20.0	35
	575-3-60	518-632	10.0 (7.46)	13.0	17.0	30

See: "Legend and Notes for Tables 1 – 4" on page 30.

Table 3 – Electrical Data, Standard Motors with Factory-Installed 2-Speed Fan Option

UNIT	V-PH-Hz†	VOLTAGE LIMITS	FAN MOTOR		POWER SUPPLY	
			Hp (kW)	FLA	Minimum Circuit Amps	MAX FUSE or HACR BRKR
072	208/230-3-60	187-253	2.4 (1.79)	7.1	9.0	15
	460-3-60	414-506	2.4 (1.79)	3.8	5.0	15
	575-3-60	518-632	2.4 (1.79)	3.5	5.0	15
091	208/230-3-60	187-253	2.4 (1.79)	7.1	9.0	15
	460-3-60	414-506	2.4 (1.79)	3.8	5.0	15
	575-3-60	518-632	2.4 (1.79)	3.5	5.0	15
120	208/230-3-60	187-253	2.4 (1.79)	7.1	9.0	15
	460-3-60	414-506	2.4 (1.79)	3.8	5.0	15
	575-3-60	518-632	2.4 (1.79)	3.5	5.0	15
150	208/230-3-60	187-253	2.9 (2.16)	8.6	11.0	15
	460-3-60	414-506	2.9 (2.16)	3.8	5.0	15
	575-3-60	518-632	3.7 (2.76)	4.5	6.0	15
180	208/230-3-60	187-253	3.7 (2.76)	10.8	14.0	20
	460-3-60	414-506	3.7 (2.76)	4.9	7.0	15
	575-3-60	518-632	3.7 (2.76)	4.5	6.0	15
240	208/230-3-60	187-253	5.0 (3.73)	18.0	23.0	40
	460-3-60	414-506	5.0 (3.73)	9.1	12.0	20
	575-3-60	518-632	5.0 (3.73)	8.0	10.0	15
300	208/230-3-60	187-253	7.5 (5.59)	23.5	30.0	50
	460-3-60	414-506	7.5 (5.59)	15.0	19.0	30
	575-3-60	518-632	7.5 (5.59)	10.0	13.0	20

See: "Legend and Notes for Tables 1 – 4" on page 30.

Table 4 – Electrical Data, Alternate Motors with Factory-Installed 2-Speed Fan Option

UNIT	V-PH-Hz†	VOLTAGE LIMITS	FAN MOTOR		POWER SUPPLY	
			Hp (kW)	FLA	Minimum Circuit Amps	MAX FUSE or HACR BRKR
072	208/230-3-60	187-253	3.7 (2.76)	10.8	14.0	20
	460-36-0	414-506	3.7 (2.76)	4.9	7.0	15
	575-3-60	518-632	3.7 (2.76)	4.5	6.0	15
091	208/230-3-60	187-253	3.7 (2.76)	10.8	14.0	20
	460-3-60	414-506	3.7 (2.76)	4.9	7.0	15
	575-3-60	518-632	3.7 (2.76)	4.5	6.0	15
120	208/230-3-60	187-253	3.7 (2.76)	10.8	14.0	20
	460-3-60	414-506	3.7 (2.76)	4.9	7.0	15
	575-3-60	518-632	3.7 (2.76)	4.5	6.0	15
150	208/230-3-60	187-253	3.7 (2.76)	10.8	14.0	20
	460-3-60	414-506	3.7 (2.76)	4.9	7.0	15
	575-3-60	518-632	5.0 (3.73)	8.0	10.0	15
180	208/230-3-60	187-253	5.0 (3.73)	18.0	23.0	40
	460-3-60	414-506	5.0 (3.73)	9.1	12.0	20
	575-3-60	518-632	5.0 (3.73)	8.0	10.0	15
240	208/230-3-60	187-253	7.5 (5.59)	23.5	30.0	50
	460-3-60	414-506	7.5 (5.59)	15.0	19.0	30
	575-3-60	518-632	7.5 (5.59)	10.0	13.0	20
300	208/230-3-60	187-253	10.0 (7.46)	32.0	40.0	70
	460-3-60	414-506	10.0 (7.46)	16.0	20.0	35
	575-3-60	518-632	10.0 (7.46)	13.0	17.0	25

See: "Legend and Notes for Tables 1 – 4" on page 30.

Legend and Notes for Tables 1 – 4

LEGEND:

FLA – Full Load Amps

MOCP – MAX FUSE or HACR BRKR

† Motors are designed for satisfactory operation within 10% of normal voltage shown. Voltages should not exceed the limits shown in the Voltage Limits column.

NOTES:

- Minimum circuit amps (MCA) and fuse or HACR breaker values are calculated in accordance with The NEC, Article 440.
- Motor FLA values are established in accordance with Underwriters' Laboratories (UL), Standard 1995.
- Unbalanced 3-Phase Supply Voltage**
Never operate a motor where a phase imbalance in supply voltage is greater than 2%. Use the formula in the example (see column to the right) to determine the percentage of voltage imbalance.
- Installation with Accessory Electric Heaters
Size the Field Power Wiring between the heater TB1 and the FAS indoor fan motor per NEC Article 430-28 (1) or (2) (depends on length of conduit between heater enclosure and FAS power entry location). Install wires in field-installed conduit.

Example: Supply voltage is 230-3-60

$$\% \text{ Voltage Imbalance} = 100 \times \frac{\text{max voltage deviation from average voltage}}{\text{average voltage}}$$



AB = 393 v
BC = 403 v
AC = 396 v

$$\begin{aligned} \text{Average Voltage} &= \frac{(393 + 403 + 396)}{3} = \frac{1192}{3} \\ &= 397 \end{aligned}$$

Determine maximum deviation from average voltage.

(AB) 397 – 393 = 4 v

(BC) 403 – 397 = 6 v

(AC) 397 – 396 = 1 v

Maximum deviation is 4 v.

Determine percent of voltage imbalance.

$$\begin{aligned} \% \text{ Voltage Imbalance} &= 100 \times \frac{6}{397} \\ &= 1.5\% \end{aligned}$$

This amount of phase imbalance is satisfactory as it is below the maximum allowable 2%.

IMPORTANT: If the supply voltage phase imbalance is more than 2%, contact your local electric utility company immediately.



Table 5 – Electric Heater Data – Single Speed Motor

HEATER PART NO. CAELHEAT	SIZE	V-PH-Hz	FAN MOTOR			ELECTRIC HEATER(S)					MCA*	MOCP*
			Hp	kW	FLA	Nom. Cap. (kW)	Actual Capacity (kW)			FLA		
							Stage 1	Stage 2	Total			
001A00	FAS 072-120	208-3-60	1.3†	0.97	6.6	5.0	3.8	-	3.76	10.4	21.3	25
			2.4†	1.79	11.0	5.0	3.8	-	3.76	10.4	26.8	35
			2.4	1.79	5.2	5.0	3.8	-	3.76	10.4	19.5	20
			2.9	2.16	7.5	5.0	3.8	-	3.76	10.4	22.4	25
			3.7	2.76	10.2	5.0	3.8	-	3.76	10.4	25.8	30
		240-3-60	1.3†	0.97	6.6	5.0	5.0	-	5.0	12.0	23.3	25
			2.4†	1.79	11.0	5.0	5.0	-	5.0	12.0	28.8	35
			2.4	1.79	5.2	5.0	5.0	-	5.0	12.0	21.5	25
			2.9	2.16	7.5	5.0	5.0	-	5.0	12.0	24.4	25
			3.7	2.76	10.2	5.0	5.0	-	5.0	12.0	27.8	30
002A00	480-3-60	2.4	1.79	2.6	5.0	5.0	-	5.0	6.0	10.8	15	
		2.9	2.16	3.4	5.0	5.0	-	5.0	6.0	11.8	15	
		3.7	2.76	4.8	5.0	5.0	-	5.0	6.0	13.5	15	
003A00	575-3-60	1.0	0.75	1.4	5.0	5.0	-	5.0	5.0	8.0	15	
		2.0	1.49	2.4	5.0	5.0	-	5.0	5.0	9.3	15	
		3.0	2.24	3.8	5.0	5.0	-	5.0	5.0	11.0	15	
004A00	FAS 072-120	208-3-60	1.3†	0.97	6.6	10.0	7.5	-	7.51	20.8	34.3	35
			2.4†	1.79	11.0	10.0	7.5	-	7.51	20.8	39.8	40
			2.4	1.79	5.2	10.0	7.5	-	7.51	20.8	32.6	35
			2.9	2.16	7.5	10.0	7.5	-	7.51	20.8	35.4	40
			3.7	2.76	10.2	10.0	7.5	-	7.51	20.8	38.8	40
		240-3-60	1.3†	0.97	6.6	10.0	10.0	-	10.0	24.1	38.3	40
			2.4†	1.79	11.0	10.0	10.0	-	10.0	24.1	43.8	50
			2.4	1.79	5.2	10.0	10.0	-	10.0	24.1	36.6	40
			2.9	2.16	7.5	10.0	10.0	-	10.0	24.1	39.4	40
			3.7	2.76	10.2	10.0	10.0	-	10.0	24.1	42.8	50
005A00	480-3-60	2.4	1.79	2.6	10.0	10.0	-	10.0	12.0	18.3	20	
		2.9	2.16	3.4	10.0	10.0	-	10.0	12.0	19.3	20	
		3.7	2.76	4.8	10.0	10.0	-	10.0	12.0	21.0	25	
006A00	575-3-60	1.0	0.75	1.4	10.0	10.0	-	10.0	10.0	14.3	15	
		2.0	1.49	2.4	10.0	10.0	-	10.0	10.0	15.6	20	
		3.0	2.24	3.8	10.0	10.0	-	10.0	10.0	17.3	20	
007A00	FAS 072-120	208-3-60	1.3†	0.97	6.6	15.0	11.3	-	11.27	31.3	47.4	50
			2.4†	1.79	11.0	15.0	11.3	-	11.27	31.3	52.9	60
			2.4	1.79	5.2	15.0	11.3	-	11.27	31.3	45.6	50
			2.9	2.16	7.5	15.0	11.3	-	11.27	31.3	48.5	50
			3.7	2.76	10.2	15.0	11.3	-	11.27	31.3	51.9	60
		240-3-60	1.3†	0.97	6.6	15.0	15.0	-	15.0	36.1	53.4	60
			2.4†	1.79	11.0	15.0	15.0	-	15.0	36.1	58.9	60
			2.4	1.79	5.2	15.0	15.0	-	15.0	36.1	51.6	60
			2.9	2.16	7.5	15.0	15.0	-	15.0	36.1	54.5	60
			3.7	2.76	10.2	15.0	15.0	-	15.0	36.1	57.9	60

See: "Legend and Notes for Tables 5 and 6" on page 39.

Table 5 – Electric Heater Data – Single Speed Motor (cont.)

HEATER PART NO. CAELHEAT	SIZE	V-PH-Hz	FAN MOTOR			ELECTRIC HEATER(S)					MCA*	MOCP*	
						Nom. Cap. (kW)	Actual Capacity (kW)			FLA			
			Hp	kW	FLA		Stage 1	Stage 2	Total				
008A00	FAS 072-120	480-3-60	2.4	1.79	2.6	15.0	15.0	-	15.0	18.0	25.8	30	
			2.9	2.16	3.4	15.0	15.0	-	15.0	18.0	26.8	30	
			3.7	2.76	4.8	15.0	15.0	-	15.0	18.0	28.6	30	
009A00		575-3-60	1.0	0.75	1.4	15.0	15.0	-	15.0	15.1	20.6	25	
			2.0	1.49	2.4	15.0	15.0	-	15.0	15.1	21.8	25	
			3.0	2.24	3.8	15.0	15.0	-	15.0	15.1	23.6	25	
010A00		FAS 072-120	208-3-60	1.3†	0.97	6.6	25.0	11.3	7.5	18.8	52.1	73.4	80
				2.4†	1.79	11.0	25.0	11.3	7.5	18.8	52.1	78.9	80
				2.4	1.79	5.2	25.0	11.3	7.5	18.8	52.1	71.7	80
				2.9	2.16	7.5	25.0	11.3	7.5	18.8	52.1	74.5	80
				3.7	2.76	10.2	25.0	11.3	7.5	18.8	52.1	77.9	80
			240-3-60	1.3†	0.97	6.6	25.0	15.0	10.0	25.0	60.1	83.4	90
	2.4†			1.79	11.0	25.0	15.0	10.0	25.0	60.1	88.9	90	
	2.4			1.79	5.2	25.0	15.0	10.0	25.0	60.1	81.7	90	
	2.9			2.16	7.5	25.0	15.0	10.0	25.0	60.1	84.6	90	
	3.7			2.76	10.2	25.0	15.0	10.0	25.0	60.1	87.9	90	
	011A00		480-3-60	2.4	1.79	2.6	25.0	15.0	10.0	25.0	30.1	40.8	50
				2.9	2.16	3.4	25.0	15.0	10.0	25.0	30.1	41.8	50
3.7		2.76		4.8	25.0	15.0	10.0	25.0	30.1	43.6	50		
012A00	575-3-60	1.0	0.75	1.4	25.0	15.0	10.0	25.0	25.1	33.1	35		
		2.0	1.49	2.4	25.0	15.0	10.0	25.0	25.1	34.4	35		
		3.0	2.24	3.8	25.0	15.0	10.0	25.0	25.1	36.1	40		
013A00	FAS 091, 120	208-3-60	2.4†	1.79	11.0	35.0	15.0	11.3	26.3	73.0	105.0	110	
			2.4	1.79	5.2	35.0	15.0	11.3	26.3	73.0	97.7	100	
			2.9	2.16	7.5	35.0	15.0	11.3	26.3	73.0	100.6	110	
			3.7	2.76	10.2	35.0	15.0	11.3	26.3	73.0	104.0	110	
		240-3-60	2.4†	1.79	11.0	35.0	20.0	15.0	35.0	84.2	119.0	125	
			2.4	1.79	5.2	35.0	20.0	15.0	35.0	84.2	111.7	125	
			2.9	2.16	7.5	35.0	20.0	15.0	35.0	84.2	114.6	125	
014A00		480-3-60	3.7	2.76	10.2	35.0	20.0	15.0	35.0	84.2	118.0	125	
			2.4	1.79	2.6	35.0	20.0	15.0	35.0	42.1	55.9	60	
			2.9	2.16	3.4	35.0	20.0	15.0	35.0	42.1	56.9	60	
015A00		575-3-60	3.7	2.76	4.8	35.0	20.0	15.0	35.0	42.1	58.6	60	
			2.0	1.49	2.4	35.0	20.0	15.0	35.0	35.1	46.9	50	
			3.0	2.24	3.8	35.0	20.0	15.0	35.0	35.1	48.7	50	

See: "Legend and Notes for Tables 5 and 6" on page 39.

Table 5 – ELECTRIC HEATER DATA – SINGLE SPEED MOTOR (cont.)

HEATER PART NO. CAELHEAT	SIZE	V-PH-Hz	FAN MOTOR			ELECTRIC HEATER(S)					MCA*	MOCP*	
			Hp	kW	FLA	Nom. Cap. (kW)	Actual Capacity (kW)			FLA			
							Stage 1	Stage 2	Total				
016A00	FAS 150, 180, 240	208-3-60	2.9	2.16	7.5	10.0	7.5	-	7.5	20.8	35.4	40	
			3.7	2.76	10.2	10.0	7.5	-	7.5	20.8	38.8	40	
			5.0	3.73	18.0	10.0	7.5	-	7.5	20.8	48.6	60	
			7.5	5.59	23.5	10.0	7.5	-	7.5	20.8	55.4	70	
		240-3-60	2.9	2.16	7.5	10.0	10.0	-	10.0	24.1	39.4	40	
			3.7	2.76	10.2	10.0	10.0	-	10.0	24.1	42.8	50	
			5.0	3.73	18.0	10.0	10.0	-	10.0	24.1	52.6	60	
			7.5	5.59	23.5	10.0	10.0	-	10.0	24.1	59.4	70	
		017A00	480-3-60	2.9	2.16	3.4	10.0	10.0	-	10.0	12.0	19.3	20
				3.7	2.76	4.8	10.0	10.0	-	10.0	12.0	21.0	25
				5.0	3.73	9.1	10.0	10.0	-	10.0	12.0	26.4	30
				7.5	5.59	15.0	10.0	10.0	-	10.0	12.0	33.8	40
018A00	575-3-60	3.0	2.24	3.8	10.0	10.0	-	10.0	10.0	17.3	20		
		5.0	3.73	8.0	10.0	10.0	-	10.0	10.0	22.6	25		
		7.5	5.59	10.0	10.0	10.0	-	10.0	10.0	25.1	30		
019A00	208-3-60	2.9	2.16	7.5	20.0	14.9	-	15.0	41.7	61.5	70		
		3.7	2.76	10.2	20.0	14.9	-	15.0	41.7	64.9	70		
		5.0	3.73	18.0	20.0	14.9	-	15.0	41.7	74.6	80		
		7.5	5.59	23.5	20.0	14.9	-	15.0	41.7	81.5	90		
	240-3-60	2.9	2.16	7.5	20.0	19.9	-	20.0	48.1	69.5	70		
		3.7	2.76	10.2	20.0	19.9	-	20.0	48.1	72.9	80		
		5.0	3.73	18.0	20.0	19.9	-	20.0	48.1	82.6	90		
		7.5	5.59	23.5	20.0	19.9	-	20.0	48.1	89.5	100		
020A00	480-3-60	2.9	2.16	3.4	20.0	20.0	-	20.0	24.1	34.3	35		
		3.7	2.76	4.8	20.0	20.0	-	20.0	24.1	36.1	40		
		5.0	3.73	9.1	20.0	20.0	-	20.0	24.1	41.4	50		
		7.5	5.59	15.0	20.0	20.0	-	20.0	24.1	48.8	50		
021A00	575-3-60	3.0	2.24	3.8	20.0	20.0	-	20.0	20.1	29.9	30		
		5.0	3.73	8.0	20.0	20.0	-	20.0	20.1	35.1	40		
		7.5	5.59	10.0	20.0	20.0	-	20.0	20.1	37.6	40		
022A00	208-3-60	2.9	2.16	7.5	30.0	15.0	7.5	22.5	62.5	87.5	90		
		3.7	2.76	10.2	30.0	15.0	7.5	22.5	62.5	90.9	100		
		5.0	3.73	18.0	30.0	15.0	7.5	22.5	62.5	100.7	110		
		7.5	5.59	23.5	30.0	15.0	7.5	22.5	62.5	107.5	110		
	240-3-60	2.9	2.16	7.5	30.0	20.0	10.0	30.0	72.2	99.6	100		
		3.7	2.76	10.2	30.0	20.0	10.0	30.0	72.2	103.0	110		
		5.0	3.73	18.0	30.0	20.0	10.0	30.0	72.2	112.7	125		
		7.5	5.59	23.5	30.0	20.0	10.0	30.0	72.2	119.6	125		
023A00	480-3-60	2.9	2.16	3.4	30.0	20.0	10.0	30.0	36.1	49.4	50		
		3.7	2.76	4.8	30.0	20.0	10.0	30.0	36.1	51.1	60		
		5.0	3.73	9.1	30.0	20.0	10.0	30.0	36.1	56.5	60		
		7.5	5.59	15.0	30.0	20.0	10.0	30.0	36.1	63.9	70		
024A00	575-3-60	3.0	2.24	3.8	30.0	20.0	10.0	30.0	30.1	42.4	50		
		5.0	3.73	8.0	30.0	20.0	10.0	30.0	30.1	47.7	50		
		7.5	5.59	10.0	30.0	20.0	10.0	30.0	30.1	50.2	60		
025A00	208-3-60	3.7	2.76	10.2	50.0	22.6	15.0	37.6	104.3	143.1	150		
		5.0	3.73	18.0	50.0	22.6	15.0	37.6	104.3	152.8	175		
		7.5	5.59	23.5	50.0	22.6	15.0	37.6	104.3	159.7	175		
	240-3-60	3.7	2.76	10.2	50.0	30.0	20.0	50.0	120.3	163.1	175		
		5.0	3.73	18.0	50.0	30.0	20.0	50.0	120.3	172.9	175		
026A00	480-3-60	3.7	2.76	4.8	50.0	30.0	20.0	50.0	60.1	81.2	90		
		5.0	3.73	9.1	50.0	30.0	20.0	50.0	60.1	86.6	90		
		7.5	5.59	15.0	50.0	30.0	20.0	50.0	60.1	93.9	100		
027A00	575-3-60	3.0	2.24	3.8	50.0	30.0	20.0	50.0	50.2	67.5	70		
		5.0	3.73	8.0	50.0	30.0	20.0	50.0	50.2	72.8	80		
		7.5	5.59	10.0	50.0	30.0	20.0	50.0	50.2	75.3	80		

See: "Legend and Notes for Tables 5 and 6" on page 39.

Table 5 – ELECTRIC HEATER DATA – SINGLE SPEED MOTOR (cont.)

HEATER PART NO. CAELHEAT	SIZE	V-PH-Hz	FAN MOTOR			ELECTRIC HEATER(S)					MCA*	MOCP*
						Nom. Cap. (kW)	Actual Capacity (kW)			FLA		
			Hp	kW	FLA		Stage 1	Stage 2	Total			
028A00		208-3-60	7.5	5.59	23.5	20.0	14.9	-	15.0	41.7	81.5	90
			10.0	7.46	32.0	20.0	14.9	-	15.0	41.7	92.1	110
		240-3-60	7.5	5.59	23.5	20.0	19.9	-	20.0	48.1	89.5	100
			10.0	7.46	32.0	20.0	19.9	-	20.0	48.1	100.1	110
029A00		480-3-60	7.5	5.59	15.0	20.0	20.0	-	20.0	24.1	48.8	50
			10.0	7.46	16.0	20.0	20.0	-	20.0	24.1	50.1	60
030A00		575-3-60	7.5	5.59	10.0	20.0	20.0	-	20.0	20.1	37.6	40
			10.0	7.46	13.0	20.0	20.0	-	20.0	20.1	41.4	50
031A00		208-3-60	7.5	5.59	23.5	40.0	15.0	15.0	30.0	83.4	133.6	150
			10.0	7.46	32.0	40.0	15.0	15.0	30.0	83.4	144.2	150
		240-3-60	7.5	5.59	23.5	40.0	20.0	20.0	40.0	96.2	149.7	150
			10.0	7.46	32.0	40.0	20.0	20.0	40.0	96.2	160.3	175
032A00		480-3-60	7.5	5.59	15.0	40.0	20.0	20.0	40.0	48.1	78.9	80
			10.0	7.46	16.0	40.0	20.0	20.0	40.0	48.1	80.1	90
033A00	FAS 300	575-3-60	7.5	5.59	10.0	40.0	20.0	20.0	40.0	40.2	62.7	70
			10.0	7.46	13.0	40.0	20.0	20.0	40.0	40.2	66.5	70
034A00		208-3-60	7.5	5.59	23.5	50.0	22.6	15.0	37.6	104.3	159.7	175
			10.0	7.46	32.0	50.0	22.6	15.0	37.6	104.3	170.3	175
		240-3-60	7.5	5.59	23.5	50.0	30.0	20.0	50.0	120.3	179.7	200
			10.0	7.46	32.0	50.0	30.0	20.0	50.0	120.3	190.4	200
035A00		480-3-60	7.5	5.59	15.0	50.0	30.0	20.0	50.0	60.1	93.9	100
			10.0	7.46	16.0	50.0	30.0	20.0	50.0	60.1	95.2	100
036A00		575-3-60	7.5	5.59	10.0	50.0	30.0	20.0	50.0	50.2	75.3	80
			10.0	7.46	13.0	50.0	30.0	20.0	50.0	50.2	79.0	80
037A00		208-3-60	7.5	5.59	23.5	70.0	30.0	22.6	52.6	145.9	175.3	200
			10.0	7.46	32.0	70.0	30.0	22.6	52.6	145.9	185.9	200
		240-3-60	7.5	5.59	23.5	70.0	40.0	30.0	70.0	168.4	197.8	225
			10.0	7.46	32.0	70.0	40.0	30.0	70.0	168.4	208.4	225
038A00		480-3-60	7.5	5.59	15.0	70.0	40.0	30.0	70.0	84.2	102.9	110
			10.0	7.46	16.0	70.0	40.0	30.0	70.0	84.2	104.2	110
039A00		575-3-60	7.5	5.59	10.0	70.0	40.0	30.0	70.0	70.3	82.8	90
			10.0	7.46	13.0	70.0	40.0	30.0	70.0	70.3	86.5	90

See: "Legend and Notes for Tables 5 and 6" on page 39.

Table 6 – Electric Heater Data – 2-Speed Motor

HEATER-PART NO.-CAELHEAT	SIZE	V-Ph-Hz	FAN MOTOR			ELECTRIC HEATER(S)					MCA*	MOCP*
						Nom. Cap. (kW)	Actual Capacity			FLA		
			HP	kW	FLA		Stage 1	Stage 2	Total			
001A00	FAS 072-120	208-3-60	1.7	1.27	5.8	5.0	3.8	-	3.8	10.4	20.3	25
			2.4	1.79	7.1	5.0	3.8	-	3.8	10.4	21.9	25
			3.7	2.76	10.8	5.0	3.8	-	3.8	10.4	26.5	30
			3.7**	2.76	10.6	5.0	3.8	-	3.8	10.4	26.3	30
		240-3-60	1.7	1.27	5.6	5.0	5.0	-	5.0	12.0	22.0	25
			2.4	1.79	7.1	5.0	5.0	-	5.0	12.0	23.9	25
			3.7	2.76	10.8	5.0	5.0	-	5.0	12.0	28.5	35
			3.7**	2.76	10.6	5.0	5.0	-	5.0	12.0	28.3	35
002A00	480-3-60	1.7	1.27	2.9	5.0	5.0	-	5.0	6.0	11.1	15	
		2.4	1.79	3.8	5.0	5.0	-	5.0	6.0	12.3	15	
		3.7	2.76	4.9	5.0	5.0	-	5.0	6.0	13.6	15	
		3.7**	2.76	5.3	5.0	5.0	-	5.0	6.0	14.1	15	
003A00	575-3-60	1.7	1.27	2.8	5.0	5.0	-	5.0	5.0	9.8	15	
		2.4	1.79	3.5	5.0	5.0	-	5.0	5.0	10.7	15	
		3.7	2.76	4.5	5.0	5.0	-	5.0	5.0	11.9	15	
004A00	208-3-60	1.7	1.27	5.8	10.0	7.5	-	7.5	20.8	33.3	35	
		2.4	1.79	7.1	10.0	7.5	-	7.5	20.8	34.9	35	
		3.7	2.76	10.8	10.0	7.5	-	7.5	20.8	39.6	40	
		3.7**	2.76	10.6	10.0	7.5	-	7.5	20.8	39.3	40	
	240-3-60	1.7	1.27	5.6	10.0	10.0	-	10.0	24.1	37.1	40	
		2.4	1.79	7.1	10.0	10.0	-	10.0	24.1	38.9	40	
		3.7	2.76	10.8	10.0	10.0	-	10.0	24.1	43.6	50	
		3.7**	2.76	10.6	10.0	10.0	-	10.0	24.1	43.3	50	
005A00	480-3-60	1.7	1.27	2.9	10.0	10.0	-	10.0	12.0	18.7	20	
		2.4	1.79	3.8	10.0	10.0	-	10.0	12.0	19.8	20	
		3.7	2.76	4.9	10.0	10.0	-	10.0	12.0	21.2	25	
		3.7**	2.76	5.3	10.0	10.0	-	10.0	12.0	21.7	25	
006A00	575-3-60	1.7	1.27	2.8	10.0	10.0	-	10.0	10.0	16.1	20	
		2.4	1.79	3.5	10.0	10.0	-	10.0	10.0	16.9	20	
		3.7	2.76	4.5	10.0	10.0	-	10.0	10.0	18.2	20	
007A00	208-3-60	1.7	1.27	5.8	15.0	11.3	-	11.3	31.3	46.4	50	
		2.4	1.79	7.1	15.0	11.3	-	11.3	31.3	48.0	50	
		3.7	2.76	10.8	15.0	11.3	-	11.3	31.3	52.6	60	
		3.7**	2.76	10.6	15.0	11.3	-	11.3	31.3	52.4	60	
	240-3-60	1.7	1.27	5.6	15.0	15.0	-	15.0	36.1	52.1	60	
		2.4	1.79	7.1	15.0	15.0	-	15.0	36.1	54.0	60	
		3.7	2.76	10.8	15.0	15.0	-	15.0	36.1	58.6	60	
		3.7**	2.76	10.6	15.0	15.0	-	15.0	36.1	58.4	60	
008A00	480-3-60	1.7	1.27	2.9	15.0	15.0	-	15.0	18.0	26.2	30	
		2.4	1.79	3.8	15.0	15.0	-	15.0	18.0	27.3	30	
		3.7	2.76	4.9	15.0	15.0	-	15.0	18.0	28.7	30	
		3.7**	2.76	5.3	15.0	15.0	-	15.0	18.0	29.2	30	
009A00	575-3-60	1.7	1.27	2.8	15.0	15.0	-	15.0	15.1	22.3	25	
		2.4	1.79	3.5	15.0	15.0	-	15.0	15.1	23.2	25	
		3.7	2.76	4.5	15.0	15.0	-	15.0	15.1	24.5	25	
010A00	208-3-60	1.7	1.27	5.8	25.0	11.3	7.5	18.8	52.1	72.4	80	
		2.4	1.79	7.1	25.0	11.3	7.5	18.8	52.1	74.0	80	
		3.7	2.76	10.8	25.0	11.3	7.5	18.8	52.1	78.7	80	
		3.7**	2.76	10.6	25.0	11.3	7.5	18.8	52.1	78.4	80	
	240-3-60	1.7	1.27	5.6	25.0	15.0	10.0	25.0	60.1	82.2	90	
		2.4	1.79	7.1	25.0	15.0	10.0	25.0	60.1	84.1	90	
		3.7	2.76	10.8	25.0	15.0	10.0	25.0	60.1	88.7	90	
		3.7**	2.76	10.6	25.0	15.0	10.0	25.0	60.1	88.4	90	

See: "Legend and Notes for Tables 5 and 6" on page 39.

Table 6 – ELECTRIC HEATER DATA – 2–SPEED MOTOR (cont.)

HEATER PART NO. CAELHEAT	SIZE	V-PH-Hz	FAN MOTOR			ELECTRIC HEATER(S)					MCA*	MOCP*	
						Nom. Cap. (kW)	Actual Capacity (kW)			FLA			
			Hp	kW	FLA		Stage 1	Stage 2	Total				
011A00	FAS 072–120	480–3–60	1.7	1.27	2.9	25.0	15.0	10.0	25.0	30.1	41.2	50	
			2.4	1.79	3.8	25.0	15.0	10.0	25.0	30.1	42.3	50	
			3.7	2.76	4.9	25.0	15.0	10.0	25.0	30.1	43.7	50	
			3.7**	2.76	5.3	25.0	15.0	10.0	25.0	30.1	44.2	50	
012A00		575–3–60	1.7	1.27	2.8	25.0	15.0	10.0	25.0	25.1	34.9	35	
			2.4	1.79	3.5	25.0	15.0	10.0	25.0	25.1	35.8	40	
			3.7	2.76	4.5	25.0	15.0	10.0	25.0	25.1	37.0	40	
013A00		208–3–60	1.7	1.27	5.8	35.0	15.0	11.3	26.3	73.0	98.5	100	
			2.4	1.79	7.1	35.0	15.0	11.3	26.3	73.0	100.1	110	
			3.7	2.76	10.8	35.0	15.0	11.3	26.3	73.0	104.7	110	
			3.7**	2.76	10.6	35.0	15.0	11.3	26.3	73.0	104.5	110	
		240–3–60	1.7	1.27	5.6	35.0	20.0	15.0	35.0	84.2	112.2	125	
	2.4		1.79	7.1	35.0	20.0	15.0	35.0	84.2	114.1	125		
	3.7		2.76	10.8	35.0	20.0	15.0	35.0	84.2	118.7	125		
	3.7**		2.76	10.6	35.0	20.0	15.0	35.0	84.2	118.5	125		
014A00	FAS 072–120	480–3–60	1.7	1.27	2.9	35.0	20.0	15.0	35.0	42.1	56.2	60	
			2.4	1.79	3.8	35.0	20.0	15.0	35.0	42.1	57.4	60	
			3.7	2.76	4.9	35.0	20.0	15.0	35.0	42.1	58.7	60	
			3.7**	2.76	5.3	35.0	20.0	15.0	35.0	42.1	59.2	60	
015A00		575–3–60	1.7	1.27	2.8	35.0	20.0	15.0	35.0	35.1	47.4	50	
			2.4	1.79	3.5	35.0	20.0	15.0	35.0	35.1	48.3	50	
			3.7	2.76	4.5	35.0	20.0	15.0	35.0	35.1	49.6	50	
016A00		FAS 150	208–3–60	2.9	2.16	8.6	10.0	7.5	–	7.5	20.8	36.8	40
				3.7	2.76	10.8	10.0	7.5	–	7.5	20.8	39.6	40
		FAS 180	208–3–60	3.7	2.76	10.8	10.0	7.5	–	7.5	20.8	39.6	40
				5.0	3.73	18.0	10.0	7.5	–	7.5	20.8	48.6	60
		FAS 240	208–3–60	5.0	3.73	18.0	10.0	7.5	–	7.5	20.8	48.6	60
	7.5			5.59	23.5	10.0	7.5	–	7.5	20.8	55.4	70	
	FAS 150	240–3–60	2.9	2.16	8.6	10.0	10.0	–	10.0	24.1	40.8	50	
			3.7	2.76	10.8	10.0	10.0	–	10.0	24.1	43.6	50	
	FAS 180	240–3–60	3.7	2.76	10.8	10.0	10.0	–	10.0	24.1	43.6	50	
			5.0	3.73	18.0	10.0	10.0	–	10.0	24.1	52.6	60	
	FAS 240	240–3–60	5.0	3.73	18.0	10.0	10.0	–	10.0	24.1	52.6	60	
			7.5	5.59	23.5	10.0	10.0	–	10.0	24.1	59.4	70	
017A00	FAS 150	480–3–60	2.9	2.16	3.8	10.0	10.0	–	10.0	12.0	19.8	20	
			3.7	2.76	4.9	10.0	10.0	–	10.0	12.0	21.2	25	
	FAS 180	480–3–60	3.7	2.76	4.9	10.0	10.0	–	10.0	12.0	21.2	25	
			5.0	3.73	9.1	10.0	10.0	–	10.0	12.0	26.4	30	
	FAS 240	480–3–60	5.0	3.73	9.1	10.0	10.0	–	10.0	12.0	26.4	30	
			7.5	5.59	15.0	10.0	10.0	–	10.0	12.0	33.8	40	
018A00	FAS 150	575–3–60	3.7	2.76	4.5	10.0	10.0	–	10.0	10.0	18.2	20	
			5.0	3.73	8.0	10.0	10.0	–	10.0	10.0	22.6	25	
	FAS 180	575–3–60	3.7	2.76	4.5	10.0	10.0	–	10.0	10.0	18.2	20	
			5.0	3.73	8.0	10.0	10.0	–	10.0	10.0	22.6	25	
	FAS 240	575–3–60	5.0	3.73	8.0	10.0	10.0	–	10.0	10.0	22.6	25	
			7.5	5.59	10.0	10.0	10.0	–	10.0	10.0	25.1	30	

See: "Legend and Notes for Tables 5 and 6" on page 39.

Table 6 – ELECTRIC HEATER DATA – 2–SPEED MOTOR (cont.)

HEATER PART NO. CAELHEAT	SIZE	V-PH-Hz	FAN MOTOR			ELECTRIC HEATER(S)					MCA*	MOCP*
						Nom. Cap. (kW)	Actual Capacity (kW)			FLA		
			Hp	kW	FLA		Stage 1	Stage 2	Total			
019A00	FAS 150	208–3–60	2.9	2.16	8.6	20.0	15.0	–	15.0	41.7	62.9	70
			3.7	2.76	10.8	20.0	15.0	–	15.0	41.7	65.6	70
	FAS 180	208–3–60	3.7	2.76	10.8	20.0	15.0	–	15.0	41.7	65.6	70
			5.0	3.73	18.0	20.0	15.0	–	15.0	41.7	74.6	80
	FAS 240	208–3–60	5.0	3.73	18.0	20.0	15.0	–	15.0	41.7	74.6	80
			7.5	5.59	23.5	20.0	15.0	–	15.0	41.7	81.5	90
	FAS 150	240–3–60	2.9	2.16	8.6	20.0	20.0	–	20.0	48.1	70.9	80
			3.7	2.76	10.8	20.0	20.0	–	20.0	48.1	73.6	80
	FAS 180	240–3–60	3.7	2.76	10.8	20.0	20.0	–	20.0	48.1	73.6	80
			5.0	3.73	18.0	20.0	20.0	–	20.0	48.1	82.6	90
	FAS 240	240–3–60	5.0	3.73	18.0	20.0	20.0	–	20.0	48.1	82.6	90
			7.5	5.59	23.5	20.0	20.0	–	20.0	48.1	89.5	100
020A00	FAS 150	480–3–60	2.9	2.16	3.8	20.0	19.9	–	20.0	24.1	34.8	35
			3.7	2.76	4.9	20.0	19.9	–	20.0	24.1	36.2	40
	FAS 180	480–3–60	3.7	2.76	4.9	20.0	19.9	–	20.0	24.1	36.2	40
			5.0	3.73	9.1	20.0	19.9	–	20.0	24.1	41.4	50
	FAS 240	480–3–60	5.0	3.73	9.1	20.0	19.9	–	20.0	24.1	41.4	50
			7.5	5.59	15.0	20.0	19.9	–	20.0	24.1	48.8	50
021A00	FAS 150	575–3–60	3.7	2.76	4.5	20.0	20.0	–	20.0	20.1	30.7	35
			5.0	3.73	8.0	20.0	20.0	–	20.0	20.1	35.1	40
	FAS 180	575–3–60	3.7	2.76	4.5	20.0	20.0	–	20.0	20.1	30.7	35
			5.0	3.73	8.0	20.0	20.0	–	20.0	20.1	35.1	40
	FAS 240	575–3–60	5.0	3.73	8.0	20.0	20.0	–	20.0	20.1	35.1	40
			7.5	5.59	10.0	20.0	20.0	–	20.0	20.1	37.6	40
022A00	FAS 150	208–3–60	2.9	2.16	8.6	30.0	15.0	7.5	22.5	62.5	88.9	90
			3.7	2.76	10.8	30.0	15.0	7.5	22.5	62.5	91.7	100
	FAS 180	208–3–60	3.7	2.76	10.8	30.0	15.0	7.5	22.5	62.5	91.7	100
			5.0	3.73	18.0	30.0	15.0	7.5	22.5	62.5	100.7	110
	FAS 150	240–3–60	2.9	2.16	8.6	30.0	20.0	10.0	30.0	72.2	101.0	110
			3.7	2.76	10.8	30.0	20.0	10.0	30.0	72.2	103.7	110
	FAS 180	240–3–60	3.7	2.76	10.8	30.0	20.0	10.0	30.0	72.2	103.7	110
			5.0	3.73	18.0	30.0	20.0	10.0	30.0	72.2	112.7	125
	FAS 240	208–3–60	5.0	3.73	18.0	30.0	15.0	7.5	22.5	62.5	100.7	110
			7.5	5.59	23.5	30.0	15.0	7.5	22.5	62.5	107.5	110
		240–3–60	5.0	3.73	18.0	30.0	20.0	10.0	30.0	72.2	112.7	125
			7.5	5.59	23.5	30.0	20.0	10.0	30.0	72.2	119.6	125
023A00	FAS 150	480–3–60	2.9	2.16	3.8	30.0	20.0	10.0	30.0	36.1	49.9	50
			3.7	2.76	4.9	30.0	20.0	10.0	30.0	36.1	51.2	60
	FAS 180	480–3–60	3.7	2.76	4.9	30.0	20.0	10.0	30.0	36.1	51.2	60
			5.0	3.73	9.1	30.0	20.0	10.0	30.0	36.1	56.5	60
	FAS 240	480–3–60	5.0	3.73	9.1	30.0	20.0	10.0	30.0	36.1	56.5	60
			7.5	5.59	15.0	30.0	20.0	10.0	30.0	36.1	63.9	70
024A00	FAS 150	575–3–60	3.7	2.76	4.5	30.0	20.0	10.0	30.0	30.1	43.3	50
			5.0	3.73	8.0	30.0	20.0	10.0	30.0	30.1	47.7	50
	FAS 180	575–3–60	3.7	2.76	4.5	30.0	20.0	10.0	30.0	30.1	43.3	50
			5.0	3.73	8.0	30.0	20.0	10.0	30.0	30.1	47.7	50
	FAS 240	575–3–60	5.0	3.73	8.0	30.0	20.0	10.0	30.0	30.1	47.7	50
			7.5	5.59	10.0	30.0	20.0	10.0	30.0	30.1	50.2	60
025A00	FAS 180	208–3–60	3.7	2.76	10.8	50.0	22.6	15.0	37.6	104.3	143.8	150
			5.0	3.73	18.0	50.0	22.6	15.0	37.6	104.3	152.8	175
	FAS 240	208–3–60	5.0	3.73	18.0	50.0	22.6	15.0	37.6	104.3	152.8	175
			7.5	5.59	23.5	50.0	22.6	15.0	37.6	104.3	159.7	175
	FAS 180	240–3–60	3.7	2.76	10.8	50.0	30.0	20.0	50.0	120.3	163.9	175
			5.0	3.73	18.0	50.0	30.0	20.0	50.0	120.3	172.9	175
FAS 240	240–3–60	5.0	3.73	18.0	50.0	30.0	20.0	50.0	120.3	172.9	175	
		7.5	5.59	23.5	50.0	30.0	20.0	50.0	120.3	179.7	200	

See: "Legend and Notes for Tables 5 and 6" on page 39.

Table 6 – ELECTRIC HEATER DATA – 2–SPEED MOTOR (cont.)

HEATER PART NO. CAELHEAT	SIZE	V-PH-Hz	FAN MOTOR			ELECTRIC HEATER(S)					MCA*	MOCP*
						Nom. Cap. (kW)	Actual Capacity (kW)			FLA		
			Hp	kW	FLA		Stage 1	Stage 2	Total			
026A00	FAS 180	480–3–60	3.7	2.76	4.9	50.0	30.0	20.0	50.0	60.1	81.3	90
			5.0	3.73	9.1	50.0	30.0	20.0	50.0	60.1	86.6	90
	FAS 240	480–3–60	5.0	3.73	9.1	50.0	30.0	20.0	50.0	60.1	86.6	90
			7.5	5.59	15.0	50.0	30.0	20.0	50.0	60.1	93.9	100
027A00	FAS 180	575–3–60	3.7	2.76	4.5	50.0	30.0	20.0	50.0	50.2	68.4	70
			5.0	3.73	8.0	50.0	30.0	20.0	50.0	50.2	72.8	80
	FAS 240	575–3–60	5.0	3.73	8.0	50.0	30.0	20.0	50.0	50.2	72.8	80
			7.5	5.59	10.0	50.0	30.0	20.0	50.0	50.2	75.3	80
028A00	FAS 300	208–3–60	7.5	5.59	23.5	20.0	15.0	–	15.0	41.7	81.5	90
		240–3–60	7.5	5.59	23.5	20.0	20.0	–	20.0	48.1	89.5	100
		208–3–60	10.0	7.46	32.0	20.0	15.0	–	15.0	41.7	92.1	110
		240–3–60	10.0	7.46	32.0	20.0	20.0	–	20.0	48.1	100.1	110
029A00	FAS 300	480–3–60	7.5	5.59	15.0	20.0	20.0	–	20.0	24.1	48.8	50
			10.0	7.46	16.0	20.0	20.0	–	20.0	24.1	50.1	60
030A00	FAS 300	575–3–60	7.5	5.59	10.0	20.0	20.0	–	20.0	20.1	37.6	40
			10.0	7.46	13.0	20.0	20.0	–	20.0	20.1	41.4	50
031A00	FAS 300	208–3–60	7.5	5.59	23.5	40.0	15.0	15.0	30.0	83.4	133.6	150
			10.0	7.46	32.0	40.0	15.0	15.0	30.0	83.4	144.2	150
	FAS 300	208–3–60	7.5	5.59	23.5	40.0	20.0	20.0	30.0	83.4	133.6	150
			10.0	7.46	32.0	40.0	20.0	20.0	30.0	83.4	144.2	150
032A00	FAS 300	480–3–60	7.5	5.59	15.0	40.0	20.0	20.0	40.0	48.1	78.9	80
			10.0	7.46	16.0	40.0	20.0	20.0	40.0	48.1	80.1	90
033A00	FAS 300	575–3–60	7.5	5.59	10.0	40.0	20.0	20.0	40.0	40.2	62.7	70
			10.0	7.46	13.0	40.0	20.0	20.0	40.0	40.2	66.5	70
034A00	FAS 300	208–3–60	7.5	5.59	23.5	50.0	22.6	15.0	37.6	104.3	159.7	175
			10.0	7.46	32.0	50.0	22.6	15.0	37.6	104.3	170.3	175
	FAS 300	208–3–60	7.5	5.59	23.5	50.0	30.0	20.0	37.6	104.3	159.7	175
			10.0	7.46	32.0	50.0	30.0	20.0	37.6	104.3	170.3	175
035A00	FAS 300	480–3–60	7.5	5.59	15.0	50.0	30.0	20.0	50.0	60.1	93.9	100
			10.0	7.46	16.0	50.0	30.0	20.0	50.0	60.1	95.2	100
036A00	FAS 300	575–3–60	7.5	5.59	10.0	50.0	30.0	20.0	50.0	50.2	75.3	80
			10.0	7.46	13.0	50.0	30.0	20.0	50.0	50.2	79.0	80
037A00	FAS 300	208–3–60	7.5	5.59	23.5	70.0	30.0	22.6	52.6	145.9	175.3	200
			10.0	7.46	32.0	70.0	30.0	22.6	52.6	145.9	185.9	200
	FAS 300	240–3–60	7.5	5.59	23.5	70.0	40.0	30.0	70.0	168.4	197.8	225
			10.0	7.46	32.0	70.0	40.0	30.0	70.0	168.4	208.4	225
038A00	FAS 300	480–3–60	7.5	5.59	15.0	70.0	40.0	30.0	70.0	84.2	102.9	110
			10.0	7.46	16.0	70.0	40.0	30.0	70.0	84.2	104.2	110
039A00	FAS 300	575–3–60	7.5	5.59	10.0	70.0	40.0	30.0	70.0	70.3	82.8	90
			10.0	7.46	13.0	70.0	40.0	30.0	70.0	70.3	86.5	90

See: "Legend and Notes for Tables 5 and 6" on page 39.

Legend and Notes for Tables 5 and 6

LEGEND

- FLA** — Full Load Amps
Hp — Horsepower
MCA — Minimum Circuit Amps
MOCP — Maximum Overcurrent Protection (Amps)

** High Efficiency Motor

* Values shown are for single-point connection of electric heat accessory and air handler.

† Single-phase motors. All other motors are 3-phase.

NOTES:

- Electrical resistance heaters are rated at 240 v, 480 v, or 575 v. To determine heater capacity (kW) at unit nameplate multiply the 240-v, 480-v, or 575-v capacity (kW) by the factor shown in the table below for the unit voltage.

HEATER RATING VOLTAGE	ACTUAL HEATER VOLTAGE										
	200	208	230	240	400	440	460	480	550	575	600
240	0.694	0.751	0.918	1	—	—	—	—	—	—	—
480	—	—	—	—	0.694	0.84	0.918	1	—	—	—
575	—	—	—	—	—	—	—	—	0.915	1	1.089

- The following equation converts kW of heat energy to Btuh: kW x 3,412 = Btuh.
- Heater contactor coils are 24 v and require 8 va holding current.
- Electric heaters are tested and ETL approved at maximum total external static pressure of 1.9 in. wg.
- MCA and MOCP values apply to both standard and alternate factory-supplied motors.
- Approximate shipping weight for CAELHEAT001A00-015A00 is 55 lb (25 kg) each. Approximate shipping weight for CAELHEAT016A00-027A00 is 60 lb (27 kg) each, and CAELHEAT028A00-039A00 is 75 lb (34 kg) each.



TYPICAL PIPING AND WIRING

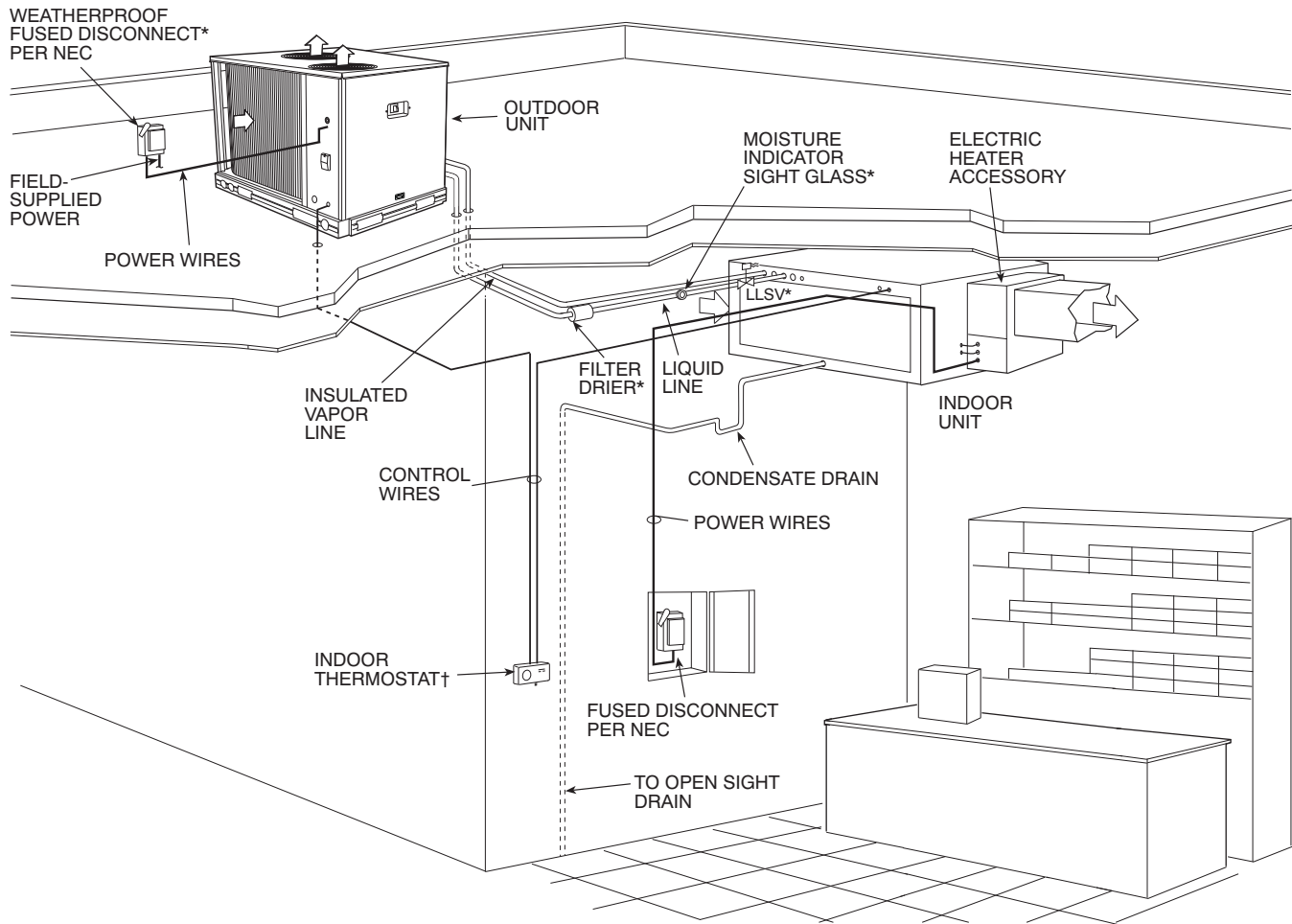

C09054

LEGEND:

NEC — National Electrical Code

TXV — Thermostatic Expansion Valve

* Field-supplied

† Double riser may be required. Consult condensing unit product data catalog for details.

NOTES:

1. All piping must follow standard refrigerant piping techniques.
2. All wiring must comply with the applicable local and national codes.
3. Wiring and piping shown are general points-of-connection guides only and are not intended for, or to include all details for, a specific installation.
4. Liquid line solenoid valve (solenoid drop control) is recommended to prevent refrigerant migration to the compressor.
5. Internal factory-supplied TXVs not shown.

TYPICAL PIPING AND WIRING (cont.)

VERTICAL INSTALLATION (TYPICAL)

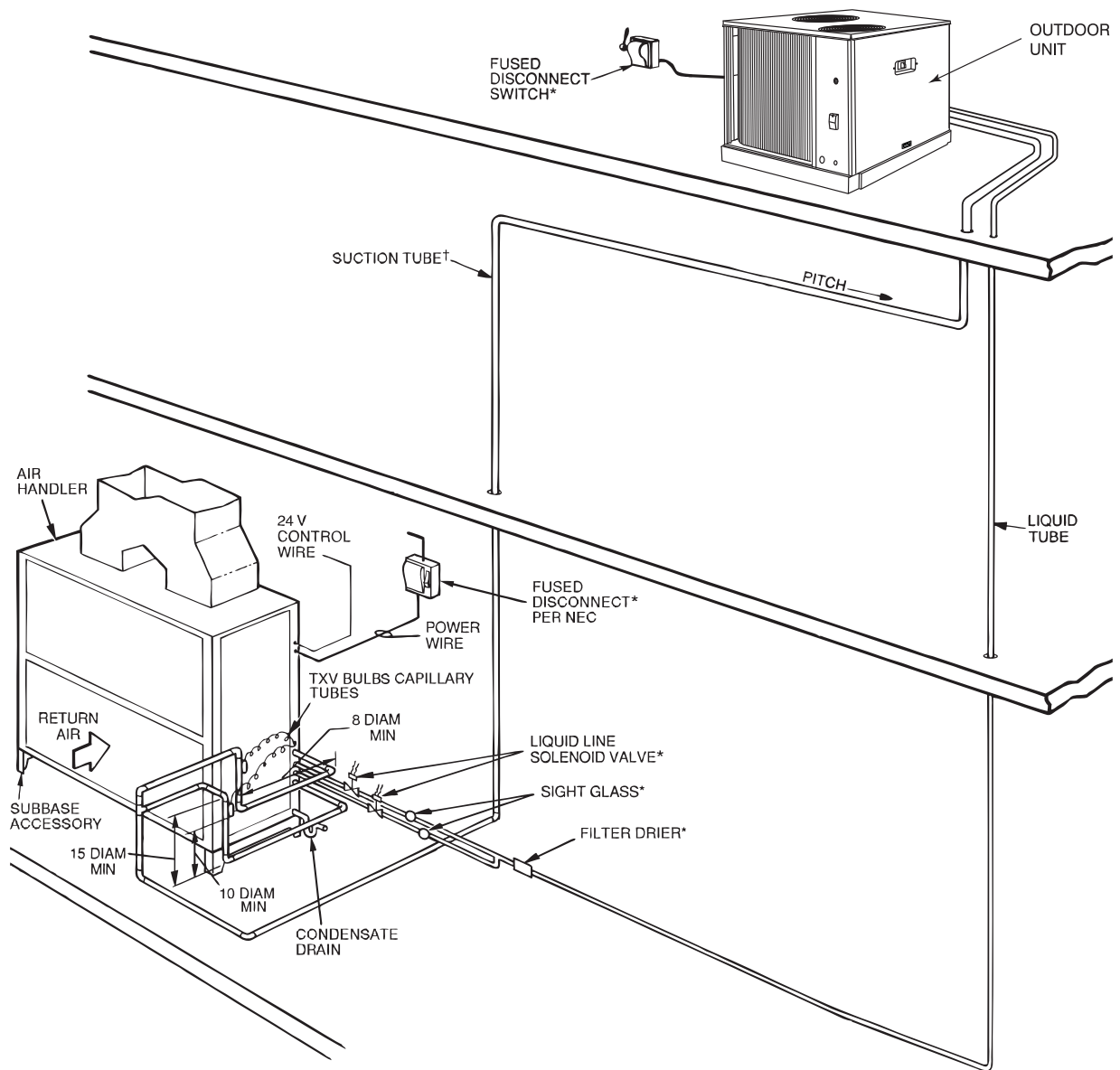

C150280

LEGEND:

- LLSV – Liquid Line Solenoid Valve
- NEC – National Electrical Code
- TXV – Thermostatic Expansion Valve

* Field-supplied

† Double riser may be required Consult condensing unit product data catalog for details.

NOTES:

1. All piping must follow standard refrigerant piping techniques.
2. All wiring must comply with the applicable local and national codes.
3. Wiring and piping shown are general points-of-connection guides only and are not intended for, or to include all details for, a specific installation.
4. Liquid line solenoid valve (solenoid drop control) is recommended to prevent refrigerant migration to the compressor.
5. Internal factory-supplied TXVs not shown.

TYPICAL PIPING AND WIRING (cont.)

WIRE ROUTING, BASE UNIT

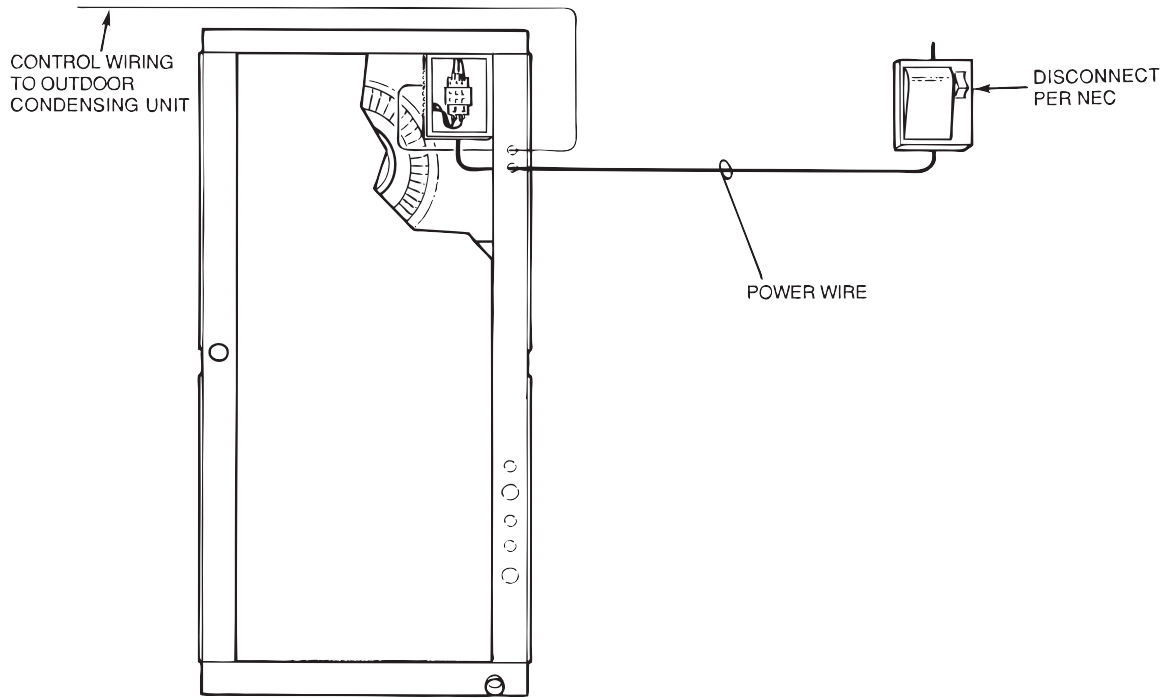

WIRE ROUTING, UNIT WITH ELECTRIC HEAT

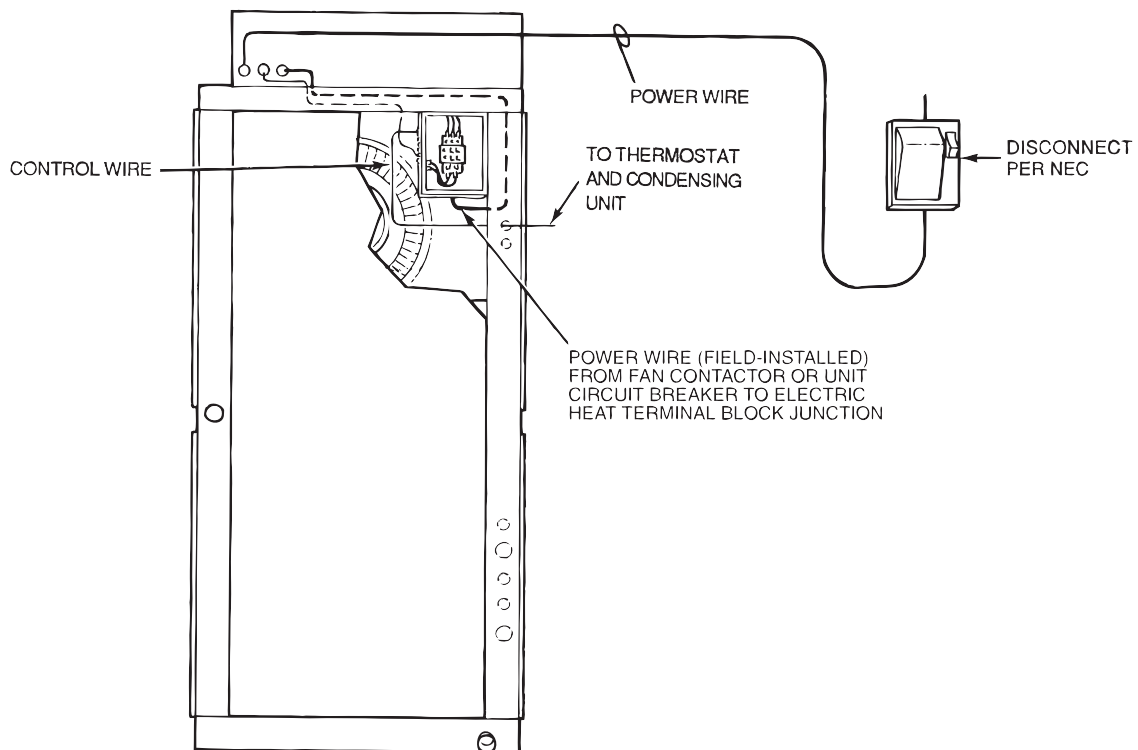

C150279

TYPICAL CONTROL WIRING SCHEMATIC

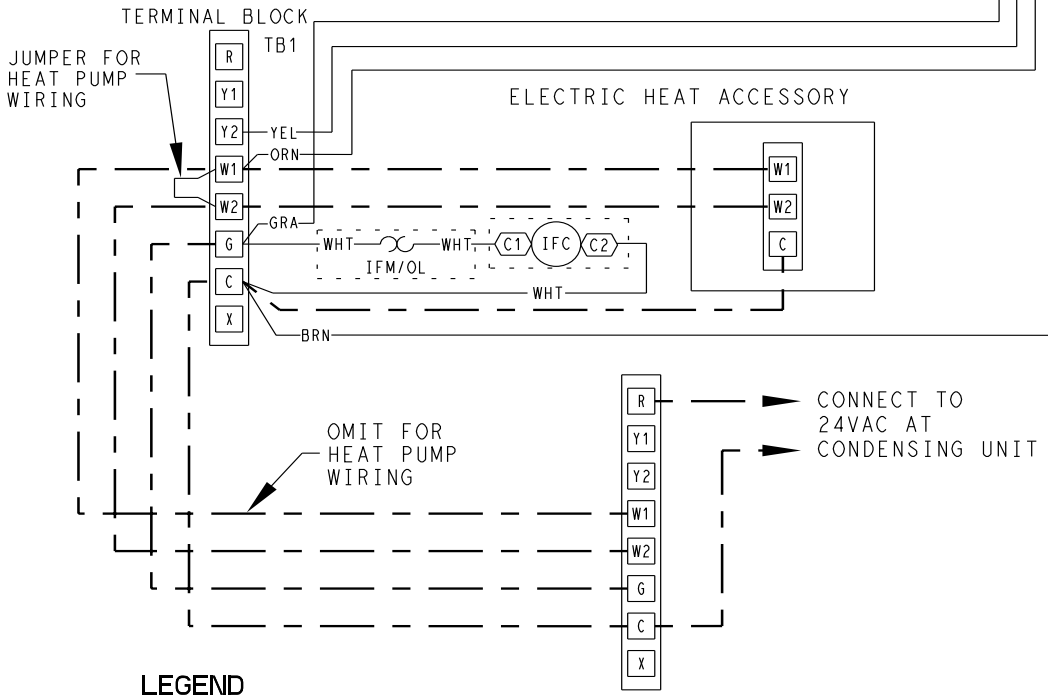
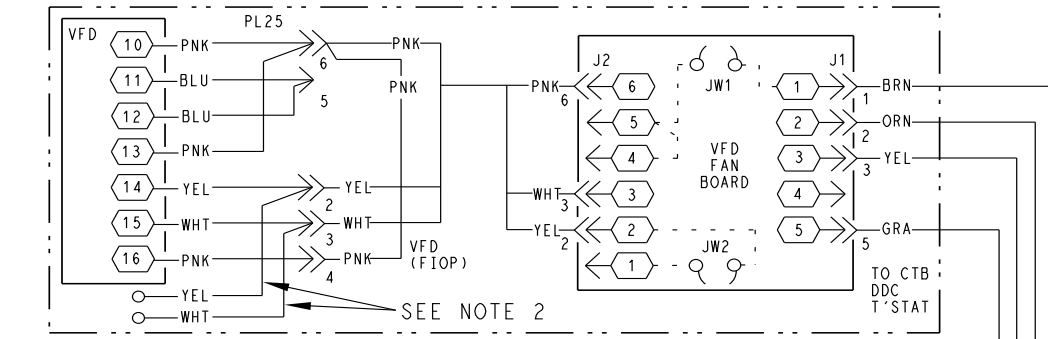
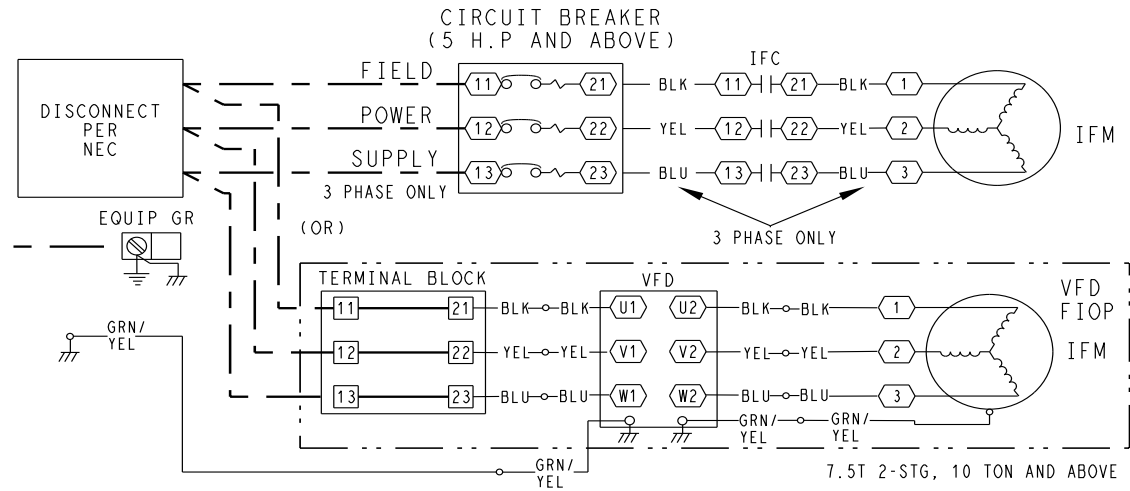

LEGEND

- FACTORY WIRING
- - - - - FIELD CONTROL WIRING
- CB CIRCUIT BREAKER
- IFC INDOOR FAN CONTACTOR
- IFM INDOOR FAN MOTOR
- TB TERMINAL BLOCK
- T'STAT THERMOSTAT
- VFD VARIABLE FREQUENCY DRIVE

- NOTES:
1. USE COPPER CONDUCTORS ONLY.
 2. FOR HIGH SPEED BLOWER TESTING, CONNECT YELLOW AND WHITE WIRES. DISCONNECT FOR NORMAL OPERATION.

40RM501370 H

C150249

APPLICATION DATA

General

IMPORTANT: Do not bury refrigerant piping underground.

Select equipment to match or to be slightly less than peak load. This provides better humidity control, less unit cycling, and less part-load operation. Equipment should be selected to perform at no less than 300 cfm/ton (40 L/s per kW).

The air handler fan must always be operating when the condensing unit is operating.

Ductwork should be sized according to unit size, not building load. For larger units with two fans, a split duct transition is recommended at the fan outlets, but a plenum can be used with slight reduction in external static pressure capability.

AUXILIARY SIDE CONNECTOR DATA

UNIT	P/N	INLET/OUTLET DIAMETER — ODF (in.)	AUXILIARY (Hot Gas) DIAMETER — ODF (in.)
072	1178747	1 ¹ / ₈	5 ⁵ / ₈
091	1178748	1 ³ / ₈	7 ⁷ / ₈
120	1178747	1 ¹ / ₈	5 ⁵ / ₈
150	1178747	1 ¹ / ₈	5 ⁵ / ₈
180	1178747	1 ¹ / ₈	5 ⁵ / ₈
240	1178747	1 ¹ / ₈	5 ⁵ / ₈
300	1178748	1 ³ / ₈	7 ⁷ / ₈

FACTORY-INSTALLED NOZZLE AND DISTRIBUTOR DATA

UNIT	COIL TYPE	TXV Qty...Part No.*	DISTRIBUTOR Qty...Part No.†	FEEDER TUBES PER DISTRIBUTOR Qty...Size (in.)	NOZZLE Qty...Part No.
072	4 Row	1...TDEBX8	1...1116	12... ¹ / ₄	1...E5
091	4 Row	1...TDEBX8	1...1126	15... ¹ / ₄	1...C6
120	4 Row	2...TDEX6	2...1115	9... ¹ / ₄	2...E4
150	4 Row	2...TDEBX8	2...1115	12... ³ / ₁₆	2...E5
180	4 Row	2...TDEBX8	2...1126	16... ¹ / ₄	2...C6
240	4 Row	2...TDEBX11	2...1126	18... ³ / ₁₆	2...C8
300	4 Row	2...TDEBX11	2...1126	20... ³ / ₁₆	2...C15

LEGEND

TXV — Thermostatic Expansion Valve

* Danfoss part numbers shown.

† Sporlan Valve Co. part numbers shown.

NOTE: Hot gas bypass applications require field-supplied auxiliary side connector.

APPLICATION DATA (cont.)

FAN MOTOR DATA STANDARD MOTOR Single Speed

FAS UNIT	072	091	120	150	180	240	300
208/230-1-60							
Speed (rpm)	1725	1725	—	—	—	—	—
Hp	1.3	2.4	—	—	—	—	—
Frame (NEMA)	56Y	56Y	—	—	—	—	—
Shaft Dia (in.)	$\frac{5}{8}$	$\frac{5}{8}$	—	—	—	—	—
230-3-60 and 460-3-60							
Speed (rpm)	1750	1750	1750	1750	1750	1755	1760
Hp	2.4	2.4	2.4	2.9	3.7	5.0	7.5
Frame (NEMA)	56Y	56Y	56Y	56Y	56HZ	184T	S213T
Shaft Dia (in.)	$\frac{5}{8}$	$\frac{5}{8}$	$\frac{5}{8}$	$\frac{7}{8}$	$\frac{7}{8}$	$1\frac{1}{8}$	$1\frac{3}{8}$
575-3-60							
Speed (rpm)	1725	1725	1725	1725	1725	1755	1750
Hp	1.0	2.0	2.0	3.0	3.0	5.0	7.5
Frame (NEMA)	56	56HZ	56HZ	56HZ	56HZ	184T	S213T
Shaft Dia (in.)	$\frac{5}{8}$	$\frac{7}{8}$	$\frac{7}{8}$	$\frac{7}{8}$	$\frac{7}{8}$	$1\frac{1}{8}$	$1\frac{3}{8}$

LEGEND:

NEMA — National Electrical Manufacturers Association (U.S.A.)

FAN MOTOR DATA ALTERNATE MOTOR Single Speed

FAS UNIT	072	091	120	150	180	240	300
208/230-1-60							
Speed (rpm)	1725	1725	—	—	—	—	—
Hp	2.4	2.4	—	—	—	—	—
Frame (NEMA)	56Y	56Y	—	—	—	—	—
Shaft Dia (in.)	$\frac{5}{8}$	$\frac{5}{8}$	—	—	—	—	—
230-3-60 and 460-3-60							
Speed (rpm)	1750	1750	1750	1750	1755	1760	1755
Hp	2.9	2.9	3.7	3.7	5.0	7.5	10.0
Frame (NEMA)	56Y	56Y	56HZ	56HZ	184T	S213T	S215T
Shaft Dia (in.)	$\frac{7}{8}$	$\frac{7}{8}$	$\frac{7}{8}$	$\frac{7}{8}$	$1\frac{1}{8}$	$1\frac{3}{8}$	$1\frac{3}{8}$
575-3-60							
Speed (rpm)	1725	1725	1725	1745	1745	1755	1750
Hp	2.0	3.0	3.0	5.0	5.0	7.5	10.0
Frame (NEMA)	56HZ	56HZ	56HZ	184T	184T	S213T	S215T
Shaft Dia (in.)	$\frac{7}{8}$	$\frac{7}{8}$	$\frac{7}{8}$	$1\frac{1}{8}$	$1\frac{1}{8}$	$1\frac{3}{8}$	$1\frac{3}{8}$

LEGEND:

NEMA — National Electrical Manufacturers Association (U.S.A.)

MOTOR EFFICIENCY FAS

MOTOR HP	EPACT MINIMUM	MOTOR EFFICIENCY
1.3*	—	70%
2.4	—	76.8%
2.9	—	77.1%
3.7	—	81.5%
5.0	89.5%	89.5%
7.5	91.7%	91.7%
10.0	91.7%	91.7%

LEGEND:

EPACT — Energy Policy and Conservation Act of 1992

* Single-phase only.

APPLICATION DATA (cont.)

FAN MOTOR DATA STANDARD MOTOR Two Speed

FAS UNIT	091	120	150	180	240	300
208/230-3-60 and 460-3-60						
Speed (rpm)	1680	1680	1735	1750	1755	1760
Hp	2.4	2.4	2.9	3.7	5.0	7.5
Frame (NEMA)	56HY	56HY	56HY	56HY	184T	S213T
Shaft Dia (in.)	5/8	5/8	7/8	7/8	1 1/8	1 3/8
575-3-60						
Speed (rpm)	1680	1680	1710	1710	1755	1750
Hp	2.4	2.4	3.7	3.7	5.0	7.5
Frame (NEMA)	56HY	56HY	56HY	56HY	184T	S213T
Shaft Dia (in.)	5/8	5/8	7/8	7/8	1 1/8	1 3/8

FAN MOTOR DATA ALTERNATE MOTOR Two Speed

FAS UNIT	091	120	150	180	240	300
208/230-3-60 and 460-3-60						
Speed (rpm)	1750	1750	1750	1755	1760	1755
Hp	3.7	3.7	3.7	5.0	7.5	10.0
Frame (NEMA)	56HY	56HY	56HY	184T	S213T	S215T
Shaft Dia (in.)	7/8	7/8	7/8	1 1/8	1 3/8	1 3/8
575-3-60						
Speed (rpm)	1710	1710	1755	1755	1750	1755
Hp	3.7	3.7	5.0	5.0	7.5	10.0
Frame (NEMA)	56HY	56HY	184T	184T	S213T	S215T
Shaft Dia (in.)	7/8	7/8	1 1/8	1 1/8	1 3/8	1 3/8

MOTOR EFFICIENCY FAS – Two Speed Motor

MOTOR HP	EPACT MINIMUM	MOTOR EFFICIENCY
2.4	–	80.0%
2.9	–	86.5%
3.7	–	83.6%
5.0	89.5%	89.5%
7.5	91.7%	91.7%
10.0	91.7%	91.7%

LEGEND:

EPACT – Energy Policy and Conservation Act of 1992

APPLICATION DATA (cont.)

STANDARD DRIVE DATA, 60 Hz

FAS UNIT	072	091	120	150	180	240	300
MOTOR DRIVE							
Motor Pulley Pitch Diameter (in.)	2.4-3.4	2.8-3.8	3.4-4.4	2.8-3.8	2.8-3.8	3.7-4.7	4.3-5.3
Pulley Factory Setting Full Turns Open	2.5	2.5	2.5	2.5	2.5	3.0	3.0
FAN DRIVE							
Pulley Pitch Dia (in.)	8.8	8.8	8.8	9.0	9.0	9.4	11.0
Pulley Bore (in.)	1	1	1	1 ⁷ / ₁₆	1 ⁷ / ₁₆	1 ⁷ / ₁₆	1 ¹⁵ / ₁₆
Belt No. — Section	1—A	1—A	1—A	1—A	1—A	1—B	2—B [†]
Belt Pitch (in.)	40.3	41.3	42.3	42.3	42.3	41.8	(2) 42.8 (2) 43.8
FAN SPEEDS (rpm)							
Factory Settings	568	647	764	632	632	771	752
Range	470-666	549-745	666-863	537-728	537-728	679-863	682-841
Max Allowable Speed (rpm)	1200	1200	1200	1200	1200	1200	1100
Change per 1/2 turn of Moveable Motor Pulley Flange	19.6	19.6	19.7	19.1	19.1	15.3	13.1
MAX FULL TURNS FROM CLOSED POSITION	5	5	5	5	5	6	6
SHAFTS CENTER DISTANCE (in.)	10.44-12.32					9.12-10.99	6.67-9.43

† Four belts shipped with unit. Use correct set of 2 belts sized according to the pulley setting.

MEDIUM-STATIC DRIVE DATA, 60 Hz

FAS UNIT	072	091	120	150	180	240	300
MOTOR DRIVE							
Motor Pulley Pitch Diameter (in.)	3.4-4.4	3.4-4.4	3.4-4.4	3.4-4.4	3.7-4.7	4.3-5.3	4.3-5.3
Pulley Factory Setting Full Turns Open	2.5	2.5	2.5	2.5	3.0	3.0	3.0
FAN DRIVE							
Pulley Pitch Dia (in.)	8.8	8.0	8.0	8.2	8.6	9.4	9.4
Pulley Bore (in.)	1	1	1	1 ⁷ / ₁₆	1 ⁷ / ₁₆	1 ⁷ / ₁₆	1 ¹⁵ / ₁₆
Belt No. — Section	1—A	1—A	1—A	1—A	1—B	1—B	2—B [†]
Belt Pitch (in.)	42.3	40.3	40.3	41.3	41.8	41.8	(2) 38.8 (2) 39.8
FAN SPEEDS (rpm)							
Factory Setting	764	841	841	820	842	881	881
Range	666-863	733-949	733-949	715-926	742-943	798-984	798-984
Max Allowable Speed (rpm)	1200	1200	1200	1200	1200	1200	1100
Change per 1/2 Turn of Moveable Motor Pulley Flange	19.7	21.6	21.6	21.1	16.7	15.3	15.3
MAX FULL TURNS FROM CLOSED POSITION	5	5	5	5	6	6	6
SHAFTS CENTER DISTANCE (in.)	10.44-12.32					9.16-10.99	6.67-9.43

† Four belts shipped with unit. Use correct set of 2 belts sized according to the pulley setting.

APPLICATION DATA (cont.)

HIGH-STATIC DRIVE DATA, 60 Hz

FAS UNIT	072	091	120	150	180	240	300
MOTOR DRIVE							
Motor Pulley Pitch Diameter (in.)	3.4-4.4	3.4-4.4	3.4-4.4	3.7-4.7	4.3-5.3	4.3-5.3	4.3-5.3
Pulley Factory Setting Full Turns Open	2.5	2.5	2.5	3.0	3.0	3.0	3.0
FAN DRIVE							
Pulley Pitch Dia (in.)	7.0	6.0 [‡]	6.0	7.4	7.9	7.4	8.6
Pulley Bore (in.)	1	1	1	1 ⁷ / ₁₆	1 ⁷ / ₁₆	1 ⁷ / ₁₆	1 ¹⁵ / ₁₆
Belt No. — Section	1—A	1—A	1—A	1—B	1—B	2—B	2—B
Belt Pitch (in.)	41.3	37.3	37.3	39.8	39.8	36.8	37.8
FAN SPEEDS (rpm)							
Factory Setting	961	1121	1121	979	1060	1118	1024
Range	838-1084	978-1200 ^{‡†}	978-1200 [†]	873-1096	950-1171	1014-1200 [†]	873-1075
Max Allowable Speed (rpm)	1200	1200	1200	1200	1200	1200	1100
Change per 1/2 Turn of Moveable Motor Pulley Flange	24.6	28.7	28.7	19.4	18.4	19.4	16.7
MAX FULL TURNS FROM CLOSED POSITION	5	5	5	6	6	6	6
SHAFTS CENTER DISTANCE (in.)	10.44-12.32			10.44-12.32**	9.16-10.99	8.16-10.02	6.67-9.43

[‡] Values for 3-phase motor shown. For single-phase motor, pulley pitch diameter is 7 in. and resulting fan speed is 837-1096 rpm.

[†] It is possible to adjust drive so that fan speed exceeds maximum allowable. DO NOT exceed 1200 rpm.

** 575-v unit has a center distance of 9.16-10.99.

GUIDE SPECIFICATIONS

Commercial Packaged Air-Handling Unit

HVAC Guide Specifications

Size Range: 2,400 to 10,000 Cfm, Nominal Airflow, 6 to 25 Tons, Nominal Cooling

Model Numbers: FAS (Direct-Expansion Coil)

Part 1 — GENERAL

1.01 SYSTEM DESCRIPTION

- A. Indoor, packaged air-handling unit for use in commercial split systems. Unit shall have a multi-position design and shall be capable of horizontal or vertical installation on a floor or in a ceiling, with or without ductwork. (Only vertical units are to be applied without ductwork.)
- B. Unit with direct-expansion coil shall be used in a refrigerant circuit with a matching air-cooled condensing unit.

1.02 QUALITY ASSURANCE

- A. Coils shall be designed and tested in accordance with ASHRAE 15 Safety Code for Mechanical Refrigeration (U.S.A.), latest edition.
- B. Unit shall be constructed in accordance with ETL (U.S.A.) and ETL, Canada, standards and shall carry the ETL and ETL, Canada, labels.
- C. Unit insulation and adhesive shall comply with NFPA-90A (U.S.A.) requirements for flame spread and smoke generation. Insulation shall contain an EPA-registered immobilized antimicrobial agent to effectively resist the growth of bacteria and fungi as proven by tests in accordance with ASTM standards G21 and 22 (U.S.A.).
- D. Unit shall be manufactured in a facility registered to the ISO 9001 manufacturing quality standard.
- E. Direct-expansion coils shall be burst and leak tested at 435 psi.

1.03 DELIVERY AND STORAGE

Units shall be stored and handled per manufacturer's recommendations.

Part 2 — PRODUCTS

2.01 EQUIPMENT

Indoor mounted, draw-thru, packaged air-handling unit that can be used in a suspended horizontal configuration or a vertical configuration. Unit shall consist of forward-curved belt-driven centrifugal fan(s), motor and drive assembly, pre-wired fan motor contactor, factory-installed refrigerant metering devices (direct-expansion coil units), cooling coil, 2-in. (51-mm) disposable air filters, and condensate drain pans for vertical or horizontal configurations.

A. Base Unit:

1. Cabinet shall be constructed of mill-galvanized steel.
2. Cabinet panels shall be fully insulated with $\frac{1}{2}$ -in. (12.7-mm) fire-retardant material. Insulation shall contain an EPA-registered immobilized antimicrobial agent to effectively resist the growth of bacteria and fungi as proven by tests in accordance with ASTM standards G21 and 22 (U.S.A.).
3. Unit shall contain non-corroding condensate drain pans for both vertical and horizontal applications. Drain pans shall have connections on right and left sides of unit to facilitate field connection. Drain pans shall have the ability to be sloped toward the right or left side of the unit to prevent standing water from accumulating in pans.
4. Unit shall have factory-supplied 2-in. (51 mm) throwaway-type filters installed upstream from the cooling coil. Filter access shall be from either the right or left side of the unit.

B. Coils:

DX coil is 4-row and consists of copper tubes with sine-wave aluminum fins bonded to the tubes by mechanical expansion. Suction and liquid line connections or supply and discharge connections shall be made on the same side of the coil.

1. Direct-expansion coils shall feature factory installed thermostatic expansion valves (TXVs) for refrigerant control. The TXVs shall be R-410A compatible and capable of external adjustment. Coil tubing shall be internally rifled to maximize heat transfer. The FAS300 have 1179823 TXVs. These are Sporlan BBIZE-15-GA-BP5 which have a 5% bleed.

C. Operating Characteristics:

1. When combined with matching 569J condensing unit the system shall be capable of starting and running at ambient outdoor temperatures from 35°F (2°C) to 125°F (52°C) in cooling mode and from -10°F (-23°C) to 60°F (16°C) in heating mode.
2. Unit shall operate at +/- 10% from rated voltage.

D. Motor:

1. Fan motor of the size and electrical characteristics specified on the equipment schedule shall be factory supplied and installed.

2. Motors rated at 1.3 through 3.7 hp shall have inherent thermal overload protection. Motors rated at 5 hp shall be protected by a circuit breaker.
 3. Evaporator-fan motor shall have permanently lubricated, sealed bearings and inherent automatic-reset thermal overload protection or manual reset calibrated circuit breakers. Evaporator motors are designed specifically for ICP and do not have conventional horsepower (hp) ratings listed on the motor nameplate. Motors are designed and qualified in the “air-over” location downstream of the cooling coil and carry a maximum continuous bhp rating that is the maximum application bhp rating for the motor; no “safety factors” above that rating may be applied.
 4. All evaporator-fan motors 5 hp and larger shall meet the minimum efficiency requirements as established by the Energy Policy Act of 1992 (EPACT), effective October 24, 1997.
- E. Special Features:
1. Alternate Motor and Drive:
An alternate motor and/or medium-static or high-static drive shall be available to meet the airflow and external static pressure requirements specified on the equipment schedule.
 2. External Paint:
Where conditions require, units shall be painted with an American Sterling Gray finish.
 3. Hot Water Coil:
Coil shall be 2-row, U-bend coil with copper tubes and aluminum plate fins bonded to the tubes by mechanical expansion. Coil shall be mounted in a galvanized steel housing that shall be fastened to the unit’s fan deck for blow-thru heating operation. Coil shall have maximum working pressure of 150 psig.
 4. Steam Distributing Coil:
Coil shall consist of one row of copper tubes with aluminum plate fins, and shall have inner steam distributing tubes. Coil shall be mounted in a galvanized steel housing and shall be fastened to the unit’s fan deck for blow-thru heating operation. Coil shall have maximum working pressure of 20 psig at 260°F.
 5. Electric Heaters:
Heaters for nominal 240, 480, or 575-volt, 3-phase, 60 Hz shall be factory-supplied for field installation as shown on the equipment drawings. Electric heat assembly shall be ETL (U.S.A.) and ETL, Canada, agency approved, and shall have single-point power wiring. Heater assembly shall include contactors with 24-v coils, power wiring, 24-v control wiring terminal blocks, and a hinged access panel. Electric heaters shall not be used with air discharge plenum.
 6. Air Discharge Plenum:
Plenum shall be factory-supplied to provide free-blow air distribution for vertical floor-mounted units. A grille with moveable vanes for horizontal or vertical airflow adjustment shall be included. Plenum shall be field-assembled and field-installed on the unit’s fan deck for blow-thru air distribution. Plenum shall not be used with electric heaters.
 7. Return-Air Grille:
Grille shall be factory-supplied for field installation on the unit’s return air opening.
 8. Unit Subbase:
Subbase assembly shall be factory-supplied for field installation. Subbase shall elevate floor-mounted vertical units to provide access for correct condensate drain connection.
 9. Economizers:
- a. Accessory **Ultra LOW LEAK** EconoMi\$er X. (Field installed)
- Economizer for ventilation or “free” cooling shall be factory provided for field installation on either return air opening of air handler.
- (1.) Integrated, gear driven opposing modulating blade design type capable of simultaneous economizer and compressor operation.
 - (2.) Damper blades shall be galvanized steel with composite gears. Plastic or composite blades on intake or return shall not be acceptable.
 - (3.) Shall include all hardware, actuator and controls to provide free cooling with outdoor air when temperature and/or humidity are below setpoints.
 - (4.) Shall be equipped with gear driven dampers for both the outdoor ventilation air and the return air for positive air stream control
 - (5.) Ultra LOW LEAK design meets California Title 24 section 140.4 and ASHRAE90.1 requirements for 4 cfm per sq.ft. on the outside air dampers and 10 cfm per sq. ft. on the return dampers.
 - (6.) Economizer controller on EconoMi\$er X models shall be the Honeywell W7220 that provides:
 - i. 2--line LCD interface screen for setup, configuration and troubleshooting
 - ii. On--board Fault Detection and Diagnostics (FDD) that senses and alerts when the economizer is not operating properly, per California Title 24.
 - iii. Sensor failure loss of communication identification
 - iv. Automatic sensor detection

- v. Capabilities for use with multiple--speed indoor fan systems
 - vi. Utilizing digital sensors: Dry bulb and Enthalpy. Accessory comes standard with dry bulb sensing.
 - vii. Field installing enthalpy sensor required.
- b. Accessory Standard Leak EconoMi\$er IV (Field installed)
- Economizer for ventilation or "free" cooling shall be factory provided for field installation on either return air opening of air handler.
- (1.) Integrated, gear driven opposing modulating blade design type capable of simultaneous economizer and compressor operation.
 - (2.) Damper blades shall be galvanized steel with composite gears. Plastic or composite blades on intake or return shall not be acceptable.
 - (3.) Shall include all hardware, actuator and controls to provide free cooling with outdoor air when temperature and/or humidity are below setpoints.
 - (4.) Shall be equipped with gear driven dampers for both the outdoor ventilation air and the return air for positive air stream control
 - (5.) Standard leak rate shall be equipped with dampers not to exceed 2% leakage at 1 in. wg pressure differential.
 - (6.) Economizer controller on EconoMi\$er IV models shall be Honeywell W7212 that provides:
 - i. Combined minimum and DCV maximum damper position potentiometers with compressor staging relay.
 - ii. Functions with solid state analog enthalpy or dry bulb changeover control sensing.
 - iii. Contains LED indicates for:
 - when free cooling is available, when module is in DCV mode, when exhaust fan is closed.
10. Overhead Suspension Package:
Package shall include necessary brackets to support units in a horizontal ceiling installation.
11. CO₂ Sensor:
Sensor shall provide the ability to signal the economizer to open when the space CO₂ level exceeds the predetermined setpoint.
12. Condensate Drain Trap:
Trap shall have transparent, serviceable design for easy cleaning. Kit shall include overflow shutoff switch and wiring harness for connection to an alarm if desired.
13. 2-Speed Indoor Fan Motor system for 2-stage cooling models only:
Evaporator fan motor:
Shall have permanently lubricated bearings.
Shall have a maximum continuous bhp rating for continuous duty operation; no safety factors above that rating.
Shall be Variable Frequency duty and 2-speed control.
Shall contain motor shaft grounding ring to prevent electrical bearing fluting damage by safely diverting harmful shaft voltages and bearing currents to ground.
14. Variable Frequency Drive (VFD). Only available on 2-Speed Indoor Fan Motor system units:
Shall be installed inside the unit cabinet, mounted, wired and tested.
Shall contain Electromagnetic Interference (EMI) frequency protection.
Insulated Gate Bi-Polar Transistors (IGBT) used to produce the output pulse width modulated (PWM) waveform, allowing for quiet motor operation.
Self diagnostics with fault and power code LED indicator. Field accessory Display Kit available for further diagnostics and special setup applications.
RS485 capability standard.
Electronic thermal overload protection.
5% swinging chokes for harmonic reduction and improved power factor.
All printed circuit boards shall be conformal coated.

