



Product Specifications

DUCT FREE SPLIT SYSTEM HIGH WALL, R-410A

Efficient 13 SEER Air Conditioners and
7.7 HSPF Heat Pumps

¾ THRU 2 TONS

- Rotary compressors in all models
- Wireless remote for enhanced functionality
- Programmable time/temperature settings
- Sleep mode
- Diagnostics
- Low ambient cooling feature allows safe cooling mode operation down to -20° F outdoor ambient*
- Auto-Swing louvers
- Compressor lockout protection
- 115 volt on ¾ and 1 ton models
- Factory charged with R-410A refrigerant
- 5 year limited compressor, 5 year limited coil and parts warranties



Rated in accordance with ARI Standard 210 and/or 240. Certification applies only when used with proper components as listed with ARI.

*“A” series models (1½–2 ton) offer low ambient kit as an accessory

Air Conditioners		
System Model Number		
Outdoor Section	Size (tons)	Dimensions W x H x D in. (mm)
Indoor Section		
DFS4A309J1B		
DFC4A309J1B	¾	30.71 x 21.26 x 10.87 (780 x 540 x 276)
DFF4AH09J1A	¾	32.09 x 11.02 x 7.68 (815 x 280 x 195)
DFS4A312J1B		
DFC4A312J1B	1	29.92 x 23.23 x 11.42 (760 x 590 x 290)
DFF4AH12J1A	1	35.67 x 11.26 x 9.25 (906 x 286 x 235)
DFS4A318K1B		
DFC4A318K1B	1½	33.07 x 27.36 x 13.19 (840 x 695 x 335)
DFF4AH18K1A	1½	49.21 x 12.80 x 9.06 (1250 x 325 x 230)
DFS4A324K1A		
DFC4A324K1A	2	31.16 x 33.86 x 13.11 (893 x 860 x 333)
DFF4AH24K1A	2	49.21 x 12.80 x 9.06 (1250 x 325 x 230)

Heat Pumps		
System Model Number		
Outdoor Section	Size (tons)	Dimensions W x H x D in. (mm)
Indoor Section		
DFS4H309J1B		
DFC4H309J1B	¾	30.71 x 21.26 x 10.87 (780 x 540 x 276)
DFF4HH09J1A	¾	32.09 x 11.02 x 7.68 (815 x 280 x 195)
DFS4H312J1B		
DFC4H312J1B	1	29.92 x 23.23 x 11.42 (760 x 590 x 290)
DFF4HH12J1A	1	35.67 x 11.26 x 9.25 (906 x 286 x 235)
DFS4H318K1A		
DFC4H318K1A	1½	33.07 x 27.36 x 13.19 (840 x 695 x 335)
DFF4HH18K1A	1½	49.21 x 12.80 x 9.06 (1250 x 325 x 230)
DFS4H324K1A		
DFC4H324K1A	2	31.16 x 33.86 x 13.11 (893 x 860 x 333)
DFF4HH24K1A	2	49.21 x 12.80 x 9.06 (1250 x 325 x 230)

Required Clearances

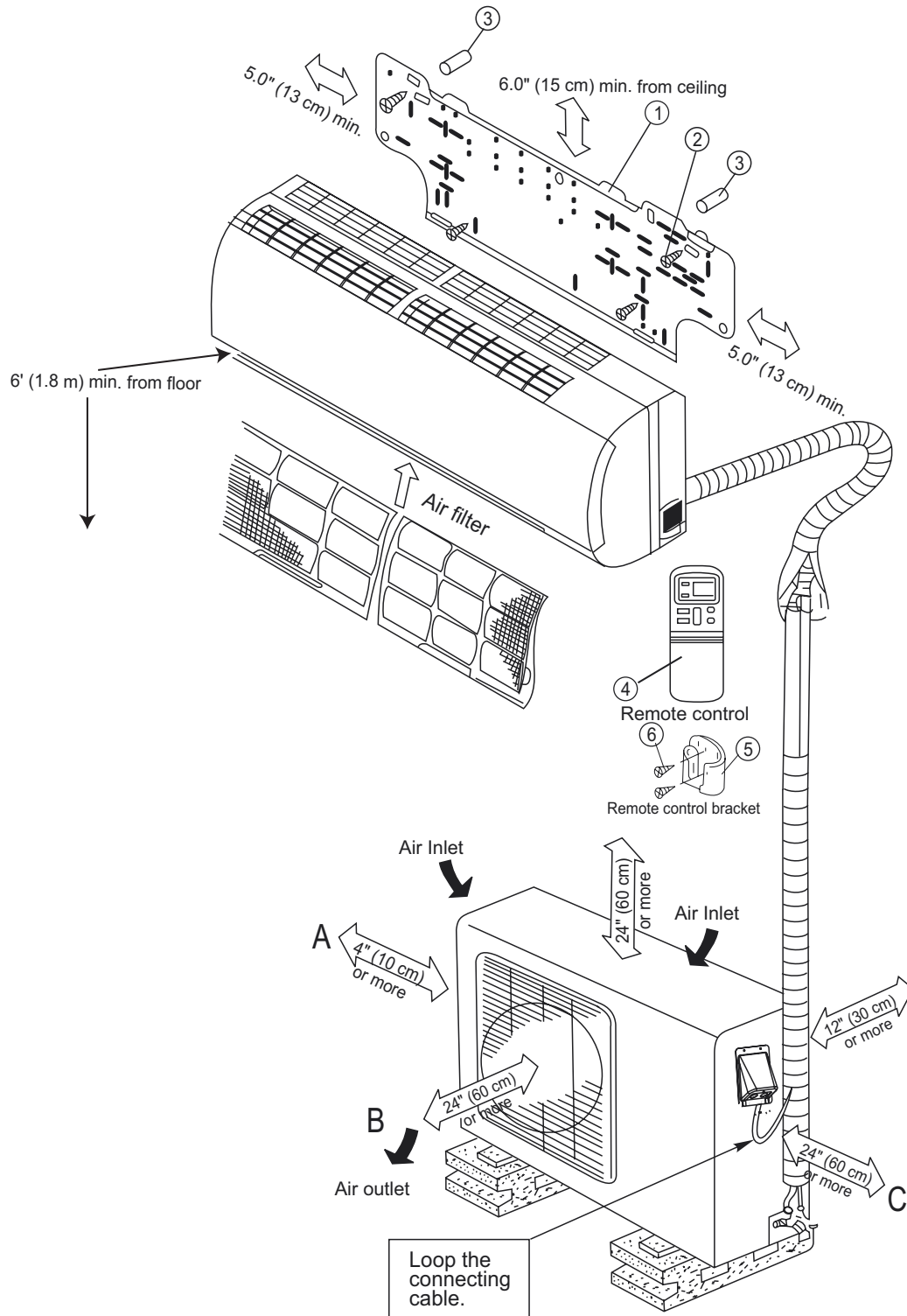
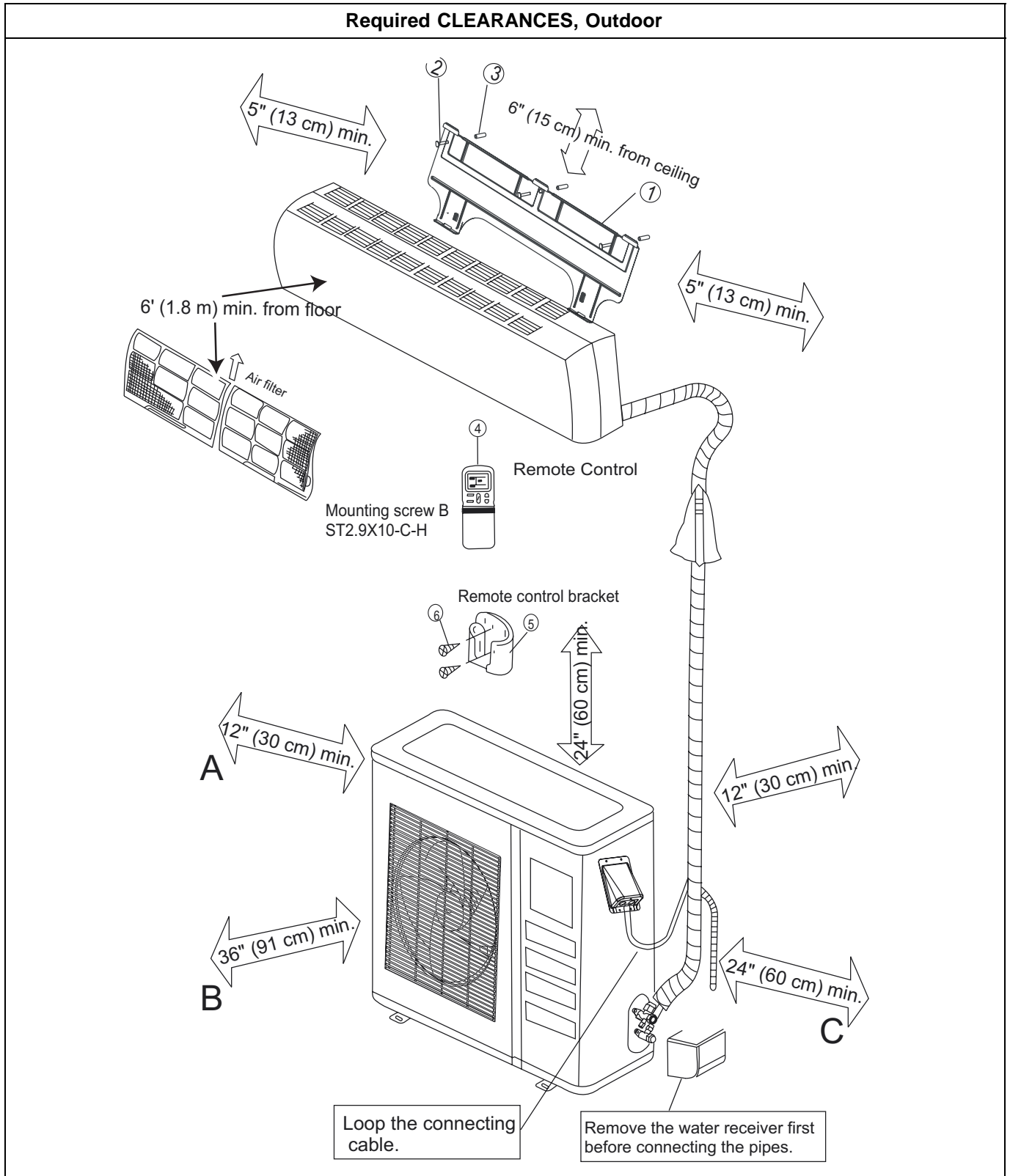

Fig. 1 – DFF4(A/H)H/DFC4(A/H)3 09–12
Parts List and Clearances

Note:

- If the outdoor unit is higher than the indoor unit, prevent rain from flowing into the indoor unit along the connection pipe by making a downward arc in the connection pipe before it enters the wall to the indoor unit. This will ensure that rain will drip from the connection pipe before it enters the wall.
- The illustration above is only a sketch. Different models may be slightly different.



**Fig. 2 – DFF4(A/H)H/DFC4(A/H)3 18–24
Parts List and Clearances**

Note:

- If the outdoor unit is higher than the indoor unit, prevent rain from flowing into the indoor unit along the connection pipe by making a downward arc in the connection pipe before it enters the wall to the indoor unit. This will ensure that rain will drip from the connection pipe before it enters the wall.
- The illustration above is only a sketch. Different models may be slightly different.

DIMENSIONS

INDOOR

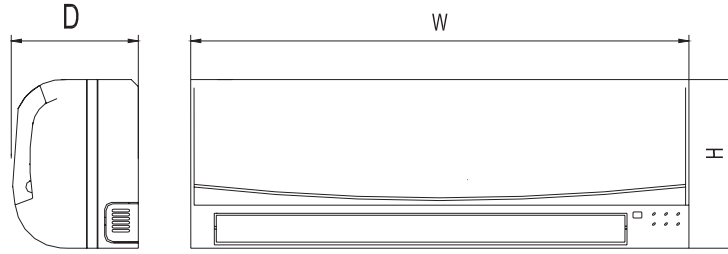

Model Size	W in. (mm)	H in. (mm)	D in. (mm)	Weight lb (kg)
09	32.09 (815)	11.02 (280)	7.68 (195)	17.6 (8)
12	35.67 (906)	11.26 (286)	9.25 (235)	25.3 (11.5)
18	49.21 (1250)	12.80 (325)	9.06 (230)	39.6 (18)
24	49.21 (1250)	12.80 (325)	9.06 (230)	39.6 (18)

OUTDOOR

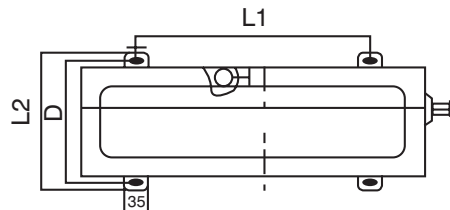
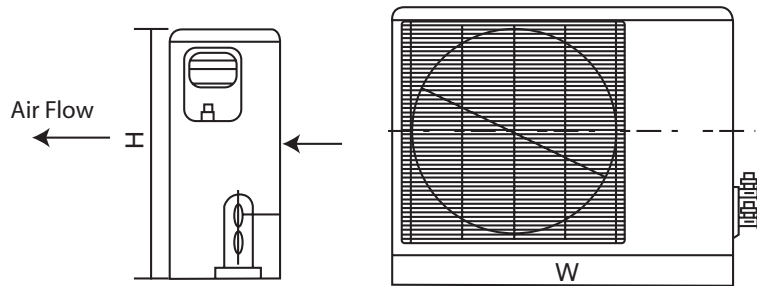

Model Size	W in. (mm)	H in. (mm)	D in. (mm)	L1 in. (mm)	L2 in. (mm)	Weight lb (kg) Cooling Only	Weight lb (kg) Heat Pumps
09	30.71 (780)	21.26 (540)	10.87 (276)	21.61 (549)	11.81 (300)	70.4 (32)	72.6 (33)
12	29.92 (760)	23.23 (590)	11.42 (290)	20.87 (530)	12.40 (315)	79.2 (36)	83.6 (38)
18	33.07 (840)	27.36 (695)	13.19 (335)	22.05 (560)	14.17 (360)	116.6 (53)	117.7 (53.5)
24	31.16 (893)	33.86 (860)	13.11 (333)	23.11 (588)	13.98 (355)	149.6 (68)	151 (68.5)

SERVICE VALVE LOCATIONS

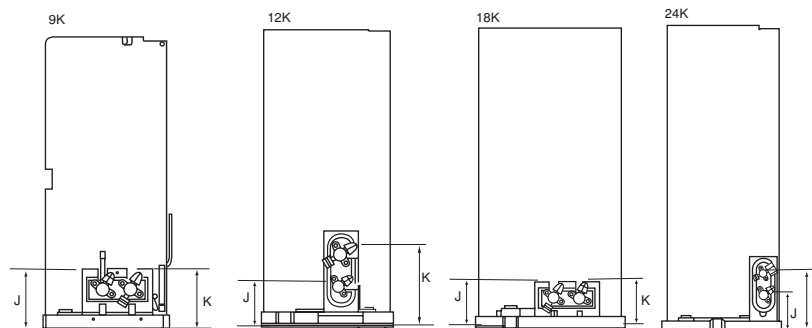

Service Valve Locations	9K in. (mm)	12K in. (mm)	18K in. (mm)	24K in. (mm)
J	3.46 (88)	3.19 (81)	3.46 (88)	4.02 (102)
K	3.46 (88)	5.63 (143)	3.62 (92)	6.57 (167)

Outdoor/Indoor Model Size	09J1B	12J1B	18K1B	24K1A
PHYSICAL DATA – Air Conditioner				
Cooling Capacity (BTU/hr)	9,200	11,400	17,500	22,000
SEER	13.0	13.0	13.0	13.0
Moisture Removal Gallons/hr (Liters/hr)	.24 (0.9)	.36 (1.35)	.41 (1.55)	.53 (2.0)
Indoor Fan CFM (High speed)	325	425	630	750
Indoor Sound Rating (dBA High – dBA Low)	53 – 39	58 – 51	59 – 54	64 – 59
Outdoor Sound Rating (dBA)	65	65	68	67
Liquid Line Connection Size (in.)	1/4	1/4	1/4	3/8
Vapor Line Connection Size (in.)	3/8	1/2	1/2	5/8
Maximum Vertical Separation (ft.) Indoor Higher than Outdoor	35	35	50	60
Maximum Vertical Separation (ft.) Indoor Lower than Outdoor	35	35	50	60
Maximum Line-set Length (ft.)	65	65	100	100
Factory Charge R-410A (lbs.)†	2.3	2.9	4.1	5.3
† Models 09, 12, and 18 are factory charged for 25 feet of interconnecting line. For greater line lengths (out to the limits specified in the literature) charge should be added at 0.1 oz. per each additional foot of line added.				
Net Weight, Outdoor Lbs. (Kg)	70.4 (32)	79.2 (36)	116.6 (53)	149.6 (68)
Net Weight, Indoor Lbs. (Kg)	17.6 (8)	25.3 (11.5)	39.6 (18)	39.6 (18)
OUTDOOR ELECTRICAL DATA – Air Conditioner				
Required Supply Voltage	115–1–60 AC		208/230–1–60 AC	
Minimum Circuit Ampacity – MCA (amps)	12	15	11	14
Maximum OverCurrent Protective device – MOCP (amps)	20	25	20	25
Compressor RLA (Rated Load Amps) LRA (Locked Rotor Amps)	7.5 40	9.9 47	7.3 32.6	9.7 34.8
Fan Motor Amps	0.69	0.69	0.78	0.62
INDOOR ELECTRICAL DATA – Air Conditioner				
Required Supply Voltage	35 DC		208/230–1–60 AC	
FLA (Full Load Amps)	1.1	1.18	0.26	0.39

Outdoor/Indoor Model Size	09J1B	12J1B	18K1B	24K1A
PHYSICAL DATA – Heat Pump				
Cooling Capacity (BTU/hr)	9,600	11,500	17,500	22,000
SEER	13.0	13.0	13.0	13.0
Heating Capacity (BTU/hr)	9,400	11,500	17,000	21,400
HSPF	7.7	7.7	7.7	7.7
Moisture Removal Gallons/hr (Liters/hr)	.24 (0.9)	.36 (1.35)	.41 (1.55)	.53 (2.0)
Indoor Fan CFM (High speed)	325	425	630	750
Indoor Sound Rating (dBA High – dBA Low)	52 – 42	59 – 51	54 – 58	55–60
Outdoor Sound Rating (dBA)	66	64	72	67
Liquid Line Connection Size (in.)	1/4	1/4	1/4	3/8
Vapor Line Connection Size (in.)	3/8	1/2	1/2	5/8
Maximum Vertical Separation (ft.) Indoor Higher than Outdoor	35	35	50	60
Maximum Vertical Separation (ft.) Indoor Lower than Outdoor	35	35	50	60
Maximum Line–set Length (ft.)	65	65	100	100
Factory Charge R–410A (lbs.)†	2.4	3.0	4.5	5.3
† Models 09 and 12 are factory charged for 25 feet of interconnecting line. For greater line lengths (out to the limits specified in the literature) charge should be added at 0.1 oz. per each additional foot of line added.				
Net Weight, Outdoor Lbs. (Kg)	72.6 (33)	83.6 (38)	117.7 (53.5)	151 (68.5)
Net Weight, Indoor Lbs. (Kg)	17.6 (8)	25.3 (11.5)	39.6 (18)	39.6 (18)
OUTDOOR ELECTRICAL DATA – Heat Pump				
Required Supply Voltage	115–1–60 AC		208/230–1–60 AC	
Minimum Circuit Ampacity – MCA (amps)	12	15	11	14
Maximum OverCurrent Protective device – MOCP (amps)	20	25	20	25
Compressor RLA (Rated Load Amps) LRA (Locked Rotor Amps)	7.5 40	9.9 47	7.3 32.6	9.7 34.8
Fan Motor Amps	0.69	0.69	0.78	0.62
INDOOR ELECTRICAL DATA – Heat Pump				
Required Supply Voltage	35 DC		208/230–1–60 AC	
FLA (Full Load Amps)	1.1	1.18	0.26	0.39

ACCESSORIES		
Part Number	Description	Used On Model Size
NADA001DK	Condensate Pump	9, 12
NADA002DK	Condensate Pump	18, 24
NADA002LA	Low Ambient Kit *	ALL
NADA004CH	Crankcase Heater (120V)	9, 12
NADA003CH	Crankcase Heater (240V)	18, 24
1173540	Isolation Relay (120V) *	9, 12
1174662	Isolation Relay (240V) *	18, 24

* When Low Ambient Kit is used with Heat Pump, additional Isolation Relay is required.

DUCT FREE SPLIT SYSTEM MODEL NUMBER IDENTIFICATION GUIDE – OUTDOOR

	DFC	4	A	3	09	J	1	B
DFC = Duct Free Condenser								
DFS = Duct Free System								
4 = Environmentally Sound R-410A		REFRIGERANT						
A = Air Conditioner								
H = Heat Pump				TYPE				
3 = 13								
4 = 14				NAMEPLATE SEER				
09 = 9,000 BTUH = ¾ ton								
12 = 12,000 BTUH = 1 ton								
18 = 18,000 BTUH = 1½ tons								
24 = 24,000 BTUH = 2 tons				NOMINAL CAPACITY				
J = 115-1-60								
K = 208/230-1-60						SUPPLY VOLTAGE		
1 = Single Zone								
2 = Dual Zone								
3 = Tri Zone								
Sales Code						SALES CODE / FEATURES		

DUCT FREE SPLIT SYSTEM MODEL NUMBER IDENTIFICATION GUIDE – INDOOR

	DFF	4	A	H	09	J	1	B
DFF = Duct Free Fan Coil								
DFS = Duct Free System								
4 = Environmentally Sound R-410A		REFRIGERANT						
A = Air Conditioner								
H = Heat Pump				TYPE				
H = High Wall								
U= Under Ceiling								
C = Cassette				APPLICATION				
09 = 9,000 BTUH = ¾ ton								
12 = 12,000 BTUH = 1 ton								
18 = 18,000 BTUH = 1½ tons								
24 = 24,000 BTUH = 2 tons				NOMINAL CAPACITY				
J = 115-1-60								
K = 208/230-1-60						SUPPLY VOLTAGE		
1 = Single Zone								
2 = Dual Zone								
3 = Tri Zone								
Sales Code						SALES CODE / FEATURES		