

HEAT CONTROLLER, INC.

Installation, Operation & Maintenance Manual

Commercial Horizontal & Vertical Packaged Water-Source Heat Pumps: HBH/V Compact

TABLE OF CONTENTS

Model Nomenclature	2	Electrical - Power & Low Voltage Wiring	22-24
General Information.....	3-4	Electrical - Thermostat Wiring	25
Physical Data.....	5	CXM Controls	26
Horizontal Installation	6-7,9	CXM Control - Safety Features	27-28
Field Conversion of Air Discharge	8	Unit Starting & Operating Conditions.....	29
Vertical Installation.....	10-11	Piping System Cleaning & Flushing	30
Piping Installation	12	Unit & System Checkout.....	31
Water Loop Applications.....	13	Unit Start-Up Procedure	32-33
Open Loop - Ground Water Systems	14-17	Unit Operating Procedures & Temperatures.....	34-37
Water Quality Standards	18	Preventive Maintenance	38
Electrical - Line Voltage.....	19	Functional Troubleshooting	39-42
Electrical Data	20-21		

HBH & HBV COMPACT Horizontal & Vertical HFC-410a Units

Entering Water Temperature Range: 20 - 120°F (-6.7 - 48.9°C)

Horizontal Water Source Heat Pump
 Sizes 006-060

Vertical Water Source Heat Pump
 Sizes 006-060

HBH & HBV Model Structure

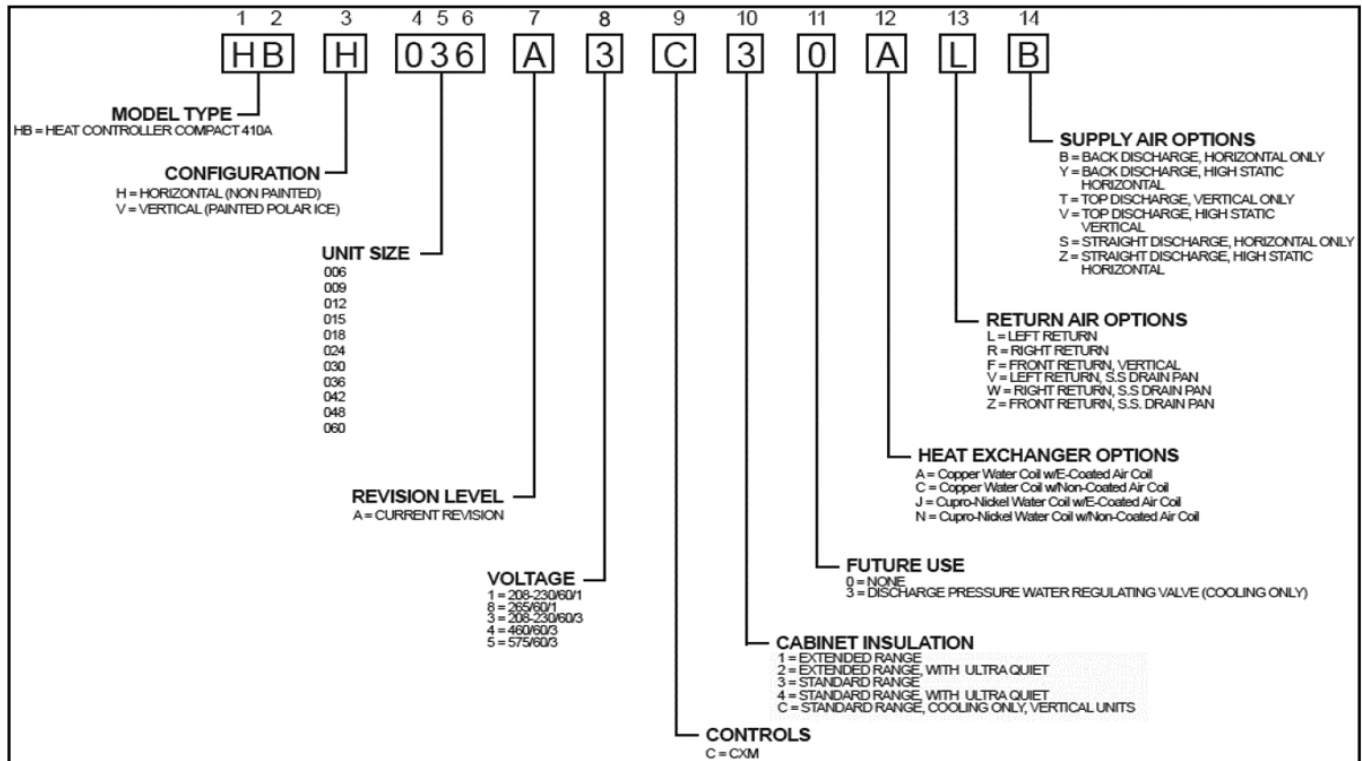

Basic Unit Description:

The basic unit price includes sealed heat pump refrigerant circuit and air handler within cabinetry, filter, and a factory installed hanger kit on horizontal units.

- **Cabinetry** – Compact design - galvanized steel construction - controls access panel - compressor access panels - FPT water connections - high and low voltage knockouts - 1" (25mm), air filter and filter rack. All vertical units have a left or right return air option, sizes 006-030 have a front return option. All horizontal units have field convertible discharge air patterns with extra parts required.
- **Standard Controls** - CXM Controller, loss of charge switch, high pressure switch, water coil low temperature cutout, lockout safety circuit resettable at thermostat or disconnect, LED fault indication, five minute anti-short cycle protection, random start, high and low voltage protection, condensate overflow protection, dry contact for alarm.
- **Compressor** - High efficiency hermetic scroll or rotary, overload protected - internally sprung & externally isolated using dual vibration dampening system for extra quiet operation. Mounting system incorporates rubber grommet isolation under the compressor and rubber grommet isolation between the compressor mounting tray and unit base.
- **Reversing Valve** - 4-way, pilot operated, solenoid activated in the cool mode.
- **Refrigerant Circuit** - Utilizes expansion valve metering device - copper tubing interconnecting all components - sealed & tested non-ozone depleting, R-410A refrigerant circuit with high & low side schraeder ports.
- **Water to Refrigerant Coil** - Tube-in-tube, convoluted copper inner water tube.
- **Refrigerant to Air Coil** - Lanced aluminum fins on rifled copper tubes.
- **Blower Motor** - Three-speed PSC direct drive, permanently lubricated (Two-speed on 575 volt applications).
- **UltraQuiet Option** - Compressor incorporates spring mounting system, 015-060 include compressor discharge muffler, blower housing is covered with high density noise suppression material.
- **Application** - Units can be applied in WLHP, GWHP, or GLHP applications.

General Information

Safety

Warnings, cautions and notices appear throughout this manual. Read these items carefully before attempting any installation, service or troubleshooting of the equipment.

DANGER: Indicates an immediate hazardous situation, which if not avoided will result in death or serious injury. DANGER labels on unit access panels must be observed.

WARNING: Indicates a potentially hazardous situation, which if not avoided could result in death or serious injury.

CAUTION: Indicates a potentially hazardous situation or an unsafe practice, which if not avoided could result in minor or moderate injury or product or property damage.

NOTICE: Notification of installation, operation or maintenance information, which is important, but which is not hazard-related.

WARNING!

WARNING! The Refrigerant Application and Service Manual should be read and understood before attempting to service refrigerant circuits with R-410A.

WARNING!

WARNING! To avoid the release of refrigerant into the atmosphere, the refrigerant circuit of this unit must be serviced only by technicians who meet local, state, and federal proficiency requirements.

CAUTION!

CAUTION! To avoid equipment damage, DO NOT use these units as a source of heating or cooling during the construction process. The mechanical components and filters will quickly become clogged with construction dirt and debris, which may cause system damage.

WARNING!

WARNING! All refrigerant discharged from this unit must be recovered WITHOUT EXCEPTION. Technicians must follow industry accepted guidelines and all local, state, and federal statutes for the recovery and disposal of refrigerants. If a compressor is removed from this unit, refrigerant circuit oil will remain in the compressor. To avoid leakage of compressor oil, refrigerant lines of the compressor must be sealed after it is removed.

Inspection

Upon receipt of the equipment, carefully check the shipment against the bill of lading. Make sure all units have been received. Inspect the packaging of each unit, and inspect each unit for damage. Insure that the carrier makes proper notation of any shortages or damage on all copies of the freight bill and completes a common carrier inspection report. Concealed damage not discovered during unloading must be reported to the carrier within 15 days of receipt of shipment. If not filed within 15 days, the freight company can deny the claim without recourse. Note: It is the responsibility of the purchaser to file all necessary claims with the carrier. Notify your equipment supplier of all damage within fifteen (15) days of shipment.

Storage

Equipment should be stored in its original packaging in a clean, dry area. Store units in an upright position at all times. Stack units a maximum of 3 units high.

Unit Protection

Cover units on the job site with either the original packaging or an equivalent protective covering. Cap the open ends of pipes stored on the job site. In areas where painting, plastering, and/or spraying has not been completed, all due precautions must be taken to avoid physical damage to the units and contamination by foreign material. Physical damage and contamination may prevent proper start-up and may result in costly equipment clean-up.

Examine all pipes, fittings, and valves before installing any of the system components. Remove any dirt or debris found in or on these components.

Pre-Installation

Installation, Operation, and Maintenance instructions are provided with each unit. Horizontal equipment is designed for installation above false ceiling or in a ceiling plenum. Other unit configurations are typically installed in a mechanical room. The installation site chosen should include adequate service clearance around the unit. Before unit start-up, read all manuals and become familiar with the unit and its operation. Thoroughly check the system before operation.

General Information**Prepare units for installation as follows:**

1. Compare the electrical data on the unit nameplate with ordering and shipping information to verify that the correct unit has been shipped.
2. Keep the cabinet covered with the original packaging until installation is complete and all plastering, painting, etc. is finished.
3. Verify refrigerant tubing is free of kinks or dents and that it does not touch other unit components.
4. Inspect all electrical connections. Connections must be clean and tight at the terminals.
5. Remove any blower support packaging (water-to-air units only).
6. Loosen compressor bolts on units equipped with compressor spring vibration isolation until the compressor rides freely on the springs. Remove shipping restraints.
7. Some airflow patterns are field convertible (horizontal units only). Locate the airflow conversion section of this IOM.
8. Locate and verify any hot water generator (HWG), hanger, or other accessory kit located in the compressor section or blower section.

CAUTION!

CAUTION! All three phase scroll compressors must have direction of rotation verified at start-up. Verification is achieved by checking compressor Amp draw. Amp draw will be substantially lower compared to nameplate values. Additionally, reverse rotation results in an elevated sound level compared to correct rotation. Reverse rotation will result in compressor internal overload trip within several minutes. Verify compressor type before proceeding.

CAUTION!

CAUTION! DO NOT store or install units in corrosive environments or in locations subject to temperature or humidity extremes (e.g., attics, garages, rooftops, etc.). Corrosive conditions and high temperature or humidity can significantly reduce performance, reliability, and service life. Always move and store units in an upright position. Tilting units on their sides may cause equipment damage.

CAUTION!

CAUTION! CUT HAZARD - Failure to follow this caution may result in personal injury. Sheet metal parts may have sharp edges or burrs. Use care and wear appropriate protective clothing, safety glasses and gloves when handling parts and servicing heat pumps.

NOTICE! Failure to remove shipping brackets from spring-mounted compressors will cause excessive noise, and could cause component failure due to added vibration.

Unit Physical Data

HBH/V Series

HB Series	006	009	012	015	018	024	030	036	042	048	060
Compressor (1 Each)	Rotary					Scroll					
Factory Charge R410A (oz)	17	18.5	23	32	43	43	47	50	70	74	82
PSC Fan Motor & Blower											
Fan Motor Type/Speeds	PSC/3	PSC/3	PSC-3	PSC/3	PSC/3	PSC/3	PSC/3	PSC/3	PSC/3	PSC/3	PSC/3
Fan Motor (hp)	1/25	1/10	1/10	1/6	1/6	1/4	3/4	1/2	3/4	3/4	1
Blower Wheel Size (Dia x w)	5x5	5x5	6x5	8x7	8x7	9x7	9x7	9x8	9x8	10x10	11x10
Water Connection Size											
IPT	1/2"	1/2"	1/2"	1/2"	1/2"	3/4"	3/4"	3/4"	3/4"	1"	1"
Vertical											
Air Coil Dimensions (H x W)	10x15	10x15	10x15	20x17.25	20x17.25	20x17.25	20x17.25	24x21.75	24x21.76	24x28.25	24x28.25
Filter Standard - 1" Throwaway	10x18	10x18	10x18	20x20	20x20	20x20	20x20	24x24	24x24	1-14x24, 1-18x24	1-14x24, 1-18x24
Weight - Operating (lbs.)	103	105	114	153	158	189	197	203	218	263	278
Weight - Packaged (lbs.)	113	115	124	158	163	194	202	209	224	270	285
Horizontal											
Air Coil Dimensions (H x W)	10x15	10x15	10x15	16x22	16x22	16x22	16x22	20x25	20x25	20x35	20x35
Filter Standard - 1"	10x18	10x18	10x18	16x25	16x25	18x25	18x25	20x28 or 2-20x14	20x28 or 2-20x14	1-20x24, 1-20x14	1-20x24, 1-20x14
Weight - Operating (lbs.)	103	105	114	153	158	174	182	203	218	263	278
Weight - Packaged (lbs.)	113	115	124	158	163	179	187	209	224	270	285

Notes:

Models 006-012 have spring compressor mounts, all others have grommets, TXV expansion device, and 1/2" & 3/4" electrical knockouts.

Unit Maximum Water Working Pressure	
Options	Max Pressure PSIG [kPa]
Base Unit	500 [3,445]
Discharge Pressure Water Regulating Valve	140 [965]

Use the lowest maximum pressure rating when multiple options are combined.

Horizontal Installation

Horizontal Unit Location

Units are not designed for outdoor installation. Locate the unit in an INDOOR area that allows enough space for service personnel to perform typical maintenance or repairs without removing unit from the ceiling. Horizontal units are typically installed above a false ceiling or in a ceiling plenum. Never install units in areas subject to freezing or where humidity levels could cause cabinet condensation (such as unconditioned spaces subject to 100% outside air). Consideration should be given to access for easy removal of the filter and access panels. Provide sufficient room to make water, electrical, and duct connection(s).

If the unit is located in a confined space, such as a closet, provisions must be made for return air to freely enter the space by means of a louvered door, etc. Any access panel screws that would be difficult to remove after the unit is installed should be removed prior to setting the unit. Refer to Figure 3 for an illustration of a typical installation. Refer to unit engineering design guide for dimensional data.

In limited side access installations, pre-removal of the control box side mounting screws will allow control box removal for future servicing (HB units only).

Conform to the following guidelines when selecting unit location:

1. Provide a hinged access door in concealed-spline or plaster ceilings. Provide removable ceiling tiles in T-bar or lay-in ceilings. Refer to horizontal unit dimensions for specific series and model in unit submittal data. Size the access opening to accommodate the service technician during the removal or replacement of the compressor and the removal or installation of the unit itself.
2. Provide access to hanger brackets, water valves and fittings. Provide screwdriver clearance to access panels, discharge collars and all electrical connections.
3. DO NOT obstruct the space beneath the unit with piping, electrical cables and other items that prohibit future removal of components or the unit itself.
4. Use a manual portable jack/lift to lift and support the weight of the unit during installation and servicing.

The installation of water source heat pump units and all associated components, parts and accessories which make up the installation shall be in accordance with the regulations of ALL authorities having jurisdiction and MUST conform to all applicable codes. It is the responsibility of the installing contractor to determine and comply with ALL applicable codes and regulations.

Mounting Horizontal Units

Horizontal units have hanger kits pre-installed from the factory as shown in Figure 1. Figure 3 shows a typical horizontal unit installation.

Horizontal heat pumps are typically suspended above a ceiling or within a soffit using field supplied, threaded rods sized to support the weight of the unit.

Use four (4) field supplied threaded rods and factory provided vibration isolators to suspend the unit. Hang the unit clear of the floor slab above and support the unit by the mounting bracket assemblies only. DO NOT attach the unit flush with the floor slab above.

Pitch the unit toward the drain as shown in Figure 2 to improve the condensate drainage. On small units (less than 2.5 tons/8.8kW) ensure that unit pitch does not cause condensate leaks inside the cabinet.

Figure 1: Hanger Bracket

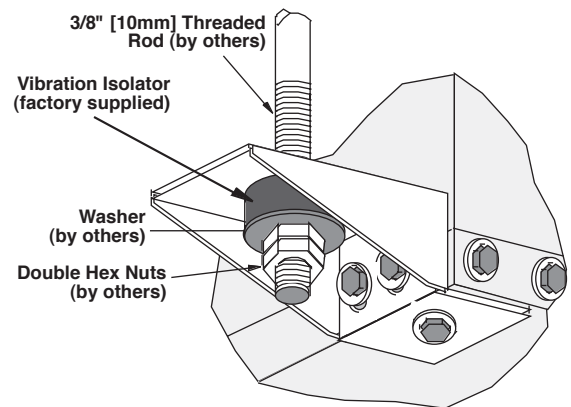
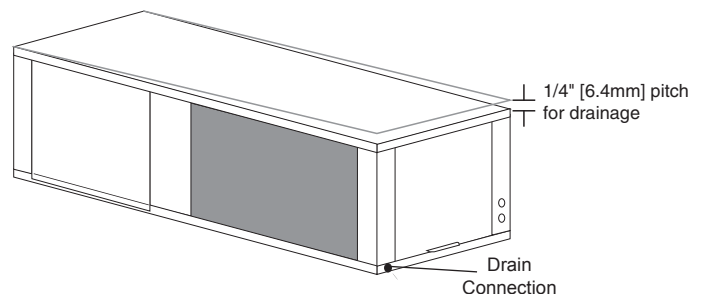
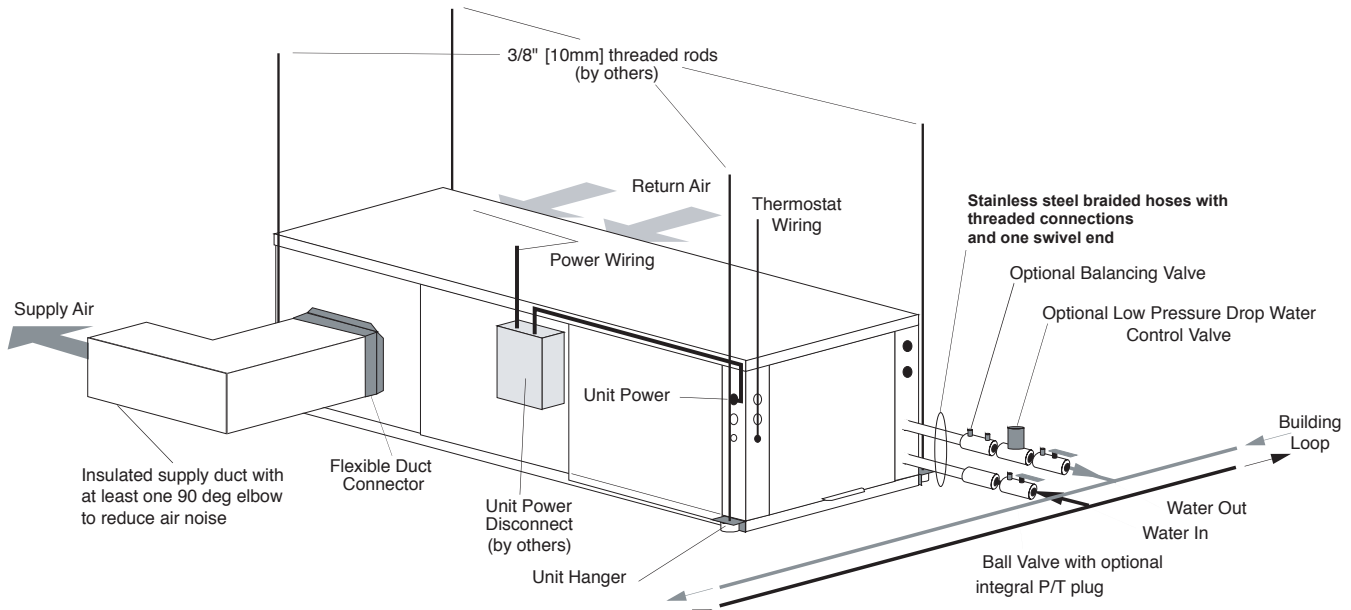

Figure 2: Horizontal Unit Pitch



Horizontal Installation

Figure 3: Typical Horizontal Unit Installation



Air Coil

To obtain maximum performance, the air coil should be cleaned before start-up. A 10% solution of dishwasher detergent and water is recommended for both sides of the coil. A thorough water rinse should follow. **UV based anti-bacterial systems may damage e-coated air coils.**

NOTICE! Installation Note - Ducted Return: Many horizontal WSHPs are installed in a return air ceiling plenum application (above ceiling). Vertical WSHPs are commonly installed in a mechanical room with free return (e.g. louvered door). Therefore, filter rails are the industry standard and are included on Heat Controller, Inc., commercial heat pumps for the purposes of holding the filter only. For ducted return applications, the filter rail must be removed and replaced with a duct flange or filter rack. Canvas or flexible connectors should also be used to minimize vibration between the unit and ductwork.

Field Conversion of Air Discharge

Overview

Horizontal units can be field converted between side (straight) and back (end) discharge using the instructions below.

Note: It is not possible to field convert return air between left or right return models due to the necessity of refrigeration copper piping changes.

Preparation

It is best to field convert the unit on the ground before hanging. If the unit is already hung it should be taken down for the field conversion.

Side to Back Discharge Conversion

1. Place unit in well lit area. Remove the screws as shown in Figure 4 to free top panel and discharge panel.
2. Lift out the access panel and set aside. Lift and rotate the discharge panel to the other position as shown, being careful with the blower wiring.
3. Check blower wire routing and connections for tension or contact with sheet metal edges. Reroute if necessary.
4. Check refrigerant tubing for contact with other components.
5. Reinstall top panel and screws noting that the location for some screws will have changed.
6. Manually spin the fan wheel to insure that the wheel is not rubbing or obstructed.
7. Replace access panels.

Back to Side Discharge Conversion

If the discharge is changed from back to side, use above instruction noting that illustrations will be reversed.

Left vs. Right Return

It is not possible to field convert return air between left or right return models due to the necessity of refrigeration copper piping changes. However, the conversion process of side to back or back to side discharge for either right or left return configuration is the same. In some cases, it may be possible to rotate the entire unit 180 degrees if the return air connection needs to be on the opposite side. Note that rotating the unit will move the piping to the other end of the unit.

Figure 4: Left Return Side to Back

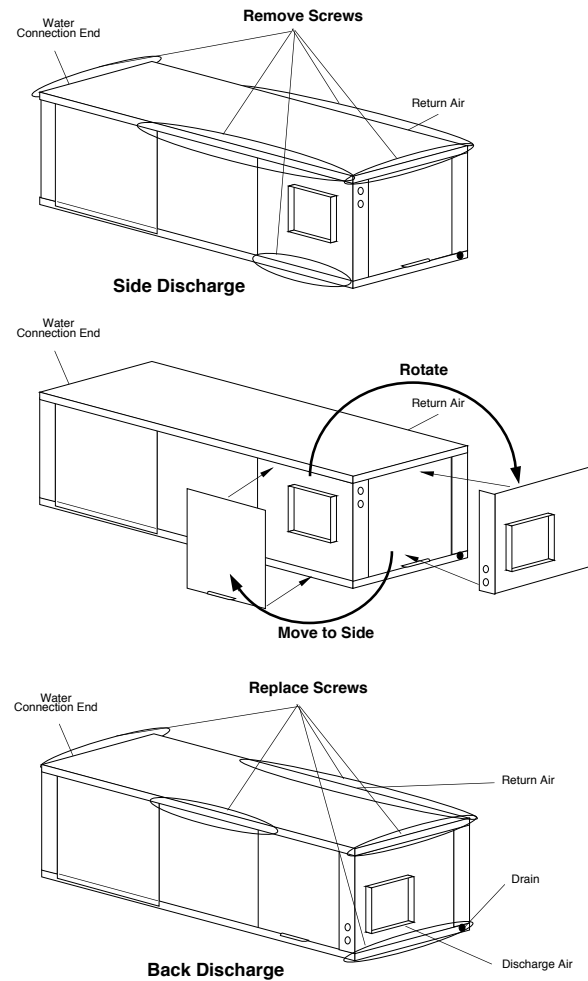
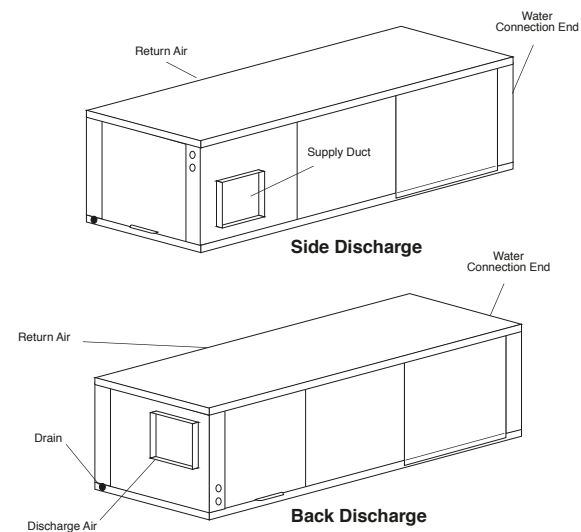

Figure 5: Right Return Side to Back



Horizontal Installation

Condensate Piping – Horizontal Units

Pitch the unit toward the drain as shown in Figure 2 to improve the condensate drainage. On small units (less than 2.5 tons/8.8 kW), insure that unit pitch does not cause condensate leaks inside the cabinet.

Install condensate trap at each unit with the top of the trap positioned below the unit condensate drain connection as shown in Figure 6.

Each unit must be installed with its own individual trap and connection to the condensate line (main) or riser. Provide a means to flush or blow out the condensate line. DO NOT install units with a common trap and/or vent.

Always vent the condensate line when dirt or air can collect in the line or a long horizontal drain line is required. Also vent when large units are working against higher external static pressure than other units connected to the same condensate main since this may cause poor drainage for all units on the line. WHEN A VENT IS INSTALLED IN THE DRAIN LINE, IT MUST BE LOCATED AFTER THE TRAP IN THE DIRECTION OF THE CONDENSATE FLOW.

Figure 6: Horizontal Condensate Connection

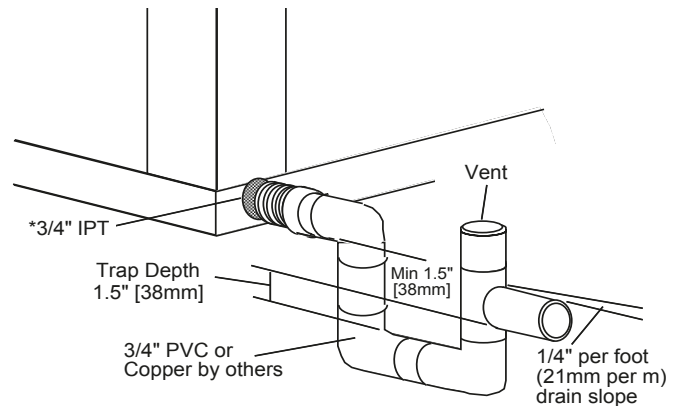

* Some units include a painted drain connection. Using a threaded pipe or similar device to clear any excess paint accumulated inside this fitting may ease final drain line installation.

Rev.: 6/26/09S

CAUTION!

CAUTION! Ensure condensate line is pitched toward drain 1/4" per foot [21mm per m] of run.

DUCT SYSTEM INSTALLATION

Duct System Installation

Proper duct sizing and design is critical to the performance of the unit. The duct system should be designed to allow adequate and even airflow through the unit during operation. Air flow through the unit MUST be at or above the minimum stated airflow for the unit to avoid equipment damage. Duct systems should be designed for quiet operation. Refer to Figure 3 for horizontal duct system details or figure 8 for vertical duct system details. A flexible connector is recommended for both discharge and return air duct connections on metal duct systems to eliminate the transfer of vibration to the duct system. To maximize sound attenuation of the unit blower, the supply and return plenums should include internal fiberglass duct liner or be constructed from ductboard for the first few feet. Application of the unit to uninsulated ductwork in an unconditioned space

is not recommended, as the unit's performance will be adversely affected.

At least one 90° elbow should be included in the supply duct to reduce air noise. If air noise or excessive air flow is a problem, the blower speed can be changed. For airflow charts, consult submittal data for the series and model of the specific unit.

If the unit is connected to existing ductwork, a previous check should have been made to insure that the ductwork has the capacity to handle the airflow required for the unit. If ducting is too small, as in the replacement of a heating only system, larger ductwork should be installed. All existing ductwork should be checked for leaks and repaired as necessary.

Vertical Installation

Vertical Unit Location

Units are not designed for outdoor installation. Locate the unit in an INDOOR area that allows enough space for service personnel to perform typical maintenance or repairs without removing unit from the mechanical room/closet. Vertical units are typically installed in a mechanical room or closet. Never install units in areas subject to freezing or where humidity levels could cause cabinet condensation (such as unconditioned spaces subject to 100% outside air). Consideration should be given to access for easy removal of the filter and access panels. Provide sufficient room to make water, electrical, and duct connection(s).

If the unit is located in a confined space, such as a closet, provisions must be made for return air to freely enter the space by means of a louvered door, etc. Any access panel screws that would be difficult to remove after the unit is installed should be removed prior to setting the unit. Refer to Figures 7 and 8 for typical installation illustrations. Refer to unit submittal data or engineering design guide for dimensional data.

1. Install the unit on a piece of rubber, neoprene or other mounting pad material for sound isolation. The pad should be at least 3/8" [10mm] to 1/2" [13mm] in thickness. Extend the pad beyond all four edges of the unit.
2. Provide adequate clearance for filter replacement and drain pan cleaning. Do not block filter access with piping, conduit or other materials. Refer to unit submittal data or engineering design guide for dimensional data.
3. Provide access for fan and fan motor maintenance and for servicing the compressor and coils without removing the unit.
4. Provide an unobstructed path to the unit within the closet or mechanical room. Space should be sufficient to allow removal of the unit, if necessary.
5. In limited side access installations, pre-removal of the control box side mounting screws will allow control box removal for future servicing (HB units only).
6. Provide access to water valves and fittings and screwdriver access to the unit side panels, discharge collar and all electrical connections.

Figure 7: Vertical Unit Mounting

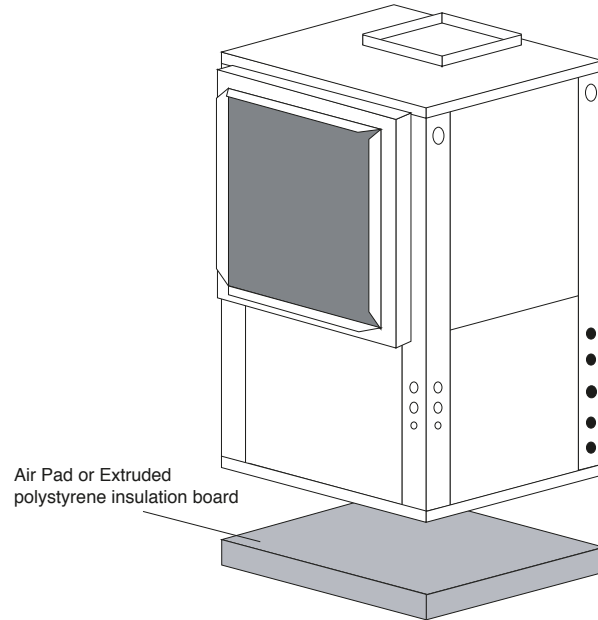
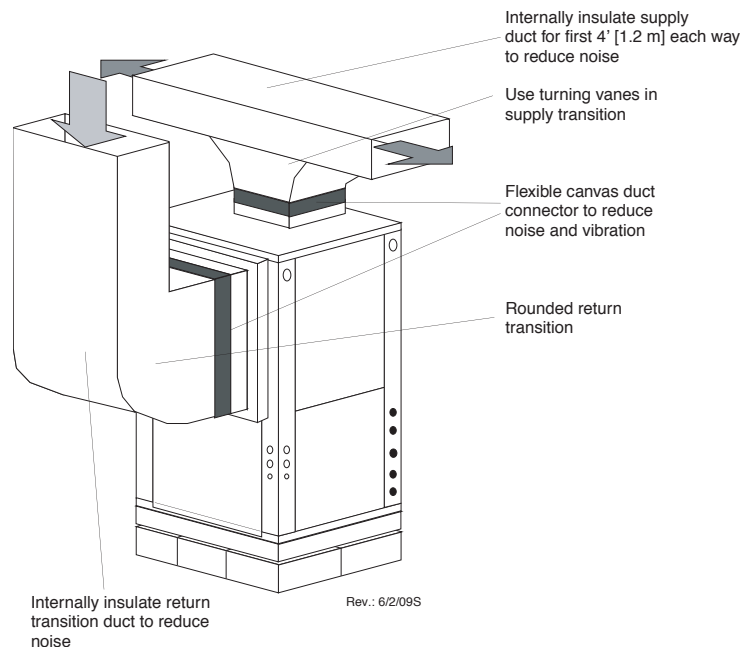

Figure 8: Typical Vertical Unit Installation Using Ducted Return Air



Vertical Installation

Sound Attenuation for Vertical Units

Sound attenuation is achieved by enclosing the unit within a small mechanical room or a closet. Additional measures for sound control include the following:

1. Mount the unit so that the return air inlet is 90° to the return air grille. Refer to Figure 9. Install a sound baffle as illustrated to reduce line-of sight sound transmitted through return air grilles.
2. Mount the unit on a rubber or neoprene isolation pad to minimize vibration transmission to the building structure.

Figure 9: Vertical Sound Attenuation

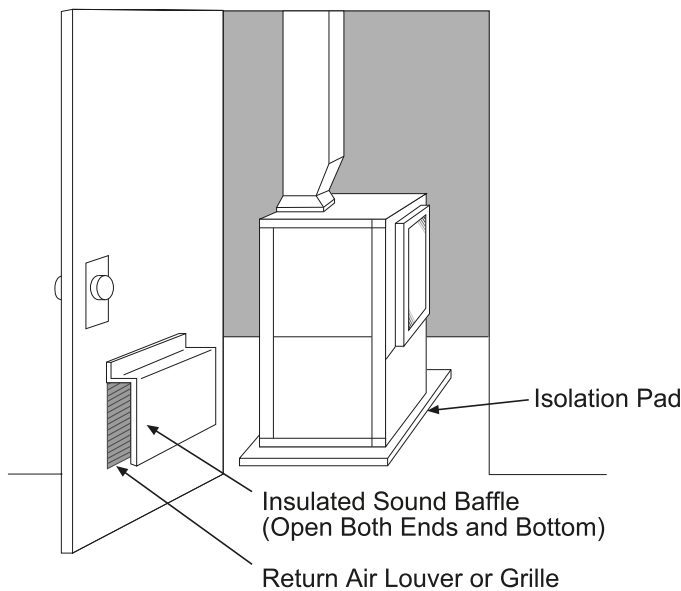

NOTICE! Units with clear plastic drain lines should have regular maintenance (as required) to avoid buildup of debris, especially in new construction.

Condensate Piping – Vertical Units

Vertical units utilize a condensate hose inside the cabinet as a trapping loop; therefore an external trap is not necessary. Figure 10a shows typical condensate connections. Figure 10b illustrates the internal trap for a typical vertical heat pump. Each unit must be installed with its own individual vent (where necessary) and a means to flush or blow out the condensate drain line. Do not install units with a common trap and/or vent.

Figure 10a: Vertical Condensate Drain

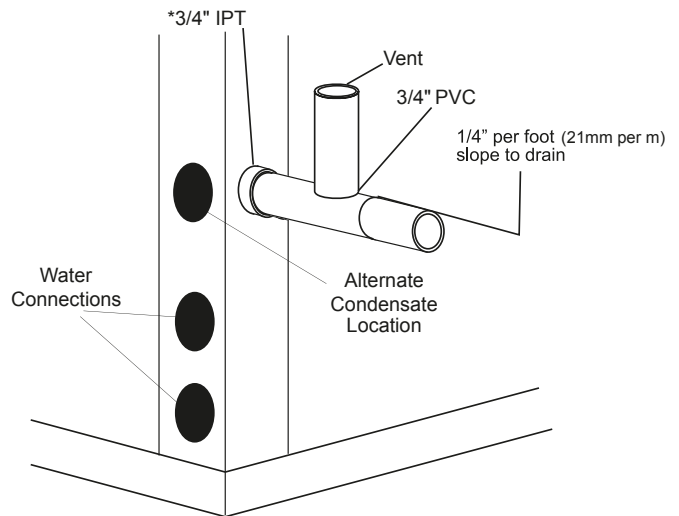

* Some units include a painted drain connection. Using a threaded pipe or similar device to clear any excess paint accumulated inside this fitting may ease final drain line installation.

Figure 10b: Vertical Internal Condensate Trap

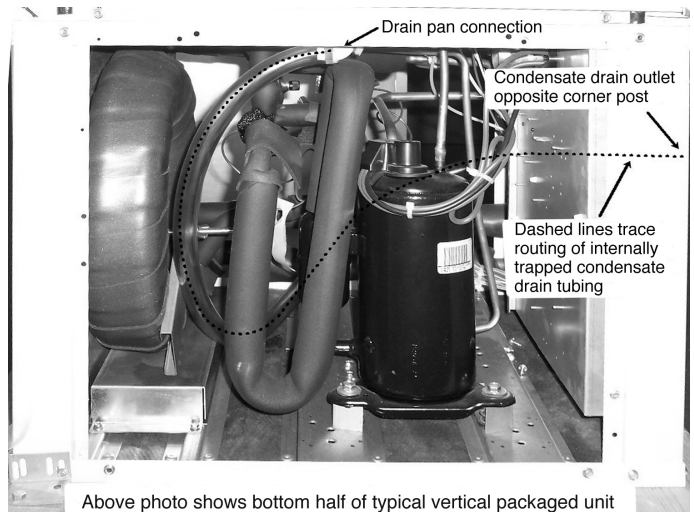

Piping Installation

Installation of Supply and Return Piping

Follow these piping guidelines.

1. Install a drain valve at the base of each supply and return riser to facilitate system flushing.
2. Install shut-off / balancing valves and unions at each unit to permit unit removal for servicing.
3. Place strainers at the inlet of each system circulating pump.
4. Select the proper hose length to allow slack between connection points. Hoses may vary in length by +2% to -4% under pressure.
5. Refer to Table 1. Do not exceed the minimum bend radius for the hose selected. Exceeding the minimum bend radius may cause the hose to collapse, which reduces water flow rate. Install an angle adapter to avoid sharp bends in the hose when the radius falls below the required minimum.

Insulation is not required on loop water piping except where the piping runs through unheated areas, outside the building or when the loop water temperature is below the minimum expected dew point of the pipe ambient conditions. Insulation is required if loop water temperature drops below the dew point (insulation is required for ground loop applications in most climates).

Pipe joint compound is not necessary when Teflon® thread tape is pre-applied to hose assemblies or when flared-end connections are used. If pipe joint compound is preferred, use compound only in small amounts on the external pipe threads of the fitting adapters. Prevent sealant from reaching the flared surfaces of the joint.

Note: When anti-freeze is used in the loop, insure that it is compatible with the Teflon tape or pipe joint compound that is applied.

Maximum allowable torque for brass fittings is 30 ft-lbs [41 N-m]. If a torque wrench is not available, tighten finger-tight plus one quarter turn. Tighten steel fittings as necessary.

Optional pressure-rated hose assemblies designed specifically for use with Heat Controller units are available. Similar hoses can be obtained from alternate suppliers. Supply and return hoses are fitted with swivel-joint fittings at one end to prevent kinking during installation.

Refer to Figure 11 for an illustration of a typical supply/return hose kit. Adapters secure hose assemblies to the unit and risers. Install hose assemblies properly and check regularly to avoid system failure and reduced service life.

A backup wrench is required when tightening water connections on HB series to prevent water line damage.

CAUTION!

CAUTION! Corrosive system water requires corrosion resistant fittings and hoses, and may require water treatment.

CAUTION!

CAUTION! Do not bend or kink supply lines or hoses.

CAUTION!

CAUTION! Piping must comply with all applicable codes.

Table 1: Metal Hose Minimum Bend Radii

Hose Diameter	Minimum Bend Radii
1/2" [12.7mm]	2-1/2" [6.4cm]
3/4" [19.1mm]	4" [10.2cm]
1" [25.4mm]	5-1/2" [14cm]
1-1/4" [31.8mm]	6-3/4" [17.1cm]

NOTICE! Do not allow hoses to rest against structural building components. Compressor vibration may be transmitted through the hoses to the structure, causing unnecessary noise complaints.

Figure 11: Supply/Return Hose Kit

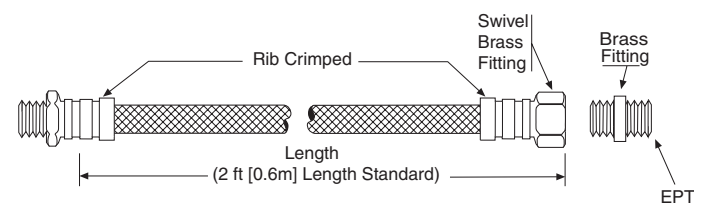

Water-Loop Heat Pump Applications

Commercial Water Loop Applications

Commercial systems typically include a number of units connected to a common piping system. Any unit plumbing maintenance work can introduce air into the piping system; therefore air elimination equipment is a major portion of the mechanical room plumbing. In piping systems expected to utilize water temperatures below 60°F [16°C], 1/2" (13mm) closed cell insulation is required on all piping surfaces to eliminate condensation (extended range units required). Metal to plastic threaded joints should never be used due to their tendency to leak over time. A backup wrench must be used for HB series equipment fittings.

Teflon tape thread sealant is recommended to minimize internal fouling of the heat exchanger. Do not over tighten connections and route piping so as not to interfere with service or maintenance access. Hose kits are available from Heat Controller in different configurations as shown in Figure 12 for connection between the unit and the piping system.

The piping system should be flushed to remove dirt, piping chips, and other foreign material prior to operation (see "Piping System Cleaning and Flushing Procedures" in this manual). The flow rate is usually set between 2.25 and 3.5 gpm per ton [2.9 and 4.5 l/m per kW] of cooling capacity. Heat Controller recommends 3 gpm per ton [3.9 l/m per kW] for most applications of water loop heat pumps. To insure proper maintenance and servicing, P/T ports are imperative for temperature and flow verification, as well as performance checks.

Water loop heat pump (cooling tower/boiler) systems typically utilize a common loop, maintained between 60 - 90°F [16 - 32°C]. The use of a closed circuit evaporative cooling tower with a secondary heat exchanger between the tower and the water loop is recommended. If an open type cooling tower is used continuously, chemical treatment and filtering will be necessary.

Figure 12: Typical Water-Loop Application

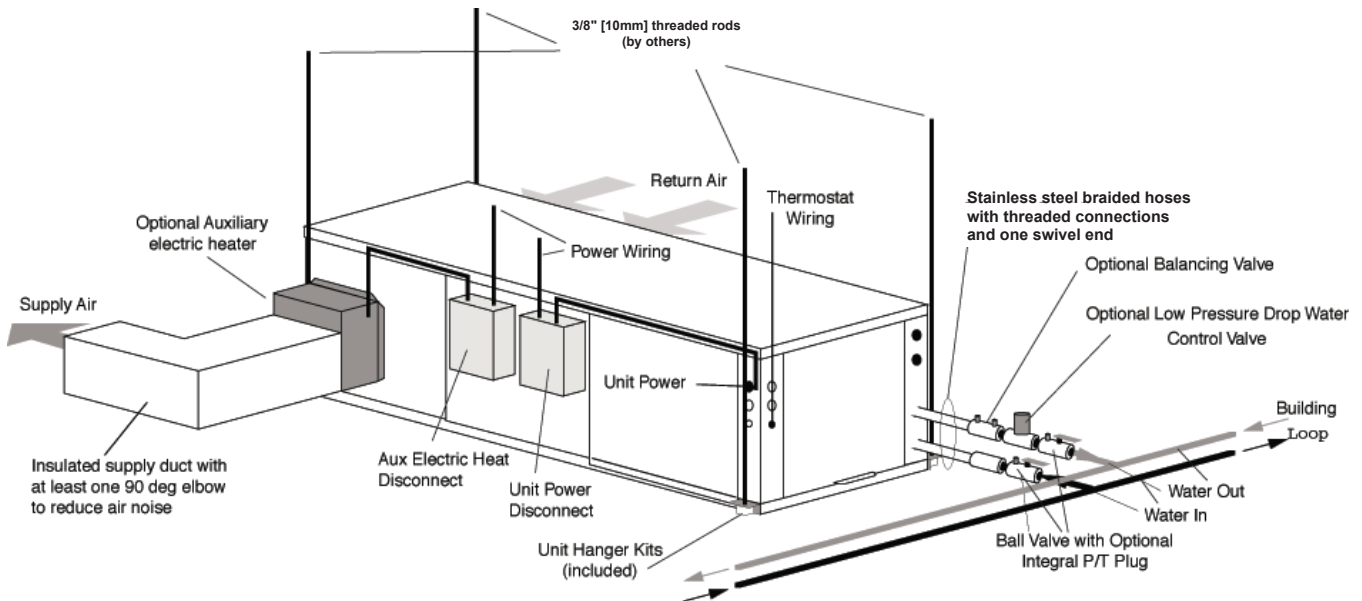

Low Water Temperature Cutout Setting - CXM Control

When antifreeze is selected, the FP1 jumper (JW3) should be clipped to select the low temperature (antifreeze 13°F [-10.6°C]) set point and avoid nuisance faults (see "Low Water Temperature Cutout Selection" in this manual). NOTE: Low water temperature operation requires extended range equipment.

Ground-Loop Heat Pump Applications

CAUTION!

CAUTION! The following instructions represent industry accepted installation practices for closed loop earth coupled heat pump systems. Instructions are provided to assist the contractor in installing trouble free ground loops. These instructions are recommendations only. State/provincial and local codes **MUST** be followed and installation **MUST** conform to ALL applicable codes. It is the responsibility of the installing contractor to determine and comply with ALL applicable codes and regulations.

CAUTION!

CAUTION! Ground loop applications require extended range equipment and optional refrigerant/water circuit insulation.

Pre-Installation

Prior to installation, locate and mark all existing underground utilities, piping, etc. Install loops for new construction before sidewalks, patios, driveways, and other construction has begun. During construction, accurately mark all ground loop piping on the plot plan as an aid in avoiding potential future damage to the installation.

Piping Installation

The typical closed loop ground source system is shown in Figure 13. All earth loop piping materials should be limited to polyethylene fusion only for in-ground sections of the loop. Galvanized or steel fittings should not be used at any time due to their tendency to corrode. All plastic to metal threaded fittings should be avoided due to their potential to leak in earth coupled applications. A flanged fitting should be substituted. P/T plugs should be used so that flow can be measured using the pressure drop of the unit heat exchanger.

Earth loop temperatures can range between 25 and 110°F [-4 to 43°C]. Flow rates between 2.25 and 3 gpm per ton [2.41 to 3.23 l/m per kW] of cooling capacity is recommended in these applications.

Test individual horizontal loop circuits before backfilling. Test vertical U-bends and pond loop assemblies prior to installation. Pressures of at least 100 psi [689 kPa] should be used when testing. Do not exceed the pipe pressure rating. Test entire system when all loops are assembled.

Flushing the Earth Loop

Upon completion of system installation and testing, flush the system to remove all foreign objects and purge to remove all air.

Antifreeze

In areas where minimum entering loop temperatures drop below 40°F [5°C] or where piping will be routed through areas subject to freezing, antifreeze is required. Alcohols and glycols are commonly used as antifreeze. Freeze protection should be maintained to 15°F [9°C] below the lowest expected entering loop temperature. For example, if 30°F [-1°C] is the minimum expected entering loop temperature, the leaving loop temperature would be 25 to 22°F [-4 to -6°C] and freeze protection should be at 15°F [-10°C]. Calculation is as follows:
 $30^{\circ}\text{F} - 15^{\circ}\text{F} = 15^{\circ}\text{F}$ $[-1^{\circ}\text{C} - 9^{\circ}\text{C} = -10^{\circ}\text{C}]$.

All alcohols should be premixed and pumped from a reservoir outside of the building when possible or introduced under the water level to prevent fumes. Calculate the total volume of fluid in the piping system. Then use the percentage by volume shown in table 2 for the amount of antifreeze needed. Antifreeze concentration should be checked from a well mixed sample using a hydrometer to measure specific gravity.

Low Water Temperature Cutout Setting - CXM Control

When antifreeze is selected, the FP1 jumper (JW3) should be clipped to select the low temperature (antifreeze 13°F [-10.6°C]) set point and avoid nuisance faults (see "Low Water Temperature Cutout Selection" in this manual). **NOTE:** Low water temperature operation requires extended range equipment.

Table 2: Antifreeze Percentages by Volume

Type	Minimum Temperature for Low Temperature Protection			
	10°F [-12.2°C]	15°F [-9.4°C]	20°F [-6.7°C]	25°F [-3.9°C]
Methanol	25%	21%	16%	10%
100% USP food grade Propylene Glycol	38%	25%	22%	15%
Ethanol*	29%	25%	20%	14%

* Must not be denatured with any petroleum based product

Ground-Loop Heat Pump Applications

Figure 13: Typical Ground-Loop Application

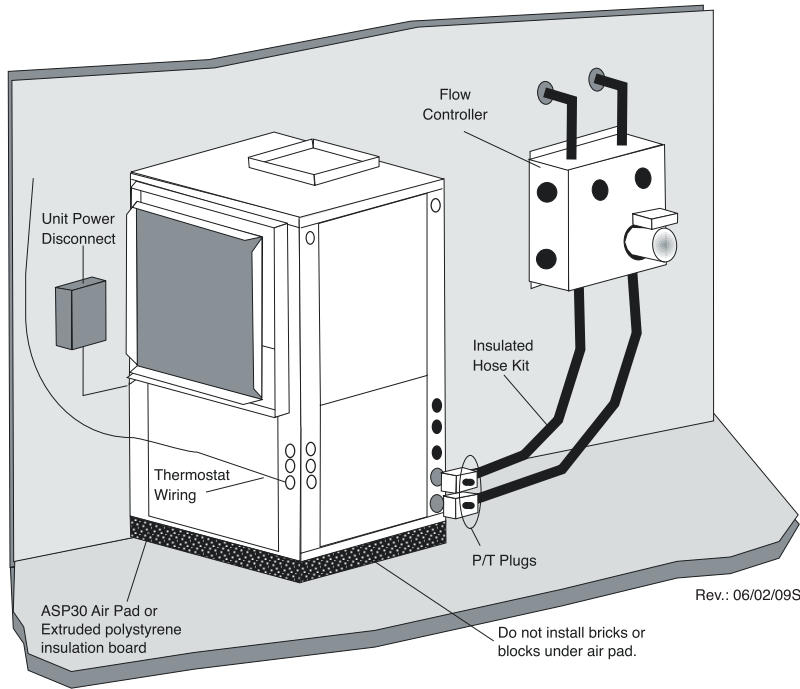

Ground-Water Heat Pump Applications

Open Loop - Ground Water Systems

Typical open loop piping is shown in Figure 14. Shut off valves should be included for ease of servicing. Boiler drains or other valves should be "tee'd" into the lines to allow acid flushing of the heat exchanger. Shut off valves should be positioned to allow flow through the coax via the boiler drains without allowing flow into the piping system. P/T plugs should be used so that pressure drop and temperature can be measured. Piping materials should be limited to copper or PVC SCH80. **Note: Due to the pressure and temperature extremes, PVC SCH40 is not recommended.**

Water quantity should be plentiful and of good quality. Consult table 3 for water quality guidelines. The unit can be ordered with either a copper or cupro-nickel water heat exchanger. Consult Table 3 for recommendations. Copper is recommended for closed loop systems and open loop ground water systems that are not high in mineral content or corrosiveness. In conditions anticipating heavy scale formation or in brackish water, a cupro-nickel heat exchanger is recommended. In ground water situations where scaling could be heavy or where biological growth such as iron bacteria will be present, an open loop system is not recommended. Heat exchanger coils may over time lose heat exchange capabilities due to build up of mineral deposits. Heat exchangers must only be serviced by a qualified technician, as acid and special pumping equipment is required. Desuperheater coils can likewise become scaled and possibly plugged. In areas with extremely hard water, the owner should be informed that the heat exchanger may require occasional acid flushing. In some cases, the desuperheater option should not be recommended due to hard water conditions and additional maintenance required.

Water Quality Standards

Table 3 should be consulted for water quality requirements. Scaling potential should be assessed using the pH/Calcium hardness method. If the pH <7.5 and the calcium hardness is less than 100 ppm, scaling potential is low. If this method yields numbers out of range of those listed, the Ryznar Stability and Langelier Saturation indices should be calculated. Use the appropriate scaling surface temperature for the application, 150°F [66°C] for direct use (well water/open loop) and DHW (desuperheater); 90°F [32°C] for indirect use. A monitoring plan should be implemented in these probable scaling situations. Other water quality issues such as iron fouling, corrosion prevention and erosion and clogging should be referenced in Table 3.

Expansion Tank and Pump

Use a closed, bladder-type expansion tank to minimize mineral formation due to air exposure. The expansion tank should be sized to provide at least one minute continuous run time of the pump using its drawdown capacity rating to prevent pump short cycling. Discharge water from the unit is not contaminated in any manner and can be disposed of in various ways, depending on local building codes (e.g. recharge well, storm sewer, drain field, adjacent stream or pond, etc.). Most local codes forbid the use of sanitary sewer for disposal. Consult your local building and zoning department to assure compliance in your area.

Water Control Valve

Note the placement of the water control valve in Figure 14. Always maintain water pressure in the heat exchanger by placing the water control valve(s) on the discharge line to prevent mineral precipitation during the off-cycle. Pilot operated slow closing valves are recommended to reduce water hammer. If water hammer persists, a mini-expansion tank can be mounted on the piping to help absorb the excess hammer shock. Insure that the total 'VA' draw of the valve can be supplied by the unit transformer. For instance, a slow closing valve can draw up to 35VA. This can overload smaller 40 or 50 VA transformers depending on the other controls in the circuit. A typical pilot operated solenoid valve draws approximately 15VA (see Figure 21). Note the special wiring diagrams for slow closing valves (Figures 22 & 23).

Flow Regulation

Flow regulation can be accomplished by two methods. One method of flow regulation involves simply adjusting the ball valve or water control valve on the discharge line. Measure the pressure drop through the unit heat exchanger, and determine flow rate from Tables 8a through 8e. Since the pressure is constantly varying, two pressure gauges may be needed. Adjust the valve until the desired flow of 1.5 to 2 gpm per ton [2.0 to 2.6 l/m per kW] is achieved. A second method of flow control requires a flow control device mounted on the outlet of the water control valve. The device is typically a brass fitting with an orifice of rubber or plastic material that is designed to allow a specified flow rate. On occasion, flow control devices may produce velocity noise that can be reduced by applying some back pressure from the ball valve located on the discharge line. Slightly closing the valve will spread the pressure drop over both devices, lessening the velocity noise. **NOTE: When EWT is below 50°F [10°C], 2 gpm per ton (2.6 l/m per kW) is required.**

Ground-Water Heat Pump Applications

Water Coil Low Temperature Limit Setting

For all open loop systems the 30°F [-1.1°C] FP1 setting (factory setting-water) should be used to avoid freeze damage to the unit. See "Low Water Temperature Cutout Selection" in this manual for details on the low limit setting.

Figure 14: Typical Open Loop/Well Application

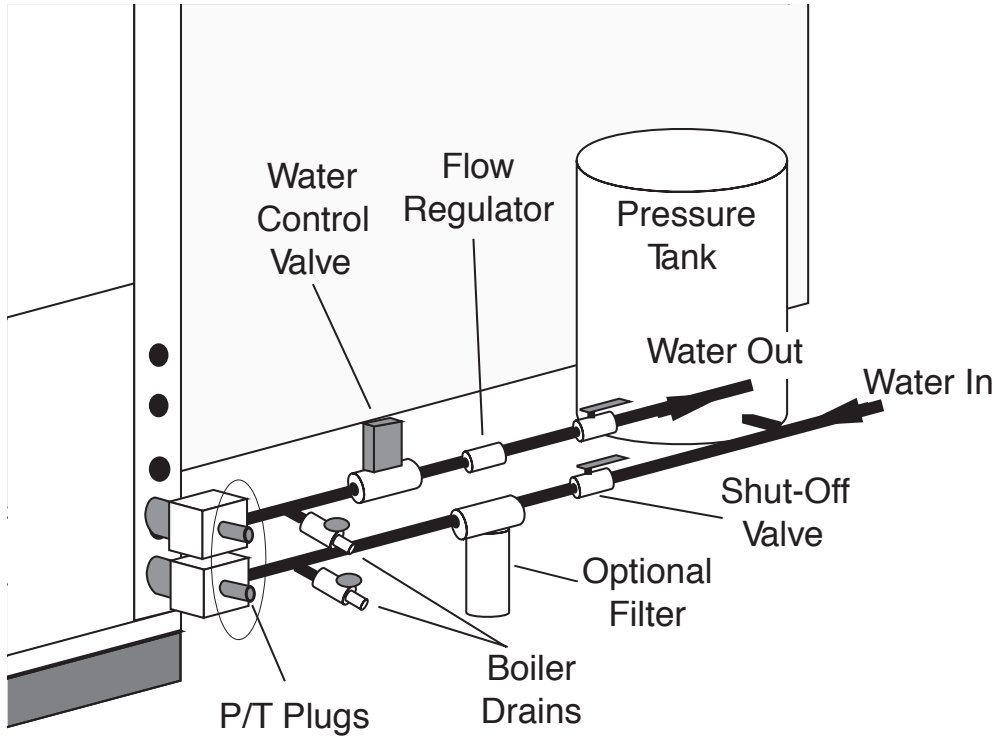

Water Quality Standards

Table 3: Water Quality Standards

Water Quality Parameter	HX Material	Closed Recirculating	Open Loop and Recirculating Well		
Scaling Potential - Primary Measurement					
Above the given limits, scaling is likely to occur. Scaling indexes should be calculated using the limits below					
pH/Calcium Hardness Method	All	-	pH < 7.5 and Ca Hardness <100ppm		
Index Limits for Probable Scaling Situations - (Operation outside these limits is not recommended)					
Scaling indexes should be calculated at 150°F [66°C] for direct use and HWG applications, and at 90°F [32°C] for indirect HX use. A monitoring plan should be implemented.					
Ryznar Stability Index	All	-	6.0 - 7.5 If >7.5 minimize steel pipe use.		
Langelier Saturation Index	All	-	-0.5 to +0.5 If <-0.5 minimize steel pipe use. Based upon 150°F [66°C] HWG and Direct well, 85°F [29°C] Indirect Well HX		
Iron Fouling					
Iron Fe ²⁺ (Ferrous) (Bacterial Iron potential)	All	-	<0.2 ppm (Ferrous) If Fe ²⁺ (ferrous)>0.2 ppm with pH 6 - 8, O ₂ <5 ppm check for iron bacteria		
Iron Fouling	All	-	<0.5 ppm of Oxygen Above this level deposition will occur.		
Corrosion Prevention					
pH	All	6 - 8.5 Monitor/treat as needed	6 - 8.5 Minimize steel pipe below 7 and no open tanks with pH <8		
Hydrogen Sulfide (H ₂ S)	All	-	<0.5 ppm At H ₂ S>0.2 ppm, avoid use of copper and copper nickel piping or HX's. Rotten egg smell appears at 0.5 ppm level. Copper alloy (bronze or brass) cast components are OK to <0.5 ppm.		
Ammonia ion as hydroxide, chloride, nitrate and sulfate compounds	All	-	<0.5 ppm		
Maximum Chloride Levels	Copper CuproNickel 304 SS 316 SS Titanium	- - - - -	Maximum Allowable at maximum water temperature.		
			50°F (10°C)	75°F (24°C)	100°F (38°C)
			<20ppm	NR	NR
			<150 ppm	NR	NR
			<400 ppm	<250 ppm	<150 ppm
			<1000 ppm	<550 ppm	< 375 ppm
>1000 ppm	>550 ppm	>375 ppm			
Erosion and Clogging					
Particulate Size and Erosion	All	<10 ppm of particles and a maximum velocity of 6 fps [1.8 m/s] Filtered for maximum 800 micron [800mm, 20 mesh] size.	<10 ppm (<1 ppm "sandfree" for reinjection) of particles and a maximum velocity of 6 fps [1.8 m/s]. Filtered for maximum 800 micron [800mm, 20 mesh] size. Any particulate that is not removed can potentially clog components.		

- Notes:
- Closed Recirculating system is identified by a closed pressurized piping system.
 - Recirculating open wells should observe the open recirculating design considerations.
 - NR - Application not recommended.
 - "-" No design Maximum.

Electrical - Line Voltage

Electrical - Line Voltage

All field installed wiring, including electrical ground, must comply with the National Electrical Code as well as all applicable local codes. Refer to the unit electrical data for fuse sizes. Consult wiring diagram for field connections that must be made by the installing (or electrical) contractor. All final electrical connections must be made with a length of flexible conduit to minimize vibration and sound transmission to the building.

General Line Voltage Wiring

Be sure the available power is the same voltage and phase shown on the unit serial plate. Line and low voltage wiring must be done in accordance with local codes or the National Electric Code, whichever is applicable.

Transformer

All 208/230 voltage units are factory wired for 208 volt. If supply voltage is 230 volt, installer must rewire transformer. See wire diagram for connections.

WARNING!

WARNING! To avoid possible injury or death due to electrical shock, open the power supply disconnect switch and secure it in an open position during installation.

CAUTION!

CAUTION! Use only copper conductors for field installed electrical wiring. Unit terminals are not designed to accept other types of conductors.

Electrical - Line Voltage

Table 4a: HB Series Electrical Data - (Standard 60Hz Units)

HB Model	Voltage Code	Rated Voltage	Voltage Min/Max	Compressor			Fan Motor FLA	Total Unit FLA	Min Circuit Amp	Max Fuse/HACR
				QTY	RLA	LRA				
006	1	208-230/60/1	197/254	1	3.3	17.7	0.40	3.7	4.5	15
009	1	208-230/60/1	197/254	1	5.6	22.2	0.80	6.4	7.8	15
012	1	208-230/60/1	197/254	1	5.1	32.5	0.80	5.9	7.2	15
015	1	208-230/60/1	197/254	1	6.0	29.0	1.00	7.0	8.5	15
	8	265/60/1	239/292	1	5.4	28.0	0.86	6.3	7.6	15
018	1	208-230/60/1	197/254	1	7.2	33.0	1.00	8.2	10.0	15
	8	265/60/1	239/292	1	5.9	28.0	0.86	6.8	8.2	15
024	1	208-230/60/1	197/254	1	12.8	58.3	1.50	14.3	17.5	30
	8	265/60/1	239/292	1	9.6	54.0	1.30	10.9	13.3	20
030	1	208-230/60/1	197/254	1	14.1	73.0	3.00	17.1	20.6	30
	8	265/60/1	239/292	1	11.2	60.0	2.70	13.9	16.7	25
	3	208-230/60/3	197/254	1	8.9	58.0	3.00	11.9	14.1	20
	4	460/60/3	414/506	1	4.2	28.0	1.70	5.9	7.0	15
036	1	208-230/60/1	197/254	1	16.7	79.0	1.80	18.5	22.7	35
	8	265/60/1	239/292	1	13.5	72.0	2.00	15.5	18.9	30
	3	208-230/60/3	197/254	1	10.4	73.0	1.80	12.2	14.8	25
	4	460/60/3	414/506	1	5.8	38.0	1.24	7.0	8.5	15
042	1	208-230/60/1	197/254	1	17.9	112.0	3.00	20.9	25.4	40
	3	208-230/60/3	197/254	1	13.5	88.0	3.00	16.5	19.9	30
	4	460/60/3	414/506	1	6.0	44.0	1.70	7.7	9.2	15
	5	575/60/3	518/633	1	4.9	34.0	1.40	6.3	7.5	15
048	1	208-230/60/1	197/254	1	21.8	117.0	3.40	25.2	30.7	50
	3	208-230/60/3	197/254	1	13.7	83.1	3.40	17.1	20.5	30
	4	460/60/3	414/506	1	6.2	41.0	1.80	8.0	9.6	15
	5	575/60/3	518/633	1	4.8	33.0	1.40	6.2	7.4	15
060	1	208-230/60/1	197/254	1	26.3	134.0	4.90	31.2	37.8	60
	3	208-230/60/3	197/254	1	15.6	110.0	4.90	20.5	24.4	40
	4	460/60/3	414/506	1	7.8	52.0	2.50	10.3	12.3	20
	5	575/60/3	518/633	1	5.8	38.9	1.90	7.7	9.2	15

HACR circuit breaker in USA only
All fuses Class RK-5

Table 4b: HB Series Electrical Data - (Standard 60Hz Units High Static)

HB Model	Voltage Code	Rated Voltage	Voltage Min/ Max	Compressor			Fan Motor FLA	Total Unit FLA	Min Circuit Amp	Max Fuse/ HACR
				QTY	RLA	LRA				
015	1	208-230/60/1	197/254	1	6.0	29.0	1.00	7.0	8.5	15
	8	265/60/1	239/292	1	5.4	28.0	0.86	6.3	7.6	15
018	1	208-230/60/1	197/254	1	7.2	33.0	1.50	8.7	10.5	15
	8	265/60/1	239/292	1	5.9	28.0	1.30	7.2	8.7	15
024	1	208-230/60/1	197/254	1	12.8	58.3	3.00	15.8	19.0	30
	8	265/60/1	239/292	1	9.6	54.0	2.70	12.3	14.7	20
030	1	208-230/60/1	197/254	1	14.1	73.0	3.00	17.1	20.6	30
	8	265/60/1	239/292	1	11.2	60.0	2.70	13.9	16.7	25
	3	208-230/60/3	197/254	1	8.9	58.0	3.00	11.9	14.1	20
	4	460/60/3	414/506	1	4.2	28.0	1.70	5.9	7.0	15
036	1	208-230/60/1	197/254	1	16.7	79.0	3.00	19.7	23.9	40
	8	265/60/1	239/292	1	13.5	72.0	2.70	16.2	19.6	30
	3	208-230/60/3	197/254	1	10.4	73.0	3.00	13.4	16.0	25
	4	460/60/3	414/506	1	5.8	38.0	1.70	7.5	9.0	15
042	1	208-230/60/1	197/254	1	17.9	112.0	3.00	20.9	25.4	40
	3	208-230/60/3	197/254	1	13.5	88.0	3.00	16.5	19.9	30
	4	460/60/3	414/506	1	6.0	44.0	1.70	7.7	9.2	15
	5	575/60/3	518/633	1	4.9	34.0	1.40	6.3	7.5	15
048	1	208-230/60/1	197/254	1	21.8	117.0	4.90	26.7	32.2	50
	3	208-230/60/3	197/254	1	13.7	83.1	4.90	18.6	22.0	35
	4	460/60/3	414/506	1	6.2	41.0	2.50	8.7	10.3	15
	5	575/60/3	518/633	1	4.8	33.0	1.90	6.7	7.9	15
060	1	208-230/60/1	197/254	1	26.3	134.0	5.80	32.1	38.7	60
	3	208-230/60/3	197/254	1	15.6	110.0	5.80	21.4	25.3	40
	4	460/60/3	414/506	1	7.8	52.0	2.60	10.4	12.4	20
	5	575/60/3	518/633	1	5.8	38.9	2.30	8.1	9.6	15

HACR circuit breaker in USA only
 All fuses Class RK-5

Electrical - Power Wiring

WARNING!

WARNING! Disconnect electrical power source to prevent injury or death from electrical shock.

CAUTION!

CAUTION! Use only copper conductors for field installed electrical wiring. Unit terminals are not designed to accept other types of conductors.

Power Connection

Line voltage connection is made by connecting the incoming line voltage wires to the "L" side of the contractor as shown in Figure 15. Consult electrical data tables for correct fuse size.

Transformer

All 208/230 voltage units are factory wired for 208 volt. If supply voltage is 230 volt, installer must rewire transformer. See wire diagram for connections.

Electrical - Line Voltage

All field installed wiring, including electrical ground, must comply with the National Electrical Code as well as all applicable local codes. Refer to the unit electrical data for fuse sizes. Consult wiring diagram for field connections that must be made by the installing (or electrical) contractor. All final electrical connections must be made with a length of flexible conduit to minimize vibration and sound transmission to the building.

General Line Voltage Wiring

Be sure the available power is the same voltage and phase shown on the unit serial plate. Line and low voltage wiring must be done in accordance with local codes or the National Electric Code, whichever is applicable.

Figure 15: HB Single Phase Line Voltage Field Wiring. Three phase wiring is similar except that all three power wires are directly connected to the contractor.

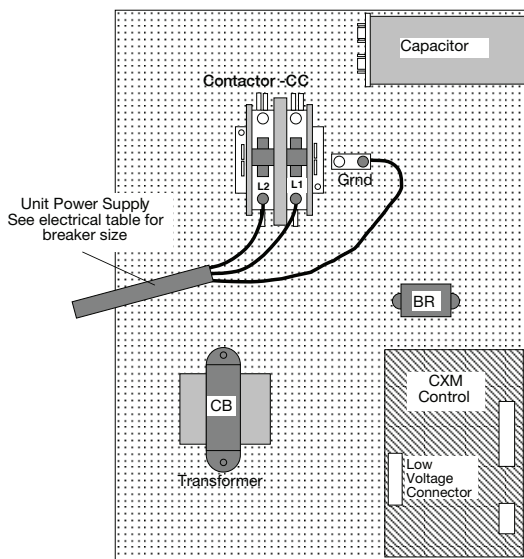

Rev.: 5/17/01 B

Electrical - Power & Low Voltage Wiring

Blower Speed Selection – Units with PSC Motor
 PSC (Permanent Split Capacitor) blower fan speed can be changed by moving the blue wire on the fan motor terminal block to the desired speed as shown in Figure 16. Most Heat Controller units are shipped on the medium speed tap. Consult submittal data or engineering design guide for specific unit airflow tables. Typical unit design delivers rated airflow at nominal static (0.15 in. w.g. [37Pa]) on medium speed and rated airflow at a higher static (0.4 to 0.5 in. w.g. [100 to 125 Pa]) on high speed for applications where higher static is required. Low speed will deliver approximately 85% of rated airflow at 0.10 in. w.g. [25 Pa]. An optional high static blower is available on some models.

Special Note for AHRI Testing: To achieve rated airflow for ARI testing purposes on all PSC products, it is necessary to change the fan speed to “HI” speed. When the heat pump has experienced less than 100 operational hours and the coil has not had sufficient time to be “seasoned”, it is necessary to clean the coil with a mild surfactant such as Calgon to remove the oils left by manufacturing processes and enable the condensate to properly “sheet” off of the coil.

Figure 16: PSC Motor Speed Selection

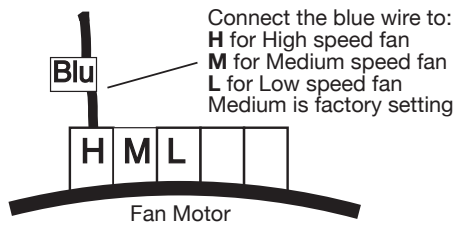

ELECTRICAL - LOW VOLTAGE WIRING

Thermostat Connections

The thermostat should be wired directly to the CXM board. Figure 17 shows wiring for HB units. See “Electrical – Thermostat” for specific terminal connections.

Low Water Temperature Cutout Selection

The CXM control allows the field selection of low water (or water-antifreeze solution) temperature limit by clipping jumper JW3, which changes the sensing temperature associated with thermistor FP1. Note that the FP1 thermistor is located on the refrigerant line between the coaxial heat exchanger and expansion device (TXV or cap tube). Therefore, FP1 is sensing refrigerant temperature, not water temperature, which is a better indication of how water flow rate/temperature is affecting the refrigeration circuit.

The factory setting for FP1 is for systems using water (30°F [-1.1°C] refrigerant temperature). In low water temperature (extended range) applications with antifreeze (most ground loops), jumper JW3 should be clipped as shown in Figure 18 to change the setting to 10°F [-12.2°C] refrigerant temperature, a more suitable temperature when using an antifreeze solution. All Heat Controller units operating with entering water temperatures below 59°F [15°C] must include the optional water/refrigerant circuit insulation package to prevent internal condensation.

Figure 17: HB Low Voltage Field Wiring

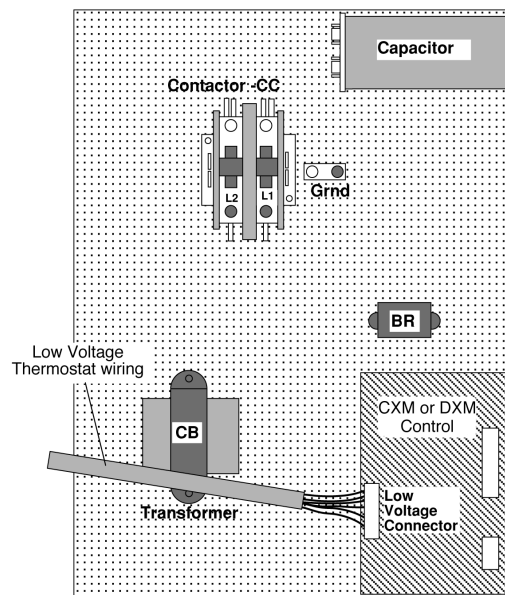

Electrical - Low Voltage Wiring

Figure 18: FP1 Limit Setting

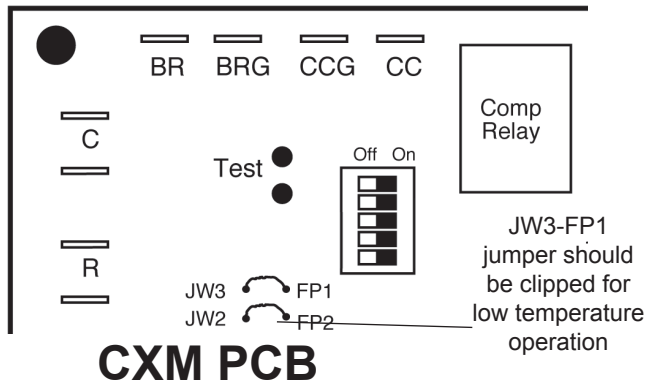
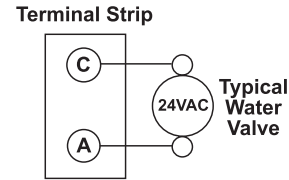

Figure 19: Accessory Wiring



Water Solenoid Valves

An external solenoid valve(s) should be used on ground water installations to shut off flow to the unit when the compressor is not operating. A slow closing valve may be required to help reduce water hammer. Figure 19 shows typical wiring for a 24VAC external solenoid valve. Figures 20 and 21 illustrate typical slow closing water control valve wiring for Taco 500 series and Taco ESP series valves. Slow closing valves take approximately 60 seconds to open (very little water will flow before 45 seconds). Once fully open, an end switch allows the compressor to be energized. Only relay or triac based electronic thermostats should be used with slow closing valves. When wired as shown, the slow closing valve will operate properly with the following notations:

1. The valve will remain open during a unit lockout.
2. The valve will draw approximately 25-35 VA through the "Y" signal of the thermostat.

Note: This valve can overheat the anticipator of an electromechanical thermostat. Therefore, only relay or triac based thermostats should be used.

Accessory Connections

A terminal paralleling the compressor contactor coil has been provided on the CXM control. Terminal "A" is designed to control accessory devices, such as water valves. Note: This terminal should be used only with 24 Volt signals and not line voltage. Terminal "A" is energized with the compressor contactor. See Figure 19 or the specific unit wiring diagram for details.

Low Voltage VA Ratings

Component	VA
Typical Blower Relay	6 - 7
Typical Reversing Valve Solenoid	4 - 6
30A Compressor Contactor	6 - 9
Subtotal	16 - 22
+ CXM board (5 - 9 VA)*	21 - 31
Remaining VA for Accessories	19 - 29

*Standard transformer for CXM board is 50VA.

CAUTION!

CAUTION! Many units are installed with a factory or field supplied manual or electric shut-off valve. DAMAGE WILL OCCUR if shut-off valve is closed during unit operation. A high pressure switch must be installed on the heat pump side of any field provided shut-off valves and connected to the heat pump controls in series with the built-in refrigerant circuit high pressure switch to disable compressor operation if water pressure exceeds pressure switch setting. The field installed high pressure switch shall have a cut-out pressure of 300 psig and a cut-in pressure of 250 psig.

Figure 20: Taco 500 Series Valve Wiring

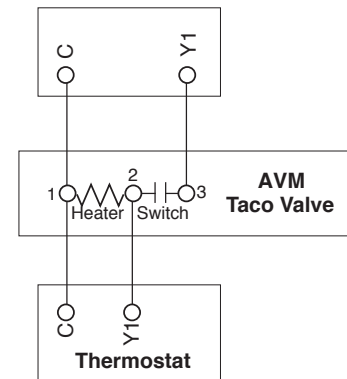
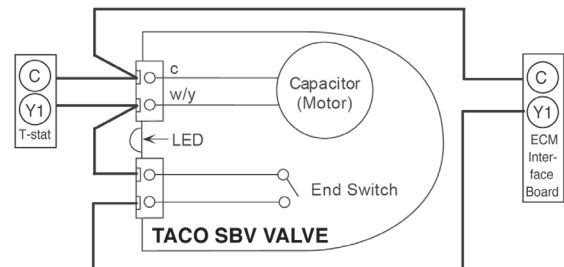

Figure 21: Taco SBV Valve Wiring



Electrical - Thermostat Wiring

Thermostat Installation

The thermostat should be located on an interior wall in a larger room, away from supply duct drafts. DO NOT locate the thermostat in areas subject to sunlight, drafts or on external walls. The wire access hole behind the thermostat may in certain cases need to be sealed to prevent erroneous temperature measurement. Position the thermostat back plate against the wall so that it appears level and so the thermostat wires protrude

through the middle of the back plate. Mark the position of the back plate mounting holes and drill holes with a 3/16" (5mm) bit. Install supplied anchors and secure plate to the wall. Thermostat wire must be 18 AWG wire. Wire the appropriate thermostat as shown in Figures 22 through 25c to the low voltage terminal strip on the CXM control board. Practically any heat pump thermostat will work with Heat Controller units, provided it has the correct number of heating and cooling stages.

Figure 22: Units With PSC Fan And CXM

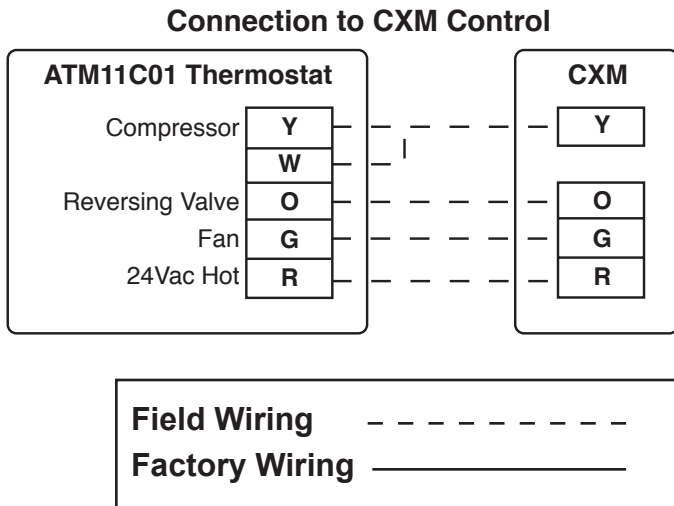

CXM Controls

CXM Control

For detailed control information, see CXM Application, Operation and Maintenance manual.

Field Selectable Inputs

Test mode: Test mode allows the service technician to check the operation of the control in a timely manner. By momentarily shorting the test terminals, the CXM control enters a 20 minute test mode period in which all time delays are sped up 15 times. Upon entering test mode, the status LED will flash a code representing the last fault. For diagnostic ease at the thermostat, the alarm relay will also cycle during test mode. The alarm relay will cycle on and off similar to the status LED to indicate a code representing the last fault, at the thermostat. Test mode can be exited by shorting the test terminals for 3 seconds.
Retry Mode: If the control is attempting a retry of a fault, the status LED will slow flash (slow flash = one flash every 2 seconds) to indicate the control is in the process of retrying.

Field Configuration Options

Note: In the following field configuration options, jumper wires should be clipped **ONLY** when power is removed from the CXM control.

Water coil low temperature limit setting: Jumper 3 (JW3-FP1 Low Temp) provides field selection of temperature limit setting for FP1 of 30°F or 10°F [-1°F or -12°C] (refrigerant temperature).

Not Clipped = 30°F [-1°C]. Clipped = 10°F [-12°C].

Air coil low temperature limit setting: Jumper 2 (JW2-FP2 Low Temp) provides field selection of temperature limit setting for FP2 of 30°F or 10°F [-1°F or -12°C] (refrigerant temperature). Note: This jumper should only be clipped under extenuating circumstances, as recommended by the factory.

Not Clipped = 30°F [-1°C]. Clipped = 10°F [-12°C].

Alarm relay setting: Jumper 1 (JW1-AL2 Dry) provides field selection of the alarm relay terminal AL2 to be jumpered to 24VAC or to be a dry contact (no connection).
Not Clipped = AL2 connected to R. Clipped = AL2 dry contact (no connection).

DIP Switches

Note: In the following field configuration options, DIP switches should only be changed when power is removed from the CXM control.

DIP switch 1: Unit Performance Sentinel Disable - provides field selection to disable the UPS feature.

On = Enabled. Off = Disabled.

DIP switch 2: Stage 2 Selection - provides selection of

whether compressor has an “on” delay. If set to stage 2, the compressor will have a 3 second delay before energizing. Also, if set for stage 2, the alarm relay will NOT cycle during test mode.

On = Stage 1. Off = Stage 2

DIP switch 3: Not Used.

DIP switch 4: DDC Output at EH2 - provides selection for DDC operation. If set to “DDC Output at EH2,” the EH2 terminal will continuously output the last fault code of the controller. If set to “EH2 normal,” EH2 will operate as standard electric heat output.

On = EH2 Normal. Off = DDC Output at EH2.

NOTE: Some CXM controls only have a 2 position DIP switch package. If this is the case, this option can be selected by clipping the jumper which is in position 4 of SW1.

Jumper not clipped = EH2 Normal. Jumper clipped = DDC Output at EH2.

DIP switch 5: Factory Setting - Normal position is “On.” Do not change selection unless instructed to do so by the factory.

Table 5: CXM LED And Alarm Relay Operations

Description of Operation	LED	Alarm Relay
Normal Mode	On	Open
Normal Mode with UPS Warning	On	Cycle (closed 5 sec., Open 25 sec.)
CXM is non-functional	Off	Open
Fault Retry	Slow Flash	Open
Lockout	Fast Flash	Closed
Over/Under Voltage Shutdown	Slow Flash	Open (Closed after 15 minutes)
Test Mode - No fault in memory	Flashing Code 1	Cycling Code 1
Test Mode - HP Fault in memory	Flashing Code 2	Cycling Code 2
Test Mode - LP Fault in memory	Flashing Code 3	Cycling Code 3
Test Mode - FP1 Fault in memory	Flashing Code 4	Cycling Code 4
Test Mode - FP2 Fault in memory	Flashing Code 5	Cycling Code 5
Test Mode - CO Fault in memory	Flashing Code 6	Cycling Code 6
Test Mode - Over/Under shutdown in memory	Flashing Code 7	Cycling Code 7
Test Mode - UPS in memory	Flashing Code 8	Cycling Code 8
Test Mode - Swapped Thermistor	Flashing Code 9	Cycling Code 9

-Slow Flash = 1 flash every 2 seconds

-Fast Flash = 2 flashes every 1 second

-Flash code 2 = 2 quick flashes, 10 second pause, 2 quick flashes, 10 second pause, etc.

-On pulse 1/3 second; off pulse 1/3 second

CAUTION!

CAUTION! Do not restart units without inspection and remedy of faulting condition. Equipment damage may occur.

Safety Features

Safety Features – CXM Control

The safety features below are provided to protect the compressor, heat exchangers, wiring and other components from damage caused by operation outside of design conditions.

Anti-short cycle protection: The control features a 5 minute anti-short cycle protection for the compressor.

Note: The 5 minute anti-short cycle also occurs at power up.

Random start: The control features a random start upon power up of 5-80 seconds.

Fault Retry: In Fault Retry mode, the Status LED begins slowly flashing to signal that the control is trying to recover from a fault input. The control will stage off the outputs and then “try again” to satisfy the thermostat input call. Once the thermostat input call is satisfied, the control will continue on as if no fault occurred. If 3 consecutive faults occur without satisfying the thermostat input call, the control will go into “lockout” mode. The last fault causing the lockout will be stored in memory and can be viewed by going into test mode (CXM board).

Note: FP1/FP2 faults are factory set at only one try.

Lockout: In lockout mode, the status LED will begin fast flashing. The compressor relay is turned off immediately. Lockout mode can be “soft” reset by turning off the thermostat (or satisfying the call). A “soft” reset keeps the fault in memory but resets the control. A “hard” reset (disconnecting power to the control) resets the control and erases fault memory.

Lockout with emergency heat: While in lockout mode, if W becomes active (CXM), emergency heat mode will occur.

High pressure switch: When the high pressure switch opens due to high refrigerant pressures, the compressor relay is de-energized immediately since the high pressure switch is in series with the compressor contactor coil. The high pressure fault recognition is immediate (does not delay for 30 continuous seconds before de-energizing the compressor).

High pressure lockout code = 2

Example: 2 quick flashes, 10 sec pause, 2 quick flashes, 10 sec. pause, etc.

Low pressure switch: The low pressure switch must be open and remain open for 30 continuous seconds during “on” cycle to be recognized as a low pressure fault. If the low pressure switch is open for 30 seconds prior to compressor power up it will be considered a low pressure (loss of charge) fault. The low pressure switch input is bypassed for the initial 60 seconds of a compressor run cycle.

Low pressure lockout code = 3

Water coil low temperature (FP1): The FP1 thermistor temperature must be below the selected low temperature limit setting for 30 continuous seconds during a

compressor run cycle to be recognized as a FP1 fault. The FP1 input is bypassed for the initial 60 seconds of a compressor run cycle. FP1 is set at the factory for one try. Therefore, the control will go into lockout mode once the FP1 fault has occurred.

FP1 lockout code = 4

Air coil low temperature (FP2): The FP2 thermistor temperature must be below the selected low temperature limit setting for 30 continuous seconds during a compressor run cycle to be recognized as a FP2 fault.

The FP2 input is bypassed for the initial 60 seconds of a compressor run cycle. FP2 is set at the factory for one try. Therefore, the control will go into lockout mode once the FP2 fault has occurred.

FP2 lockout code = 5

Condensate overflow: The condensate overflow sensor must sense overflow level for 30 continuous seconds to be recognized as a CO fault. Condensate overflow will be monitored at all times.

CO lockout code = 6

Over/under voltage shutdown: An over/under voltage condition exists when the control voltage is outside the range of 19VAC to 30VAC. Over/under voltage shutdown is a self-resetting safety. If the voltage comes back within range for at least 0.5 seconds, normal operation is restored. This is not considered a fault or lockout. If the CXM is in over/under voltage shutdown for 15 minutes, the alarm relay will close.

Over/under voltage shut down code = 7

Unit Performance Sentinel-UPS (patent pending): The UPS feature indicates when the heat pump is operating inefficiently. A UPS condition exists when:

- a) In heating mode with compressor energized, FP2 is greater than 125°F [52°C] for 30 continuous seconds, or:

CXM Controls

- b) In cooling mode with compressor energized, FP1 is greater than 125°F [52°C] for 30 continuous seconds, or:
- c) In cooling mode with compressor energized, FP2 is less than 40°F [4.5°C] for 30 continuous seconds.

If a UPS condition occurs, the control will immediately go to UPS warning. The status LED will remain on as if the control is in normal mode. Outputs of the control, excluding LED and alarm relay, will NOT be affected by UPS. The UPS condition cannot occur during a compressor off cycle. During UPS warning, the alarm relay will cycle on and off. The cycle rate will be “on” for 5 seconds, “off” for 25 seconds, “on” for 5 seconds, “off” for 25 seconds, etc.

UPS warning code = 8

Swapped FP1/FP2 thermistors: During test mode, the control monitors to see if the FP1 and FP2 thermistors are in the appropriate places. If the control is in test mode, the control will lockout with code 9 after 30 seconds if:

- a) The compressor is on in the cooling mode and the FP1 sensor is colder than the FP2 sensor, or:
- b) The compressor is on in the heating mode and the FP2 sensor is colder than the FP1 sensor.

Diagnostic Features

The LED on the CXM board advises the technician of the current status of the CXM control. The LED can display either the current CXM mode or the last fault in memory if in test mode. If there is no fault in memory, the LED will flash Code 1 (when in test mode).

CXM Control Start-up Operation

The control will not operate until all inputs and safety controls are checked for normal conditions. The compressor will have a 5 minute anti-short cycle delay at power-up. The first time after power-up that there is a call for compressor, the compressor will follow a 5 to 80 second random start delay. After the random start delay and anti-short cycle delay, the compressor relay will be energized. On all subsequent compressor calls, the random start delay is omitted.

UNIT STARTING AND OPERATING CONDITIONS

Operating Limits

Environment – Units are designed for indoor installation only. Never install units in areas subject to freezing or where humidity levels could cause cabinet condensation (such as unconditioned spaces subject to 100% outside air).

Power Supply – A voltage variation of +/- 10% of nameplate utilization voltage is acceptable.

Determination of operating limits is dependent primarily upon three factors: 1) return air temperature. 2) water temperature, and 3) ambient temperature. When any one of these factors is at minimum or maximum levels, the other two factors should be at normal levels to insure proper unit operation. Extreme variations in temperature and humidity and/or corrosive water or air will adversely affect unit performance, reliability, and service life. Consult Table 6a for operating limits.

Table 6a: Operating Limits

Operating Limits	HB	
	Cooling	Heating
Air Limits		
Min. ambient air, DB	45°F [7°C]	39°F [4°C]
Rated ambient air, DB	80.6°F [27°C]	68°F [20°C]
Max. ambient air, DB	110°F [43°C]	85°F [29°C]
Min. entering air, DB/WB	65/50°F [18/10°C]	45°F [7.2°C]
Rated entering air, DB/WB	80.6/66.2°F [27/19°C]	68°F [20°C]
Max. entering air, DB/WB	95/75°F [35/24°C]	80°F [27°C]
Water Limits		
Min. entering water	30°F [-1°C]	20°F [-6.7°C]
Normal entering water	50-110°F [10-43°C]	30-70°F [-1 to 21°C]
Max. entering water	120°F [49°C]	90°F [32°C]
Normal Water Flow	1.5 to 3.0 gpm / ton [1.6 to 3.2 l/m per kW]	

Starting Conditions

Starting conditions are based upon the following notes:

Notes:

- Conditions in Table 6b are not normal or continuous operating conditions. Minimum/maximum limits are start-up conditions to bring the building space up to occupancy temperatures. Units are not designed to operate under these conditions on a regular basis.
- Voltage utilization range complies with AHRI Standard 110

Table 6b: Starting Limits

Commissioning Limits	HB	
	Cooling	Heating
Air Limits		
Min. ambient air, DB	45°F [7°C]	39°F [4°C]
Rated ambient air, DB	80.6°F [27°C]	68°F [20°C]
Max. ambient air, DB	110°F [43°C]	85°F [29°C]
Min. entering air, DB/WB	50/45°F [10/7°C]	40°F [4.5°C]
Rated entering air, DB/WB	80.6/66.2°F [27/19°C]	68°F [20°C]
Max. entering air, DB/WB	110/83°F [43/28°C]	80°F [27°C]
Water Limits		
Min. entering water	30°F [-1°C]	20°F [-6.7°C]
Normal entering water	50-110°F [10-43°C]	30-70°F [-1 to 21°C]
Max. entering water	120°F [49°C]	90°F [32°C]
Normal Water Flow	1.5 to 3.0 gpm / ton [1.6 to 3.2 l/m per kW]	

Piping System Cleaning and Flushing

Piping System Cleaning and Flushing

Cleaning and flushing the WLHP piping system is the single most important step to insure proper start-up and continued efficient operation of the system.

Follow the instructions below to properly clean and flush the system:

1. Insure that electrical power to the unit is disconnected.
2. Install the system with the supply hose connected directly to the return riser valve. Use a single length of flexible hose.
3. Open all air vents. Fill the system with water. DO NOT allow system to overflow. Bleed all air from the system. Pressurize and check the system for leaks and repair as appropriate.
4. Verify that all strainers are in place (Heat Controller recommends a strainer with a #20 stainless steel wire mesh). Start the pumps, and systematically check each vent to ensure that all air is bled from the system.
5. Verify that make-up water is available. Adjust make-up water as required to replace the air which was bled from the system. Check and adjust the water/air level in the expansion tank.
6. Set the boiler to raise the loop temperature to approximately 86°F [30°C]. Open a drain at the lowest point in the system. Adjust the make-up water replacement rate to equal the rate of bleed.
7. Refill the system and add trisodium phosphate in a proportion of approximately one pound per 150 gallons [1/2 kg per 750 l] of water (or other equivalent approved cleaning agent). Reset the boiler to raise the loop temperature to 100°F [38°C]. Circulate the solution for a minimum of 8 to 24 hours. At the end of this period, shut off the circulating pump and drain the solution. Repeat system cleaning if desired.
8. When the cleaning process is complete, remove the short-circuited hoses. Reconnect the hoses to the proper supply, and return the connections to each of the units. Refill the system and bleed off all air.
9. Test the system pH with litmus paper. The system water should be in the range of pH 6.0 - 8.5 (see table 3). Add chemicals, as appropriate to maintain neutral pH levels.
10. When the system is successfully cleaned, flushed, refilled and bled, check the main system panels, safety cutouts and alarms. Set the controls to properly maintain loop temperatures.

DO NOT use "Stop Leak" or similar chemical agent in this system. Addition of chemicals of this type to the loop water will foul the heat exchanger and inhibit unit operation.

NOTE: Heat Controller strongly recommends all piping connections, both internal and external to the unit, be pressure tested by an appropriate method prior to any finishing of the interior space or before access to all connections is limited. Test pressure may not exceed the maximum allowable pressure for the unit and all components within the water system. Heat Controller will not be responsible or liable for damages from water leaks due to inadequate or lack of a pressurized leak test, or damages caused by exceeding the maximum pressure rating during installation.

CAUTION!

CAUTION! To avoid possible damage to a plastic (PVC) piping system, do not allow temperatures to exceed 113°F [45°C].

UNIT AND SYSTEM CHECKOUT

Unit and System Checkout
BEFORE POWERING SYSTEM, please check the following:

UNIT CHECKOUT

- ▶▶ Balancing/shutoff valves: Insure that all isolation valves are open and water control valves are wired.
- ▶▶ Line voltage and wiring: Verify that voltage is within an acceptable range for the unit and wiring and fuses/breakers are properly sized. Verify that low voltage wiring is complete.
- ▶▶ Unit control transformer: Insure that transformer has the properly selected voltage tap. Commercial 208-230V units are factory wired for 208V operation unless specified otherwise.
- ▶▶ Entering water and air: Insure that entering water and air temperatures are within operating limits of Table 7.
- ▶▶ Low water temperature cutout: Verify that low water temperature cut-out on the CXM control is properly set.
- ▶▶ Unit fan: Manually rotate fan to verify free rotation and insure that blower wheel is secured to the motor shaft. Be sure to remove any shipping supports if needed. DO NOT oil motors upon start-up. Fan motors are pre-oiled at the factory. Check unit fan speed selection and compare to design requirements.
- ▶▶ Condensate line: Verify that condensate line is open and properly pitched toward drain.
- ▶▶ Water flow balancing: Record inlet and outlet water temperatures for each heat pump upon startup. This check can eliminate nuisance trip outs and high velocity water flow that could erode heat exchangers.
- ▶▶ Unit air coil and filters: Insure that filter is clean and accessible. Clean air coil of all manufacturing oils.
- ▶▶ Unit controls: Verify that CXM field selection options are properly set.

SYSTEM CHECKOUT

- ▶▶ System water temperature: Check water temperature for proper range and also verify heating and cooling set points for proper operation.
- ▶▶ System pH: Check and adjust water pH if necessary to maintain a level between 6 and 8.5. Proper pH promotes longevity of hoses and fittings (see table 3).

- ▶▶ System flushing: Verify that all hoses are connected end to end when flushing to insure that debris bypasses the unit heat exchanger, water valves and other components. Water used in the system must be potable quality initially and clean of dirt, piping slag, and strong chemical cleaning agents. Verify that all air is purged from the system. Air in the system can cause poor operation or system corrosion.
- ▶▶ Cooling tower/boiler: Check equipment for proper set points and operation.
- ▶▶ Standby pumps: Verify that the standby pump is properly installed and in operating condition.
- ▶▶ System controls: Verify that system controls function and operate in the proper sequence.
- ▶▶ Low water temperature cutout: Verify that low water temperature cut-out controls are provided for the outdoor portion of the loop. Otherwise, operating problems may occur.
- ▶▶ System control center: Verify that the control center and alarm panel have appropriate set points and are operating as designed.
- ▶▶ Miscellaneous: Note any questionable aspects of the installation.

CAUTION!

CAUTION! Verify that ALL water control valves are open and allow water flow prior to engaging the compressor. Freezing of the coax or water lines can permanently damage the heat pump.

CAUTION!

CAUTION! To avoid equipment damage, DO NOT leave system filled in a building without heat during the winter unless antifreeze is added to the water loop. Heat exchangers never fully drain by themselves and will freeze unless winterized with antifreeze.

NOTICE! Failure to remove shipping brackets from spring-mounted compressors will cause excessive noise, and could cause component failure due to added vibration.

Unit Start-Up Procedure

Unit Start-up Procedure

1. Turn the thermostat fan position to "ON". Blower should start.
 2. Balance air flow at registers.
 3. Adjust all valves to their full open positions. Turn on the line power to all heat pumps.
 4. Room temperature should be within the minimum-maximum ranges of table 6. During start-up checks, loop water temperature entering the heat pump should be between 60°F [16°C] and 95°F [35°C].
 5. Two factors determine the operating limits of Heat Controller heat pumps, (a) return air temperature, and (b) water temperature. When any one of these factors is at a minimum or maximum level, the other factor must be at normal level to insure proper unit operation.
 - a. Adjust the unit thermostat to the warmest setting. Place the thermostat mode switch in the "COOL" position. Slowly reduce thermostat setting until the compressor activates.
 - b. Check for cool air delivery at the unit grille within a few minutes after the unit has begun to operate. Note: Units have a five minute time delay in the control circuit that can be eliminated on the CXM control board as shown below in Figure 23. See controls description for details.
 - c. Verify that the compressor is on and that the water flow rate is correct by measuring pressure drop through the heat exchanger using the P/T plugs and comparing to tables 10.
 - d. Check the elevation and cleanliness of the condensate lines. Dripping may be a sign of a blocked line. Check that the condensate trap is filled to provide a water seal.
 - e. Refer to table 9. Check the temperature of both entering and leaving water. If temperature is within range, proceed with the test. If temperature is outside of the operating range, check refrigerant pressures and compare to tables 8a through 8d. Verify correct water flow by comparing unit pressure drop across the heat exchanger versus the data in tables 7. Heat of rejection (HR) can be calculated and compared to submittal data capacity pages. The formula for HR for systems with water is as follows:

$$HR \text{ (Btuh)} = TD \times GPM \times 500$$
 where TD is the temperature difference between the entering and leaving water, and GPM is the flow rate in U.S. GPM, determined by comparing the pressure drop across the heat exchanger to table 7. In S.I. units, the formula is as follows: $HR \text{ (kW)} = TD \times l/s \times 4.18$.
 - f. Check air temperature drop across the air coil when compressor is operating. Air temperature drop should be between 15°F and 25°F [8°C and 14°C].
 - g. Turn thermostat to "OFF" position. A hissing noise indicates proper functioning of the reversing valve.
6. Allow five (5) minutes between tests for pressure to equalize before beginning heating test.
 - a. Adjust the thermostat to the lowest setting. Place the thermostat mode switch in the "HEAT" position.
 - b. Slowly raise the thermostat to a higher temperature until the compressor activates.
 - c. Check for warm air delivery within a few minutes after the unit has begun to operate.
 - d. Refer to table 9. Check the temperature of both entering and leaving water. If temperature is within range, proceed with the test. If temperature is outside of the operating range, check refrigerant pressures and compare to tables 8a through 8d. Verify correct water flow by comparing unit pressure drop across the heat exchanger versus the data in tables 8a through 8d. Heat of extraction (HE) can be calculated and compared to submittal data capacity pages. The formula for HE for systems with water is as follows:

$$HE \text{ (Btuh)} = TD \times GPM \times 500$$
 where TD is the temperature difference between the entering and leaving water, and GPM is the flow rate in U.S. GPM, determined by comparing the pressure drop across the heat exchanger to tables 10a through 10e. In S.I. units, the formula is as follows: $HE \text{ (kW)} = TD \times l/s \times 4.18$.
 - e. Check air temperature rise across the air coil when compressor is operating. Air temperature rise should be between 20°F and 30°F [11°C and 17°C].
 - f. Check for vibration, noise, and water leaks.
 7. If unit fails to operate, perform troubleshooting analysis (see troubleshooting section). If the check described fails to reveal the problem and the unit still does not operate, contact a trained service technician to insure proper diagnosis and repair of the equipment.
 8. When testing is complete, set system to maintain desired comfort level.
 9. BE CERTAIN TO FILL OUT AND FORWARD ALL WARRANTY REGISTRATION PAPERS TO HEAT CONTROLLER.
- Note: If performance during any mode appears abnormal, refer to the CXM section or troubleshooting section of this manual. To obtain maximum performance, the air coil should be cleaned before start-up. A 10% solution of dishwasher detergent and water is recommended.

Unit Start-Up Procedure

Figure 23: Test Mode Pins

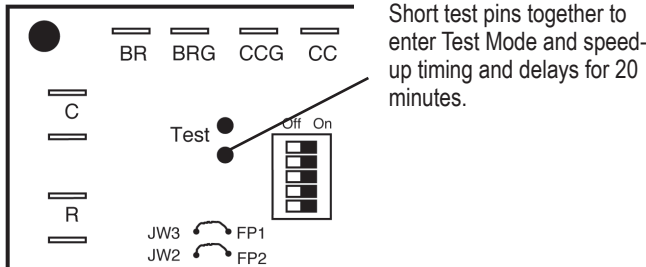

WARNING!

WARNING! When the disconnect switch is closed, high voltage is present in some areas of the electrical panel. Exercise caution when working with energized equipment.

CAUTION!

CAUTION! Verify that ALL water control valves are open and allow water flow prior to engaging the compressor. Freezing of the coax or water lines can permanently damage the heat pump.

UNIT OPERATING CONDITIONS

Table 7: HB Coax Water Pressure Drop

Model	U.S. GPM	l/s	Pressure Drop, psi [kPa]*			
			30°F [-1°C]	50°F [10°C]	70°F [21°C]	90°F [32°C]
006	0.75	0.05	0.5 (3.7)	0.3 (2.3)	0.2 (1.6)	0.2 (1.6)
	1.1	0.07	0.8 (5.3)	0.5 (3.5)	0.4 (2.7)	0.3 (2.2)
	1.5	0.09	1.3 (8.8)	0.9 (6.1)	0.7 (4.8)	0.6 (4.0)
009	1.1	0.07	1.3 (9.0)	0.6 (4.4)	0.4 (2.8)	0.3 (1.9)
	1.8	0.11	2.1 (14.1)	1.4 (9.4)	1.1 (7.4)	0.9 (6.2)
	2.3	0.14	3.5 (24.3)	2.6 (17.9)	2.1 (14.7)	1.8 (12.7)
012	1.5	0.09	1.9 (12.8)	1.1 (7.6)	0.8 (5.3)	0.6 (4.1)
	2.3	0.15	3.6 (25.0)	2.6 (17.8)	2.1 (14.3)	1.8 (12.1)
	3.0	0.19	6.7 (46.1)	5.0 (34.3)	4.1 (28.3)	3.6 (24.5)
015	1.9	0.12	1.0 (6.9)	0.6 (4.4)	0.5 (3.4)	0.4 (2.8)
	2.8	0.18	1.8 (12.4)	1.4 (9.3)	1.1 (7.6)	1.0 (6.9)
	3.8	0.24	3.3 (22.7)	2.5 (17.5)	2.1 (14.7)	1.9 (13.1)
018	2.3	0.14	2.1 (14.5)	1.4 (9.9)	1.1 (7.6)	0.9 (6.2)
	3.4	0.21	3.4 (23.4)	2.6 (17.6)	2.1 (14.7)	1.8 (12.4)
	4.5	0.28	5.9 (40.6)	4.6 (31.5)	3.9 (26.9)	3.4 (23.4)
024	3.0	0.19	2.2 (15.2)	1.7 (11.6)	1.4 (9.6)	1.2 (8.3)
	4.5	0.28	4.0 (27.6)	3.2 (22.2)	2.8 (19.3)	2.5 (17.2)
	6.0	0.38	7.2 (49.6)	5.9 (40.6)	5.2 (35.8)	4.7 (32.4)
030	3.8	0.24	1.3 (9.0)	0.9 (6.1)	0.7 (4.8)	0.6 (4.1)
	5.6	0.35	2.3 (15.8)	1.8 (12.5)	1.5 (10.3)	1.4 (9.6)
	7.5	0.47	4.2 (28.9)	3.4 (23.2)	2.9 (20)	2.6 (17.9)
036	4.5	0.28	1.8 (12.4)	1.4 (9.6)	1.2 (8.3)	1.0 (6.9)
	6.8	0.43	3.1 (21.4)	2.4 (16.8)	2.1 (14.7)	1.9 (13.1)
	9.0	0.57	5.4 (37.2)	4.4 (30.0)	3.8 (26.2)	3.4 (23.4)
042	5.3	0.33	2.3 (15.8)	1.8 (12.1)	1.5 (10.3)	1.3 (9.0)
	7.9	0.50	4.3 (29.6)	3.5 (24.2)	3.1 (26.4)	2.8 (19.3)
	10.5	0.66	7.9 (54.4)	6.5 (44.8)	5.7 (39.3)	5.2 (35.8)
048	6.0	.038	1.8 (12.4)	1.5 (10.1)	1.3 (9.0)	1.2 (8.3)
	9.0	0.57	3.4 (23.4)	3.0 (20.4)	2.7 (18.6)	2.6 (17.9)
	12.0	0.76	6.2 (42.7)	5.5 (37.9)	5.1 (35.1)	4.8 (35.1)
060	7.5	0.47	3.4 (23.4)	2.8 (19.2)	2.4 (16.5)	2.2 (15.2)
	11.3	0.71	6.8 (46.9)	5.9 (40.8)	5.4 (37.2)	5.0 (34.5)
	15.0	0.95	12.6 (86.8)	11.1 (76.8)	10.3 (71.0)	9.6 (66.1)

*Note: To convert kPa to millibars, multiply by 10.

Unit Operating Pressures and Temperatures

Operating Pressure/Temperature tables include the following notes:

- Airflow is at nominal (rated) conditions;
- Entering air is based upon 70°F [21°C] DB in heating and 80/67°F [27/19°C] in cooling;
- Subcooling is based upon head pressure at compressor service port;
- Cooling air and water values can vary greatly with changes in humidity level.

Table 8a: HB Series Typical Unit Operating Pressures and Temperatures (60 Hz-I.P. Units)

HBH/V006		Cooling						Heating					
Entering Water Temp °F	Water Flow GPM/ton	Suction Pressure PSIG	Discharge Pressure PSIG	Super-heat	Sub-cooling	Water Temp Rise °F	Air Temp Drop °F DB	Suction Pressure PSIG	Discharge Pressure PSIG	Super-heat	Sub-cooling	Water Temp Drop °F	Air Temp Rise °F DB
30	1.5	124-134	159-179	17-22	5-10	18.7-20.7	17-23	71-81	295-315	13-18	5-10	5.9-7.9	17-23
	2.25	120-130	147-167	20-25	5-10	13.6-15.6	18-24	72-82	296-316	14-19	5-10	4.2-6.2	17-23
	3	117-127	136-156	24-29	5-10	8.5-10.5	18-24	74-84	297-317	15-20	5-10	2.5-4.5	17-23
50	1.5	132-142	210-230	7-12	5-10	16.2-18.2	18-24	105-115	330-350	8-13	9-14	8.2-10.2	22-28
	2.25	131-141	199-219	8-13	5-10	11.9-13.9	19-25	110-120	335-355	9-14	9-14	6.1-8.1	22-28
	3	130-140	189-209	9-14	4-9	7.7-9.7	19-25	115-125	339-359	9-14	9-14	4-6	23-29
70	1.5	136-146	275-295	5-10	5-10	15.1-17.1	17-23	136-146	362-382	9-14	10-15	11.3-13.3	27-33
	2.25	136-146	262-282	6-11	4-9	11.1-13.1	18-24	141-151	368-388	9-14	10-15	16.9-18.9	28-34
	3	135-145	250-270	6-11	4-9	7.2-9.2	18-24	147-157	374-394	9-14	10-15	5.6-7.6	29-35
90	1.5	142-152	365-385	5-10	4-9	13.8-15.8	16-22	170-180	402-422	14-19	12-17	14.4-16.4	33-39
	2.25	141-151	353-373	5-10	4-9	10.2-12.2	16-22	173-183	407-427	15-20	12-17	11.1-13.1	33-39
	3	140-150	340-360	5-10	4-9	6.6-8.6	16-22	177-187	412-432	17-22	12-17	7.7-9.1	34-40
110	1.5	148-158	462-482	5-10	4-9	12.5-14.5	14-20						
	2.25	147-157	449-469	5-10	3-8	9.2-11.2	14-20						
	3	146-156	438-458	5-10	3-8	5.9-7.9	14-20						

HBH/V009		Cooling						Heating					
Entering Water Temp °F	Water Flow GPM/ton	Suction Pressure PSIG	Discharge Pressure PSIG	Super-heat	Sub-cooling	Water Temp Rise °F	Air Temp Drop °F DB	Suction Pressure PSIG	Discharge Pressure PSIG	Super-heat	Sub-cooling	Water Temp Drop °F	Air Temp Rise °F DB
30	1.5	113-123	160-180	22-27	13-18	19.5-21.5	17-23	69-79	331-351	11-16	20-25	7.3-9.3	17-23
	2.25	110-120	147-167	25-30	11-16	14.2-16.2	17-23	72-82	335-355	11-16	20-25	5.4-7.4	18-24
	3	108-118	135-155	28-33	9-14	8.9-10.9	16-21	75-85	339-359	11-16	21-26	3.5-5.5	19-25
50	1.5	124-134	211-231	9-14	10-15	18-20	17-23	101-111	360-380	9-14	20-25	9.8-11.8	23-29
	2.25	122-132	199-219	12-17	9-14	13.2-15.2	17-23	105-115	363-383	9-14	19-24	7.4-9.4	24-30
	3	120-130	187-207	15-20	8-13	8.4-10.4	17-23	110-120	366-386	9-14	19-24	4.9-6.9	24-30
70	1.5	129-139	275-295	7-12	8-13	17.4-19.4	16-22	130-140	400-420	10-15	20-25	12.8-14.8	28-34
	2.25	128-138	261-281	8-13	7-12	12.8-14.8	16-22	137-147	407-427	10-15	19-24	9.6-11.6	29-35
	3	127-137	247-267	8-13	6-11	8.2-10.2	16-22	144-154	414-434	10-15	18-23	6.4-8.4	30-36
90	1.5	136-146	364-384	7-12	3-8	15.7-17.7	15-21	170-180	449-469	13-18	17-22	16-18	34-40
	2.25	135-145	350-370	7-12	4-9	11.7-13.7	15-21	178-188	455-475	14-19	15-20	12-14	35-41
	3	134-144	336-356	7-12	4-9	7.6-9.6	15-21	186-196	460-480	15-20	13-18	7.9-9.9	36-42
110	1.5	142-152	467-487	5-10	4-9	13.5-15.5	13-19						
	2.25	141-151	451-471	5-10	4-9	9.9-11.9	13-19						
	3	140-150	435-455	5-10	3-8	6.3-8.3	13-19						

HBH/V012		Cooling						Heating					
Entering Water Temp °F	Water Flow GPM/ton	Suction Pressure PSIG	Discharge Pressure PSIG	Super-heat	Sub-cooling	Water Temp Rise °F	Air Temp Drop °F DB	Suction Pressure PSIG	Discharge Pressure PSIG	Super-heat	Sub-cooling	Water Temp Drop °F	Air Temp Rise °F DB
30	1.5	116-126	155-175	14-19	9-14	19.4-21.4	18-24	70-80	311-331	8-13	8-13	6.9-8.9	18-24
	2.25	113-123	144-164	15-20	8-13	14.3-16.3	18-24	72-82	315-335	8-13	8-13	5.1-7.1	19-25
	3	111-121	132-152	17-22	6-11	9.1-11.1	18-24	75-85	319-339	8-13	8-13	3.2-5.2	19-25
50	1.5	123-133	208-228	8-13	9-14	18.1-20.1	17-23	102-112	354-364	8-13	9-14	9.3-11.3	25-31
	2.25	122-132	196-216	9-14	7-12	13.4-15.4	18-24	106-116	355-375	8-13	9-14	7-9	26-32
	3	121-131	184-204	9-14	5-10	8.6-10.6	18-24	110-120	355-375	8-13	9-14	4.6-6.6	26-32
70	1.5	127-137	266-286	7-12	8-13	17.2-19.2	16-22	131-141	392-412	9-14	8-13	12-14	30-36
	2.25	126-136	255-275	8-13	7-12	12.7-14.7	16-22	137-147	395-415	9-14	8-13	9-11	31-37
	3	126-136	244-264	8-13	5-10	8.2-10.2	16-22	144-154	398-418	9-14	7-12	6-8	32-38
90	1.5	133-143	362-382	6-11	7-12	16-18	15-21	175-185	443-463	10-15	3-8	15-17	36-42
	2.25	132-142	342-362	7-12	5-10	11.8-13.8	15-21	183-193	452-472	11-16	3-8	11.2-13.2	37-43
	3	132-142	331-351	7-12	4-9	7.6-9.6	15-21	190-200	461-491	13-18	3-8	7.4-9.4	38-44
110	1.5	140-150	459-479	6-11	4-9	14.4-16.4	13-19						
	2.25	140-150	441-461	6-11	4-9	10.6-12.6	13-19						
	3	139-149	431-451	6-11	3-8	6.9-8.9	13-19						

Unit Operating Pressures and Temperatures

Table 8b: HB Series Typical Unit Operating Pressures and Temperatures (60 Hz-I.P. Units)

HBH/V015		Cooling						Heating					
Entering Water Temp °F	Water Flow GPM/ton	Suction Pressure PSIG	Discharge Pressure PSIG	Super-heat	Sub-cooling	Water Temp Rise °F	Air Temp Drop °F DB	Suction Pressure PSIG	Discharge Pressure PSIG	Super-heat	Sub-cooling	Water Temp Drop °F	Air Temp Rise °F DB
30	1.5	116-126	167-187	15-20	9-14	18.3-20.3	18-24	70-80	279-299	6-11	1-5	7-8	16-22
	2.25	116-126	154-174	15-20	7-12	13.9-15.9	19-25	73-83	281-301	7-12	1-5	5.1-7.1	17-23
	3	116-126	140-160	15-20	7-12	9.5-11.5	19-25	75-85	284-304	7-12	1-5	3.3-5.3	17-23
50	1.5	128-138	194-214	11-14	9-14	17.9-19.9	18-24	102-112	312-332	10-15	2-6	9.9-11.9	22-28
	2.25	128-138	180-200	11-14	7-12	13.7-15.7	19-25	106-116	316-336	10-15	2-6	7.4-9.4	23-29
	3	128-138	166-186	11-14	7-12	9.4-11.4	19-25	110-120	321-341	10-15	2-6	4.9-6.9	23-29
70	1.5	136-146	289-309	7-12	9-14	17.4-19.4	17-23	128-138	335-355	12-17	3-8	12.9-14.9	27-34
	2.25	136-146	275-295	7-12	7-12	15.3-17.3	18-24	134-144	340-360	12-17	3-8	9.7-11.7	28-35
	3	136-146	261-281	7-12	6-11	8.8-10.8	18-24	141-151	346-366	12-17	3-8	6.5-8.5	28-35
90	1.5	139-149	386-406	6-11	9-14	16.8-18.8	16-22	160-170	373-393	15-20	3-8	15.8-17.8	30-38
	2.25	139-149	370-390	6-11	7-12	12.5-14.5	16-22	167-177	380-400	16-21	3-8	12-14	31-39
	3	139-149	356-376	6-11	6-11	8.2-9.2	16-22	174-184	388-408	17-22	3-8	8.1-10.1	32-40
110	1.5	145-155	483-503	6-11	9-14	15.8-17.8	15-21						
	2.25	144-154	466-486	6-11	7-12	11.7-13.7	15-21						
	3	143-153	449-469	6-11	6-11	7.5-9.5	15-21						

HBH/V018		Cooling						Heating					
Entering Water Temp °F	Water Flow GPM/ton	Suction Pressure PSIG	Discharge Pressure PSIG	Super-heat	Sub-cooling	Water Temp Rise °F	Air Temp Drop °F DB	Suction Pressure PSIG	Discharge Pressure PSIG	Super-heat	Sub-cooling	Water Temp Drop °F	Air Temp Rise °F DB
30	1.5	122-132	171-191	15-20	14-19	22.5-24.5	20-28	70-80	272-292	4-9	2-6	7.4-9.4	18-24
	2.25	122-132	157-177	15-20	13-18	16.8-19.8	20-28	73-83	275-295	4-9	2-6	5.5-7.5	19-25
	3	122-132	145-165	15-20	13-18	11.2-13.2	20-28	77-87	278-298	4-9	2-6	3.5-5.5	19-25
50	1.5	136-146	198-218	10-15	14-19	22-24	19-25	101-111	302-322	8-13	3-7	10.3-12.3	23-29
	2.25	134-144	183-203	10-15	13-18	16.5-18.5	19-25	105-115	306-326	8-13	3-7	7.9-9.9	24-30
	3	133-143	171-191	11-16	13-18	11-13	19-25	109-119	311-331	8-13	3-7	5.5-7.5	25-31
70	1.5	139-149	293-313	6-10	14-19	19-21	18-24	130-140	329-349	10-15	4-9	13.6-15.6	27-33
	2.25	138-148	280-300	6-10	13-18	14.4-16.4	18-24	137-147	337-357	10-15	4-9	10.4-12.4	29-35
	3	137-147	267-287	7-11	13-18	9.8-11.7	18-24	139-149	342-362	10-15	4-9	7.2-9.2	30-36
90	1.5	142-152	389-409	5-10	17-22	16-18	17-23	160-170	360-380	13-18	5-10	17-19	33-41
	2.25	141-151	376-396	5-10	15-20	12.3-14.3	17-23	169-179	368-388	14-19	5-10	12.9-14.9	35-43
	3	140-150	363-383	5-10	13-18	8.5-10.5	17-23	178-188	376-396	14-19	4-9	8.8-10.8	36-44
110	1.5	148-158	486-506	5-10	17-22	14.9-16.9	16-22						
	2.25	147-157	472-492	5-10	15-20	11.4-13.4	16-22						
	3	146-156	458-478	5-10	13-18	7.8-9.8	16-22						

HBH/V024		Cooling						Heating					
Entering Water Temp °F	Water Flow GPM/ton	Suction Pressure PSIG	Discharge Pressure PSIG	Super-heat	Sub-cooling	Water Temp Rise °F	Air Temp Drop °F DB	Suction Pressure PSIG	Discharge Pressure PSIG	Super-heat	Sub-cooling	Water Temp Drop °F	Air Temp Rise °F DB
30	1.5	121-131	174-194	13-18	6-11	19.3-21.3	20-28	65-75	287-307	4-9	3-8	6.8-8.8	17-23
	2.25	120-130	165-185	13-18	5-10	14.5-16.5	20-28	68-78	290-310	5-10	3-8	5-7	18-24
	3	120-130	155-175	13-18	5-10	9.6-11.6	20-28	71-81	292-312	5-10	3-8	3.2-5.2	18-24
50	1.5	127-137	245-265	8-13	6-11	18.3-20.3	19-27	96-106	318-338	6-11	3-8	9.8-11.8	22-28
	2.25	128-138	231-251	8-13	7-12	13.7-15.7	19-27	101-111	322-342	7-12	3-8	7.2-9.2	23-29
	3	128-138	217-237	8-13	7-12	9.1-11.1	19-27	105-115	327-347	8-13	3-8	4.8-6.8	24-30
70	1.5	130-140	352-372	6-11	8-13	17.5-19.5	18-26	127-137	349-369	9-14	3-8	12.7-14.7	27-34
	2.25	130-140	334-354	6-11	9-14	26.2-28.2	18-26	132-142	353-373	9-14	3-8	9.5-11.5	28-35
	3	130-140	306-326	6-11	9-14	8.7-10.7	18-26	137-147	358-378	10-15	3-8	6.3-8.3	29-36
90	1.5	134-144	439-459	5-10	11-16	16.7-18.7	17-23	159-169	379-399	13-18	3-8	15.6-17.6	32-40
	2.25	133-143	416-436	5-10	12-17	12.5-14.5	17-23	164-174	384-404	14-19	3-8	11.7-13.7	33-41
	3	133-143	394-414	5-10	12-17	8.3-10.3	17-23	170-180	390-410	16-21	3-8	7.8-9.8	34-42
110	1.5	140-150	536-556	4-9	22-27	17.1-19.1	17-23						
	2.25	139-149	512-532	4-9	19-23	12.6-14.6	17-23						
	3	138-148	488-508	4-9	17-22	8-10	17-23						

Unit Operating Pressures and Temperatures

Table 8c: HB Series Typical Unit Operating Pressures and Temperatures (60 Hz-I.P. Units)

HBH/V030		Cooling						Heating					
Entering Water Temp °F	Water Flow GPM/ton	Suction Pressure PSIG	Discharge Pressure PSIG	Super-heat	Sub-cooling	Water Temp Rise °F	Air Temp Drop °F DB	Suction Pressure PSIG	Discharge Pressure PSIG	Super-heat	Sub-cooling	Water Temp Drop °F	Air Temp Rise °F DB
30	1.5	113-123	188-208	14-19	14-19	19.5-21.5	18-26	67-77	322-342	8-13	15-20	6.9-8.9	17-25
	2.25	114-124	177-197	14-19	13-18	14.5-16.5	19-27	69-79	324-344	8-13	15-20	5.1-7.1	18-26
	3	114-124	166-186	14-19	13-18	9.5-11.5	19-27	71-81	326-346	8-13	15-20	3.3-5.3	18-26
50	1.5	124-134	248-268	11-16	14-19	18.7-20.7	18-26	95-105	346-366	10-15	15-20	9.8-11.8	23-31
	2.25	124-134	233-253	11-16	13-18	13.9-15.9	19-27	99-109	350-370	10-15	15-20	7.3-9.3	24-32
	3	124-134	218-238	11-16	13-18	9.1-11.1	19-27	103-113	355-375	11-16	15-20	4.8-6.8	25-33
70	1.5	132-142	333-353	9-14	13-18	17.5-19.5	18-26	125-135	376-396	13-18	14-19	12.7-14.7	27-35
	2.25	132-142	313-333	9-14	12-17	13-15	18-26	133-143	386-406	13-18	14-19	9.8-11.8	28-36
	3	132-142	293-313	9-14	12-17	8.5-10.5	18-26	136-146	393-413	13-18	14-19	6.4-8.4	30-38
90	1.5	135-145	431-451	7-12	17-22	16.5-18.5	17-25	155-165	415-435	15-20	13-18	15.6-18.6	33-41
	2.25	135-145	411-431	7-12	15-20	12.3-14.3	17-25	167-177	422-442	16-21	13-18	11.8-13.8	34-42
	3	135-145	391-411	7-12	13-18	8-10	17-25	170-180	430-450	17-22	13-18	7.9-9.9	36-44
110	1.5	140-150	528-548	6-11	17-22	16.2-18.2	16-24						
	2.25	140-150	506-526	7-12	15-20	11.9-13.9	16-24						
	3	139-149	485-505	7-12	13-18	7.6-9.6	16-24						

HBH/V036		Cooling						Heating					
Entering Water Temp °F	Water Flow GPM/ton	Suction Pressure PSIG	Discharge Pressure PSIG	Super-heat	Sub-cooling	Water Temp Rise °F	Air Temp Drop °F DB	Suction Pressure PSIG	Discharge Pressure PSIG	Super-heat	Sub-cooling	Water Temp Drop °F	Air Temp Rise °F DB
30	1.5	113-123	185-205	17-22	9-14	19.5-21.5	18-26	64-74	327-347	4-9	15-20	7.7-9.7	19-27
	2.25	113-123	174-194	17-22	8-13	14.5-16.5	19-27	66-76	331-351	4-9	15-20	5.7-7.7	19-27
	3	113-123	163-183	17-22	8-13	9.6-11.6	19-27	69-79	335-365	4-9	15-20	3.7-5.7	20-28
50	1.5	121-131	249-269	12-17	9-14	19.4-21.4	17-25	91-101	360-380	10-15	15-20	11.2-13.2	25-33
	2.25	120-130	231-251	12-17	8-13	14.4-16.4	18-26	96-106	370-390	9-14	16-21	8.2-10.2	26-34
	3	120-130	214-234	12-17	8-13	9.4-11.4	18-26	102-112	380-400	8-13	16-21	5.2-7.2	27-35
70	1.5	128-138	327-347	9-14	13-18	19.1-21.1	16-24	125-135	402-422	10-15	14-19	14.7-16.7	32-40
	2.25	128-138	304-324	9-14	11-16	14.1-16.1	17-25	132-142	413-433	10-15	14-19	11-13	33-41
	3	127-137	282-302	9-14	10-15	9.1-11.1	17-25	140-150	423-443	10-15	14-19	7.3-9.3	34-42
90	1.5	132-142	416-436	8-13	20-25	18.8-20.8	15-23	158-168	445-465	13-18	12-17	18.1-20.1	37-45
	2.25	132-142	396-416	8-13	18-23	13.9-15.9	16-24	167-177	456-476	13-18	11-16	13.8-15.8	38-46
	3	131-141	376-396	8-13	16-21	8.9-10.9	16-24	177-187	467-487	14-19	11-16	9.4-11.4	40-48
110	1.5	138-148	550-570	8-13	20-25	18.5-20.5	15-23						
	2.25	136-146	525-545	8-13	18-23	13.6-15.6	15-23						
	3	135-145	500-520	8-13	16-21	8.7-10.7	15-23						

HBH/V042		Cooling						Heating					
Entering Water Temp °F	Water Flow GPM/ton	Suction Pressure PSIG	Discharge Pressure PSIG	Super-heat	Sub-cooling	Water Temp Rise °F	Air Temp Drop °F DB	Suction Pressure PSIG	Discharge Pressure PSIG	Super-heat	Sub-cooling	Water Temp Drop °F	Air Temp Rise °F DB
30	1.5	115-125	174-194	12-17	10-15	19.8-21.8	16-24	66-76	314-334	6-11	11-16	7.3-9.3	18-26
	2.25	115-125	159-179	12-17	9-14	14.6-16.6	16-24	69-79	318-338	5-10	12-17	5.4-7.4	19-27
	3	115-125	144-164	12-17	9-14	9.5-11.5	16-24	72-82	321-341	4-9	12-17	3.4-5.4	19-27
50	1.5	123-133	233-253	9-14	10-15	19-21	16-24	97-107	354-374	9-14	13-18	10.2-12.2	24-32
	2.25	122-132	219-239	9-14	9-14	14-16	16-24	101-111	360-380	8-13	13-18	7.6-9.6	25-33
	3	122-132	205-225	9-14	9-14	9.1-11.1	16-24	106-116	365-385	6-11	13-18	5-7	26-34
70	1.5	128-138	309-329	6-11	12-17	18.3-20.3	16-24	130-140	394-414	7-12	13-18	13.3-15.3	30-38
	2.25	128-138	290-310	6-11	11-14	13.5-15.5	16-24	136-146	401-421	7-12	13-18	9.9-11.9	31-39
	3	128-138	271-291	6-11	11-14	8.7-10.7	16-24	143-153	409-429	8-13	13-18	6.6-8.6	32-40
90	1.5	133-143	406-426	5-10	14-19	17.6-19.6	16-24	164-174	434-454	10-15	12-17	16.4-18.4	37-45
	2.25	133-143	386-406	5-10	13-18	12.9-14.9	16-24	172-182	443-463	11-16	12-17	12.3-14.3	38-46
	3	132-142	367-387	5-10	13-18	8.3-10.3	16-24	180-190	453-473	11-16	12-17	8.3-10.3	39-47
110	1.5	138-148	505-525	5-10	19-24	16.8-18.8	16-24						
	2.25	138-148	484-504	5-10	16-21	12.4-14.4	16-24						
	3	138-148	463-483	5-10	14-19	7.9-9.9	16-24						

Unit Operating Pressures and Temperatures

Table 8d: HB Series Typical Unit Operating Pressures and Temperatures (60 Hz-I.P. Units)

HBH/V048		Cooling						Heating					
Entering Water Temp °F	Water Flow GPM/ton	Suction Pressure PSIG	Discharge Pressure PSIG	Super-heat	Sub-cooling	Water Temp Rise °F	Air Temp Drop °F DB	Suction Pressure PSIG	Discharge Pressure PSIG	Super-heat	Sub-cooling	Water Temp Drop °F	Air Temp Rise °F DB
30	1.5	119-129	190-210	15-20	10-15	19.3-21.3	18-26	63-73	284-304	5-10	3-8	6.9-8.9	17-25
	2.25	119-129	179-199	15-20	9-14	14.6-16.6	19-27	66-76	288-308	6-10	3-8	5-7	18-26
	3	119-129	158-178	15-20	9-14	9.8-11.8	19-27	69-79	292-312	6-11	3-8	3.1-5.1	18-26
50	1.5	124-134	248-268	10-15	10-15	19-21	18-26	92-102	309-329	8-13	3-8	9.5-11.5	23-31
	2.25	123-133	230-250	10-15	9-14	14.3-16.3	19-27	96-106	313-333	9-14	3-8	7-9	24-32
	3	123-133	213-233	10-15	9-14	9.6-11.6	19-27	100-110	317-337	9-14	3-8	4.6-6.6	24-32
70	1.5	129-139	337-357	8-13	12-17	18.6-20.6	17-25	123-133	339-359	11-16	3-8	12.5-14.5	29-37
	2.25	129-139	328-348	8-13	11-16	14-16	18-26	128-138	344-364	11-16	3-8	9.3-11.3	29-37
	3	129-139	300-320	8-13	11-16	9.4-11.4	18-26	133-143	350-370	12-17	3-8	6.2-8.2	30-38
90	1.5	134-144	426-446	6-11	15-20	18.2-20.2	16-24	153-163	369-389	14-19	1-6	15.4-17.4	33-41
	2.25	134-144	406-426	6-11	15-20	13.7-15.7	17-25	160-170	376-396	15-20	1-6	11.6-13.6	35-43
	3	134-144	386-406	6-11	15-20	9.2-11.2	17-25	167-177	384-404	16-21	1-6	7.8-9.8	36-44
110	1.5	140-150	560-580	4-9	23-28	17.7-19.7	16-24						
	2.25	140-150	536-556	4-9	20-25	13.4-15.4	16-24						
	3	139-149	511-531	4-9	18-22	9-11	16-24						

HBH/V060		Cooling						Heating					
Entering Water Temp °F	Water Flow GPM/ton	Suction Pressure PSIG	Discharge Pressure PSIG	Super-heat	Sub-cooling	Water Temp Rise °F	Air Temp Drop °F DB	Suction Pressure PSIG	Discharge Pressure PSIG	Super-heat	Sub-cooling	Water Temp Drop °F	Air Temp Rise °F DB
30	1.5	108-118	180-200	16-21	10-15	20.6	19-27	61-71	314-334	6-11	14-19	7.6-9.6	19-27
	2.25	108-118	165-185	16-21	9-14	15.2-17.2	20-28	64-74	317-337	7-12	13-18	5.6-7.6	20-28
	3	108-118	150-170	16-21	9-14	9.7-11.7	20-28	66-76	319-339	7-12	13-18	3.6-5.6	20-28
50	1.5	113-123	206-226	11-14	10-15	19.8-21.8	18-26	90-100	350-370	11-16	14-19	10.5-12.5	25-33
	2.25	113-123	190-210	11-14	9-14	14.5-16.5	19-27	95-105	357-377	11-16	14-19	7.9-9.9	27-35
	3	113-123	173-193	11-14	9-14	9.3-11.3	19-27	99-109	364-384	10-15	14-19	5.2-7.2	28-36
70	1.5	119-129	305-325	9-14	12-17	18.8-20.8	17-25	123-133	391-411	12-17	14-19	13.7-15.7	33-41
	2.25	118-128	287-307	9-14	11-14	13.8-15.8	18-26	129-139	399-419	12-17	14-19	10.3-12.3	34-42
	3	118-128	269-289	9-14	11-14	8.8-10.8	18-26	135-145	407-427	13-18	14-19	6.9-8.9	35-43
90	1.5	124-134	402-422	7-12	14-19	17.8-19.8	16-24	157-167	431-451	13-18	13-18	16.8-18.8	38-46
	2.25	124-134	382-402	7-12	13-18	13.1-15.1	17-25	164-184	440-460	14-19	13-18	12.7-14.7	39-47
	3	123-133	363-383	7-12	13-18	8.3-10.3	17-25	172-182	450-470	16-21	12-17	8.6-10.6	41-49
110	1.5	130-140	500-520	7-12	20-25	17-19	16-24						
	2.25	129-139	479-499	6-11	16-21	12.4-14.4	16-24						
	3	128-138	458-478	5-10	13-18	7.8-9.8	16-24						

Table 9: Water Temperature Change Through Heat Exchanger

Water Flow, gpm [l/m]	Rise, Cooling °F, [°C]	Drop, Heating °F, [°C]
For Closed Loop: Ground Source or Closed Loop Systems at 3 gpm per ton [3.2 l/m per kW]	9 - 12 [5 - 6.7]	4 - 8 [2.2 - 4.4]
For Open Loop: Ground Water Systems at 1.5 gpm per ton [1.6 l/m per kW]	20 - 26 [11.1 - 14.4]	10 - 17 [5.6 - 9.4]

Preventive Maintenance

Water Coil Maintenance

(Direct ground water applications only)

If the system is installed in an area with a known high mineral content (125 P.P.M. or greater) in the water, it is best to establish a periodic maintenance schedule with the owner so the coil can be checked regularly. Consult the well water applications section of this manual for a more detailed water coil material selection. Should periodic coil cleaning be necessary, use standard coil cleaning procedures, which are compatible with the heat exchanger material and copper water lines. Generally, the more water flowing through the unit, the less chance for scaling. Therefore, 1.5 gpm per ton [1.6 l/m per kW] is recommended as a minimum flow. Minimum flow rate for entering water temperatures below 50°F [10°C] is 2.0 gpm per ton [2.2 l/m per kW].

Water Coil Maintenance

(All other water loop applications)

Generally water coil maintenance is not needed for closed loop systems. However, if the piping is known to have high dirt or debris content, it is best to establish a periodic maintenance schedule with the owner so the water coil can be checked regularly. Dirty installations are typically the result of deterioration of iron or galvanized piping or components in the system. Open cooling towers requiring heavy chemical treatment and mineral buildup through water use can also contribute to higher maintenance. Should periodic coil cleaning be necessary, use standard coil cleaning procedures, which are compatible with both the heat exchanger material and copper water lines. Generally, the more water flowing through the unit, the less chance for scaling. However, flow rates over 3 gpm per ton (3.9 l/m per kW) can produce water (or debris) velocities that can erode the heat exchanger wall and ultimately produce leaks.

Filters

Filters must be clean to obtain maximum performance. Filters should be inspected every month under normal operating conditions and be replaced when necessary. Units should never be operated without a filter.

Washable, high efficiency, electrostatic filters, when dirty, can exhibit a very high pressure drop for the fan motor and reduce air flow, resulting in poor performance. It is especially important to provide consistent washing of these filters (in the opposite direction of the normal air flow) once per month using a high pressure wash similar to those found at self-serve car washes.

Condensate Drain

In areas where airborne bacteria may produce a “slimy” substance in the drain pan, it may be necessary to treat the drain pan chemically with an algaecide approximately every three months to minimize the problem. The condensate pan may also need to be cleaned periodically to insure indoor air quality. The condensate drain can pick up lint and dirt, especially with dirty filters. Inspect the drain twice a year to avoid the possibility of plugging and eventual overflow.

Compressor

Conduct annual amperage checks to insure that amp draw is no more than 10% greater than indicated on the serial plate data.

Fan Motors

All units have lubricated fan motors. Fan motors should never be lubricated unless obvious, dry operation is suspected. Periodic maintenance oiling is not recommended, as it will result in dirt accumulating in the excess oil and cause eventual motor failure. Conduct annual dry operation check and amperage check to insure amp draw is no more than 10% greater than indicated on serial plate data.

Air Coil

The air coil must be cleaned to obtain maximum performance. Check once a year under normal operating conditions and, if dirty, brush or vacuum clean. Care must be taken not to damage the aluminum fins while cleaning. CAUTION: Fin edges are sharp.

Cabinet

Do not allow water to stay in contact with the cabinet for long periods of time to prevent corrosion of the cabinet sheet metal. Generally, vertical cabinets are set up from the floor a few inches [7 - 8 cm] to prevent water from entering the cabinet. The cabinet can be cleaned using a mild detergent.

Refrigerant System

To maintain sealed circuit integrity, do not install service gauges unless unit operation appears abnormal. Reference the operating charts for pressures and temperatures. Verify that air and water flow rates are at proper levels before servicing the refrigerant circuit.

Functional Troubleshooting

Fault	Htg	Clg	Possible Cause	Solution
Main power Problems	X	X	Green Status LED Off	Check Line Voltage circuit breaker and disconnect Check for line voltage between L1 and L2 on the contactor Check for 24VAC between R and C on CXM Check primary/secondary voltage on transformer
	HP Fault-Code 2 High pressure	X	Reduced or no water flow in cooling	Check pump operation or valve operation/setting Check water flow adjust to proper flow rate
		X	Water Temperature out of range in cooling	Bring water temp within design parameters
		X	Reduced or no Air flow in heating	Check for dirty air filter and clean or replace Check fan motor operation and airflow restrictions Dirty Air Coil- construction dust etc. Too high of external static. Check static vs blower table
X		Air Temperature out of range in heating	Bring return air temp within design parameters	
X		X	Overcharged with refrigerant	Check superheat/subcooling vs typical operating condition table
X		X	Bad HP Switch	Check switch continuity and operation. Replace
LP/LOC Fault-Code 3 Low Pressure/Loss of Charge	X	X	Insufficient charge	Check for refrigerant leaks
	X		Compressor pump down at start-up	Check charge and start-up water flow
FP1 Fault - Code 4 Water Coil low temperature limit	X		Reduced or no water flow in heating	Check pump operation or water valve operation/setting Plugged strainer or filter. Clean or replace. Check water flow adjust to proper flow rate
	X		Inadequate anti-freeze level	Check antifreeze density with hydrometer
	X		Improper temperature limit setting (30°F vs 10°F [-1°C vs -12°C])	Clip JW3 jumper for antifreeze (10°F [-12°C]) use
	X		Water Temperature out of range	Bring water temp within design parameters
	X	X	Bad thermistor	Check temp and impedance correlation per chart
FP2 fault - Code 5 Air Coil low temperature limit	X	X	Reduced or no Air flow in cooling	Check for dirty air filter and clean or replace Check fan motor operation and airflow restrictions Too high of external static. Check static vs blower table
	X		Air Temperature out of range	Too much cold vent air? Bring entering air temp within design parameters
	X		Improper temperature limit setting (30°F vs 10°F [-1°C vs -12°C])	Normal airside applications will require 30°F [-1°C] only
	X	X	Bad thermistor	Check temp and impedance correlation per chart
Condensate Fault-Code 6	X	X	Blocked Drain	Check for blockage and clean drain
	X	X	Improper trap	Check trap dimensions and location ahead of vent
	X		Poor Drainage	Check for piping slope away from unit Check slope of unit toward outlet Poor venting. Check vent location
	X		Moisture on sensor	Check for moisture shorting to air coil
Over/Under Voltage-Code 7 (Auto resetting)	X	X	Under Voltage	Check power supply and 24VAC voltage before and during operation. Check power supply wire size Check compressor starting. Need hard start kit? Check 24VAC and unit transformer tap for correct power supply voltage
	X	X	Over Voltage	Check power supply voltage and 24VAC before and during operation. Check 24VAC and unit transformer tap for correct power supply voltage
Unit Performance Sentinel-Code 8	X		Heating mode FP2>125°F [52°C]	Check for poor air flow or overcharged unit.
	X		Cooling Mode FP1>125°F [52°C] OR FP2< 40°F [4°C]	Check for poor water flow, or air flow
No Fault Code Shown	X	X	No compressor operation	See "Only fan operates"
	X	X	Compressor Overload	Check and Replace if necessary
	X	X	Control board	Reset power and check operation
Unit Short Cycles	X	X	Dirty Air Filter	Check and Clean air filter
	X	X	Unit in "Test Mode"	Reset power or wait 20 minutes for auto exit.
	X	X	Unit selection	Unit may be oversized for space. Check sizing for actual load of space.
	X	X	Compressor Overload	Check and Replace if necessary
Only Fan Runs	X	X	Thermostat position	Insure thermostat set for heating or cooling operation
	X	X	Unit locked out	Check for lockout codes. Reset power.
	X	X	Compressor Overload	Check compressor overload. Replace if necessary.
	X	X	Thermostat wiring	Check thermostat wiring at heat pump. Jumper Y and R for compressor operation in test mode.

Functional Troubleshooting

Only Compressor Runs	X	X	Thermostat wiring	Check G wiring at heat pump. Jumper G and R for fan operation.
	X	X	Fan motor relay	Jumper G and R for fan operation. Check for Line voltage across BR contacts. Check fan power enable relay operation (if present)
	X	X	Fan motor	Check for line voltage at motor. Check capacitor
	X	X	Thermostat wiring	Check thermostat wiring at heat pump. Jumper Y and R for compressor operation in test mode.
Unit Doesn't Operate in Cooling		X	Reversing Valve	Set for cooling demand and check 24VAC on RV coil and at CXM/DXM board. If RV is stuck, run high pressure up by reducing water flow and while operating engage and disengage RV coil voltage to push valve.
		X	Thermostat setup	Check for 'O' RV setup not 'B'
		X	Thermostat wiring	Check O wiring at heat pump. Jumper O and R for RV coil 'Click'.
		X	Thermostat wiring	Put thermostat in cooling mode. Check for 24VAC on O (check between C and O); check for 24VAC on W (check between W and C). There should be voltage on O, but not on W. If voltage is present on W, thermostat may be bad or wired incorrectly.

Performance Troubleshooting

Performance Troubleshooting	Htg	Clg	Possible Cause	Solution
Insufficient capacity/ Not cooling or heating properly	X	X	Dirty Filter	Replace or clean
	X		Reduced or no Air flow in heating	Check for dirty air filter and clean or replace Check fan motor operation and airflow restrictions Too high of external static. Check static vs blower table
		X	Reduced or no Air flow in cooling	Check for dirty air filter and clean or replace Check fan motor operation and airflow restrictions Too high of external static. Check static vs blower table
	X	X	Leaky duct work	Check supply and return air temperatures at the unit and at distant duct registers if significantly different, duct leaks are present
	X	X	Low refrigerant charge	Check superheat and subcooling per chart
	X	X	Restricted metering device	Check superheat and subcooling per chart. Replace.
		X	Defective Reversing Valve	Perform RV touch test
	X	X	Thermostat improperly located	Check location and for air drafts behind stat
	X	X	Unit undersized	Recheck loads & sizing check sensible clg load and heat pump capacity
	X	X	Scaling in water heat exchanger	Perform Scaling check and clean if necessary
	X	X	Inlet Water too Hot or Cold	Check load, loop sizing, loop backfill, ground moisture.
	High Head Pressure	X		Reduced or no Air flow in heating
		X	Reduced or no water flow in cooling	Check pump operation or valve operation/setting Check water flow adjust to proper flow rate
		X	Inlet Water too Hot	Check load, loop sizing, loop backfill, ground moisture.
X			Air Temperature out of range in heating	Bring return air temp within design parameters
		X	Scaling in water heat exchanger	Perform Scaling check and clean if necessary
X		X	Unit Overcharged	Check superheat and subcooling. Reweigh in charge
X		X	Non-condensables insystem	Vacuum system and reweigh in charge
X		X	Restricted metering device	Check superheat and subcooling per chart. Replace.
Low Suction Pressure	X		Reduced water flow in heating	Check pump operation or water valve operation/setting Plugged strainer or filter. Clean or replace. Check water flow adjust to proper flow rate
	X		Water Temperature out of range	Bring water temp within design parameters
		X	Reduced Air flow in cooling	Check for dirty air filter and clean or replace Check fan motor operation and airflow restrictions Too high of external static. Check static vs blower table
		X	Air Temperature out of range	Too much cold vent air? Bring entering air temp within design parameters
	X	X	Insufficient charge	Check for refrigerant leaks
Low discharge air temperature in heating	X		Too high of air flow	Check fan motor speed selection and airflow chart
	X		Poor Performance	See 'Insufficient Capacity'
High humidity		X	Too high of air flow	Check fan motor speed selection and airflow chart
		X	Unit oversized	Recheck loads & sizing check sensible clg load and heat pump capacity

Functional Troubleshooting - I.P. Units

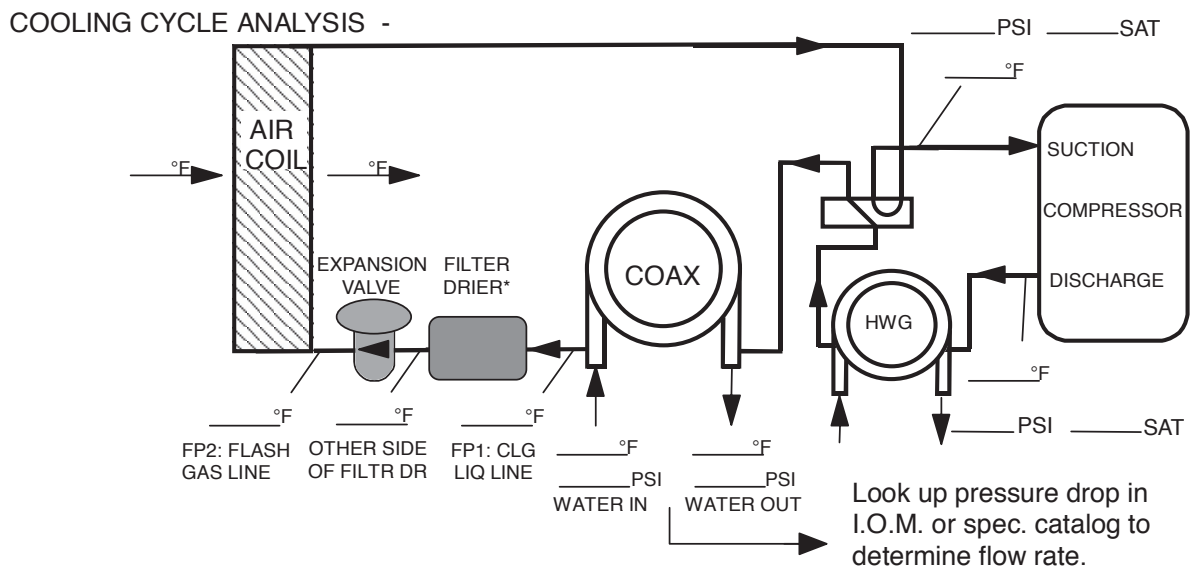
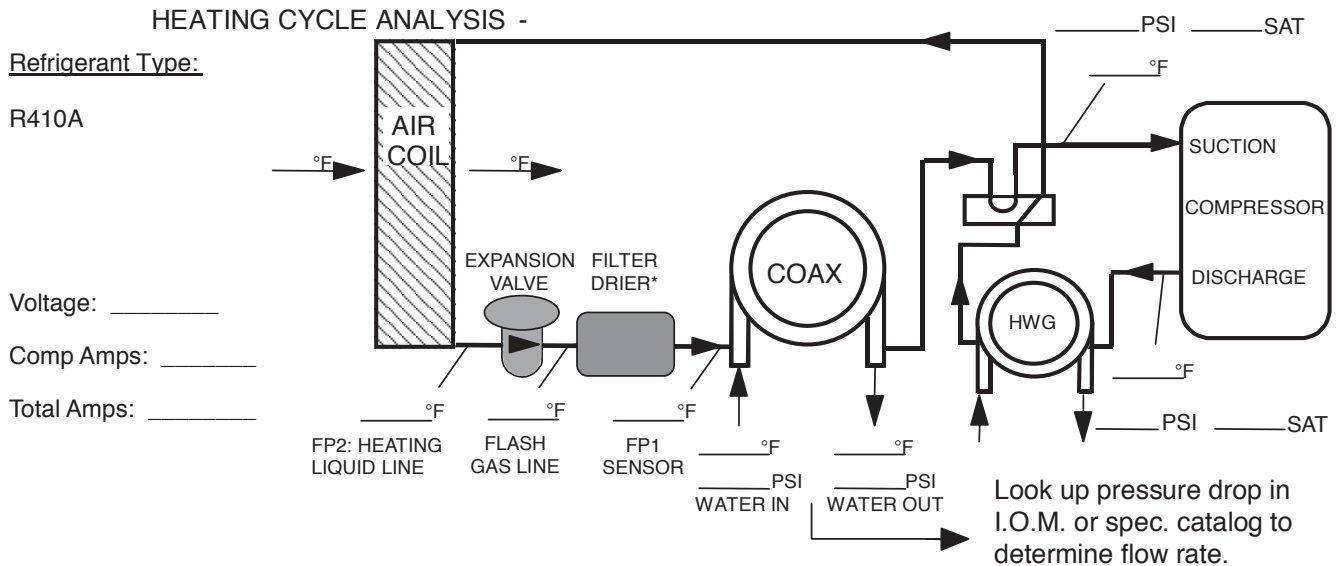

Heat of Extraction (Absorption) or Heat of Rejection = _____ flow rate (gpm) x _____ temp.diff. (deg. F) x _____ fluid factor[†] = _____ (Btu/hr)

Superheat = Suction temperature - suction saturation temp. = _____ (deg F)

Subcooling = Discharge saturation temp. - liquid line temp. = _____ (deg F)

[†] Use 500 for water, 485 for antifreeze.

Note: Never connect refrigerant gauges during startup procedures. Conduct water-side analysis using P/T ports to determine water flow and temperature difference. If water-side analysis shows poor performance, refrigerant troubleshooting may be required. Connect refrigerant gauges as a last resort.

Design, material, performance data and components
subject to change without notice.

HEAT CONTROLLER, INC.

1900 Wellworth Ave., Jackson, MI 49203 ♦ Ph. 517-787-2100 ♦ Fax 517-787-9341

THE QUALITY LEADER IN CONDITIONING AIR

www.heatcontroller.com