

EC Large Series

072, 096, 120, 150, 151, 180, 181, 210, 240, 242, 300, 360.



BOSCH
FP

Installation, operation and Maintenance Manual

CONTENTS

Model Nomenclature.....	3	Unit Nameplate Data.....	24
Initial Inspection.....	4	Operating Conditions.....	24
General Description.....	4	Auxiliary Heat	24
Moving and Storage	5	troubleshooting	25
Location.....	5	Belt drive Motor	
INSTALLATION	5	Table.....	28
MOUNTING VERTICALLY.....	5	Blower Performance	
MOUNTING HORIZONTALLY.....	5	Table.....	29
CONDENSATE DRAIN	6	Water side Pressure Drop	
Duct System.....	6	Table.....	30
Piping	7	Operating temperatures and Pressures.....	31
Electrical	7	Wiring diagrams.....	34
ECM INTERFACE BOARD.....	8	Notes	46
Thermostat Connections	9		
Safety Devices and the UPM Controller	10		
Electronic Thermostat Installation.....	13		
Water Quality.....	15		
UPM Sequence of Operation.....	14		
Water Quality table.....	15		
Heat Recovery Package	16		
Typical Connection Piping (HRP).....	16		
Water Tank PreCaration:.....	16		
HR Water Piping	16		
Water Tank Refill	17		
Initial Start-Up.....	17		
Hot Gas Reheat (HGRH)	17		
Sequence of Operation	18		
Cooling Mode	18		
Heating Mode.....	18		
Application considerations.....	18		
Well Water Systems	18		
Installation of Pressure Regulating Valves.....	19		
Cooling Tower/Boiler Systems.....	19		
Geothermal (Earth-Coupled) Systems	21		
System Checkout.....	22		
Unit Start-up	22		
Maintenance	23		
Unit Check-Out Sheet	24		
Customer Data	24		

Key to symbols and safety instructions

Key to symbols

Warnings



Warnings in this document are identified by a warning triangle printed against a grey background. Keywords at the start of a warning indicate the type and seriousness of the ensuing risk if measures to prevent the risks are not taken.

The following keywords are defined and can be used in this document:

- **NOTE** indicates a situation that could result in damage to property or equipment.
- **CAUTION** indicates a situation that could result in minor to medium injury.
- **WARNING** indicates a situation that could result in severe injury or death.
- **DANGER** indicates a situation that will result in severe injury or death.

MODEL NOMENCLATURE

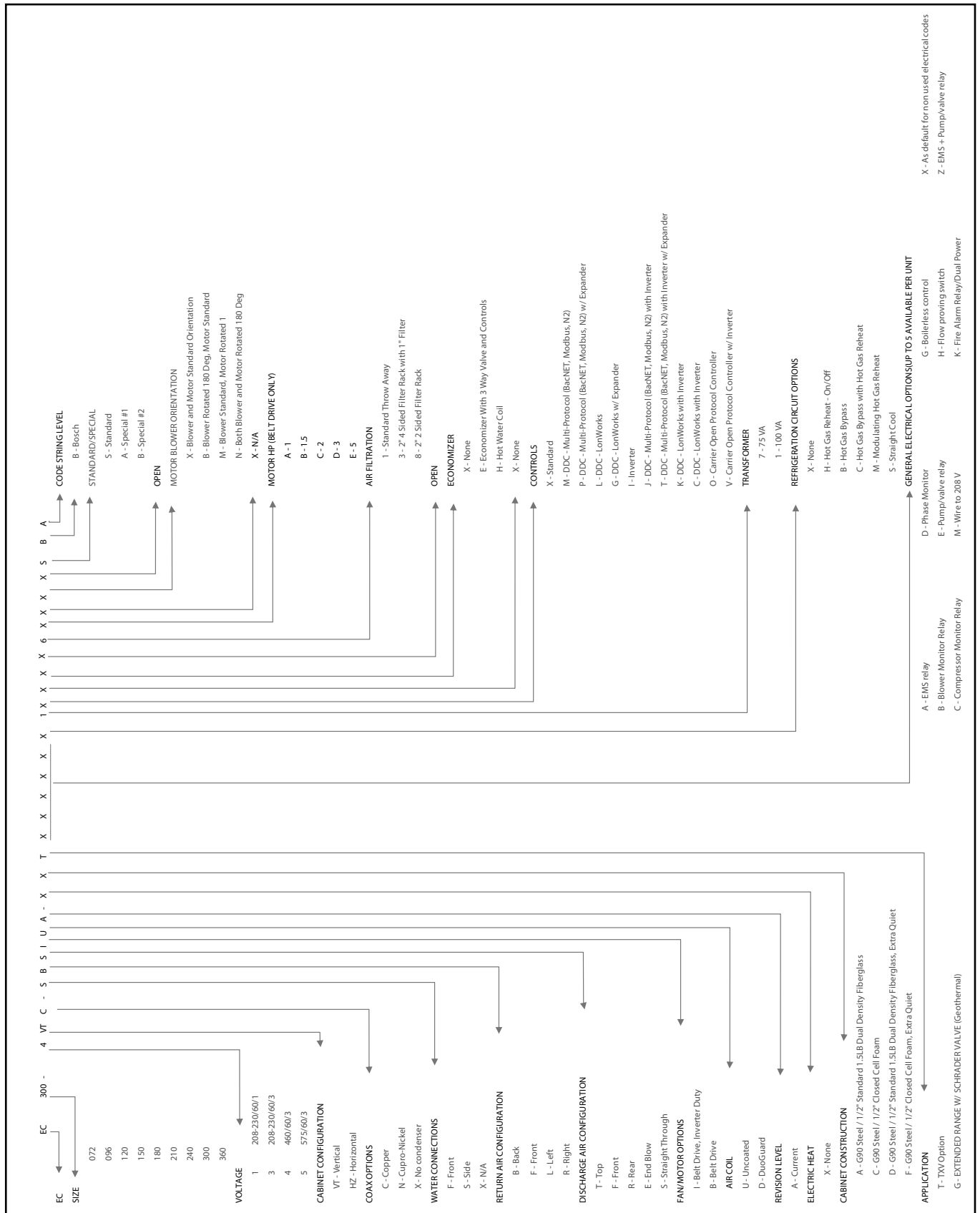

Figure # 1



WARNING: Installation and servicing of this equipment can be hazardous due to system pressure and electrical components. Only trained and qualified personnel should install, rECair, or service the equipment.



WARNING: Before performing service or maintenance operations on the system, turn off main power to the unit. Electrical shock could cause personal injury or death.



CAUTION: When working on equipment, always observe precautions described in the literature, tags, and labels attached to the unit. Follow all safety codes. Wear safety glasses and work gloves. Use a quenching cloth for brazing, and place a fire extinguisher close to the work area.



NOTE: All refrigerant discharged from this unit must be recovered WITHOUT EXCEPTION. Technicians must follow industry accECted guidelines and all local, state, and federal statutes for the recovery and disposal of refrigerants. If a compressor is removed from this unit, refrigerant circuit oil will remain in the compressor. To avoid leakage of compressor oil, refrigerant lines of the compressor must be sealed after it is removed.



NOTE: To avoid equipment damage, DO NOT use these units as a source of heating or cooling during the construction process. Doing so may affect the unit's warranty. The mechanical components and filters will quickly become clogged with construction dirt and debris, which may cause system damage.



NOTE: To avoid the release of refrigerant into the atmosphere, the refrigerant circuit of this unit must be serviced only by technicians who meet local, state, and federal proficiency requirements.

INITIAL INSPECTION

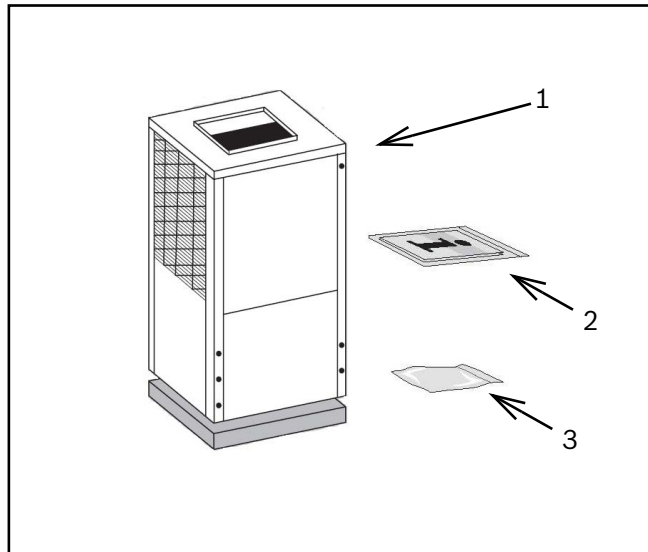

Figure # 2

- [1] EC Series Water-to-Air Heat Pump
- [2] Installation and Operation Manual
- [3] Hanging Bracket kit (HZ unit only)

Be certain to inspect all cartons or crates on each unit as received at the job site before signing the freight bill. Verify that all items have been received and that there are no visible damages; note any shortages or damages on all copies of the freight bill. In the event of damage or shortage, remember that the purchaser is responsible for filing the necessary claims with the carrier. Concealed damages not discovered until after removing the units from the packaging must be rECorted to the carrier within 24 hours of receipt.

GENERAL DESCRIPTION

EC Series Water-to-Air Heat Pumps provide the best combination of performance and efficiency available. Safety devices are built into each unit to provide the maximum system protection possible when properly installed and maintained.

All EC water to Air Heat Pumps conform to UL1995 standard and are certified to CAN/CSA C22.2 No 236 by Intertek-ETL. The Water-to-Air Heat Pumps are designed to operate with entering fluid temperature between 20°F to 90°F in the heating mode and between 30°F to 120°F in the cooling mode.



NOTE: 50° Minimum Entering Water Temperature (EWT) for well water applications with sufficient water flow to prevent freezing. Antifreeze solution is required for all closed loop applications. Cooling Tower/Boiler and Geothermal applications should have sufficient antifreeze solution to protect against extreme conditions and equipment failure. Frozen water coils are not covered under warranty.



NOTE: This product should not be used for temporarily heating/cooling during construction. Doing so may affect the unit's warranty.

MOVING AND STORAGE

If the equipment is not needed for immediate installation upon its arrival at the job site, it should be left in its shipping carton and stored in a clean, dry area. Units must only be stored or moved in the normal upright position as indicated by the "UP" arrows on each carton at all times.



For storage If unit stacking is required, stack units as follows:

Do not stack units larger than 6 tons.

Vertical units less than 6 tons, no more than two high.

Horizontal units less than 6 tons, no more than three high.

LOCATION

Locate the unit in an indoor area that allows easy removal of the filter and access panels, and has enough room for service personnel to perform maintenance or repair. Provide sufficient room to make fluid, electrical, and duct connection(s). If the unit is located in a confined space such as a closet, provisions must be made for return air to freely enter the face of unit's air coil. On horizontal units, allow adequate room below the unit for a condensate drain trap and do not locate the unit above supply piping.



NOTE: These units are not approved for outdoor installation; therefore, they must be installed inside the structure being conditioned. Do not locate in areas that are subject to freezing.

INSTALLATION

MOUNTING VERTICALLY

Vertical units up to six tons are available in left or right air return configurations. Vertical units should be mounted level on a vibration absorbing pad slightly larger than the base to minimize vibration transmission to the building structure. It is not necessary to anchor the unit to the floor. (See Figure #3).

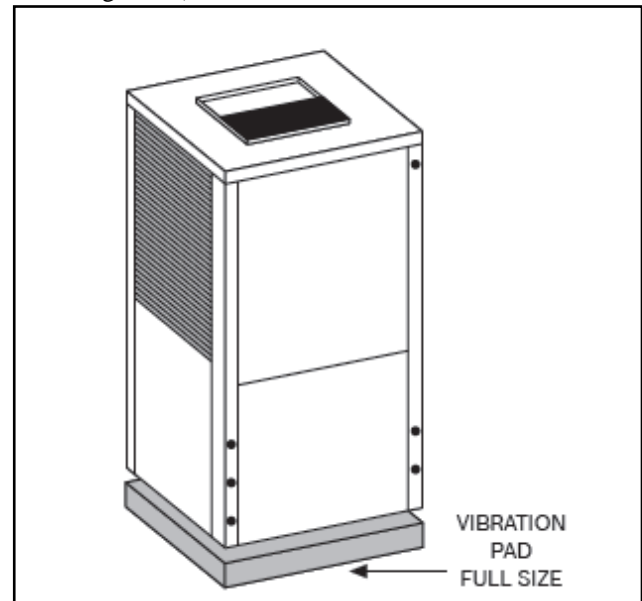

Figure # 3

MOUNTING HORIZONTALLY

While horizontal units may be installed on any level surface strong enough to hold their weight, they are typically suspended above a ceiling by threaded rods. The rods are usually attached to the unit corners by the base frame support rails, with mounting holes present (See Figure #4). The rods must be securely anchored to the ceiling. Horizontal units installed above the ceiling must conform to all local codes. An auxiliary drain pan if required by code, should be at least four inches larger than the bottom of the heat pump. Plumbing connected to the heat pump must not come in direct contact with joists, trusses, walls, etc. some applications require an attic floor installation of the horizontal unit. In this case the unit should be set in a full size secondary drain pan on top of a vibration absorbing mesh. The secondary drain pan prevents possible condensate overflow or water leakage damage to the ceiling. The secondary drain pan is usually placed on a plywood base isolated from the ceiling joists by additional layers of vibration absorbing mesh. In both cases, a 3/4" drain connected to this secondary pan should be run to an eaves at a location that will be noticeable.



NOTE: IF unit is located in a crawl space, the bottom of the unit **MUST** be at least 4" above grade to prevent flooding of the electrical parts due to heavy rains.

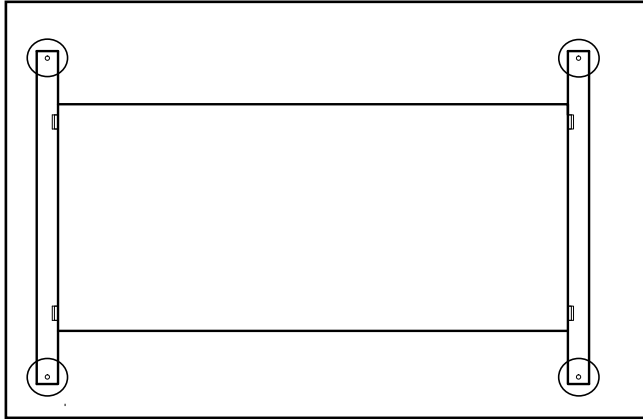

Figure # 4



NOTE: Plumbing connected to the heat pump must not come in direct contact with joists, trusses, walls, etc.

CONDENSATE DRAIN



If equipped with float style condensate overflow switch, final adjustment must be made in the field.

A drain line must be connected to the heat pump and pitched away from the unit a minimum of 1/8" per foot to allow the condensate to flow away from the unit.

This connection must be in conformance with local plumbing codes. A trap must be installed in the condensate line to insure free condensate flow. (Heat Pumps are not internally trapped).

A vertical air vent is sometimes required to avoid air pockets. (See Figure #5).

The length of the trap depends on the amount of positive or negative pressure on the drain pan. A second trap must not be included.

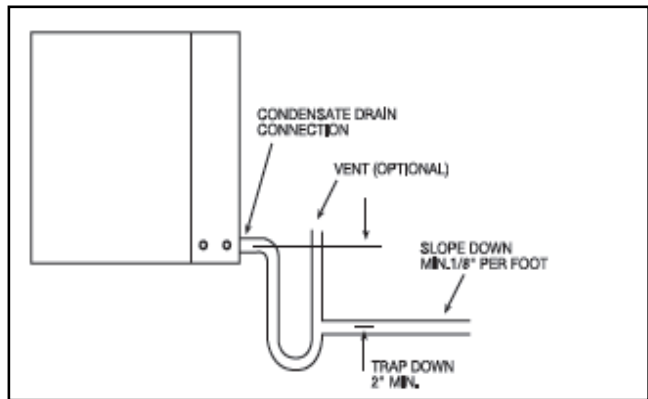

Figure # 5

The horizontal unit should be pitched approximately 1/4" towards the drain in both directions, to facilitate condensate removal. (See Figure #6)

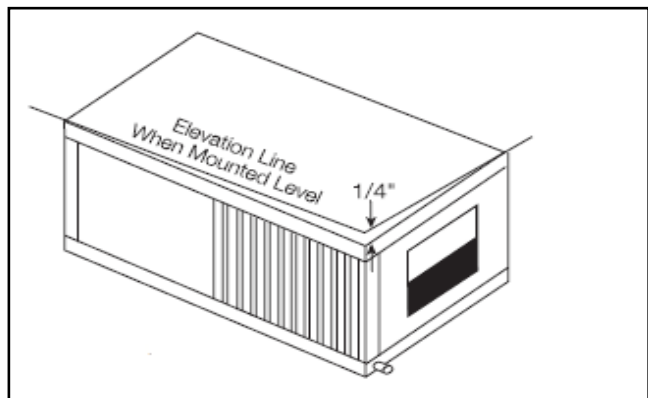

Figure # 6

DUCT SYSTEM



Supply air duct and return air duct flanges are shipped unfolded with unit.

A supply air outlet collar and return air duct flange are provided on all units to facilitate duct connections. Fold the duct flange outwards along the perforated line. Refer to unit Dimensional Drawings for physical dimensions of the collar and flange. (Pg#33 through Pg#34)

A flexible connector is recommended for supply and return air duct connections on metal duct systems. All metal ducting should be insulated with a minimum of one inch duct insulation to avoid heat loss or gain and prevent condensate forming during the cooling operation.



NOTE: Application of the unit to no insulated duct work is not recommended as the unit's performance will be adversely affected.



NOTE: The factory provided air filter must be removed when using a filter back return air grill. The factory filter should be left in place on a free return system



NOTE: Do not connect discharge ducts directly to the blower outlet.

If the unit will be installed in a new installation which includes new duct work, the installation should be designed using current ASHRAE procedures for duct sizing.

If the unit is to be connected to existing duct work, a check should be made to assure that the duct system has the capacity to handle the air required for the unit application. If the duct system is too small, larger duct work should be installed. Check for existing leaks and repair.

The duct system and all diffusers should be sized to handle the designed air flow quietly. To maximize sound attenuation of the unit blower, the supply and return air plenums should be insulated. There should be no direct straight air path thru the return air grille into the heat pump.

The return air inlet to the heat pump must have at least one 90 degree turn away from the space return air grille.

If air noise or excessive air flow are a problem, the blower speed can be changed to a lower speed to reduce air flow.

(Refer to ECM motor interface board section in Figure#11)

PIPING

Supply and return piping must be as large as the unit connections on the heat pump (larger on long runs).



NOTE: Never use flexible hoses of a smaller inside diameter than that of the fluid connections on the unit.

EC units are supplied with either a copper or optional cupro-nickel condenser. Copper is adequate for ground water that is not high in mineral content.



NOTE: Proper testing is recommended to assure the well water quality is suitable for use with water source equipment.

In conditions anticipating moderate scale formation or in brackish water a cupro-nickel heat exchanger is recommended.



NOTE: Both the supply and discharge water lines will sweat if subjected to low water temperature. These lines should be insulated to prevent damage from condensation.

All manual flow valves used in the system must be ball valves. Globe and gate valves must not be used due to high pressure drop and poor throttling characteristics.



NOTE: Never exceed the recommended water flow rates as serious damage or erosion of the water-to-refrigerant heat exchanger could occur.

Always check carefully for water leaks and rECair appropriately. Units are equipped with female pipe thread fittings. Consult Unit Dimensional Drawings. (Pg#33 through Pg#34)



NOTE: Teflon tape sealer should be used when connecting water piping connections to the units to insure against leaks and possible heat exchanger fouling.



NOTE: Do not overtighten the connections.

Flexible hoses should be used between the unit and the rigid system to avoid possible vibration. Ball valves should be installed in the supply and return lines for unit isolation and unit water flow balancing.

ELECTRICAL

Refer to electrical component box layout. (Figure#10)



WARNING: Field wiring must comply with local and national electric codes.

WARNING: Power to the unit must be within the operating voltage range indicated on the unit nameplate or on the performance data sheet.

WARNING: Operation of unit on improper line voltage or with excessive phase imbalance will be hazardous to the unit, constitutes abuse and may void the warranty.

Properly sized fuses or HACR circuit breakers must be installed for branch circuit protection. See unit nameplate for maximum fuse or breaker size.

The unit is provided with a concentric knock-out for attaching common trade sizes of conduit, route power supply wiring through this opening. Always connect the ground lead to the grounding lug provided in the control box and power leads to the line side of compressor contactor as indicated on the wiring diagrams..

NOTE: Units supplied with internal electric heat require two (2) separate power supplies:

- 1) Unit compressor
- 2) Electric Heat, blower motor and control circuit.

NOTE: Refer to the ELECTRIC HEATER PACKAGE OPTION section and Figure # 11 for wiring diagrams. See data plate for minimum circuit ampacities and maximum fuse/breaker sizing.

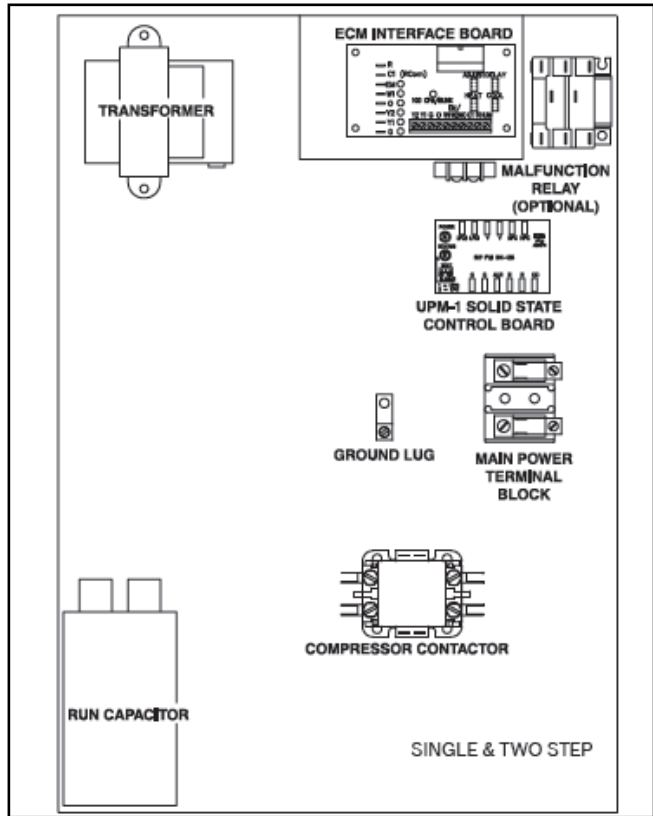

Figure # 7

ECM INTERFACE BOARD

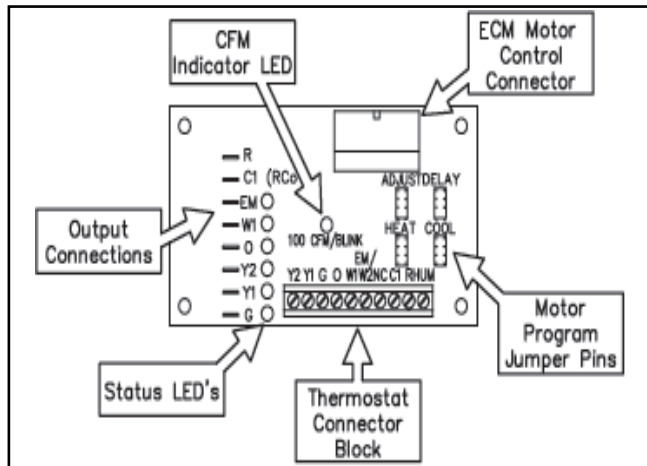

Figure # 8

THERMOSTAT CONNECTIONS

Thermostat wiring is connected to the 10 pin screw type terminal block on the lower center portion of the ECM Interface Board. In addition to providing a connecting point for thermostat wiring, the interface board also translates thermostat inputs into control commands for the Electronic Commutated Motor (ECM) DC fan motor and displays an LED indication of operating status. The thermostat connections and their functions are as follows:

Y1	First Stage Compressor Operation
Y2	Second Stage Compressor Operation
G	Fan
O	Reversing Valve (energized in cooling)
W1	Auxiliary Electric Heat (runs in conjunction with compressor)
EM/W2	Emergency Heat (electric heat only)
NC	Transformer 24 VAC Common (extra connection)
C1	Transformer 24 VAC Common (primary connection)
R	Transformer 24 VAC Hot
HUM	Dehumidification Mode (not used in EC Series)

If the unit is being connected to a thermostat with a malfunction light, this connection is made at the unit malfunction output or relay.



If the thermostat is provided with a malfunction light powered off of the common (C) side of the transformer, a jumper between “R” and “COM” terminal of the “ALR” contacts must be made.



If the thermostat is provided with a malfunction light powered off of the hot (R) side of the transformer, then the thermostat malfunction light should be connected directly to the (ALR) contact on the unit’s UPM board.

To the left of the thermostat connection block are a row of 2 red and 4 green LED’s. These LED’s indicate the operating status of the unit. They are labeled as follows:

EM (Red)	Emergency Heat On
W1 (Red)	Auxiliary Heat On
O (Green)	Reversing Valve Energized, unit is in Cooling Mode
Y2 (Green)	Second Stage Compressor On
Y1 (Green)	First Stage Compressor On
G (Green)	Fan On



Just above the connector block is a single red LED labeled CFM that will blink intermittently when the unit is running and may flicker when the unit is off.

This LED indicates the air delivery of the blower at any given time. Each blink of the LED represent approximately 100 CFM of air delivery so if the LED blinks 12 times, pauses, blinks 12 times, etc. the blower is delivering approximately 1200 CFM. for factory programmed air delivery settings for the EC Series.

To the right of the thermostat connection block is a green LED labeled dehumidify.

Just above and to the right of the thermostat connection block are four sets of jumper pins labeled ADJ, DELAY, HEAT and COOL. The ADJ set of pins are labeled NORM, (+), (-) and TEST. EC units will all be set on the NORM position from the factory, however, airflow can be increased (+) or decreased (-) by 15% from the pre-programmed setting by relocating the jumper in this section.

The TEST position is used to verify proper motor operation. If a motor problem is suspected, move the ADJ jumper to the TEST position and energize G on the thermostat connection block. If the motor ramps up to 100% power, then the motor itself is functioning normally. Always remember to rEClace the jumper to NORM, (+) or (-) after testing and reset the unit thermostat to restore normal operation.



NOTE: Do not set the ADJ DIP switch to the (-) setting when electric heaters are installed. Doing so may cause the heaters to cycle on their thermal overload switches, potentially shortening the life of the switches.

The other DIP switch bank is used to select the proper program in the ECM motor for the unit. Refer to Figure #7 for the proper jumper placement.



WARNING: Always disconnect power before changing jumper positions on the interface board and reset the unit afterward.



WARNING: Remember to always turn off unit power at the circuit breaker before attaching or disconnecting any wiring from these connections to avoid accidental short circuits that can damage unit control components.

To the left of the red and green status LED's is a row of 1/4" male quick connects. These are used to pass thermostat inputs on to the rest of the control circuit.

SAFETY DEVICES AND THE UPM CONTROLLER

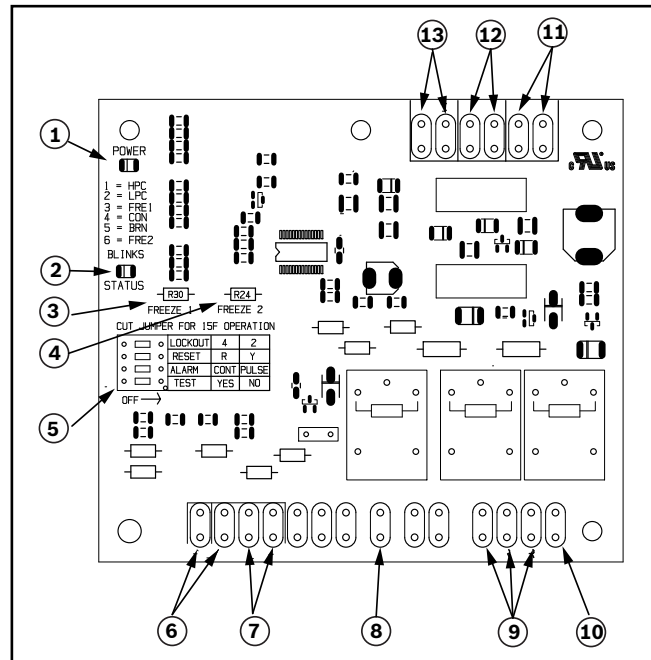

Figure # 9

- [1] Board power indicator
- [2] UPM Board LED indicator
- [3] Water coil freeze protection temperature selection (FREEZE1)
- [4] Air coil freeze protection temperature selection (FREEZE 2)
- [5] UPM board settings
- [6] Water coil freeze connection
- [7] Air coil freeze connection
- [8] LCD connection
- [9] 24VAC power hot
- [10] To compressor contactor
- [11] High pressure switch connection
- [12] Call for compressor
- [13] Low pressure switch connection
- [14] 24VAC power common



NOTE: If the unit is being connected to a thermostat with a malfunction light, this connection is made at the unit malfunction output or relay.

Each unit is factory provided with a Unit Protection Module (UPM) that controls the compressor operation and monitors the safety controls that protect the unit.

Safety controls include the following:

- High pressure switch located in the refrigerant discharge line and wired across the HPC terminals on the UPM
- Low pressure switch located in the unit refrigerant suction line and wired across terminals LPC1 and LPC2 on the UPM.



UPM Board Dry Contacts are Normally Open (NO)

- Water side freeze protection sensor, mounted close to condensing water coil, monitors refrigerant temperature between condensing water coil and thermal expansion valve. If temperature drops below or remains at freeze limit trip for 30 seconds, the controller will shut down the compressor and enter into a soft lockout condition. The default freeze limit trip is 26°F, however this can be changed to 15°F by cutting the R42 resistor located on top of DIP switch SW1. (Figure #13)

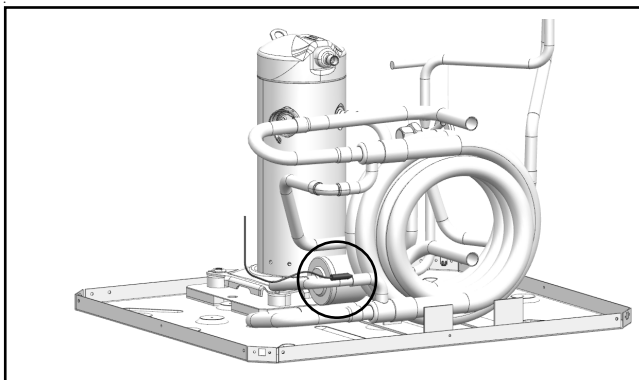

Figure # 10

- The optional condensate overflow protection sensor (standard on horizontal units) is located in the drain pan of the unit and connected to the 'COND' terminal on the UPM board. (Figure #14)

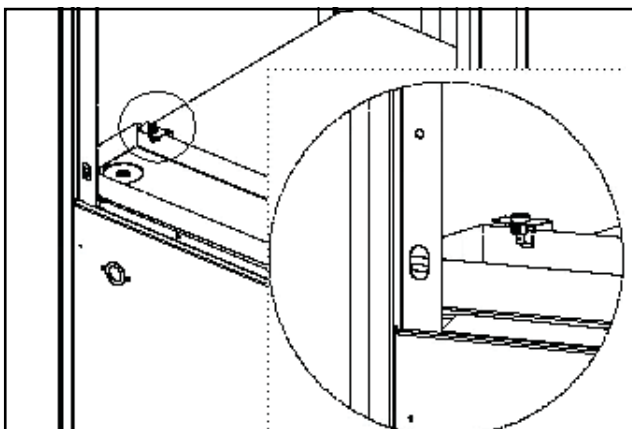

Figure # 11

UPM Board Factory Default Settings

TEMP	26°F
LOCKOUT	2
RESET	Y
ALARM	PULSE
TEST	NO
HOT/DRY ALARM	NO

UPM DIP SWITCH DEFAULT POSITION

	lockout	4	2
	reset	R	Y
	alarm	Cont	pulse
	test	yes	no

The UPM Board includes the following features:

- **ANTI-SHORT CYCLE TIMER:** 5 minute delay on break timer to prevent compressor short cycling.
- **RANDOM START:** Each controller has an unique random start delay ranging from 270 to 300 seconds on initial power up to reduce the chance of multiple unit simultaneously starting at the same time after power up or after a power interruption, thus avoiding creating large electrical spike.
- **LOW PRESSURE BYPASS TIMER:** If the compressor is running and the low pressure switch opens, the controller will keep the compressor ON for 120 seconds. After 2 minutes if the low pressure switch remains open, the controllers will shut down the compressor and enter a soft lockout. The compressor will not be energized until the low pressure switch closes and the anti-short cycle time delay expires. If the low pressure switch opens 2-4 times in 1 hour, the unit will enter a hard lockout. In order to exit hard lockout, power to the unit would need to be reset.
- **BROWNOUT/SURGE/POWER INTERRUPTION PROTECTION:** The brownout protection in the UPM board will shut down the compressor if the incoming power falls below 18 VAC. The compressor will remain OFF until the voltage is above 18 VAC and ANTI-SHORT CYCLE TIMER (300 seconds) times out. The unit will not go into a hard lockout and does not need to be reset.

- **MALFUNCTION OUTPUT:** Alarm output is Normally Open (NO) dry contact. If pulse is selected the alarm output will be pulsed. The fault output will depend on the dip switch setting for "ALARM". If it is set to "CONST", a constant signal will be produced to indicate a fault has occurred and the unit requires inspection to determine the type of fault. If it is set to "PULSE", a pulse signal is produced and a fault code is detected by a remote device indicating the fault. See L.E.D Fault Indication below for blink code explanation. The remote device must have a malfunction detection capability when the UPM board is set to "PULSE".



If 24 VAC output is needed R must be wired to ALR-COM terminal; 24 VAC will be available on the ALR-OUT terminal when the unit is in the alarm condition.

- **DISPLAY OUTPUT:** The Display output is a pulse output connected to the Unit Diagnostic Display (UDD) and it pulses 24VAC when the unit is in a lockout alarm condition.
- **TEST DIP SWITCH:** A test dip switch is provided to reduce all time delays settings to 10 seconds during troubleshooting or verification of unit operation.



NOTE: Operation of unit in test mode can lead to accelerated wear and premature failure of components. The "TEST" switch must be set back to "NO" after troubleshooting/servicing.

- **FREEZE SENSOR:** The freeze sensor input is active all the time, if a freeze option is not selected the freeze terminals will need a jumper. There are two (2) configurable freeze points, 26°F & 15°F. The unit will enter a soft lock out until the temperature climbs above the set point and the anti-short cycle time delay has expired. The freeze sensor will shut the compressor output down after 90 seconds of water flow loss and report a freeze condition.



It is recommended to have a flow switch to prevent the unit from running if water flow is lost.



NOTE: If unit is employing a fresh water system (no anti-freeze protection), it is extremely important to have the Freeze1 R42 resistor set to 26°F in order to shut down the unit at the appropriate leaving water temperature and protect your heat pump from freezing if a freeze sensor is included.

- **L.E.D. FAULT INDICATION:** Two L.E.D. indicators are provided:
Green: Power L.E.D. indicates 18-30 VAC present on board.
Red: Fault indicator with the following blink codes;
 1 - High Pressure Lockout
 2 - Low Pressure Lockout
 3 - Freeze Sensor Lockout
 4 - Condensate Overflow
 5 - Brownout
- **INTELLIGENT RESET:** If a fault condition is initiated, the 5 minute delay on break time period is initiated and the unit will restart after these delays expire. During this period the fault LED will indicate the cause of the fault. If the fault condition still exists or occurs 2 or 4 times (depending on 2 or 4 setting for Lockout dip switch) before 60 minutes, the unit will go into a hard lockout and requires a manual lockout reset. A single condensate overflow fault will cause the unit to go into a hard lockout immediately, and will require a manual lockout reset.
- **LOCKOUT RESET:** A hard lockout can be reset by turning the unit thermostat off and then back on when the "RESET" dip switch is set to "Y" or by shutting off unit power at the circuit breaker when the "RESET" dip switch is set to "R".



The blower motor will remain active during a lockout condition.



NOTE: Always check incoming line voltage power supply and secondary control voltage for adequacy

ELECTRONIC THERMOSTAT INSTALLATION

Position the thermostat subbase against the wall so that it is level and the thermostat wires protrude through the middle of the subbase. Mark the position of the subbase mounting holes and drill holes with a 3/16-inch bit. Install supplied anchors and secure base to the wall. Thermostat wire must be 8-conductor, 18-AWG wire. Strip the wires back 1/4-inch (longer strip lengths may cause shorts) and insert the thermostat wires into the connector as shown. Tighten the screws to ensure secure connections. The thermostat has the same type connectors, requiring the same wiring. See instructions in the thermostat for detailed installation and operation information

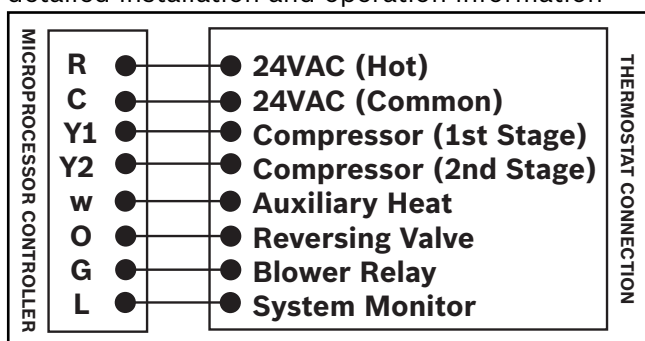

Figure # 12 Thermostat Wiring



NOTE: When using a 2-cool, 3-heat thermostat W1 and W2/EM must be connected together via a jumper. (Figure#16)

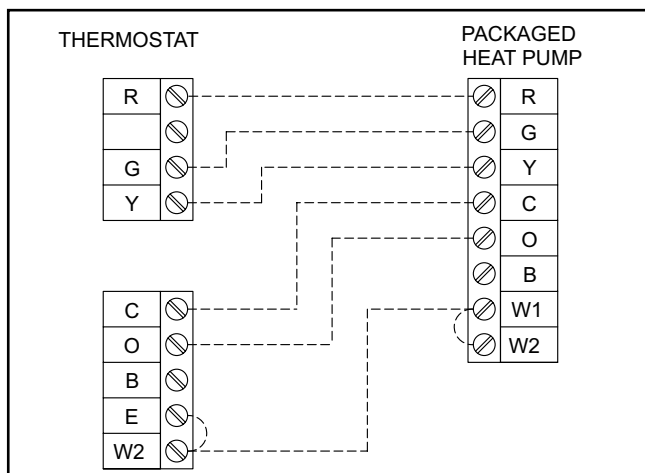

Figure # 13

WATER QUALITY



NOTE: Failure to insure proper water quality and flow rates can shorten the life of the heat pump and potentially void the unit warranty.

Maintaining proper water quality is important for insuring a long and trouble free service life for an LV series heat pump.

For closed loop and boiler/tower systems water chemistry can be checked and easily maintained to insure that corrosive elements, dissolved oxygen and pH levels are kept in check. It is important to insure that any additive, antifreeze or corrosion inhibitor that is added to the water loop is compliant with all applicable laws and regulations and is compatible with copper, brass and bronze alloys. Insure that all recommended safety precautions are followed when handling or adding chemicals to the water loop.

For open loop systems, water quality is very important. Refer to Quality Table on page# 6 shows acceptable ranges for a variety of water quality factors. The three main concerns in open loop installations are scaling, corrosion and fouling.

In installations with hard water, scaling due to a buildup of carbonates on the heat exchanger wall can gradually degrade the heat pump performance over time. Heat pumps that are affected by scaling may exhibit low suction pressures in heating and high head pressures in cooling with a gradual loss of capacity and efficiency. Scaled heat exchangers can be cleaned by a qualified technician but care should be taken to avoid scaling in the first place.

To limit scaling, water flow rates should be kept at 3 gallons/minute per nominal cooling ton (a 10°F temperature rise in cooling) and care should be taken to avoid air in the water lines from suction side leaks. Cupro-nickel coils are generally recommended.

In installations with high hydrogen sulfide, chlorine or ammonia, corrosion is a potential problem. In these installations a cupro-nickel heat exchanger is recommended along with maintaining proper flow and keeping air out of the system. If water quality is outside of the values in water quality table, then a closed loop is recommended.

Fouling due to iron bacteria can also pose problems in some open loop installations. Iron bacteria fouling can quickly degrade system performance and plug heat exchangers.

Air in the water system will greatly accelerate the fouling or corrosion process.

UPM SEQUENCE OF OPERATION

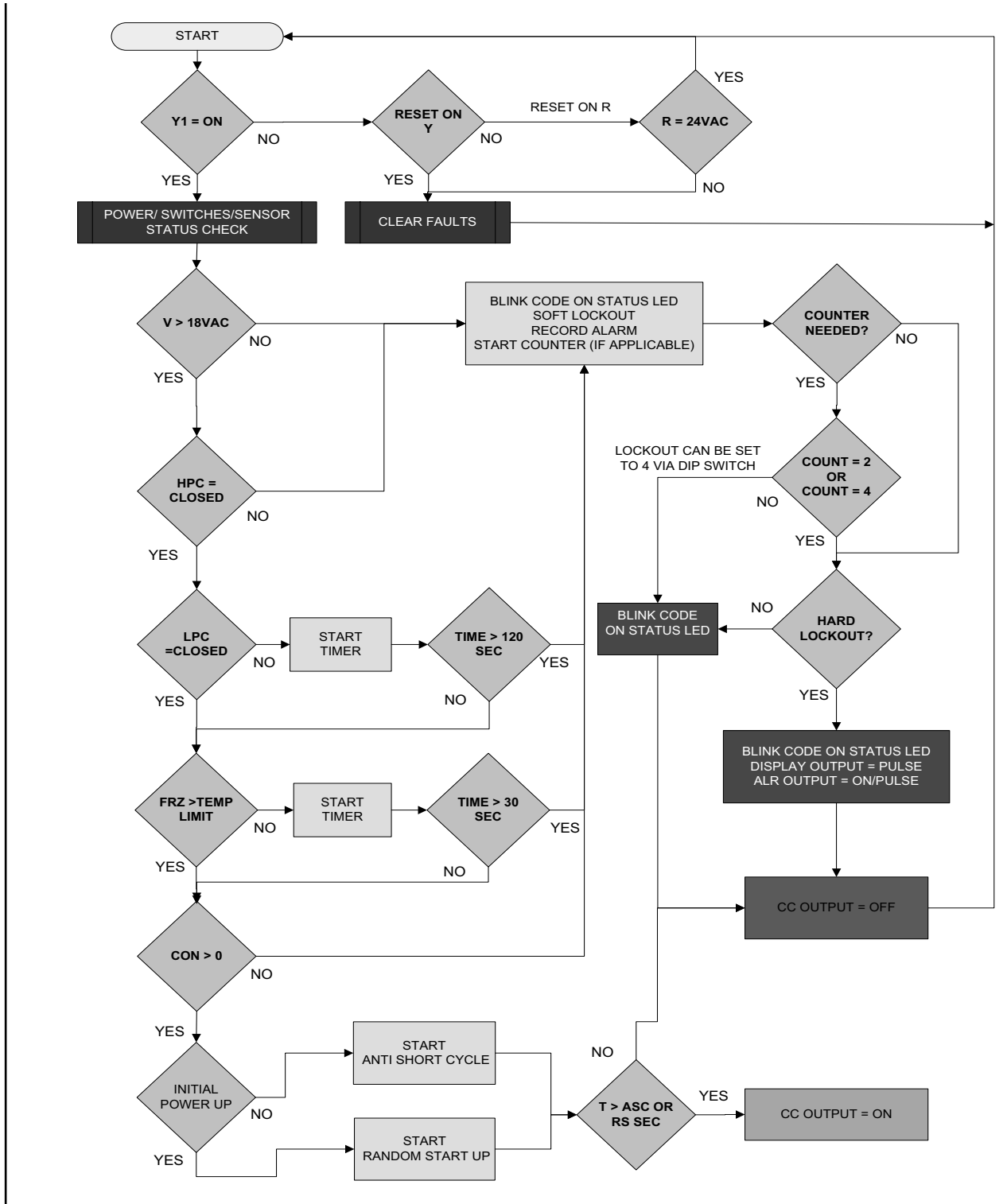

LEGEND:
 HPC - HIGH PRESSURE CUTOUT
 LPC - LOW PRESSURE CUTOUT
 FRZ - FREEZE PROTECTION CONDITION
 CON - CONDENSATE OVERFLOW CONDITION
 CC - COMPRESSOR COIL
 ASC - ANTI SHORT CYCLE

Figure # 14 UPM Sequence of Operation

WATER QUALITY TABLE

POTENTIAL PROBLEM	Water Characteristic	AccEtable Value	
		Copper	Cupro-Nickel
	pH (Acidity/Alkalinity)	7-9	7-9
SCALING	Hardness (CaCO ₃ , MgCO ₃)	< 350 ppm	< 350 ppm
	Ryznar Stability Index	6.0 - 7.5	6.0 - 7.5
	Langelier Saturation Index	-0.5 - +0.5	-0.5 - +0.5

Table 1: Water Quality

CORROSION	Hydrogen Sulfide (H ₂ S)	< 0.5 ppm *	10-50 ppm
	Sulfates	< 125 ppm	< 125 ppm
	Chlorine	< 0.5 ppm	< 0.5 ppm
	Chlorides	< 20 ppm	< 150 ppm
	Carbon Dioxide	< 50 ppm	< 50 ppm
	Ammonia	< 2 ppm	< 2 ppm
	Ammonia Chloride	< 0.5 ppm	< 0.5 ppm
	Ammonia Nitrate	< 0.5 ppm	< 0.5 ppm
	Ammonia Hydroxide	< 0.5 ppm	< 0.5 ppm
	Ammonia Sulfate	< 0.5 ppm	< 0.5 ppm
	Dissolved Solids	< 1,000 ppm	< 1,500 ppm
IRON FOULING	Iron (Fe ²⁺ Iron Bacteria Potential)	< 0.2 ppm	< 0.2 ppm
	Iron Oxide	< 1 ppm	< 1 ppm
EROSION	Suspended Solids	< 10 ppm, < 600 μm size **	< 10 ppm, < 600 μm size **
	Maximum Water Velocity	6 ft/sec	6 ft/sec

* No "rotten egg" smell present at < 0.5 ppm H₂S.

** Equivalent to 30 mesh strainer

HEAT RECOVERY PACKAGE

The Heat Recovery Package (HRP) is a factory mounted option. It consists of a forced pumped unit that employs a circulating pump to move water through a double wall/vented heat exchanger and returns the heated water to the water tank. The water is heated by superheated refrigerant discharge gas from the compressor. This waste heat of the cooling mode captured by the heat recovery increases the capacity and efficiency of the heat pump unit. If the air temperature is uncomfortable coming from the vents in the heating mode the heat recovery may need to be turned off. In the heating mode, the heat recovery captures heat that would normally be used for space heating.

Typical Connection Piping (HRP)

Water Tank Preparation:

1. Turn off electrical or fuel supply to the water heater.
2. Attach garden hose to water tank drain connection and run other end of hose out doors or to an open drain.

3. Close cold water inlet valve to water heater tank.
4. Drain tank by opening drain valve on the bottom of the tank, then open pressure relief valve or hot water faucet.
5. Once drained the tank should be flushed with cold water until the water leaving the drain hose is clear and free of sediment.
6. Close all valves and remove the drain hose.
7. Install HR water piping.



Concentric water fitting (p/n8733907119) is recommended.

HRP Water Piping

All hot water piping should be a minimum of 3/8" O.D. copper tube to a maximum distance of fifteen (15) feet. For distances beyond fifteen feet but not exceeding sixty (60) feet use 1/2" copper tube. Separately insulate all exposed surface of both connecting water lines with 3/8" wall closed cell insulation. Install isolation valves on supply and return to the heat recovery. (Figure #19)

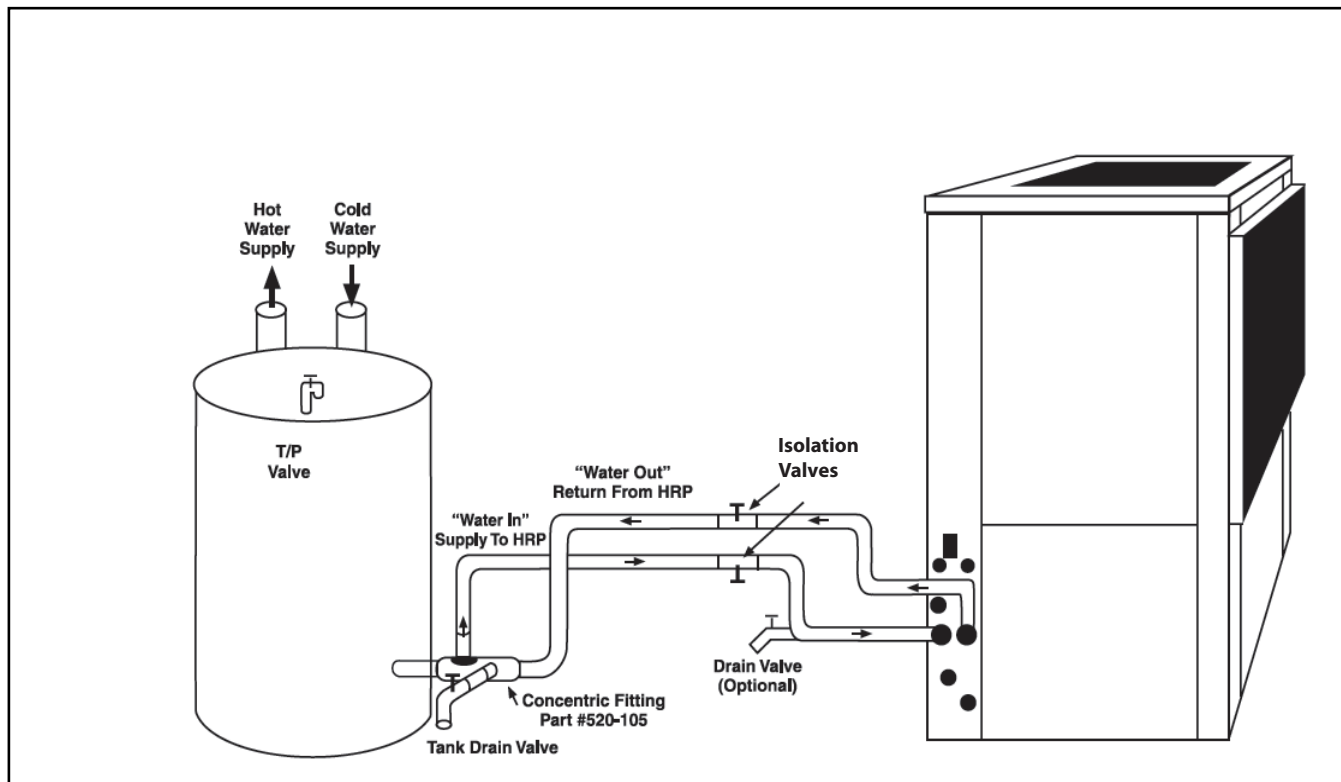

Figure # 15



NOTE: Diagram is for illustration purposes only. Ensure access to heat Pump is not restricted.



NOTE: All piping from HRP to domestic water tank must be copper or any metal of stronger alloy.

WATER TANK REFILL

1. Open the cold water supply to the tank.
2. Open a hot water faucet to vent air from the system until water flows from the faucet, then close.
3. Depress the hot water tank pressure relief valve handle to ensure there is no air remaining in the tank.
4. Carefully inspect all plumbing for water leaks. Correct as required.
5. Purge all air from HR through an external purge valve. Allow all air to bleed out until water appears at the valve. Locate the external purge valve at the highest point in installation.
6. Before restoring the power or fuel supply to the water heater, adjust the temperature setting on the tank thermostat(s) to ensure maximum utilization of the heat available from the refrigeration system and conserve the most energy. On tanks with both upper and lower elements and thermostats, the lower element should be turned down to 100° F, while the upper element should be adjusted to 120° F. Depending upon the specific needs of the customer, you may need to adjust the upper element differently. On tanks with a single thermostat lower the thermostat setting to 120° F or the “LOW” position.



NOTE: After thermostat adjustments are completed, replace access cover and restore electrical or fuel supply to water heater.

Initial Start-Up



NOTE: Make sure all valves in heat recovery water piping system are open. NEVER OPERATE HR PUMP DRY.

1. Turn on the heat pump. The HR pump should not run if the compressor is not running.
2. Turn HR switch to the “ON” position. The pump will operate if entering water temperature to HR is below 120° F.
3. The temperature difference between the water entering and leaving the heat recovery should be 5° to 15° F.
4. Allow the unit to operate for 20 to 30 minutes to ensure it is functioning properly. The pump should shut off when the water temperature entering the heat recovery reaches 120°F.

Hot Gas Reheat (HGRH)

Hot gas reheat is an active dehumidification option available on the EC series that cools and dehumidifies return air, and then reheats it back to approximately entering dry bulb temperature using waste compressor heat. In this way, a unit with Hot Gas Reheat can efficiently remove humidity from the return air without altering the sensible temperature of the space.

There are several ways to control the heat pumps with hot gas reheat. You should choose the means that best suits your specific application. The Typical Wiring Diagram illustrates one possible control sequence. Most heat pump compatible thermostats in conjunction with a humidistat are acceptable for use.



NOTE: Heat pumps with hot Gas Reheat need to be connected to a humidistat along with a traditional thermostat or a combination thermostat/humidistat.



NOTE: “O” output for reversing valve energized in cool mode is required.

SEQUENCE OF OPERATION

Cooling Mode

Energizing the “O” terminal energizes the unit reversing valve in the cooling mode. The fan motor starts when the “G” terminal is energized.



The fan motor will take 30 seconds to ramp up to operating speed and will run at fan only rated air flow as long as there is no call for compressor or heater operation.

When the thermostat calls for first stage cooling (Y1) the loop pump or solenoid valve if present is energized and the first stage of compressor capacity starts. The fan ramps up to first stage cooling air flow in 30 seconds.

When the thermostat calls for second stage cooling (Y2) the second stage (or full compressor capacity) is initiated. The fan ramps up to full cooling air flow.

Once the thermostat is satisfied, the compressor shuts down accordingly and the fan ramps down to either fan only mode or off over a span of 30 seconds.



A fault condition initiating a lockout will de-energize the compressor irrespective of which stage is engaged.

Heating Mode

The first two stages of heating (Y1 & Y2) operate in the same manner as cooling, but with the reversing valve de-energized. On a call for auxiliary heat (W1), the fan ramps up to auxiliary heat air flow immediately and the electric heater package is energized along with the compressor. As the thermostat is satisfied, the heaters will shut off as soon as W1 is de-energized, and the compressors will remain on until the thermostat stages are satisfied. Note that if the unit compressor lock out for any reason at this time, the electric heaters will continue to function normally.

Once the thermostat is satisfied, the compressor shuts down and the fan ramps down either fan only mode or off over a span of 30 seconds.

If thermostat has two different output points one for Auxiliary heat and a different one for Emergency heat the two outputs must be terminated on W1 units equipped with one stage of Electric heat.

APPLICATION CONSIDERATIONS

Well Water Systems



NOTE: In well water applications a slow closing solenoid valve must be used to prevent water hammer.

Copper is adequate for ground water that is not high in mineral content. Should your well driller express concern regarding the quality of the well water available or should any known hazards exist in your area, we recommend proper testing to assure the well water quality is suitable for use with water source equipment. In conditions anticipating moderate scale formation or in brackish water a cupro-nickel heat exchanger is recommended.

In well water applications water pressure must always be maintained in the heat exchanger. This can be accomplished with either control valve or a bladder type expansion tank. When using a single water well to supply both domestic water and the heat pump, care must be taken to insure that the well can provide sufficient flow for both.

Solenoid valves should be connected across Y1 and C1 on the interface board for all. Make sure that the VA draw of the valve does not exceed the contact rating of the thermostat.

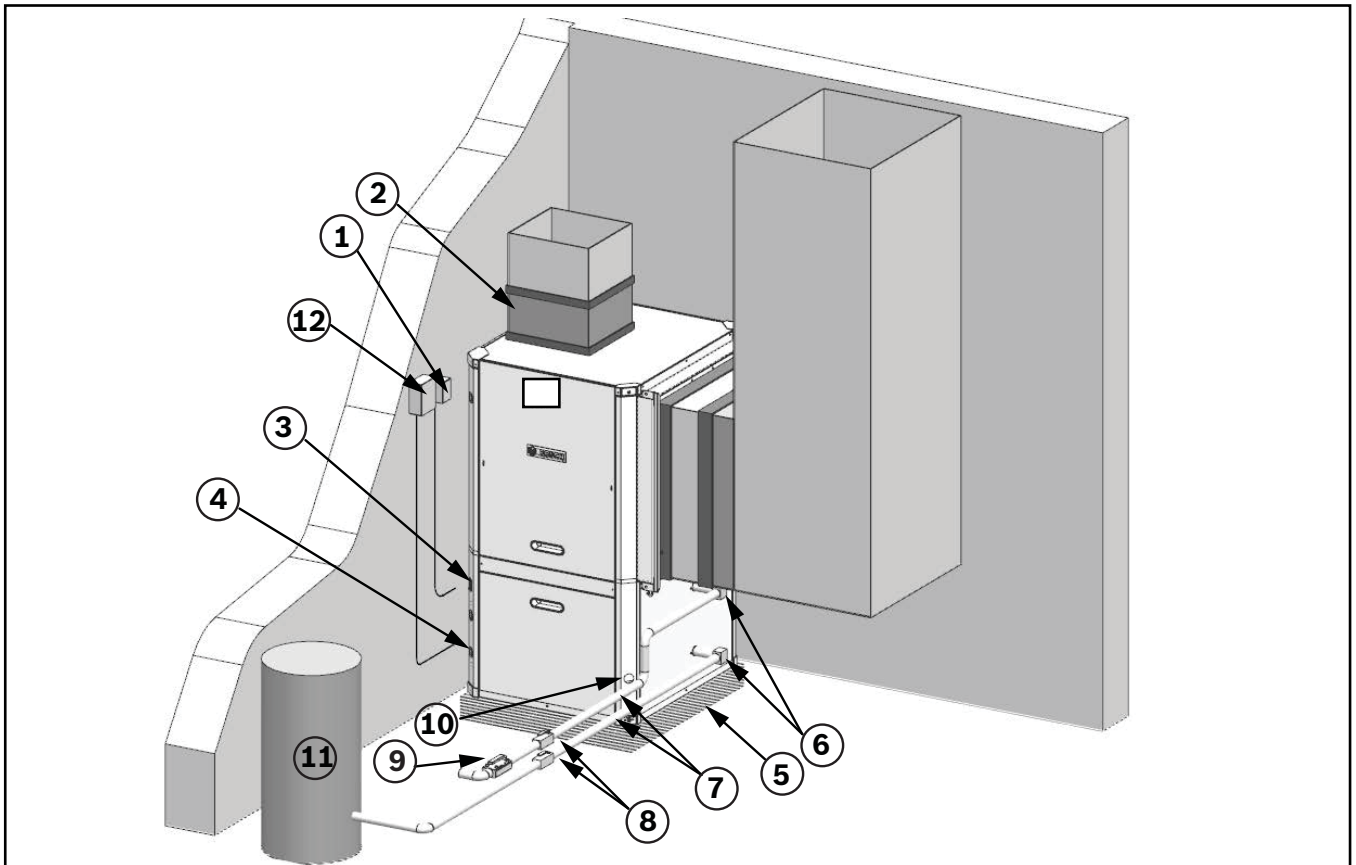

Figure # 16

- [1] Line voltage disconnect (unit)
- [2] Flex duct Connection
- [3] Low voltage control connection
- [4] Line voltage connection
- [5] Vibration pad
- [6] P/T ports
- [7] Hose kits (optional)
- [8] Ball valves
- [9] Solenoid valve slow closing
- [10] Condensate drain connection
- [11] Pressure tank (optional)
- [12] Line voltage disconnect (electric heater)

INSTALLATION OF PRESSURE REGULATING VALVES

Pressure regulating valves are used to increase or decrease water flow through the heat pump in response to refrigerant pressure. In some cases more water may be required in heating than in cooling, or vice versa. With the EC heat pumps these valves are not required.

However, if installed, a pair of valves are required for proper operation, one valve for cooling (direct acting) and another valve for heating (indirect acting).

A refrigerant tap is provided in the refrigerant line located between the reversing valve and the water-to-refrigerant heat exchanger for proper monitoring of the refrigerant pressures.

The discharge water from the heat pump is not contaminated in any manner and can be disposed of in various ways depending on local building codes (i.e. discharge well, dry well, storm sewer, drain field, stream or pond, etc.) Most local codes forbid the use of a sanitary sewer for disposal.

Consult your local building and zoning department to insure compliance in your area.

COOLING TOWER/BOILER SYSTEMS

The cooling tower and boiler water loop temperature is usually maintained between 50° F to 100° F to assure adequate cooling and heating performance.

In the cooling mode, heat is rejected from the unit into the water loop. A cooling tower provides evaporative cooling to the loop water thus maintaining a constant supply temperature to the unit.

When utilizing open cooling towers, chemical water treatment is mandatory to ensure the water is free from corrosive elements. A secondary heat exchanger (plate frame) between the unit and the open cooling tower may also be used. It is imperative that all air be eliminated from the closed loop side of the heat exchanger to insure against fouling.

In the heating mode, heat is absorbed from the water loop. A boiler can be utilized to maintain the loop at the desired temperature.



NOTE: Water piping exposed to extreme low ambient temperatures is subject to freezing.

Consult the specification sheets for piping sizes. Teflon tape sealer should be used when connecting to the unit to insure against leaks and possible heat exchanger fouling. Do not overtighten the connections. Flexible hoses should be used between the unit and the rigid system to avoid possible vibration. Ball valves should be

installed in the supply and return lines for unit isolation and unit water flow balancing. Pressure/temperature ports are recommended in both supply and return lines for system flow balancing. Water flow can be accurately set by measuring the water-to-refrigerant heat exchangers water side pressure drop. See specification sheets for water flow vs. pressure drop information.



NOTE: No unit should be connected to the supply or return piping until the water system has been completely cleaned and flushed to remove any dirt, piping chips or other foreign material.

Supply and return hoses should be connected together during this process to ensure the entire system is properly flushed. After the cleaning and flushing has taken place the unit may be connected to the water loop and should have all valves wide open. (Figure #21)

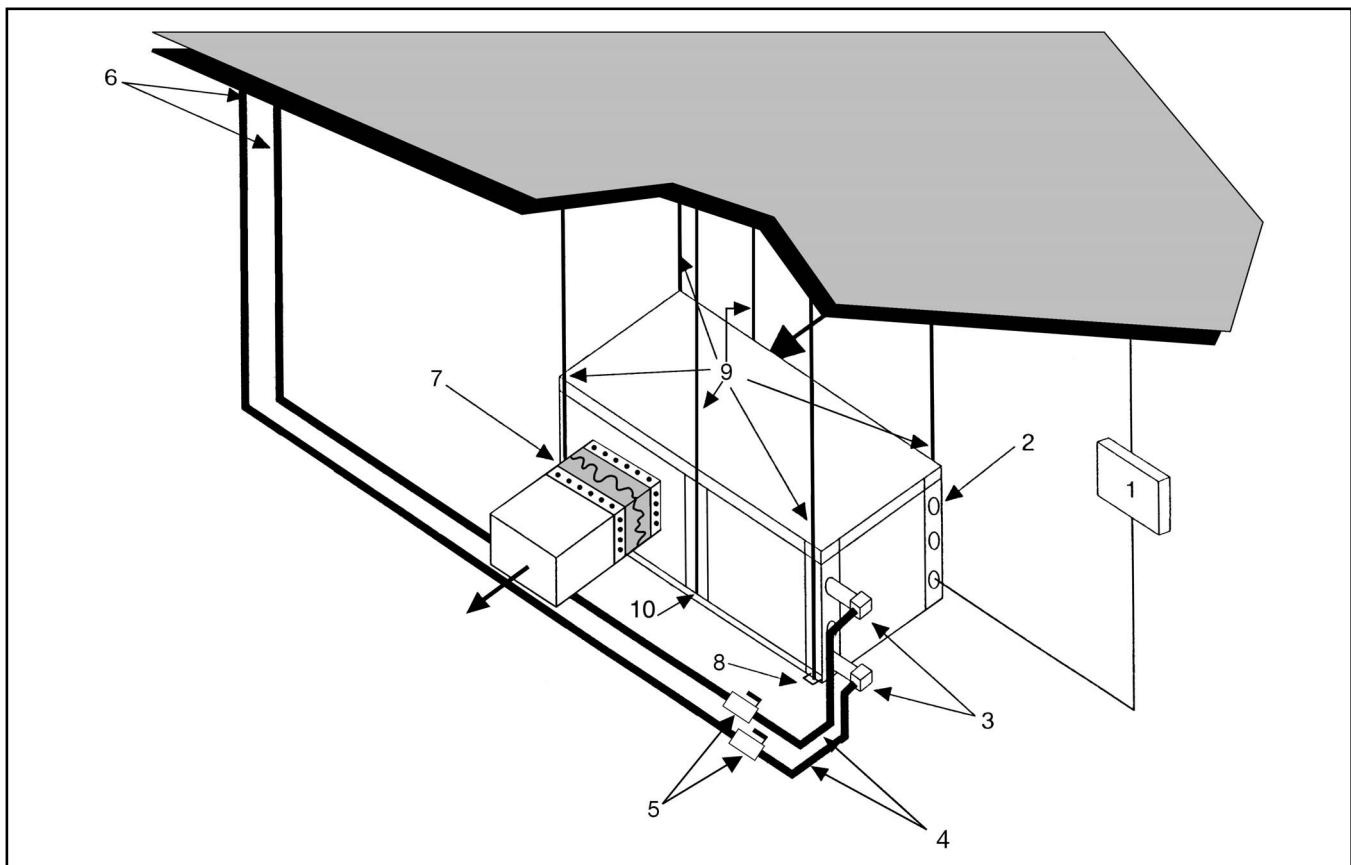

Figure # 17

- | | |
|------------------------------------|--|
| [1] Line voltage disconnect (unit) | [6] Supply and return line of central system |
| [2] Low voltage control connection | [7] Flex duct connection |
| [3] P/T ports (optional) | [8] Hanging bracket assembly |
| [4] Hose kits (optional) | [9] Threaded rod |
| [5] Ball valves | [10] Hanging bracket assembly |

Geothermal (Earth-Coupled) Systems

Closed loop and pond applications require specialized design knowledge. No attempt at these installations should be made unless the dealer has received specialized training. Utilizing the Ground Loop Pumping Package (GLP), makes the

installation easy. Anti-freeze solutions are utilized when low evaporating conditions are expected to occur. Refer to the GLP installation manuals for more specific instructions. (Figure #22)

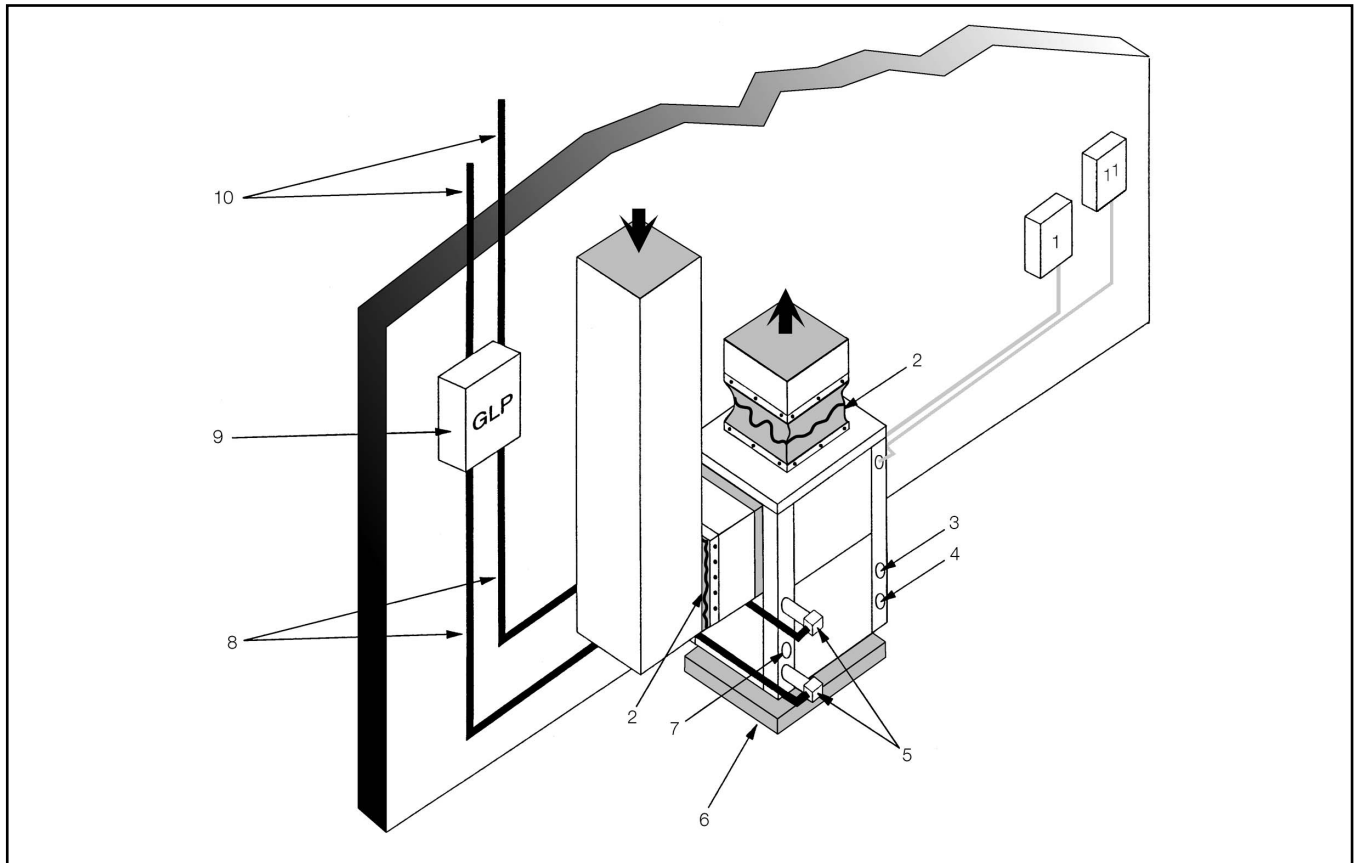

Figure # 18

- [1] Line voltage disconnect (unit)
- [2] Flex duct Connection
- [3] Low voltage control connection
- [4] Line voltage connection (unit)
- [5] P/T ports
- [6] Vibration pad
- [7] Condensate drain connection
- [8] Ground loop connection kit
- [9] Ground loop pumping package
- [10] Polyethylene with insulation
- [11] Line voltage disconnect (electric heater)

SYSTEM CHECKOUT

After completing the installation, and before energizing the unit, the following system checks should be made:

- Verify that the supply voltage to the heat pump is in accordance with the nameplate ratings.
- Make sure that all electrical connections are tight and secure.
- Check the electrical fusing and wiring for the correct size.



WARNING: Ensure cabinet and Electrical Box are properly grounded.

- Verify that the low voltage wiring between the thermostat and the unit is correct.
- Verify that the water piping is complete and correct.
- Check that the water flow is correct, and adjust if necessary.
- Check the blower for free rotation, and that it is secured to the shaft.
- Verify that vibration isolation has been provided.
- Unit is serviceable. Be certain that all access panels are secured in place.

Considerations:



WARNING: Always check incoming line voltage power supply and secondary control voltage for adequacy

1. Transformer primaries are dual tapped for 208 and 230 volts. Connect the appropriate tap to ensure a minimum of 18 volts secondary control voltage. 24 volts is ideal for best operation.
2. Long length thermostat and control wiring leads may create voltage drop. Increase wire gauge or up-size transformers may be required to insure minimum secondary voltage supply.
3. FHP recommends the following guidelines for wiring between a thermostat and the unit: 18 GA up to 60 foot, 16 GA up to 100 ft and 14 GA up to 140 ft.
4. Do not apply additional controlled devices to the control circuit power supply without consulting the factory. Doing so may void equipment warranties.
5. Check with all code authorities on requirements involving condensate disposal/over flow protection criteria.

UNIT START-UP

1. Set the thermostat to the highest setting.
2. Set the thermostat system switch to “COOL”, and the fan switch to the “AUTO” position. The reversing valve solenoid should energize. The compressor and fan should not run.
3. Reduce the thermostat setting approximately 5 degrees below the room temperature.
4. Verify the heat pump is operating in the cooling mode.
5. Turn the thermostat system switch to the “OFF” position. The unit should stop running and the reversing valve should de energize.
6. Leave the unit off for approximately (5) minutes to allow for system equalization.
7. Turn the thermostat to the lowest setting.
8. Set the thermostat switch to “HEAT”.
9. Increase the thermostat setting approximately 5 degrees above the room temperature.
10. Verify the heat pump is operating in the heating mode.
11. Set the thermostat to maintain the desired space temperature.
12. Check for vibrations, leaks, etc.

MAINTENANCE

1. Filter changes or cleaning are required at regular intervals. The time period between filter changes will depend upon type of environment the equipment is used in. In a single family home, that is not under construction, changing or cleaning the filter every 60 days is sufficient. In other applications such as motels, where daily vacuuming produces a large amount of lint, filter changes may be need to be as frequent as biweekly.



NOTE: Equipment should never be used during construction due to likelihood of wall board dust accumulation in the air coil of the equipment which permanently affects the performance and may shorten the life of the equipment.

2. An annual “checkup” is recommended by a licensed refrigeration mechanic. Recording the performance measurements of volts, amps, and water temperature differences (both heating and cooling) is recommended. This data should be compared to the information on the unit’s data plate and the data taken at the original startup of the equipment.
3. Lubrication of the blower motor is not required, however may be performed on some motors to extend motor life. Use SAE-20 non-detergent electric motor oil.
4. The condensate drain should be checked annually by cleaning and flushing to insure proper drainage.
5. Periodic lockouts almost always are caused by air or water flow problems. The lockout (shutdown) of the unit is a normal protective measure in the design of the equipment. If continual lockouts occur call a mechanic immediately and have them check for: water flow problems, water temperature problems, air flow problems or air temperature problems. Use of the pressure and temperature charts for the unit may be required to properly determine the cause.

UNIT CHECK-OUT SHEET

Customer Data

Customer Name _____ Date _____
 Address _____

 Phone _____ Unit Number _____

Unit Nameplate Data

Unit Make _____
 Model Number _____ Serial Number _____
 Refrigerant Charge (oz) _____
 Compressor: RLA _____ LRA _____
 Blower Motor: FLA (or NPA) _____ HP _____
 Maximum Fuse Size (Amps) _____
 Maximum Circuit Ampacity _____

Operating Conditions

	Cooling Mode	Heating Mode
Entering / Leaving Air Temp	_____ / _____	_____ / _____
Entering Air Measured at:	_____	_____
Leaving Air Measured at:	_____	_____
Entering / Leaving Fluid Temp	_____ / _____	_____ / _____
Fluid Flow (gpm)	_____	_____
Compressor Volts / Amps	_____ / _____	_____ / _____
Blower Motor Volts / Amps	_____ / _____	_____ / _____
Source Fluid Type	_____	_____
Fluid Flow (gpm)*	_____	_____
Fluid Side Pressure Drop*	_____	_____
Suction / Discharge Pressure (psig)*	_____ / _____	_____ / _____
Suction / Discharge Temp*	_____ / _____	_____ / _____
Suction Superheat*	_____	_____
Entering TXV / Cap Tube Temp*	_____	_____
Liquid Subcooling*	_____	_____

* Required for Troubleshooting ONLY

Auxiliary Heat

Unit Make _____
 Model Number: _____ Serial Number _____
 Max Fuse Size (Amps) _____
 Volts / Amps _____
 Entering Air Temperature _____
 Leaving Air Temperature _____

Bosch
 555 NW 65th Court
 Fort Lauderdale, FL 33309
 Phone: (954) 776-5471
 Fax: (800) 776-5529



MAIL TO: Bosch.Fhp.TechSupport@us.bosch.com
 or scan the QR code and attach picture of this form with
 the information requested.

TROUBLESHOOTING



NOTE: Troubleshooting Information Solution column may reflect a possible fault that may be one of, or a combination of causes and solutions. Check each cause and adopt “process of elimination” and or verification of each before making any conclusion.

UPM Board LED Indications		
Indication Color	Blinks	Description
GREEN	Solid	18-30 VAC Power is present
RED	1	High pressure lockout
RED	2	Low pressure lockout
RED	3	Freeze sensor lockout
RED	4	Condensate overflow
RED	5	Brownout
RED	6	Evaporator Freeze condition

Unit Troubleshooting		
Problem	Possible Cause	Checks and Correction
ENTIRE UNIT DOES NOT RUN	Power Supply Off	Apply power, close disconnect
	Blown Fuse	Replace fuse or reset circuit breaker. Check for correct fuses
	Voltage Supply Low	If voltage is below minimum voltage specified on unit data plate, contact local power company.
	Thermostat	Set the fan to “ON”, the fan should run. Set thermostat to “COOL” and lowest temperature setting, the unit should run in the cooling mode (reversing valve energized). Set unit to “HEAT” and the highest temperature setting, the unit should run in the heating mode. If neither the blower or compressor run in all three cases, the thermostat could be miswired or faulty. To ensure miswired or faulty thermostat verify 24 volts is available on the condensing section low voltage terminal strip between “R” and “C”, “Y” and “C”, and “O” and “C”. If the blower does not operate, verify 24 volts between terminals “G” and “C” in the air handler. Replace the thermostat if defective.
BLOWER OPERATES BUT COMPRESSOR DOES NOT	Thermostat	Check setting, calibration, and wiring
	Wiring	Check for loose or broken wires at compressor, capacitor, or contactor.
	Safety Controls	Check UPM board red default L.E.D. for Blink Code
	Compressor overload open	If the compressor is cool and the overload will not reset, replace compressor.
	Compressor motor grounded	Internal winding grounded to the compressor shell. Replace compressor. If compressor burnout, install suction filter dryer.
	Compressor windings Open	After compressor has cooled, check continuity of the compressor windings. If the windings are open, replace the compressor

Unit Troubleshooting		
Problem	Possible Cause	Checks and Correction
UNIT OFF ON HIGH PRESSURE CONTROL	Discharge pressure too high	In "COOLING" mode: Lack of or inadequate water flow. Entering water temperature is too warm. Scaled or plugged condenser. In "HEATING" mode: Lack of or inadequate air flow. Blower inoperative, clogged filter or restrictions in duct work
	Refrigerant charge	The unit is overcharged with refrigerant. Reclaim refrigerant, evacuate and recharge with factor recommended charge.
	High pressure	Check for defective or improperly calibrated high pressure switch.
UNIT OFF ON LOW PRESSURE CONTROL	Suction pressure too low	In "COOLING" mode: Lack of or inadequate air flow. Entering air temperature is too cold. Blower inoperative, clogged filter or restrictions in duct work. In "HEATING" mode: Lack of or inadequate water flow. Entering water temperature is too cold. Scaled or plugged condenser.
	Refrigerant charge	The unit is low on refrigerant. Check for refrigerant leak, repair, evacuate and recharge with factory recommended charge.
	Low pressure switch	Check for defective or improperly calibrated low pressure switch.
UNIT SHORT CYCLES	Unit oversized	Recalculate heating and or cooling loads.
	Thermostat	Thermostat installed near a supply air grill; relocate thermostat. Readjust heat anticipator.
	Wiring and controls	Check for defective or improperly calibrated low pressure switch.
INSUFFICIENT COOLING OR HEATING	Unit undersized	Recalculate heating and or cooling loads. If excessive, possibly adding insulation and shading will rectify the problem
	Loss of conditioned air by leakage	Check for leaks in duct work or introduction of ambient air through doors or windows
	Airflow	Lack of adequate air flow or improper distribution of air. Replace dirty filter
	Refrigerant charge	Low on refrigerant charge causing inefficient operation
	Compressor	Check for defective compressor. If discharge is too low and suction pressure is too high, compressor is not pumping properly. Replace compressor.
	Reversing Valve	Defective reversing valve creating bypass of refrigerant from discharge of suction side of compressor. Replace reversing valve
	Operating pressures	Compare unit operation pressures to the pressure/temperature chart for the unit.
	TXV	Check TXV for possible restriction or defect. Replace if necessary.
	Moisture, non condensable	The refrigerant system may be contaminated with moisture or non condensable. Reclaim refrigerant, replace filter dryer, evacuate the refrigerant system, and recharge with factory recommended charge.

HRP Troubleshooting		
Problem	Possible Cause	Checks and Corrections
NO FLOW LOW FLOW	No Power	Check power supply
	On/Off Switch Position	Set switch to "ON" position
	Compressor Contactor	Engage heat pump contactor
	Broken or loose wires	Repair or tighten wires
	Air Lock	Purge air from piping system
	Stuck pump shaft/impeller	Remove pump cartridge and clean
	Defective pump	Replace pump
	Kinked or under sized water piping	Repair kink and check for proper line size
HIGH WATER TEMPERATURE	Water temp limit closed	Stuck limit switch Sensor not attached securely to line
LOW HEAT OUTPUT	Scaled or fouled heat exchanger	Clean heat exchanger

TABLE BELT DRIVE MOTOR

Model	Voltage Code	Rated Voltage	Voltage Min/Max	Compressor			Total Unit w/ Belt Drive Motor				Compressor Service			
				QTY	RLA (each)	LRA (each)	Motor Qty	FLA	Min Circuit Amps	Max Fuse/HACR	Cold Winding Resistance	Single Phase R-C	Single Phase S-C	Three Phase Line-Line
072	1	208-230/1/60	197/253	2	13.0	74	1	7	36.3	45	0.82	1.63	-	40/370
	3	208-230/3/60	197/253	2	7.8	68	1	3.6	21.2	25	-	-	1.15	-
	4	460/3/60	414/506	2	3.9	34	1	1.8	10.6	15	-	-	4.61	-
096	1	208-230/1/60	197/253	2	15.7	84	1	8.4/9.8	47.6/45.1	50/60	0.54	1.60	-	45/370
	3	208-230/3/60	197/253	2	11.0	88	1	4.8/6.2	29.5/31.0	40/40	-	-	0.93	-
	4	460/3/60	414/506	2	5.4	44	1	2.4/3.1	14.6/15.2	15/20	-	-	3.59	-
	5	575/3/60	518/632	2	4.4	36	1	2.0/2.6	11.9/12.5	15/15	-	-	5.68	-
120	1	208-230/1/60	197/253	2	26.3	134	1	9.8	69.0	90	0.45	0.79	-	80/370
	3	208-230/3/60	197/253	2	15.6	110	1	6.2/9.2	41.3/44.3	50/50	-	-	0.68	-
	4	460/3/60	414/506	2	7.8	52	1	3.1/4.3	20.6/21.9	25/25	-	-	3.20	-
	5	575/3/60	518/632	2	5.8	39	1	2.6/3.7	15.7/16.8	20/20	-	-	5.33	-
150	3	208-230/3/60	197/253	2	19.2	136	1	9.2	52.4	70	-	-	0.60	-
	4	460/3/60	414/506	2	8.7	66	1	4.3	23.9	30	-	-	2.52	-
	5	575/3/60	518/632	2	6.9	55	1	3.7	19.2	25	-	-	3.74	-
151	3	208-230/3/60	197/253	2	19.2	136	1	9.2	52.4	70	-	-	0.60	-
	4	460/3/60	414/506	2	8.7	66	1	4.3	23.9	30	-	-	2.52	-
	5	575/3/60	518/632	2	6.9	55	1	3.7	19.2	25	-	-	3.74	-
180	3	208-230/3/60	197/253	2	22.4	149	2	6.2	62.8	80	-	-	0.56	-
	4	460/3/60	414/506	2	10.6	75	2	3.2	30.1	40	-	-	2.27	-
	5	575/3/60	518/632	2	7.7	54	2	2.6	22.5	30	-	-	3.56	-
181	3	208-230/3/60	197/253	2	22.4	149	1	12.2	62.6	80	-	-	0.56	-
	4	460/3/60	414/506	2	10.6	75	1	6.1	30.0	40	-	-	2.27	-
	5	575/3/60	518/632	2	7.7	54	1	5.4	22.7	30	-	-	3.56	-
210	3	208-230/3/60	197/253	2	29.5	195	2	4.8	76.0	100	-	-	0.40	-
	4	460/3/60	414/506	2	14.7	95	2	2.4	37.9	50	-	-	1.59	-
	5	575/3/60	518/632	2	12.2	80	2	2	31.5	40	-	-	2.55	-
240	3	208-230/3/60	197/253	2	30.1	225	2	6.2	80.1	110	-	-	0.35	-
	4	460/3/60	414/506	2	16.7	114	2	3.1	43.8	60	-	-	1.36	-
	5	575/3/60	518/632	2	12.2	80	2	2.6	32.6	40	-	-	2.55	-
242	3	208-230/3/60	197/253	2	30.1	225	2	6.2	80.1	110	-	-	0.35	-
	4	460/3/60	414/506	2	16.7	114	2	3.1	43.8	60	-	-	1.36	-
	5	575/3/60	518/632	2	12.2	80	2	2.6	32.6	40	-	-	2.55	-
300	3	208-230/3/60	197/253	2	48.1	245	2	9.2	126.6	150	-	-	0.28	-
	4	460/3/60	414/506	2	18.6	125	2	4.3	50.5	60	-	-	1.24	-
	5	575/3/60	518/632	2	14.7	100	2	3.7	40.5	50	-	-	1.88	-
360	3	208-230/3/60	197/253	2	55.8	340	2	12.2	150.0	200	-	-	0.21	-
	4	460/3/60	414/506	2	26.9	173	2	6.1	72.7	90	-	-	0.83	-
	5	575/3/60	518/632	2	23.7	132	2	5.4	64.1	80	-	-	1.27	-

BLOWER PERFORMANCE

Model	Motor Sheave	Rated Airflow	External Static Pressure (in wc Wet coil and filter included)											
			0.10	0.20	0.30	0.40	0.50	0.60	0.70	0.80	0.90	1.00	1.10	1.20
072	Closed		-	-	-	-	-	-	-	-	2420	2160	1900	1700
	Half Open	2,300	-	-	2980	2800	2610	2400	2100	1800	-	-	-	-
	Open		2780	2590	2350	2050	1780	-	-	-	-	-	-	-
096	Closed		-	-	-	-	-	-	-	2800	2650	2450	2300	2200
	Half Open	2,800	-	-	3480	3340	3230	3075	2880	2690	2555	2355	-	-
	Open		3110	2965	2835	2615	2460	2275	-	-	-	-	-	-
120	Closed		-	-	-	-	-	-	-	-	4400	4150	3830	3600
	Half Open	4,000	-	-	-	4660	4490	4240	3959	4600	3000	-	-	-
	Open		4680	4490	4270	4000	3700	3370	-	-	-	-	-	-
150	Closed		-	-	-	-	-	-	7120	6920	6530	6080	5660	5120
	Half Open	5,000	-	-	-	6860	6530	6120	5780	5380	4880	4090	-	-
	Open		6770	6300	5880	5430	4970	4340	3750	-	-	-	-	-
151	Closed		-	-	-	-	-	-	7120	6920	6530	6080	5660	5120
	Half Open	5,000	-	-	-	6860	6530	6120	5780	5380	4880	4090	-	-
	Open		6770	6300	5880	5430	4970	4340	3750	-	-	-	-	-
180	Closed		-	-	-	-	-	-	7200	6940	6560	6150	5710	5140
	Half Open	6,000	-	-	7200	6930	6580	6200	5800	5450	4920	-	-	-
	Open		6780	6350	5970	5540	5050	4510	-	-	-	-	-	-
181	Closed		-	-	-	-	-	-	7200	6940	6560	6150	5710	5140
	Half Open	6,000	-	-	7200	6930	6580	6200	5800	5450	4920	-	-	-
	Open		6780	6350	5970	5540	5050	4510	-	-	-	-	-	-
210	Closed		-	-	-	-	-	-	-	-	-	-	7800	7500
	Half Open	7,000	-	-	-	-	-	8600	8200	7600	6900	5240	-	-
	Open		8840	8400	8000	7560	7000	6400	-	-	-	-	-	-
240	Closed		-	-	-	-	-	-	-	-	9000	8800	8330	7660
	Half Open	8,000	-	-	-	-	9320	8980	8480	7900	7200	6000	-	-
	Open		9360	8980	8540	8000	7400	6740	-	-	-	-	-	-
242	Closed		-	-	-	-	-	-	-	-	-	-	8120	7500
	Half Open	8,000	-	-	-	-	-	-	8280	7700	7000	5800	-	-
	Open		-	-	8340	7800	7200	6540	-	-	-	-	-	-
300	Closed		-	-	-	-	10000	9650	9300	8950	8600	8200	-	-
	Half Open	10,00	-	10500	10100	9700	8900	8500	8100	-	-	-	-	-
	Open		9900	9100	8700	8300	-	-	-	-	-	-	-	-

Model	Motor Sheave	Rated Airflow	External Static Pressure (in wc Wet coil and filter included)											
			0.2	0.3	0.4	0.6	0.8	1.0	1.2	1.4	1.6	1.8	2.0	2.2
360	Closed		-	-	-	-	-	-	-	-	-	-	12900	10800
	Half Open	12,00	-	-	-	-	-	13050	11850	10350	7500	-	-	-
	Open		12200	11575	10950	9600	7800	-	-	-	-	-	-	-

WATER SIDE PRESSURE DROP

Model	GPM	Pressure Drop (PSIG)	Pressure Drop (ft of H2O)
EC072	10	2.6	6.0
	12	3.6	8.3
	14	4.8	11.0
	16	6.1	14.0
	18	7.5	17.3
EC096	12	2.5	5.7
	14	3.3	7.5
	18	5.1	11.8
	21	6.8	15.6
	24	8.6	19.8
EC120	16	2.1	4.9
	20	3.1	7.3
	24	4.4	10.1
	28	5.8	13.3
	32	7.3	16.9
EC150	20	1.4	3.3
	25	2.1	4.9
	30	3.0	6.8
	35	3.9	9.0
	50	7.4	17.1
EC151	20	1.4	3.3
	25	2.1	4.9
	30	3.0	6.8
	35	3.9	9.0
	50	7.4	17.1
EC181	22	1.7	3.9
	27	2.5	5.7
	32	3.3	7.7
	42	5.4	12.5
	52	8.0	18.4

Model	GPM	Pressure Drop (PSIG)	Pressure Drop (ft of H2O)
EC210	30	2.6	5.9
	40	4.3	9.9
	50	6.4	14.9
	60	8.9	20.6
	70	11.8	27.2
EC240	30	1.6	3.7
	40	2.7	6.2
	50	4.0	9.3
	60	5.6	12.9
	75	8.3	19.2
EC242	30	1.6	3.7
	40	2.7	6.2
	50	4.0	9.3
	60	5.6	12.9
	75	8.3	19.2
EC300	40	2.7	6.2
	50	4.0	9.3
	60	5.6	12.9
	75	8.3	19.2
	85	10.4	24.1
EC360	50	3.7	8.5
	70	6.7	15.5
	80	8.5	19.7
	90	10.6	24.4
	100	12.8	29.5

OPERATING TEMPERATURES AND PRESSURES

MODEL	ENTERING WATER TEMP, °F	WATER FLOW GPM	COOLING				HEATING			
			SUCTION PRESSURE PSIG	DISCHARGE PRESSURE PSIG	WATER TEMP RISE, °F	AIR TEMP DROP, °F	SUCTION PRESSURE PSIG	DISCHARGE PRESSURE PSIG	WATER TEMP DROP, °F	AIR TEMP RISE, °F
EC072	30°	10.0					65-80	282-344	6-7	14-17
		16.0					73-89	294-359	3-4	15-18
	40°	10.0	121-148	184-225	17-21	18-22	80-98	299-365	7-9	16-20
		16.0	117-143	167-204	10-13	19-23	89-108	311-380	4-5	17-21
	50°	10.0	123-151	222-271	17-20	17-21	95-116	315-385	9-11	19-23
		16.0	119-145	202-247	10-12	18-23	105-128	329-402	5-7	20-24
	60°	10.0	125-153	260-318	16-19	17-21	109-133	332-406	11-13	21-26
		16.0	120-147	237-289	10-12	18-22	121-148	346-423	6-8	22-27
	70°	10.0	127-155	298-365	15-19	17-20	124-151	349-427	12-15	23-28
		16.0	122-149	271-331	9-11	18-21	138-168	364-444	7-9	25-30
	80°	10.0	129-158	336-411	14-18	16-20	138-169	366-447	14-17	26-31
		16.0	124-152	306-374	9-11	17-21	154-188	381-466	8-10	27-33
90°	10.0	131-160	374-458	14-17	16-19	153-187	383-468	16-19	28-34	
	16.0	126-154	340-416	8-10	17-20	170-208	399-487	9-12	29-36	
100°	10.0	133-162	413-504	13-16	15-19					
	16.0	128-156	375-458	8-10	16-20					
EC096	30°	13.0					72-87	296-361	5-6	21-25
		22.0					75-92	301-368	3-4	22-26
	40°	13.0	114-139	155-190	14-17	22-27	88-107	314-384	6-7	24-29
		22.0	108-132	147-180	10-12	23-28	92-112	321-392	4-5	25-30
	50°	13.0	116-142	192-234	13-16	21-26	104-127	333-407	7-9	27-33
		22.0	111-135	182-222	9-12	22-27	109-133	340-415	5-6	28-34
	60°	13.0	119-146	228-279	13-16	21-26	120-146	352-430	8-10	30-37
		22.0	113-138	217-265	9-11	22-27	125-153	359-439	6-7	32-39
	70°	13.0	122-149	264-323	13-15	20-25	136-166	371-453	9-12	33-41
		22.0	116-142	251-307	9-11	21-26	142-174	378-462	7-8	35-43
	80°	13.0	125-152	301-368	12-15	20-24	152-185	389-476	11-13	36-44
		22.0	118-145	286-349	9-11	21-26	159-194	397-485	8-9	38-47
90°	13.0	127-156	337-412	12-15	19-24	168-205	408-499	12-15	39-48	
	22.0	121-148	320-392	9-10	20-25	176-215	416-509	8-10	41-51	
100°	13.0	130-159	374-457	12-14	19-23					
	22.0	124-151	355-434	8-10	20-24					
EC120	30°	16.0					73-89	266-325	5-6	15-18
		32.0					77-94	272-333	3-4	16-19
	40°	16.0	117-143	189-231	14-17	18-22	86-105	279-341	6-7	17-21
		32.0	112-137	178-217	8-9	19-24	90-110	286-350	4-5	18-22
	50°	16.0	126-154	221-270	14-17	18-21	162-198	293-358	7-8	20-24
		32.0	121-148	207-253	8-9	19-23	170-208	300-366	5-6	21-25
	60°	16.0	131-160	252-308	13-16	17-21	110-134	306-374	8-10	22-27
		32.0	125-153	237-290	8-9	18-22	115-141	314-383	6-7	23-29
	70°	16.0	135-165	284-347	13-16	17-20	122-150	320-391	9-11	24-30
		32.0	130-158	266-326	7-9	18-22	129-157	327-400	6-8	26-32
	80°	16.0	140-171	320-391	13-16	16-20	134-164	333-407	11-13	27-33
		32.0	134-164	300-367	7-9	17-21	141-172	341-417	7-9	28-35
90°	16.0	144-176	360-440	13-16	16-19	147-179	347-424	12-14	29-36	
	32.0	138-169	338-414	7-9	17-21	154-188	355-434	8-10	31-38	
100°	16.0	149-182	405-495	13-15	15-19					
	32.0	143-174	381-465	7-9	16-20					

		OPERATING DATA									
		COOLING					HEATING				
MODEL	ENTERING WATER TEMP, °F	WATER FLOW GPM	SUCTION PRESSURE PSIG	DISCHARGE PRESSURE PSIG	WATER TEMP RISE, °F	AIR TEMP DROP, °F	SUCTION PRESSURE PSIG	DISCHARGE PRESSURE PSIG	WATER TEMP DROP, °F	AIR TEMP RISE, °F	
EC150 EC151	30°	22.0					74-90	244-299	3-4	13-15	
		38.0					78-95	251-306	2-3	13-16	
	40°	22.0	122-149	183-224	14-18	19-23	87-106	257-314	4-5	15-18	
		38.0	117-143	172-210	8-10	20-24	91-111	263-322	3-3	16-19	
	50°	22.0	131-160	214-261	14-18	18-22	164-201	269-329	5-6	17-20	
		38.0	126-154	201-245	8-10	19-24	173-211	276-337	3-4	18-22	
	60°	22.0	136-166	244-298	14-17	18-22	111-136	282-344	6-7	19-23	
		38.0	131-160	230-281	8-10	19-23	117-143	289-353	4-5	20-24	
	70°	22.0	141-172	275-336	14-17	17-21	124-152	294-360	7-8	21-25	
		38.0	135-165	258-316	8-10	18-22	131-160	302-369	5-6	22-27	
	80°	22.0	145-178	310-378	14-17	17-20	136-166	307-375	8-9	23-28	
		38.0	140-171	291-356	8-10	18-22	143-175	314-384	5-6	24-30	
	90°	22.0	150-183	349-426	14-17	16-19	149-182	319-390	8-10	25-30	
		38.0	144-176	328-401	8-9	17-21	156-191	327-400	6-7	26-32	
	100°	22.0	155-189	392-480	13-16	16-19					
		38.0	149-182	369-451	8-9	17-21					
	EC180 EC181	30°	25.0					64-78	248-303	5-6	15-18
			45.0					67-82	254-311	3-4	16-19
40°		25.0	109-134	183-224	18-22	19-23	75-91	261-319	6-8	17-21	
		45.0	105-128	172-210	10-12	20-25	79-96	267-327	4-5	18-23	
50°		25.0	118-144	214-261	18-22	19-23	142-173	273-334	8-10	20-24	
		45.0	113-138	201-245	10-12	20-24	149-182	280-342	5-7	21-26	
60°		25.0	122-149	244-298	17-21	18-22	96-117	286-349	9-11	22-27	
		45.0	117-143	230-281	10-12	19-24	101-123	293-358	6-8	24-29	
70°		25.0	126-154	275-336	17-21	18-22	107-131	299-365	11-13	25-30	
		45.0	121-148	258-316	10-12	19-23	113-138	306-374	7-9	26-32	
80°		25.0	130-159	310-378	17-21	17-21	117-143	311-380	12-15	27-33	
		45.0	125-153	291-356	10-12	18-22	123-151	319-390	8-10	29-35	
90°		25.0	134-164	349-426	17-20	17-20	128-157	324-396	13-16	29-36	
		45.0	129-158	328-401	9-12	18-22	135-165	332-406	9-11	31-38	
100°		25.0	139-170	392-480	16-20	16-20					
		45.0	133-163	369-451	9-11	17-21					
EC210		30°	28.0					71-87	277-339	6-7	15-19
			52.0					75-92	284-347	4-5	16-20
	40°	28.0	118-144	194-237	21-25	19-23	84-102	291-356	7-9	18-22	
		52.0	113-138	182-223	12-14	20-24	88-108	299-365	5-6	19-23	
	50°	28.0	127-155	226-276	21-25	18-22	159-194	305-373	9-11	20-25	
		52.0	122-149	213-260	12-14	19-24	167-204	313-383	6-7	21-26	
	60°	28.0	131-160	259-316	21-25	18-22	108-132	320-391	10-13	23-28	
		52.0	126-154	243-297	12-14	19-23	113-138	328-400	7-9	24-29	
	70°	28.0	136-166	291-355	20-25	17-21	120-147	334-408	12-15	25-31	
		52.0	130-159	273-334	12-14	18-22	126-154	342-418	8-10	27-32	
	80°	28.0	140-171	328-401	20-24	17-20	131-161	348-425	14-17	27-34	
		52.0	135-165	308-377	11-14	18-22	138-169	356-436	9-11	29-36	
	90°	28.0	145-177	369-451	20-24	16-20	144-176	362-442	15-18	30-37	
		52.0	139-170	347-424	11-14	17-21	151-185	371-453	10-12	32-39	
	100°	28.0	149-183	415-508	19-24	16-19					
		52.0	143-175	391-477	11-14	17-21					

			OPERATING DATA								
			COOLING				HEATING				
MODEL	ENTERING WATER TEMP, °F	WATER FLOW GPM	SUCTION PRESSURE PSIG	DISCHARGE PRESSURE PSIG	WATER TEMP RISE, °F	AIR TEMP DROP, °F	SUCTION PRESSURE PSIG	DISCHARGE PRESSURE PSIG	WATER TEMP DROP, °F	AIR TEMP RISE, °F	
EC240 EC242	30°	32.0					68-84	256-313	5-7	19-23	
		64.0					73-89	261-319	4-5	20-25	
	40°	32.0	113-138	172-210	18-22	19-23	81-99	277-339	7-8	22-26	
		64.0	110-134	161-196	12-14	20-24	86-105	283-346	5-6	23-28	
	50°	32.0	116-142	206-252	17-21	19-23	93-114	299-365	8-9	24-29	
		64.0	112-137	193-236	12-14	19-24	99-121	305-373	6-7	25-31	
	60°	32.0	118-145	241-294	17-21	18-23	106-129	321-392	9-11	26-32	
		64.0	115-140	225-275	11-14	19-23	113-138	327-400	7-8	28-34	
	70°	32.0	121-148	275-336	17-21	18-22	118-145	342-418	10-12	29-35	
		64.0	117-143	257-314	11-14	19-23	126-154	349-427	8-9	30-37	
	80°	32.0	123-151	309-378	16-20	18-22	131-160	364-444	11-14	31-38	
		64.0	120-146	289-353	11-13	19-23	139-170	371-454	8-10	33-40	
	90°	32.0	126-154	344-420	16-20	18-22	143-175	385-471	12-15	33-41	
		64.0	122-149	321-392	11-13	18-22	152-186	393-480	9-11	35-43	
	100°	32.0	128-157	378-462	16-19	17-21					
		64.0	125-152	353-432	11-13	18-22					
	EC300	30°	45.0					68-84	256-313	5-7	19-23
			75.0					73-89	261-319	4-5	20-25
40°		45.0	117-143	210-256	15-19	21-26	81-99	277-339	7-8	22-26	
		75.0	114-139	196-239	11-14	22-27	86-105	283-346	5-6	23-28	
50°		45.0	120-147	243-297	15-18	20-25	93-114	299-365	8-9	24-29	
		75.0	117-143	227-277	11-14	21-26	99-121	305-373	6-7	25-31	
60°		45.0	123-150	276-337	14-17	20-24	106-129	321-392	9-11	26-32	
		75.0	119-146	258-315	11-13	21-25	113-138	327-400	7-8	28-34	
70°		45.0	126-154	309-378	14-17	19-24	107-131	299-365	11-13	25-30	
		75.0	121-148	258-316	10-12	19-23	113-138	306-374	7-9	26-32	
80°		45.0	130-159	310-378	17-21	17-21	117-143	311-380	12-15	27-33	
		75.0	125-153	320-391	10-12	19-24	139-170	371-454	8-10	33-40	
90°		45.0	132-161	376-459	13-16	18-22	143-175	385-471	12-15	33-41	
		75.0	128-156	351-429	10-12	19-23	152-186	393-480	9-11	35-43	
100°		45.0	134-164	409-500	12-15	17-21					
		75.0	131-160	382-467	9-11	17-21					
EC360		30°	50.0					65-80	282-344	6-7	14-17
			90.0					73-89	294-359	3-4	15-18
	40°	50.0	121-148	184-225	17-21	18-22	80-98	299-365	7-9	16-20	
		90.0	117-143	167-204	10-13	19-23	89-108	311-380	4-5	17-21	
	50°	50.0	123-151	222-271	17-20	17-21	95-116	315-385	9-11	19-23	
		90.0	119-145	202-247	10-12	18-23	105-128	329-402	5-7	20-24	
	60°	50.0	125-153	260-318	16-19	17-21	109-133	332-406	11-13	21-26	
		90.0	120-147	237-289	10-12	18-22	121-148	346-423	6-8	22-27	
	70°	50.0	127-155	298-365	15-19	17-20	124-151	349-427	12-15	23-28	
		90.0	122-149	271-331	9-11	18-21	138-168	364-444	7-9	25-30	
	80°	50.0	129-158	336-411	14-18	16-20	138-169	366-447	14-17	26-31	
		90.0	124-152	306-374	9-11	17-21	154-188	381-466	8-10	27-33	
	90°	50.0	131-160	374-458	14-17	16-19	153-187	383-468	16-19	28-34	
		90.0	126-154	340-416	8-10	17-20	170-208	399-487	9-12	29-36	
	100°	50.0	133-162	413-504	13-16	15-19					
		90.0	128-156	375-458	8-10	16-20					

WIRING DIAGRAMS

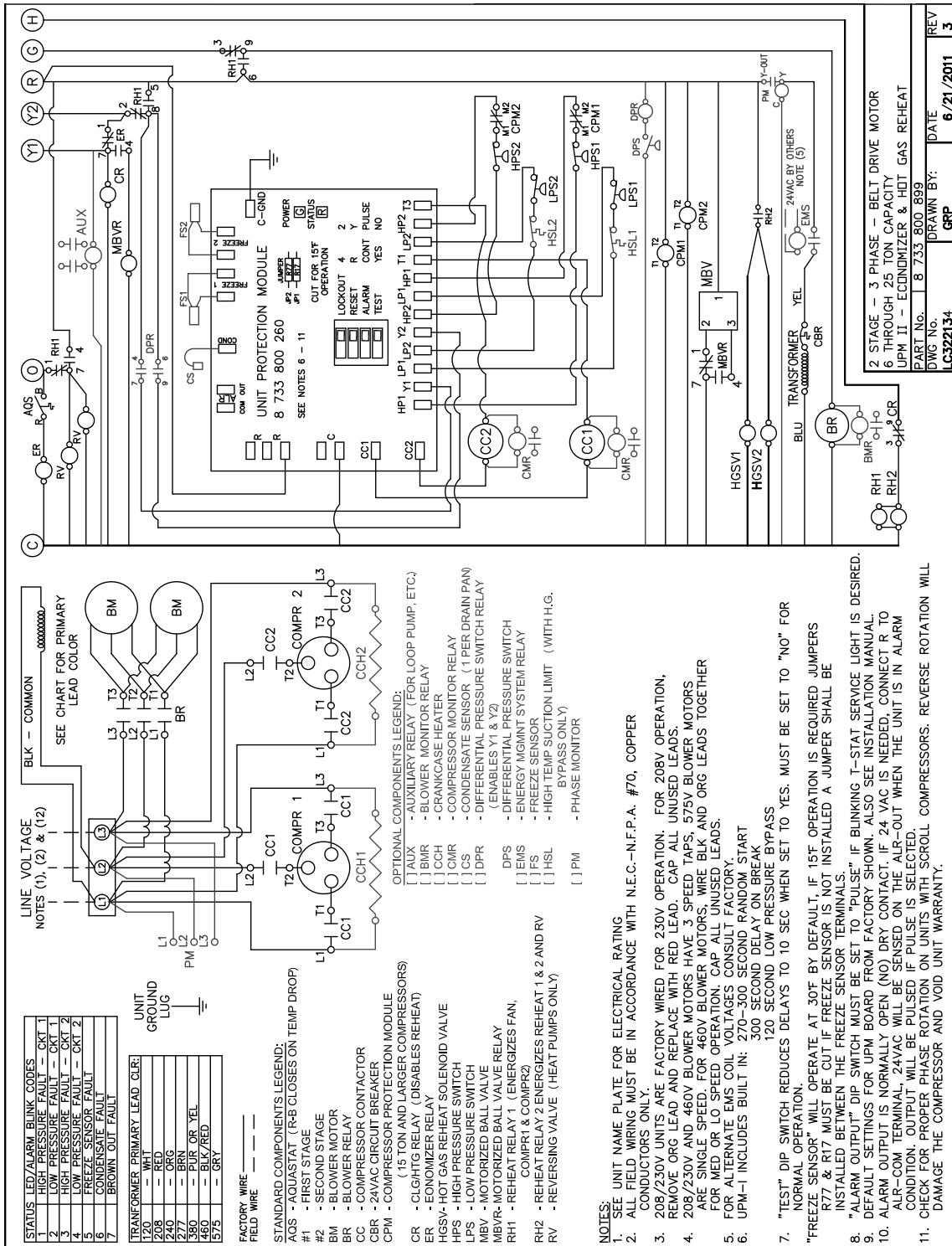

Figure # 19



FOR REFERENCE ONLY Actual unit wiring may vary from this example. Always refer to the wiring diagram attached to the unit.

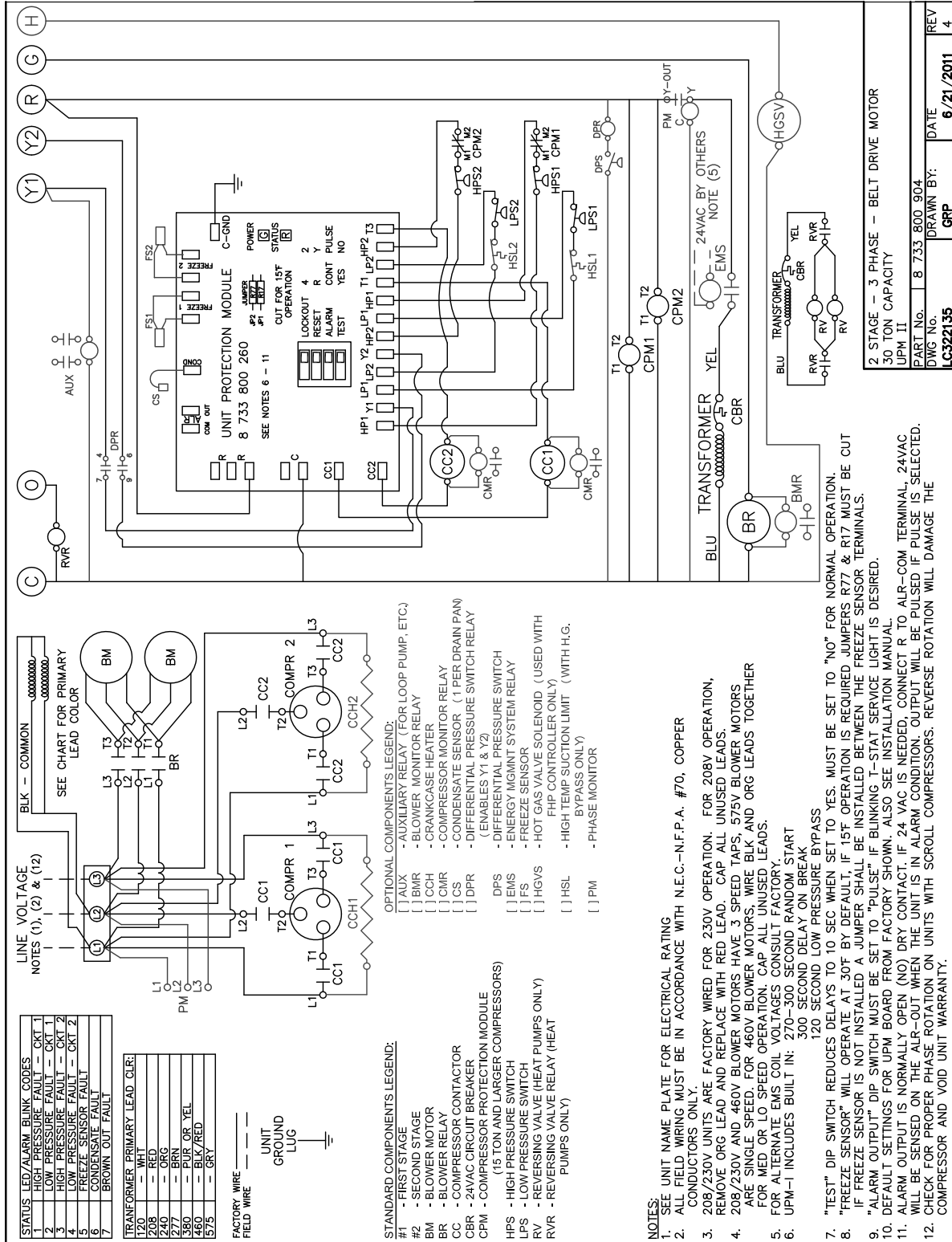

Figure # 20



FOR REFERENCE ONLY Actual unit wiring may vary from this example. Always refer to the wiring diagram attached to the unit.

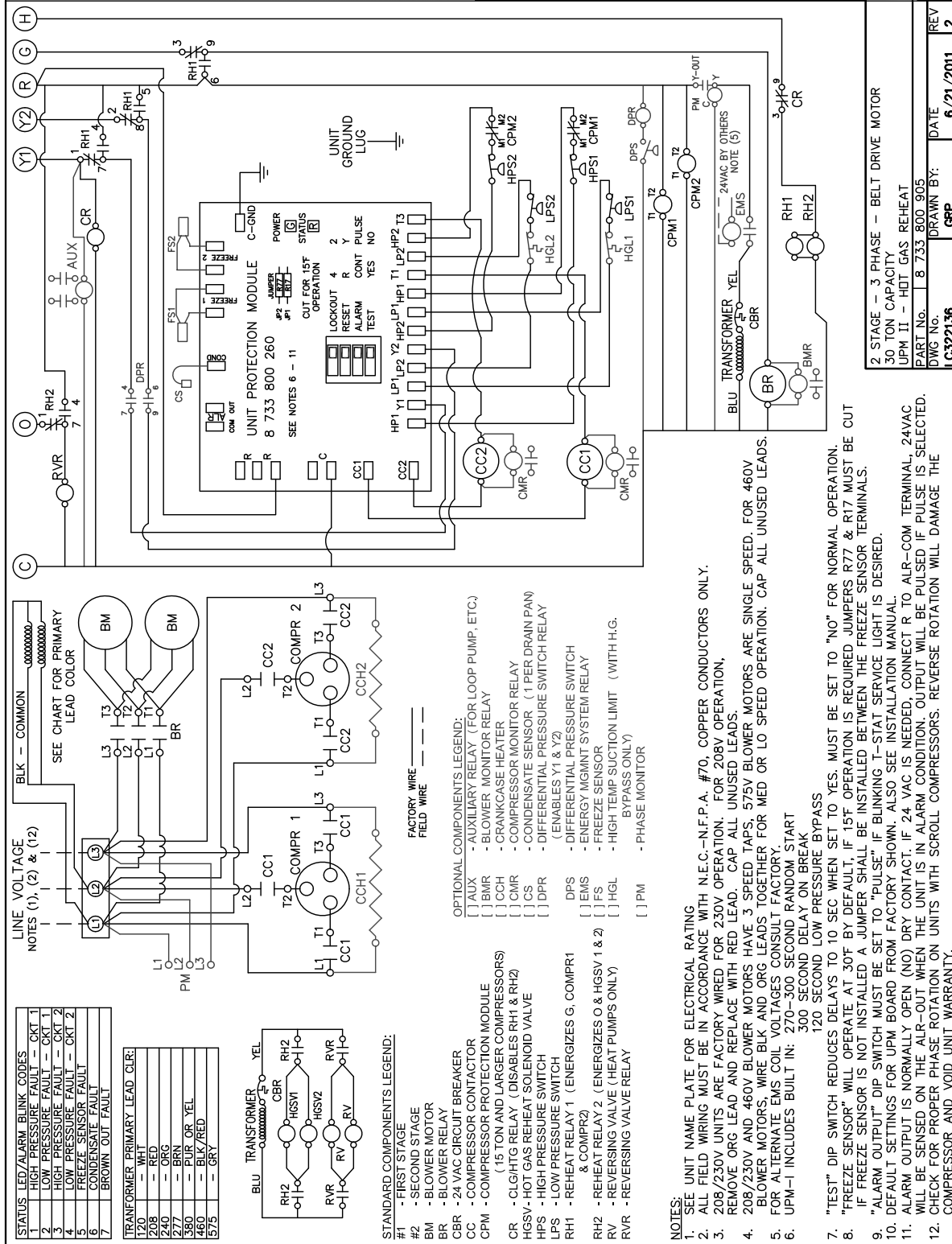

Figure # 21



FOR REFERENCE ONLY Actual unit wiring may vary from this example. Always refer to the wiring diagram attached to the unit.

2	STAGE - 3 PHASE - BELT DRIVE MOTOR
3	30 TON CAPACITY
4	UPM II - HOT GAS REHEAT
DWG No.	8 733 800 905
DRAWN BY:	GRP
DATE	6/21/2011
REV	2

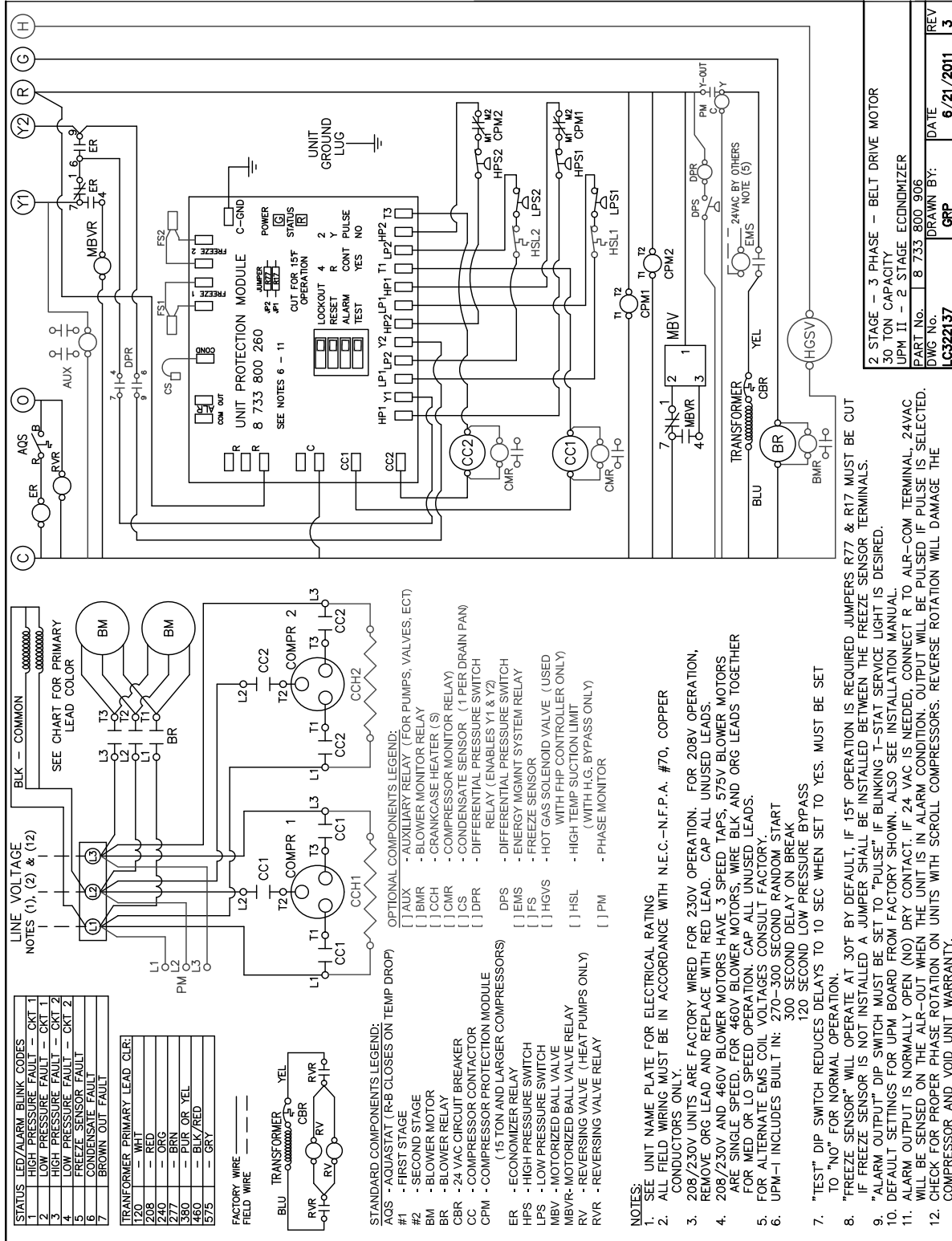

Figure # 22



FOR REFERENCE ONLY Actual unit wiring may vary from this example. Always refer to the wiring diagram attached to the unit.

2	STAGE - 3	PHASE - BELT DRIVE MOTOR
3	50	TON CAPACITY
UPM II	- 2	STAGE ECONOMIZER
PART No.	8 733 800 906	
DWG No.		
DATE	6/21/2011	
REV	3	

DRAWN BY: **GRP**

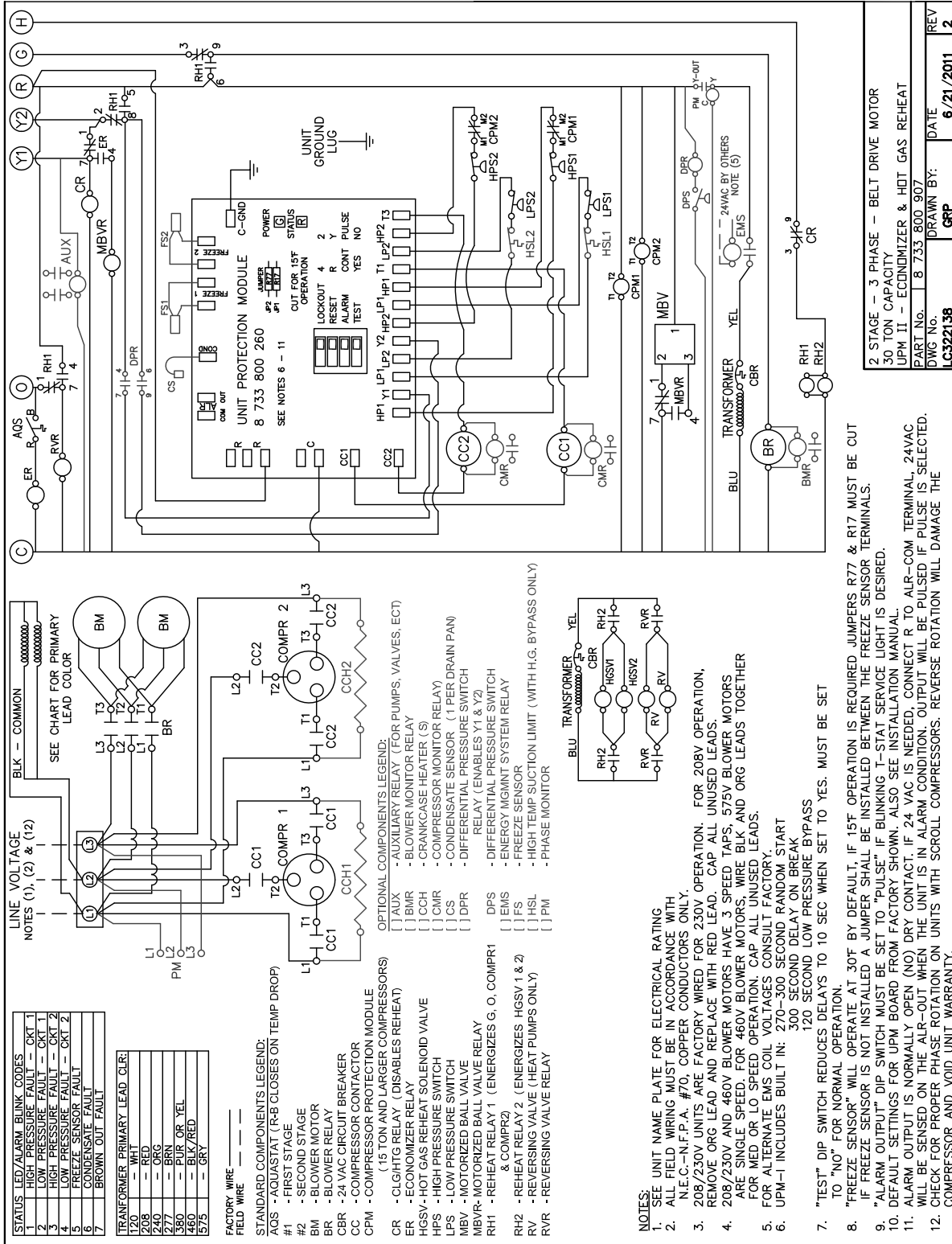

Figure # 23



FOR REFERENCE ONLY Actual unit wiring may vary from this example. Always refer to the wiring diagram attached to the unit.

2	STAGE - 3 PHASE - BELT DRIVE MOTOR
3	30 TON CAPACITY
4	UPM II - ECONOMIZER & HOT GAS REHEAT
PART No.	8 733 800 907
DWG No.	LC322138
DATE	6/21/2011
REV	2

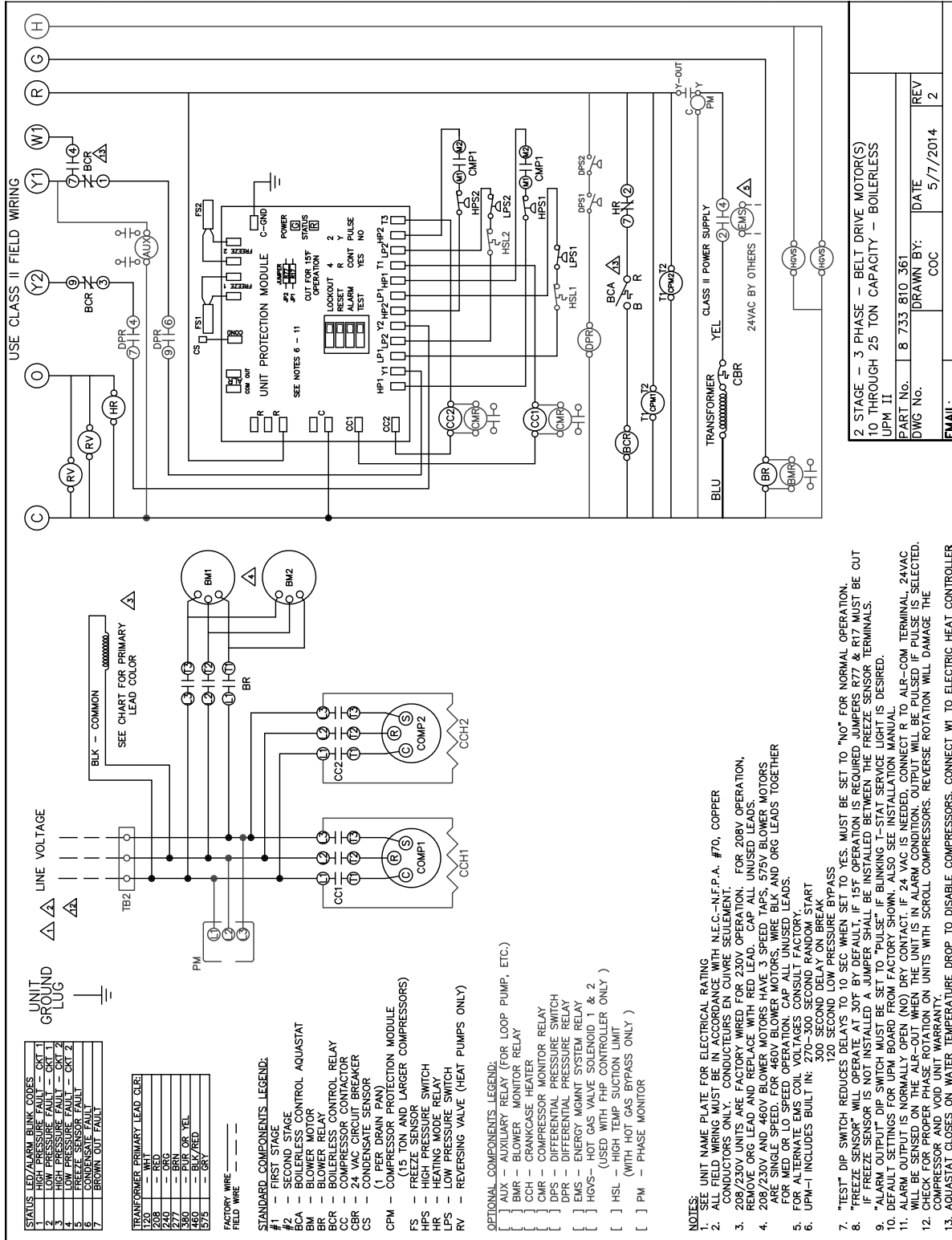

Figure # 24



FOR REFERENCE ONLY Actual unit wiring may vary from this example. Always refer to the wiring diagram attached to the unit.

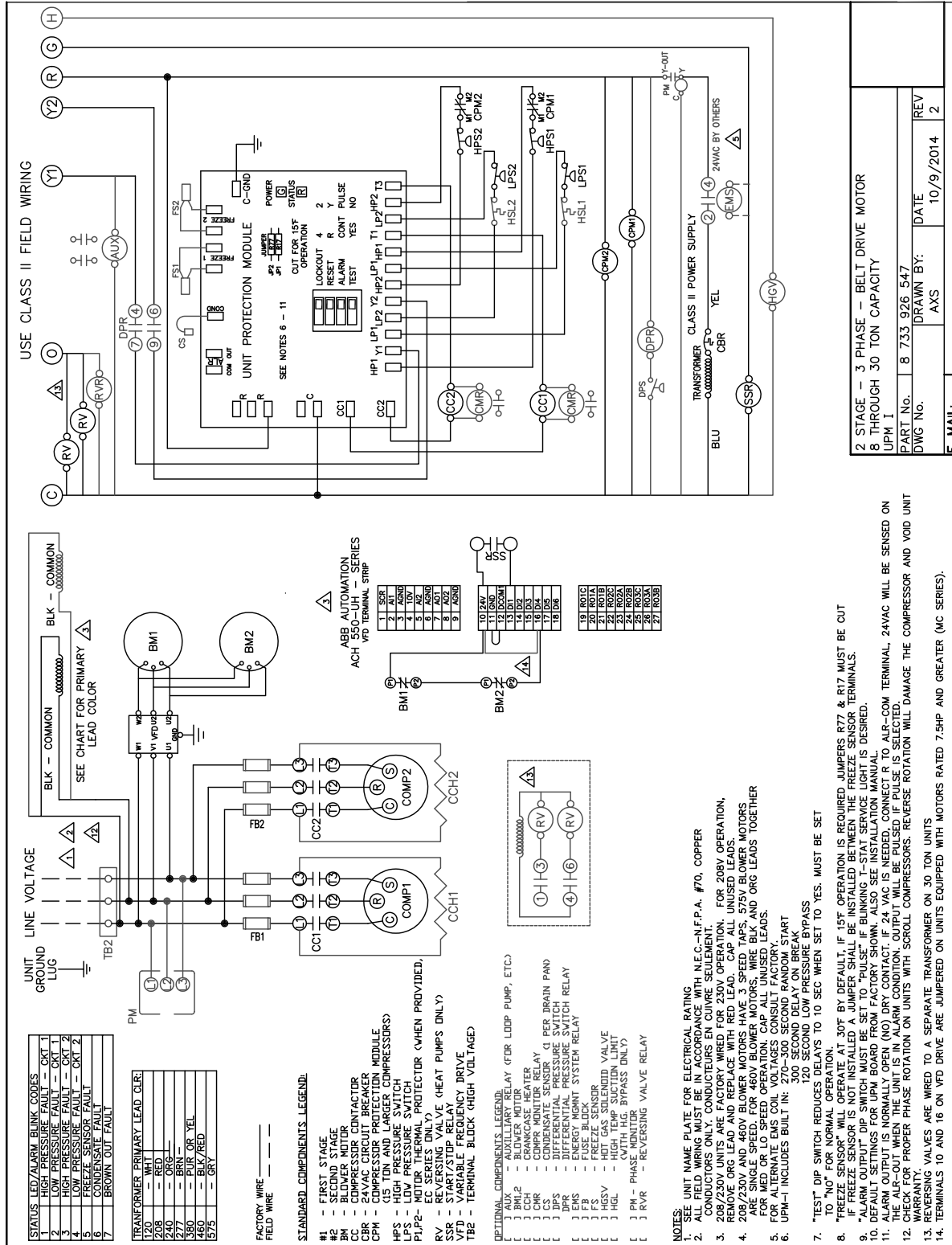

Figure # 25



FOR REFERENCE ONLY Actual unit wiring may vary from this example. Always refer to the wiring diagram attached to the unit.

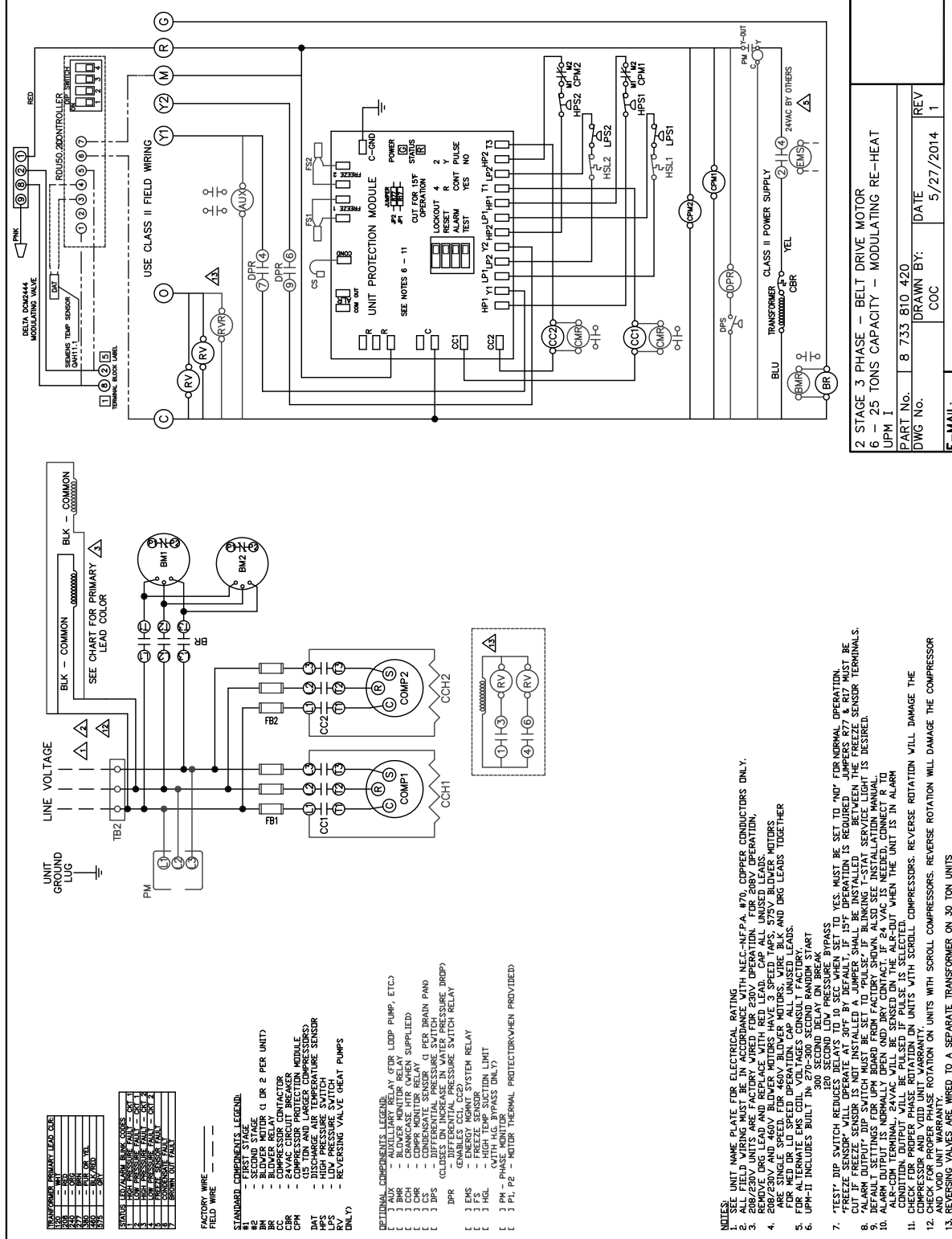

Figure # 26



FOR REFERENCE ONLY Actual unit wiring may vary from this example. Always refer to the wiring diagram attached to the unit.

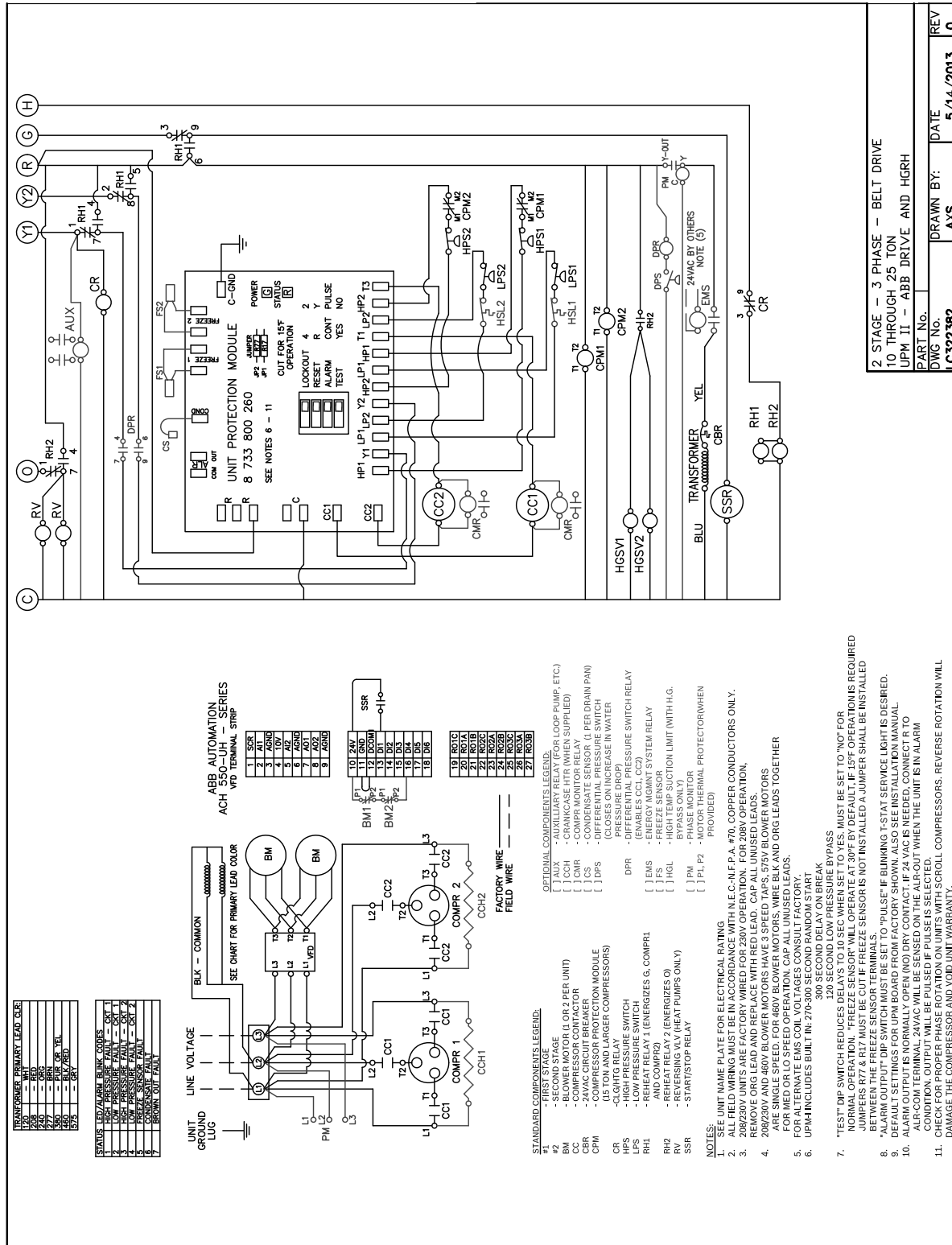

Figure # 27



FOR REFERENCE ONLY Actual unit wiring may vary from this example. Always refer to the wiring diagram attached to the unit.

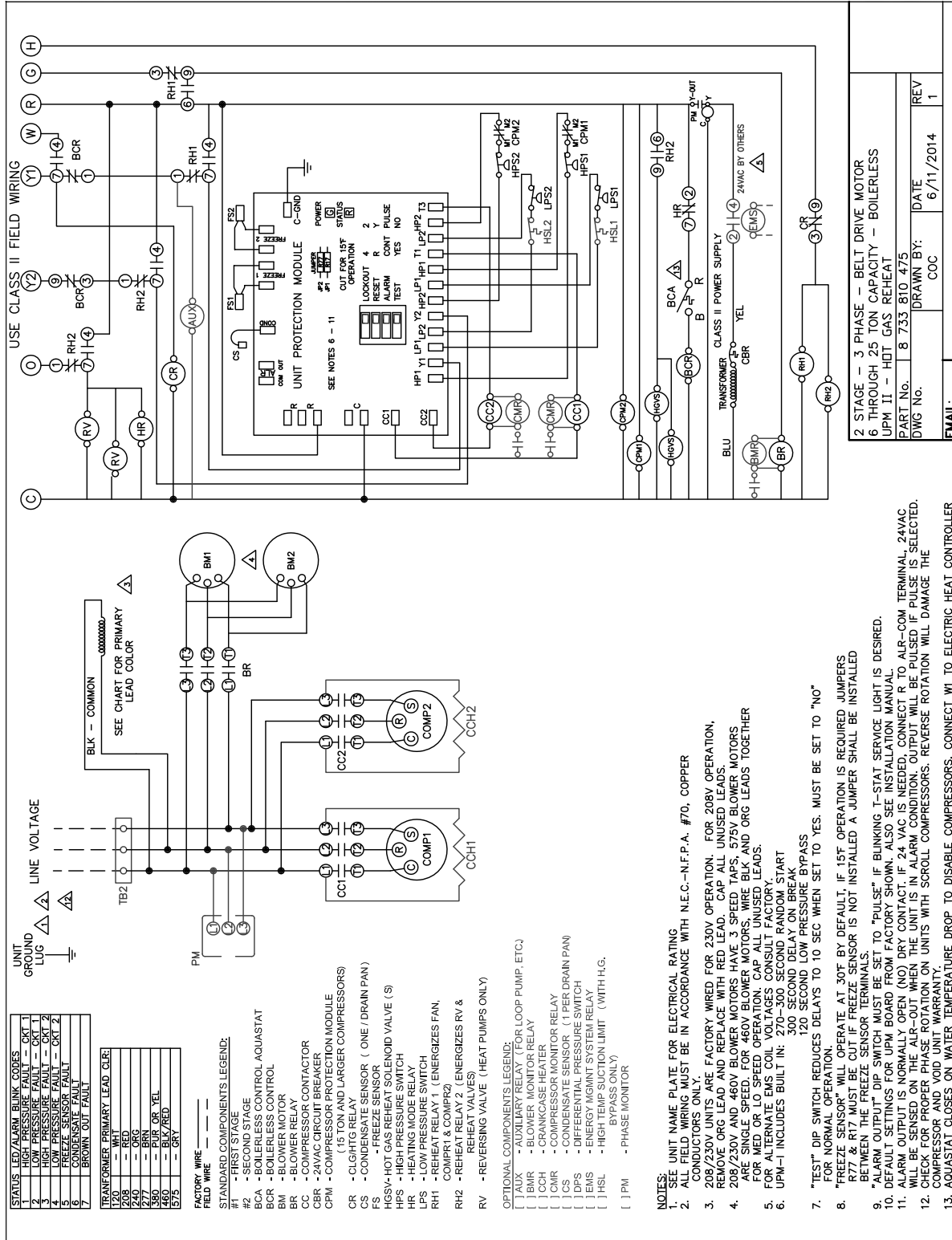

Figure # 28



FOR REFERENCE ONLY Actual unit wiring may vary from this example. Always refer to the wiring diagram attached to the unit.

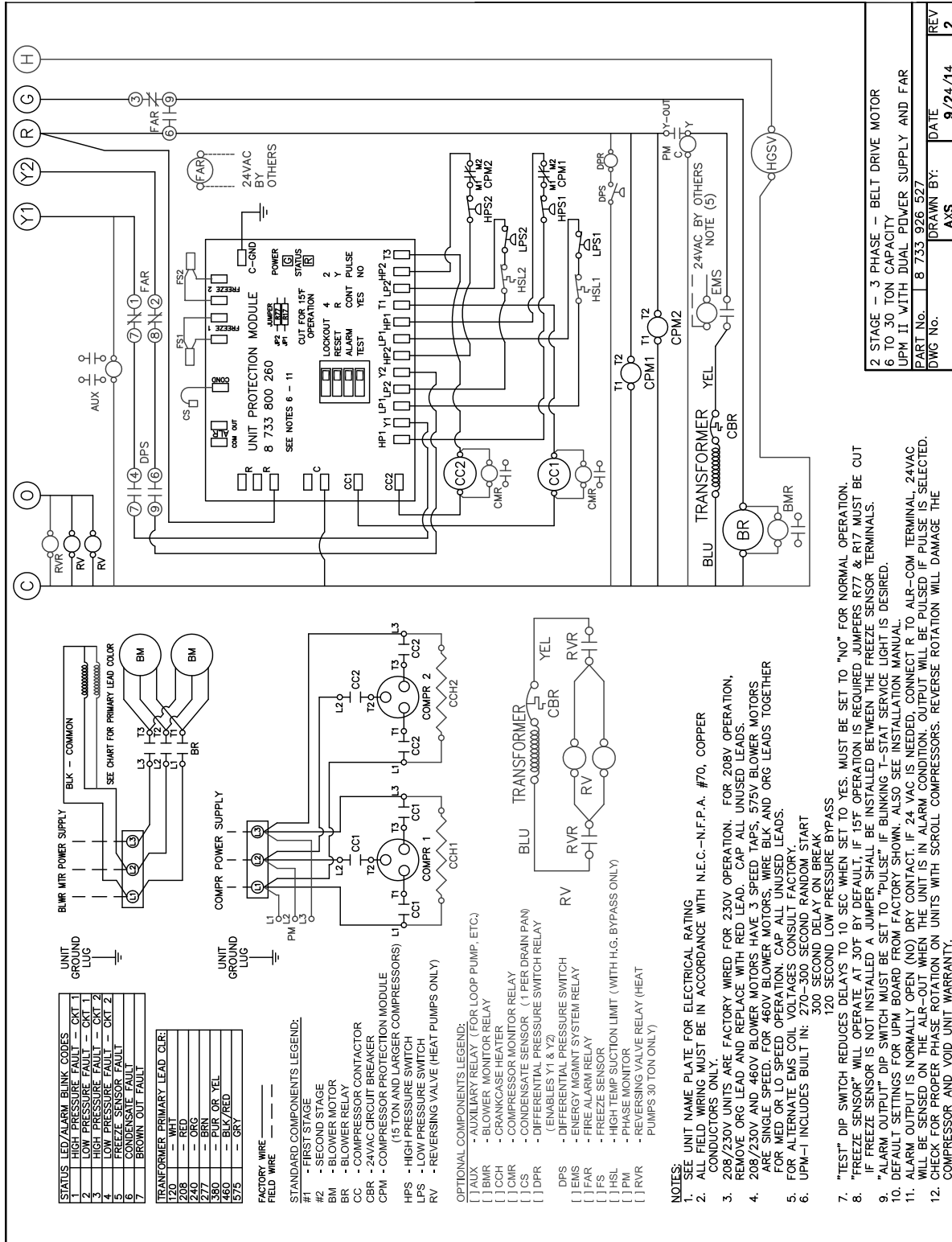

Figure # 29



FOR REFERENCE ONLY Actual unit wiring may vary from this example. Always refer to the wiring diagram attached to the unit.

2 STAGE - 3 PHASE - BELT DRIVE MOTOR	DATE	9/24/14
6 TO 30 TON CAPACITY	DRAWN BY:	AXS
UPM II WITH DUAL POWER SUPPLY AND FAR	PART No.	8 733 926 527
DWG No.	REV	2

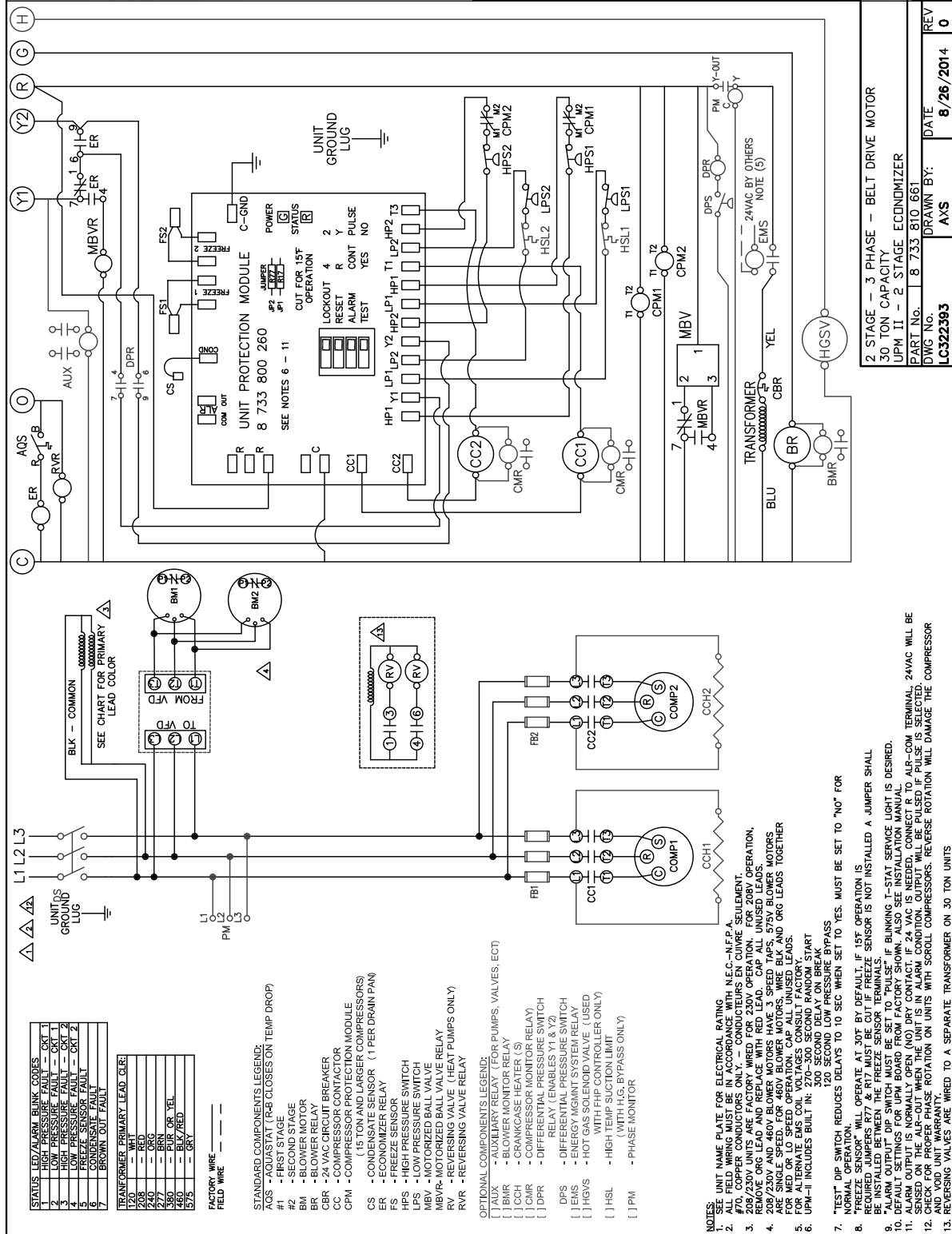

Figure # 30



FOR REFERENCE ONLY Actual unit wiring may vary from this example. Always refer to the wiring diagram attached to the unit.

NOTES

Bosch Thermotechnology Corp
555 NW 65th Court
Ft.Lauderdale, FL 33309
Phone: 954-776-5471 | Fax: 954-776-5529
www.bosch-climate-us
Revised: 01/2015

