



**TRANE®**

# Variable Speed Modular Multi-position Communicating Air Handlers 2-5 Tons

---

TAM8A0A24V21CA  
TAM8A0B30V21CA  
TAM8A0C36V31CA  
TAM8A0C42V31CA  
TAM8A0C48V41CA  
TAM8A0C60V51CA

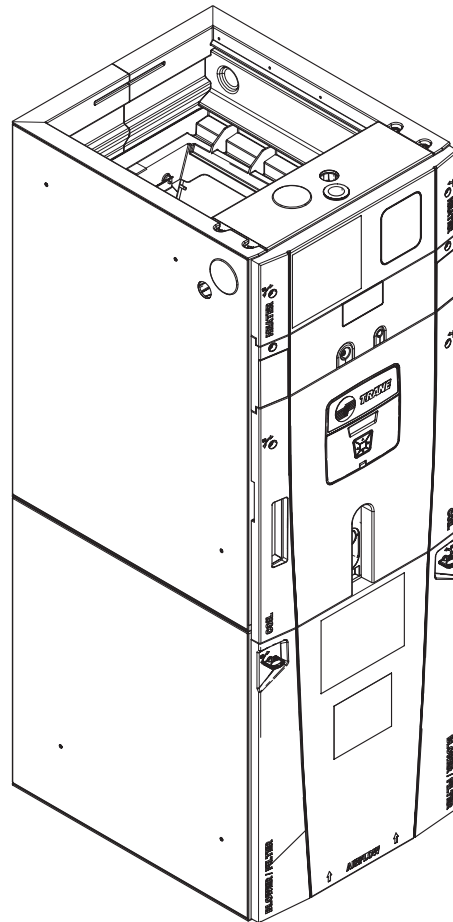

---

**PUB. NO. 22-1856-02**



# Features and Benefits

- **Air-Tite II™** cabinet
  - 2% or less air leakage
  - Precision applied - durable door seals
  - Specially designed air seal around refrigerant, condensate and conduit connections
  - Double wall foamed cabinet system
  - $\geq$  R-4.2 insulating value (Avg. insulating value R-8.2)
  - No loose fiber design
  - Smooth cleanable interior design
  - Sweat eliminating design
  - Composite foamed cabinet doors
  - Water proof cabinet design
  - Integrated horizontal drain pans
  - Modular cabinet with 5/16" allen wrench "quick latch" design
- Multi-position up/down flow horizontal left/right
- 3 Wire communication
- Display Assembly with enhanced diagnostic information and setup capability
- Status Mode scrolling on Display Assembly
- Side return option (sold as accessory)
- Control board protection pocket built into cabinet wall
- Alert port to view control board codes without door removal
- Alert code notification
- Low voltage terminal connection point
- Quarter turn fasteners on blower/filter door
- **Vortica®** blower with polarized plug connections and integrated slide deck for easy removal
- Aluminum coil with integrated slide deck for easy removal and polarized plug connections on coil EEV
- Patented enhanced coil fin
- Electronic Expansion Valve (EEV) with low ambient and low superheat compressor protection
- Dual refrigerant compatible as shipped
- Slide in electric heaters with polarized plug connections (sold as accessory)
- Slide in hot water coils with polarized plug connections (sold as accessory)
- UVC light kit with safety switch and polarized plug connections (sold as accessory)
- Labeled panels and connections
- Molded in 1" standard filter rail
- Variable speed ECM motor
- Soft start fan motor operation
- **Comfort R™** mode
- Built in fan delay modes
- Maximum width of 23.5"
- Compact 20.8" depth with doors removed
- Two tone color
- Fused 24v power
- Safety door switch
- **1-year warranty**
- **10-year warranty registered**
- **Optional extended warranty available**

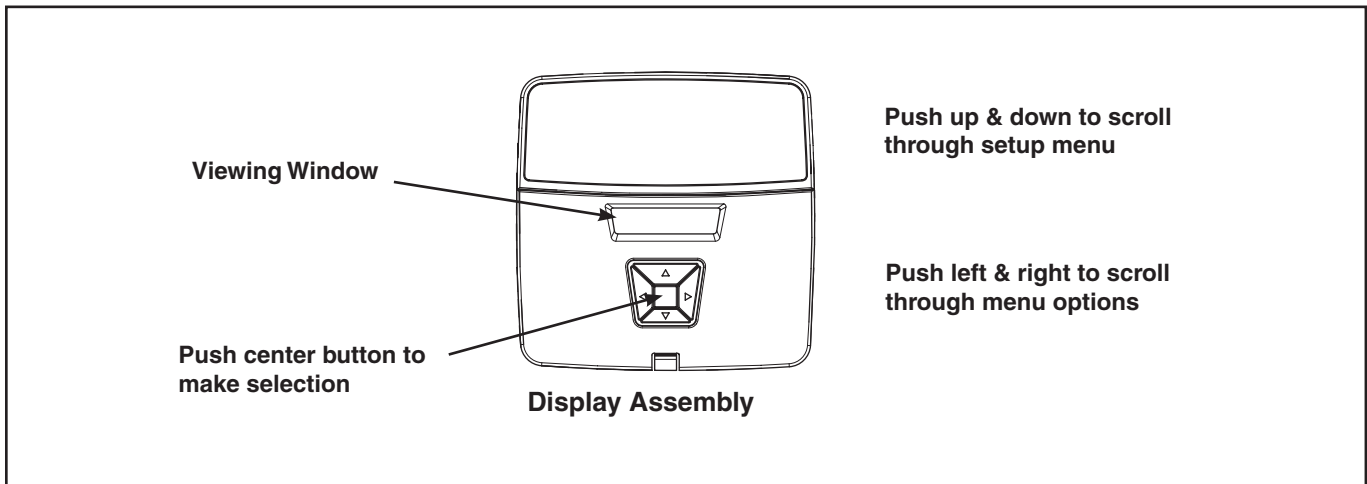



# Contents

---

<b>Features and Benefits</b>	<b>2</b>
Optional Equipment	<b>4</b>
<b>“Air-Tite II™” Features and Benefits</b>	<b>5</b>
<b>General Data</b>	<b>6</b>
TAM8A0A24V21CA	<b>6</b>
TAM8A0B30V21CA	<b>6</b>
TAM8A0C36V31CA	<b>6</b>
TAM8A0C42V31CA	<b>6</b>
TAM8A0C48V41CA	<b>6</b>
TAM8A0C60V51CA	<b>6</b>
<b>Performance Data</b>	<b>7</b>
<b>Electrical Data</b>	<b>19</b>
<b>Field Wiring</b>	<b>26</b>
<b>Convertibility</b>	<b>30</b>
<b>Dimensions</b>	<b>31</b>



# Optional Equipment

## OPTIONAL EQUIPMENT FOR AIR HANDLERS

Accessory Number	Description	Fits Cabinet Size
BAYEVAC05BK1AA	Electric Heater, 5kW, Breaker, RS-485 Control, 1 Ph	A to C
BAYEVAC05LG1AA	Electric Heater, 5kW, Lugs, RS-485 Control, 1 Ph	A to C
BAYEVAC08BK1AA	Electric Heater, 8kW, Breaker, RS-485 Control, 1 Ph	A to C
BAYEVAC08LG1AA	Electric Heater, 8kW, Lugs, RS-485 Control, 1 Ph	A to C
BAYEVAC10BK1AA	Electric Heater, 10kW, Breaker, RS-485 Control, 1 Ph	A to C
BAYEVAC10LG1AA	Electric Heater, 10kW, Lugs, RS-485 Control, 1 Ph	A to C
BAYEVBC15BK1AA	Electric Heater, 15kW, Breaker, RS-485 Control, 1 Ph	B to C
BAYEVBC20BK1AA	Electric Heater, 20kW, Breaker, RS-485 Control, 1 Ph	B to C
BAYEVCC25BK1AA	Electric Heater, 25kW, Breaker, RS-485 Control, 1 Ph	C
BAYEVAC10LG3AA	Electric Heater, 10kW, Lugs, RS-485 Control, 3 Ph	A to C
BAYEVBC15LG3AA	Electric Heater, 15kW, Lugs, RS-485 Control, 3 Ph	B to C
BAYSUPFLGAA	Supply Duct Flange A	A
BAYSUPFLGBA	Supply Duct Flange B	B
BAYSUPFLGCA	Supply Duct Flange C	C
BAYRETFLGAA	Return Duct Flange A	A
BAYRETFLGB	Return Duct Flange B	B
BAYRETFLGCA	Return Duct Flange C	C
TASB175	Plenum Stand A	A
TASB215	Plenum Stand B	B
TASB235	Plenum Stand C	C
BAYSRKIT100A	Side Return Kit	A to C
BAYICSKIT01A	Internal Condensate Switch Kit	A to C
BAYHHKIT001A	Horizontal Hanger Kit	A to C
BAYUVCLK001A	UVC Lights	A to C
BAYLVKIT100A	Low Voltage Conduit Entry Kit	A to C
BAYSPEKT200A	Single Power Entry Kit	A to C
BAYWVAA05SC1AA*	Hydronic Coil - 50,000 BTUH - Slide-in, RS-485 Control	A
BAYWVBB07SC1AA*	Hydronic Coil - 70,000 BTUH - Slide-in, RS-485 Control	B
BAYWVCC08SC1AA*	Hydronic Coil - 80,000 BTUH - Slide-in, RS-485 Control	C
BAYWACC11SC1AA*	Hydronic Coil - 110,000 BTUH - Add-on, No Control	C
BAYWVBRD485	RS-485 Control for BAYWACC11SC1AA	C
BAYCC24VK01A	Compressor Module Kit	A to C

\* The TCONT900 thermostat cannot be used with a Hydronic Coil

# “Air-Tite II™” Features and Benefits

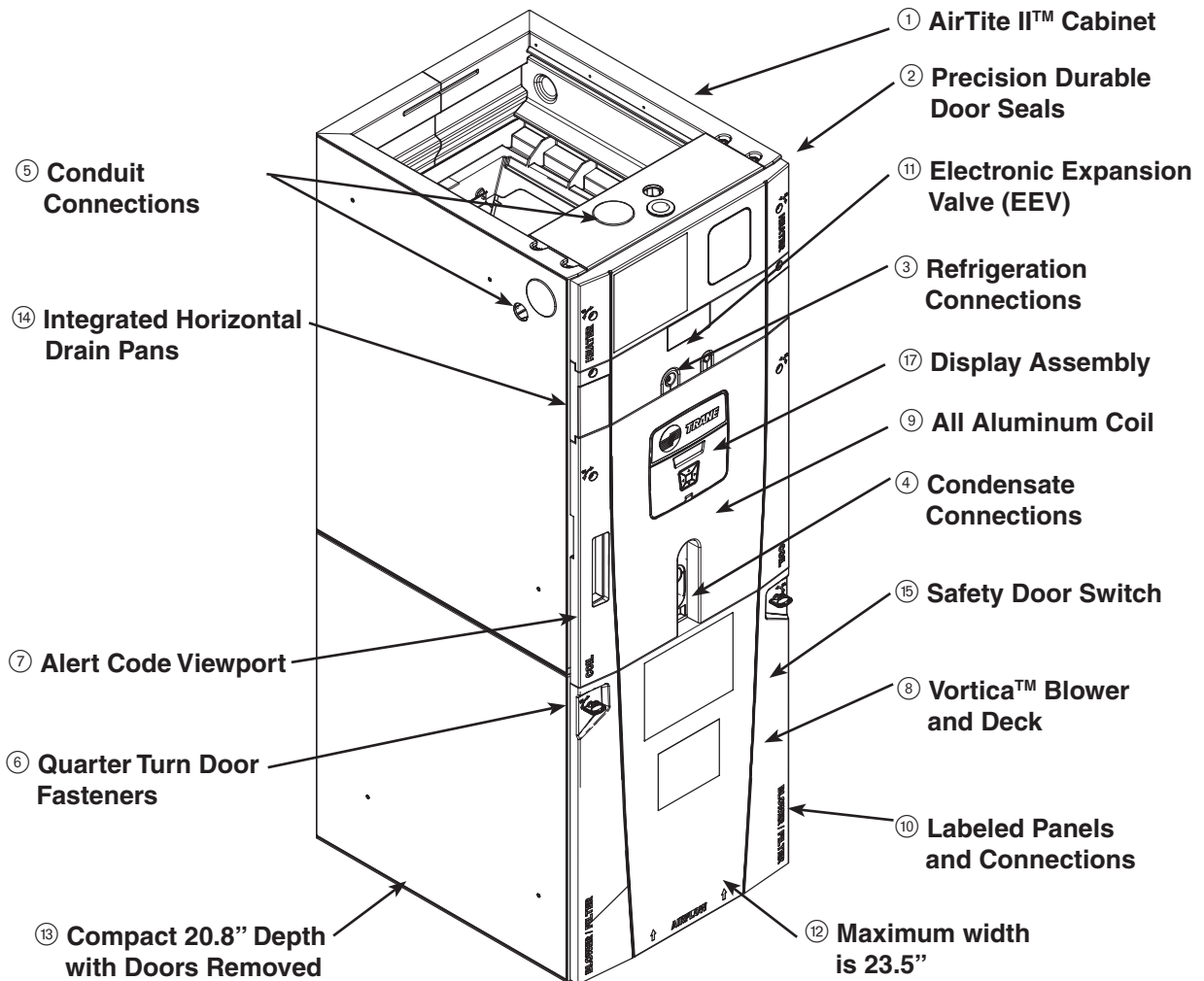

① **AirTite II™ Cabinet**

- Double wall foamed cabinet system
- Waterproof Cabinet Design
- ≥ R-4.2 Insulating Value (Avg. insulating value R-8.2)
- Composite Foamed Cabinet Doors
- Sweat Eliminating Cabinet Design
- Loose Fiber Eliminating Design
- Smooth Cleanable Cabinet Design

② **Precision Durable Door Seals**

③ **Refrigeration Connections**

④ **Condensate Connections**

- ⑤ **Conduit Connections** - Conduit Connections on Left, Right, and Top

⑥ **Quarter Turn Fasteners on Blower/Filter Door**

⑦ **Alert Code Viewport**

- Alert Codes can be Viewed Without Door Removal
- Control Protection Pocket

- ⑧ **Vortica™ Blower and Deck** - Polarized Plug on Blower

⑨ **All Aluminum Coil**

- Integrated Slide Deck for Easy Removal
- Polarized Plug connections on Coil EEV
- Patented Enhanced Coil Fin

⑩ **Labeled Panels and Connections**

⑪ **Electronic Expansion Valve (EEV)**

- Low Ambient and Low Superheat Protection
- Dual Refrigerant Compatible as Shipped

⑫ **Maximum width is 23.5”**

⑬ **Compact 20.8” Depth with Doors Removed**

⑭ **Integrated Horizontal Drain Pans**

⑮ **Safety Door Switch** - Fused 24V Power

⑯ **5/16” Allen Wrench “Quick Latch” Modular Cabinet**

⑰ **Display Assembly**

- Display Assembly with enhanced diagnostic information and setup capability
- Status Mode scrolling on Display Assembly



**TRANE®**

# General Data

## PRODUCT SPECIFICATIONS

MODEL	TAM8A0A24V21CA	TAM8A0B30V21CA	TAM8A0C36V31CA
<b>RATED VOLTS/PH/HZ.</b>	200-230/1/60	200-230/1/60	200-230/1/60
<b>RATINGS</b> ①	See O.D. Specifications	See O.D. Specifications	See O.D. Specifications
<b>INDOOR COIL — Type</b>	Plate Fin	Plate Fin	Plate Fin
Rows — F.P.I.	3 - 14	3 - 14	3 - 14
Face Area (sq. ft.)	3.67	5.04	5.50
Tube Size (in.)	3/8	3/8	3/8
Refrigerant Control	EEV	EEV	EEV
Drain Conn. Size (in.) ②	3/4 NPT	3/4 NPT	3/4 NPT
<b>DUCT CONNECTIONS</b>	See Outline Drawing	See Outline Drawing	See Outline Drawing
<b>INDOOR FAN — Type</b>	Centrifugal	Centrifugal	Centrifugal
Diameter-Width (In.)	11 X 8	11 X 10	11 X 10
No. Used	1	1	1
Drive - No. Speeds	Direct - Variable	Direct - Variable	Direct - Variable
CFM vs. in. w.g.	See Fan Performance Table	See Fan Performance Table	See Fan Performance Table
No. Motors — H.P.	1 - 1/2	1 - 1/2	1 - 1/2
Motor Speed R.P.M.	Variable ECM	Variable ECM	Variable ECM
Volts/Ph/Hz	208-230/1/60	208-230/1/60	208-230/1/60
F.L. Amps	3.0	3.0	3.0
<b>FILTER</b>			
Filter Furnished?	No	No	No
Type Recommended	Throwaway	Throwaway	Throwaway
No.-Size-Thickness	1 - 16 X 20 - 1 in.	1 - 20 X 20 - 1 in.	1 - 22 X 20 - 1 in.
<b>REFRIGERANT</b>	<b>R-410A</b>	<b>R-410A</b>	<b>R-410A</b>
Ref. Line Connections	Brazed	Brazed	Brazed
Coupling or Conn. Size — in. Gas	3/4	3/4	7/8
Coupling or Conn. Size — in. Liq.	3/8	3/8	3/8
<b>DIMENSIONS</b>	H x W x D	H x W x D	H x W x D
Crated (In.)	51 x 20 x 24.5	56.8 x 23.5 x 24.5	58 x 25.5 x 24.5
Uncrated	49.9 x 17.5 x 21.8	55.7 x 21.3 x 21.8	56.9 x 23.5 x 21.8
<b>WEIGHT</b>			
Shipping (Lbs.)/Net (Lbs.)	126/116	150/138	157/146

## PRODUCT SPECIFICATIONS

MODEL	TAM8A0C42V31CA	TAM8A0C48V41CA	TAM8A0C60V51CA
<b>RATED VOLTS/PH/HZ.</b>	200-230/1/60	200-230/1/60	200-230/1/60
<b>RATINGS</b> ①	See O.D. Specifications	See O.D. Specifications	See O.D. Specifications
<b>INDOOR COIL — Type</b>	Plate Fin	Plate Fin	Plate Fin
Rows — F.P.I.	4 - 14	4 - 14	4 - 14
Face Area (sq. ft.)	5.04	5.96	5.96
Tube (in.)	3/8	3/8	3/8
Refrigerant Control	EEV	EEV	EEV
Drain Conn. Size (in.) ②	3/4 NPT	3/4 NPT	3/4 NPT
<b>DUCT CONNECTIONS</b>	See Outline Drawing	See Outline Drawing	See Outline Drawing
<b>INDOOR FAN — Type</b>	Centrifugal	Centrifugal	Centrifugal
Diameter-Width (In.)	11 X 10	11 X 10	11 X 10
No. Used	1	1	1
Drive - No. Speeds	Direct - Variable	Direct - Variable	Direct - Variable
CFM vs. in. w.g.	See Fan Performance Table	See Fan Performance Table	See Fan Performance Table
No. Motors — H.P.	1 - 1/2	1 - 3/4	1 - 1
Motor Speed R.P.M.	Variable ECM	Variable ECM	Variable ECM
Volts/Ph/Hz	208-230/1/60	208-230/1/60	208-230/1/60
F.L. Amps	3.0	4.2	5.5
<b>FILTER</b>			
Filter Furnished?	No	No	No
Type Recommended	Throwaway	Throwaway	Throwaway
No.-Size-Thickness	1 - 22 X 20 - 1 in.	1 - 22 X 20 - 1 in.	1 - 22 X 20 - 1 in.
<b>REFRIGERANT</b>	<b>R-410A</b>	<b>R-410A</b>	<b>R-410A</b>
Ref. Line Connections	Brazed	Brazed	Brazed
Coupling or Conn. Size — in. Gas	7/8	7/8	7/8
Coupling or Conn. Size — in. Liq.	3/8	3/8	3/8
<b>DIMENSIONS</b>	H x W x D	H x W x D	H x W x D
Crated (In.)	58 x 25.5 x 24.5	62.8 x 25.5 x 24.5	62.8 x 25.5 x 24.5
Uncrated	56.9 x 23.5 x 21.8	61.7 x 23.5 x 21.8	61.7 x 23.5 x 21.8
<b>WEIGHT</b>			
Shipping (Lbs.)/Net (Lbs.)	162/150	174/162	175/163

① These Air Handlers are AHRI. certified with various Split System Air Conditioners and Heat Pumps (AHRI STANDARD 210/240). Refer to the Split System Outdoor Unit Product Data Guides for performance data.

② 3/4" Male Plastic Pipe (Ref.: ASTM 1785-76)

*AM8A0A24 AIRFLOW PERFORMANCE CONSTANT CFM MODE / CONSTANT TORQUE MODE														
OUTDOOR MULTIPLIER (TONS)	COOLING AIRFLOW SETTING	Airflow Power	EXTERNAL STATIC PRESSURE (Constant CFM / Constant Torque)			HEATING AIRFLOW SETTING	Airflow Power	EXTERNAL STATIC PRESSURE						
			0.1	0.3	0.5			0.7	0.9	0.1	0.3	0.5	0.7	
1.5 tons	290 CFM/ton	CFM Watts	419 / 554 22 / 40	431 / 412 50 / 48	408 / NA 77 / NA	339 / NA 102 / NA	279 / NA 133 / NA	290 CFM/ton	CFM Watts	416 22	425 49	400 76	329 101	291 134
	350 CFM/ton	CFM Watts	534 / 638 37 / 56	555 / 541 70 / 67	548 / 373 102 / 73	514 / NA 131 / NA	439 / NA 154 / NA	350 CFM/ton	CFM Watts	532 37	550 69	542 101	507 129	434 152
	400 CFM/ton	CFM Watts	617 / 705 52 / 71	639 / 626 88 / 85	636 / 513 123 / 96	612 / 325 155 / 101	559 / NA 181 / NA	430 CFM/ton	CFM Watts	660 62	680 99	679 136	658 169	614 197
	450 CFM/ton	CFM Watts	692 / 770 69 / 89	714 / 703 108 / 105	714 / 613 146 / 119	694 / 494 181 / 128	653 / NA 209 / NA	450 CFM/ton	CFM Watts	690 69	710 108	709 145	690 180	650 208
	290 CFM/ton	CFM Watts	595 / 688 48 / 67	617 / 605 83 / 80	614 / 481 117 / 90	588 / 241 149 / 95	531 / NA 174 / NA	290 CFM/ton	CFM Watts	593 48	613 82	608 116	582 147	527 172
2 tons †	350 CFM/ton	CFM Watts	716 / 792 136 / 161	737 / 727 115 / 112	738 / 643 154 / 127	720 / 534 190 / 137	681 / 383 219 / 145	350 CFM/ton	CFM Watts	714 75	734 115	734 153	716 189	679 218
	400 † CFM/ton	CFM Watts	809 / 877 103 / 125	829 / 821 147 / 144	832 / 751 190 / 161	818 / 666 228 / 174	787 / 561 261 / 183	430 † CFM/ton	CFM Watts	862 122	881 168	884 213	874 254	849 290
	450 CFM/ton	CFM Watts	900 / 964 127 / 158	920 / 913 175 / 178	924 / 852 231 / 200	913 / 777 274 / 214	888 / 689 310 / 225	450 CFM/ton	CFM Watts	899 136	917 184	921 231	912 273	889 310
	290 CFM/ton	CFM Watts	740 / 829 81 / 108	761 / 769 123 / 125	762 / 692 163 / 141	745 / 596 199 / 153	709 / 473 229 / 162	290 CFM/ton	CFM Watts	738 81	757 122	758 162	742 198	707 229
	350 CFM/ton	CFM Watts	878 / 957 127 / 158	897 / 907 175 / 178	901 / 845 220 / 196	890 / 770 262 / 211	863 / 680 297 / 221	350 CFM/ton	CFM Watts	876 127	895 174	898 220	888 261	864 297
2.5 tons	400 CFM/ton	CFM Watts	993 / 1070 178 / 215	1012 / 1023 231 / 236	1017 / 967 281 / 255	1009 / 901 327 / 270	989 / 821 367 / 280	430 CFM/ton	CFM Watts	1064 215	1083 272	1089 326	1084 375	1066 418
	450 CFM/ton	CFM Watts	1115 / 1193 244 / 290	1133 / 1148 304 / 312	1139 / 1095 359 / 330	1132 / 1034 409 / 345	1113 / 961 451 / 354	450 CFM/ton	CFM Watts	1115 244	1133 304	1139 360	1133 410	1116 453
	290 CFM/ton	CFM Watts	873 / 953 125 / 156	893 / 902 173 / 176	896 / 840 218 / 194	885 / 764 259 / 209	858 / 674 295 / 219	290 CFM/ton	CFM Watts	871 125	890 172	894 217	883 259	859 295
	350 CFM/ton	CFM Watts	1041 / 1118 202 / 242	1059 / 1072 257 / 264	1065 / 1018 310 / 282	1058 / 953 358 / 297	1039 / 877 399 / 307	350 CFM/ton	CFM Watts	1040 202	1058 257	1064 310	1059 358	1041 401
	400 CFM/ton	CFM Watts	1194 / 1271 295 / 347	1210 / 1227 358 / 368	1214 / 1175 415 / 386	1205 / 1115 465 / 399	1154 / 1046 485 / 408	430 CFM/ton	CFM Watts	1291 368	1302 432	1300 487	1220 478	1138 470
3 tons	450 CFM/ton	CFM Watts	1355 / 1421 422 / 476	1360 / 1373 483 / 491	1284 / 1284 476 / 476	1203 / 1203 469 / 469	1120 / 1120 464 / 464	450 CFM/ton	CFM Watts	1355 422	1360 483	1286 476	1208 468	1128 462

NOTES:

- \* Models start with "A" or "T"
- † Factory Setting
- Status LED will blink once per 100 CFM requested. In torque mode, actual airflow may be lower.

- Torque mode will reduce airflow when static is above approximately 0.3" water column.
- All heating modes default to Constant CFM.
- Cooling airflow values are with wet coil, no filter

### AM8A0A24 Minimum Heating Airflow Settings

MINIMUM HEATER AIRFLOW CFM - HEATER MATRIX			
BAYEAC08BK1AA	BAYEAC08BK1AA	BAYEAC10LG3AA	BAYEVCB15LG3AA
BAYEAC08L1AA	BAYEAC08L1AA	BAYEAC10LG3AA	BAYEVCB15BK1AA
BAYEAC08L1AA	BAYEAC08L1AA	600/713	BAYEVCB20BK1AA
BAYEAC08L1AA	BAYEAC08L1AA	630/900	
WITHOUT HEAT PUMP / WITH HP SEE AIR HANDLER NAMEPLATE			

NOTE: Minimum auxiliary heating airflow is automatically configured by the air handler model and the auxiliary heater model number. This is not field adjustable.

**\*AM8A0B30 AIRFLOW PERFORMANCE  
CONSTANT CFM MODE / CONSTANT TORQUE MODE**

OUTDOOR MULTIPLIER (TONS)	COOLING AIRFLOW SETTING		EXTERNAL STATIC PRESSURE (Constant CFM / Constant Torque)							HEATING AIRFLOW SETTING	Airflow Power	EXTERNAL STATIC PRESSURE						
	CFM/ton	Watts	0.1	0.3	0.5	0.7	0.9	CFM/ton	Watts			0.1	0.3	0.5	0.7	CFM/ton	Watts	
			290	438 / 406	388 / NA	338 / NA	279 / NA					290	485	437	393			350
1.5 tons	CFM/ton	Watts	21 / 30	44 / 42	69 / NA	97 / NA	130 / NA	290	CFM/ton	Watts	44	69	97	301				
	CFM/ton	Watts	29 / 39	56 / 54	85 / 60	115 / NA	146 / NA	350	CFM/ton	Watts	56	85	115	146				
	CFM/ton	Watts	37 / 48	67 / 65	99 / 72	132 / NA	164 / NA	430	CFM/ton	Watts	75	108	143	177				
	CFM/ton	Watts	45 / 59	80 / 77	115 / 86	151 / 91	186 / NA	450	CFM/ton	Watts	80	115	151	186				
2 tons †	CFM/ton	Watts	35 / 46	64 / 62	95 / 69	127 / NA	159 / NA	290	CFM/ton	Watts	64	95	127	160				
	CFM/ton	Watts	49 / 62	84 / 81	121 / 91	157 / 94	193 / NA	350	CFM/ton	Watts	84	120	157	193				
	CFM/ton	Watts	63 / 79	103 / 100	145 / 112	186 / 115	226 / NA	430 †	CFM/ton	Watts	116	161	205	248				
	CFM/ton	Watts	80 / 99	126 / 122	173 / 136	219 / 141	264 / 138	450	CFM/ton	Watts	126	172	219	263				
2.5 tons	CFM/ton	Watts	52 / 71	89 / 91	126 / 102	164 / 105	201 / NA	290	CFM/ton	Watts	88	126	164	201				
	CFM/ton	Watts	75 / 100	120 / 123	165 / 137	211 / 142	254 / 139	350	CFM/ton	Watts	120	165	210	254				
	CFM/ton	Watts	101 / 131	153 / 156	206 / 173	258 / 180	307 / 177	430	CFM/ton	Watts	176	234	290	342				
	CFM/ton	Watts	133 / 172	194 / 199	256 / 218	314 / 227	366 / 226	450	CFM/ton	Watts	194	255	314	366				
3 tons	CFM/ton	Watts	74 / 99	119 / 121	164 / 136	209 / 140	252 / 138	290	CFM/ton	Watts	118	164	208	252				
	CFM/ton	Watts	113 / 146	168 / 172	224 / 189	279 / 197	330 / 195	350	CFM/ton	Watts	168	224	279	330				
	CFM/ton	Watts	158 / 203	224 / 231	291 / 251	352 / 261	403 / 261	430	CFM/ton	Watts	267	337	398	446				
	CFM/ton	Watts	222 / 282	300 / 311	370 / 333	427 / 345	471 / 347	450	CFM/ton	Watts	299	369	427	472				

**NOTES:**

- \* Models start with "A" or "T"
- † Factory Setting
- Status LED will blink once per 100 CFM requested. In torque mode, actual airflow may be lower.
- Torque mode will reduce airflow when static is above approximately 0.35" water column.
- All heating modes default to Constant CFM.
- Cooling airflow values are with wet coil, no filter

**AM8A0B30 Minimum Heating Airflow Settings**

MODEL NO.	MINIMUM HEATER AIRFLOW CFM - HEATER MATRIX					
	BAYEVAC05BK1AA BAYEVAC05LG1AA 723/808	BAYEVAC08BK1AA BAYEVAC08LG1AA 723/1020	BAYEVAC10LG3AA 765/1020	BAYEVAC10LG3AA 680/808	BAYEVBC15BK1AA 765/1063	BAYEVBC15LG3AA 850/1105
*AM8A0B30V2ISAA						
	W/OUT HEAT PUMP / WITH HP SEE AIR HANDLER NAMEPLATE					

**NOTE:** Minimum auxiliary heating airflow is automatically configured by the air handler model and the auxiliary heater model number. This is not field adjustable.



*AM8A0C36 AIRFLOW PERFORMANCE												
CONSTANT CFM MODE / CONSTANT TORQUE MODE												
OUTDOOR MULTIPLIER (TONS)	COOLING AIRFLOW SETTING	Airflow Power	EXTERNAL STATIC PRESSURE (Constant CFM / Constant Torque)			HEATING AIRFLOW SETTING	Airflow Power	EXTERNAL STATIC PRESSURE				
			0.1	0.3	0.5			0.7	0.9	0.1	0.3	0.5
2 tons	290 CFM/ton	CFM Watts	610 / 758 30 / 47	573 / 573 57 / 58	556 / 321 86 / 62	553 / NA 119 / NA	290 CFM/ton	CFM Watts	574 58	557 87	551 119	551 153
	370 CFM/ton	CFM Watts	759 / 858 47 / 63	744 / 706 81 / 77	739 / 530 118 / 85	740 / 297 156 / 90	350 CFM/ton	CFM Watts	705 77	697 111	695 14	695 185
	400 CFM/ton	CFM Watts	812 / 974 54 / 85	803 / 846 92 / 103	802 / 707 132 / 115	803 / 554 172 / 122	420 CFM/ton	CFM Watts	843 102	843 144	844 186	845 277
	450 CFM/ton	CFM Watts	900 / 1024 69 / 96	899 / 903 112 / 116	902 / 774 156 / 129	906 / 636 201 / 137	450 CFM/ton	CFM Watts	900 72	903 159	906 204	908 248
	290 CFM/ton	CFM Watts	746 / 903 45 / 71	729 / 761 79 / 86	723 / 602 115 / 96	723 / 413 153 / 101	290 CFM/ton	CFM Watts	744 47	724 117	722 154	723 192
2.5 tons	370 CFM/ton	CFM Watts	923 / 905 73 / 97	927 / 776 117 / 116	931 / 639 209 / 138	935 / 488 254 / 143	350 CFM/ton	CFM Watts	876 110	878 153	880 196	882 239
	400 CFM/ton	CFM Watts	988 / 1175 86 / 137	944 / 1070 134 / 160	1001 / 961 184 / 177	1008 / 848 234 / 189	420 CFM/ton	CFM Watts	1046 152	1052 205	1060 257	1062 307
	450 CFM/ton	CFM Watts	1100 / 1243 112 / 159	1114 / 1143 168 / 183	1127 / 1040 225 / 202	1136 / 933 281 / 215	450 CFM/ton	CFM Watts	1116 175	1128 232	1137 288	1138 340
	290 CFM/ton	CFM Watts	874 / 1022 64 / 96	871 / 900 105 / 115	872 / 771 148 / 128	876 / 632 192 / 136	290 CFM/ton	CFM Watts	871 108	873 151	875 195	877 238
	370 † CFM/ton	CFM Watts	1087 / 1175 109 / 137	1099 / 1070 163 / 160	1112 / 961 220 / 177	1120 / 848 275 / 189	350 CFM/ton	CFM Watts	1043 152	1052 205	1060 257	1062 307
3 tons †	400 CFM/ton	CFM Watts	1170 / 1373 132 / 207	1188 / 1280 192 / 233	1202 / 1185 253 / 254	1212 / 1086 313 / 269	420 † CFM/ton	CFM Watts	1231 158	1253 289	1270 351	1270 405
	450 CFM/ton	CFM Watts	1322 / 1465 181 / 247	1344 / 1377 251 / 275	1360 / 1284 321 / 296	1364 / 1189 386 / 312	450 CFM/ton	CFM Watts	1324 192	1349 334	1365 397	1348 448
	290 CFM/ton	CFM Watts	1006 / 1144 90 / 128	1009 / 1037 138 / 150	1016 / 925 193 / 167	1024 / 808 244 / 178	290 CFM/ton	CFM Watts	1002 93	1017 197	1024 248	1026 292
	370 CFM/ton	CFM Watts	1266 / 1338 170 / 193	1290 / 1244 238 / 219	1306 / 1146 306 / 239	1311 / 1046 369 / 254	350 CFM/ton	CFM Watts	1199 148	1215 272	1239 333	1236 388
	400 CFM/ton	CFM Watts	1378 / 1591 213 / 310	1404 / 1505 289 / 338	1416 / 1416 360 / 361	1410 / 1324 422 / 377	420 CFM/ton	CFM Watts	1452 246	1480 395	1468 456	1394 476
3.5 tons	450 CFM/ton	CFM Watts	1575 / 1691 307 / 367	1585 / 1607 385 / 396	1572 / 1519 451 / 419	1499 / 1429 477 / 434	450 CFM/ton	CFM Watts	1573 306	1573 451	1505 476	1383 469

**NOTES:**

- \* Models start with "A" or "T"
- † Factory Setting
- Status LED will blink once per 100 CFM requested. In torque mode, actual airflow may be lower.
- Torque mode will reduce airflow when static is above approximately 0.35" water column.
- All heating modes default to Constant CFM.
- Cooling airflow values are with wet coil, no filter

**AM8A0C36 Minimum Heating Airflow Settings**

MINIMUM HEATER AIRFLOW CFM - HEATER MATRIX			
BAYEVA008BK1AA	BAYEVA008BK1AA	BAYEVA008BK1AA	BAYEVA008BK1AA
BAYEVA008LG1AA	BAYEVA008LG1AA	BAYEVA008LG1AA	BAYEVA008LG1AA
BAYEVA008V1SAA	BAYEVA008V1SAA	BAYEVA008V1SAA	BAYEVA008V1SAA
876/979	876/979	876/979	876/979
824/979	824/979	824/979	824/979
927/1236	927/1236	927/1236	927/1236
WITHOUT HEAT PUMP / WITH HP	WITHOUT HEAT PUMP / WITH HP	WITHOUT HEAT PUMP / WITH HP	WITHOUT HEAT PUMP / WITH HP
SEE AIR HANDLER NAMEPLATE			

**NOTE:** Minimum auxiliary heating airflow is automatically configured by the air handler model and the auxiliary heater model number. This is not field adjustable.

**\*AM8A0C42 AIRFLOW PERFORMANCE  
CONSTANT CFM MODE / CONSTANT TORQUE MODE**

OUTDOOR MULTIPLIER (TONS)	COOLING AIRFLOW SETTING	Airflow Power	EXTERNAL STATIC PRESSURE (Constant CFM / Constant Torque)						HEATING AIRFLOW SETTING	Airflow Power	EXTERNAL STATIC PRESSURE					
			0.1	0.3	0.5	0.7	0.9	0.9			0.1	0.3	0.5	0.7	0.9	
2.5 tons	290 CFM/ton	CFM Watts	747 / 905 48 / 77	743 / 764 87 / 94	742 / 591 127 / 102	741 / 342 168 / 106	739 / NA 207 / NA	290 CFM/ton	CFM Watts	744 51	741 90	740 130	738 170	734 209		
	370 CFM/ton	CFM Watts	937 / 1072 80 / 118	942 / 956 129 / 139	946 / 823 179 / 151	947 / 655 227 / 155	944 / 458 273 / 155	350 CFM/ton	CFM Watts	889 76	892 123	894 169	894 215	890 259		
	400 CFM/ton	CFM Watts	1006 / 1136 95 / 138	1014 / 1027 148 / 159	1020 / 903 201 / 173	1022 / 760 253 / 178	1019 / 586 302 / 177	400 CFM/ton	CFM Watts	1006 103	1016 156	1018 209	1019 160	1016 308		
	450 CFM/ton	CFM Watts	1122 / 1247 125 / 176	1135 / 1146 185 / 200	1143 / 1035 245 / 216	1146 / 911 303 / 224	1142 / 768 357 / 223	450 CFM/ton	CFM Watts	1124 136	1135 196	1142 256	1144 313	1140 366		
	290 CFM/ton	CFM Watts	885 / 1026 70 / 106	889 / 904 116 / 125	891 / 763 163 / 136	892 / 590 209 / 139	889 / 341 254 / 143	290 CFM/ton	CFM Watts	884 75	887 121	889 168	889 214	885 257		
3 tons	370 CFM/ton	CFM Watts	1108 / 1233 121 / 171	1120 / 1132 181 / 195	1128 / 1019 240 / 210	1131 / 893 297 / 218	1128 / 747 350 / 217	350 CFM/ton	CFM Watts	1053 115	1062 171	1067 227	1069 280	1066 330		
	400 CFM/ton	CFM Watts	1194 / 1316 147 / 204	1208 / 1220 212 / 229	1218 / 1115 276 / 246	1221 / 999 337 / 255	1215 / 868 393 / 256	400 CFM/ton	CFM Watts	1196 160	1209 225	1218 289	1219 349	1212 403		
	450 CFM/ton	CFM Watts	1343 / 1463 200 / 272	1371 / 1374 275 / 300	1371 / 1279 348 / 320	1368 / 1175 413 / 331	1352 / 1061 469 / 334	450 CFM/ton	CFM Watts	1347 220	1363 295	1371 367	1366 430	1342 480		
	290 CFM/ton	CFM Watts	1020 / 1149 99 / 142	1028 / 1041 152 / 164	1034 / 919 206 / 178	1037 / 779 259 / 183	1034 / 609 308 / 182	290 CFM/ton	CFM Watts	1020 107	1028 160	1033 214	1173 327	1031 315		
	370 † CFM/ton	CFM Watts	1287 / 1408 179 / 245	1304 / 1317 250 / 272	1314 / 1218 320 / 291	1315 / 1110 384 / 301	1304 / 981 441 / 303	350 CFM/ton	CFM Watts	1220 169	1234 236	1243 301	1244 362	1236 417		
3.5 tons †	400 CFM/ton	CFM Watts	1395 / 1514 221 / 299	1413 / 1427 301 / 328	1421 / 1334 374 / 348	1415 / 1233 440 / 361	1369 / 1124 480 / 364	400 † CFM/ton	CFM Watts	1440 244	1416 322	1421 395	1411 458	1355 475		
	450 CFM/ton	CFM Watts	1584 / 1687 313 / 405	1593 / 1605 399 / 435	1576 / 1518 467 / 458	1474 / 1425 477 / 472	1350 / 1326 468 / 477	450 CFM/ton	CFM Watts	1589 347	1592 428	1545 474	1434 473	1315 463		
	290 CFM/ton	CFM Watts	1156 / 1302 135 / 197	1169 / 1205 197 / 222	1178 / 1098 259 / 239	1181 / 981 319 / 248	1174 / 848 383 / 249	290 CFM/ton	CFM Watts	1157 147	1169 209	1177 271	1179 330	1174 383		
	370 CFM/ton	CFM Watts	1487 / 1618 288 / 359	1500 / 1534 369 / 389	1496 / 1445 441 / 411	1445 / 1350 481 / 425	1319 / 1248 470 / 429	350 CFM/ton	CFM Watts	1400 244	1416 322	1421 395	1411 458	1335 475		
	400 CFM/ton	CFM Watts	1616 / 1728 363 / 433	1614 / 1646 443 / 464	1543 / 1543 475 / 475	1423 / 1423 472 / 472	1301 / 1301 463 / 463	400 CFM/ton	CFM Watts	1615 363	1615 444	1545 474	1431 471	1313 462		
4 tons	450 CFM/ton	CFM Watts	1711 / 1711 432 / 432	1621 / 1621 456 / 456	1514 / 1514 465 / 465	1393 / 1393 460 / 460	1273 / 1273 453 / 453	450 CFM/ton	CFM Watts	1716 430	1629 453	1528 462	1411 458	1297 452		

**NOTES:**

- \* Models start with "A" or "T"
- † Factory Setting
- Status LED will blink once per 100 CFM requested. In torque mode, actual airflow may be lower.
- Torque mode will reduce airflow when static is above approximately 0.35" water column.
- All heating modes default to Constant CFM.
- Cooling airflow values are with wet coil, no filter

**AM8A0C42 Minimum Heating Airflow Settings**

MODEL NO.	MINIMUM HEATER AIRFLOW CFM - HEATER MATRIX					
	BAYEAC05BK1AA 978/1093	BAYEAC08BK1AA 978/1380	BAYEAC10BK1AA 1035/1380	BAYEAC10LG3AA 920/1093	BAYEVC16BK1AA 1035/1438	BAYEVC15LG3AA 1150/1495
*AM8A0C42V31SAA	BAYEAC08BK1AA 978/1380	BAYEAC10BK1AA 1035/1380	BAYEAC10LG3AA 920/1093	BAYEVC16BK1AA 1035/1438	BAYEVC15LG3AA 1150/1495	BAYEVC20BK1AA 1380/1610
WITHOUT HEAT PUMP / WITH HP SEE AIR HANDLER NAMEPLATE						

**NOTE:** Minimum auxiliary heating airflow is automatically configured by the air handler model and the auxiliary heater model number. This is not field adjustable.

*AM8A0C48 AIRFLOW PERFORMANCE CONSTANT CFM MODE / CONSTANT TORQUE MODE													
OUTDOOR MULTIPLIER (TONS)	COOLING AIRFLOW SETTING	Airflow Power	EXTERNAL STATIC PRESSURE (Constant CFM / Constant Torque)				HEATING AIRFLOW SETTING	Airflow Power	EXTERNAL STATIC PRESSURE				
			0.1	0.3	0.5	0.7			0.9	0.1	0.3	0.5	0.7
3 tons	290 CFM/ton	CFM Watts	894 / 1018 69 / 91	900 / 897 114 / 114	896 / 767 157 / 130	886 / 622 195 / 137	290 CFM/ton	CFM Watts	893 72	900 118	893 159	883 197	864 230
	350 CFM/ton	CFM Watts	1067 / 1180 106 / 132	1073 / 1078 158 / 160	1072 / 972 208 / 180	1065 / 859 252 / 192	350 CFM/ton	CFM Watts	1068 112	1073 164	1070 213	1062 257	1049 295
	400 CFM/ton	CFM Watts	1205 / 1314 145 / 176	1212 / 1222 203 / 206	1213 / 1128 259 / 229	1208 / 1029 309 / 244	400 CFM/ton	CFM Watts	1207 154	1212 212	1212 266	1206 315	1196 359
	450 CFM/ton	CFM Watts	1343 / 1451 193 / 232	1352 / 1367 259 / 264	1355 / 1280 320 / 289	1346 / 1190 377 / 305	450 CFM/ton	CFM Watts	1344 206	1352 270	1354 331	1352 387	1344 436
	290 CFM/ton	CFM Watts	1034 / 1149 98 / 123	1041 / 1044 149 / 150	1038 / 934 197 / 170	1031 / 817 240 / 181	290 CFM/ton	CFM Watts	1034 103	1040 154	1037 202	1028 244	1014 281
3.5 tons	350 CFM/ton	CFM Watts	1228 / 1336 152 / 185	1235 / 1246 212 / 215	1236 / 1153 268 / 238	1232 / 1056 319 / 293	350 CFM/ton	CFM Watts	1229 162	1235 221	1236 276	1230 326	1220 371
	400 CFM/ton	CFM Watts	1389 / 1498 212 / 253	1399 / 1415 280 / 286	1403 / 1331 343 / 311	1401 / 1244 402 / 328	400 CFM/ton	CFM Watts	1392 226	1400 293	1403 356	1400 413	1394 465
	450 CFM/ton	CFM Watts	1558 / 1669 290 / 343	1570 / 1592 367 / 377	1575 / 1514 439 / 404	1568 / 1351 505 / 422	450 CFM/ton	CFM Watts	1561 310	1572 386	1576 457	1574 521	1567 577
	290 CFM/ton	CFM Watts	1168 / 1298 133 / 170	1175 / 1205 191 / 200	1175 / 1109 244 / 223	1170 / 1010 293 / 237	290 CFM/ton	CFM Watts	1168 141	1176 198	1174 251	1168 299	1157 341
	350 † CFM/ton	CFM Watts	1389 / 1517 212 / 262	1399 / 1436 280 / 295	1403 / 1352 343 / 321	1401 / 1266 402 / 338	350 CFM/ton	CFM Watts	1392 226	1400 293	1403 356	1400 413	1394 465
4 tons †	400 CFM/ton	CFM Watts	1583 / 1714 303 / 370	1595 / 1639 382 / 546	1601 / 1562 455 / 431	1600 / 1483 521 / 450	400 † CFM/ton	CFM Watts	1586 325	1597 402	1601 474	1599 538	1591 595
	450 CFM/ton	CFM Watts	1790 / 1918 429 / 511	1800 / 1848 515 / 546	1808 / 1775 594 / 573	1793 / 1701 663 / 592	450 CFM/ton	CFM Watts	1794 459	1801 544	1800 620	1766 665	1667 655
	290 CFM/ton	CFM Watts	1301 / 1429 177 / 222	1310 / 1344 241 / 253	1312 / 1256 300 / 278	1309 / 1165 404 / 302	290 CFM/ton	CFM Watts	1302 189	1310 252	1311 310	1309 355	1301 403
	350 CFM/ton	CFM Watts	1558 / 1688 290 / 354	1570 / 1613 367 / 389	1575 / 1535 439 / 415	1568 / 1373 505 / 434	350 CFM/ton	CFM Watts	1557 290	1570 367	1575 439	1575 505	1569 563
	400 CFM/ton	CFM Watts	1790 / 1918 429 / 511	1800 / 1848 515 / 546	1801 / 1775 594 / 573	1793 / 1701 663 / 592	400 CFM/ton	CFM Watts	1789 428	1799 515	1801 594	1794 663	1701 659
4.5 tons**	450 CFM/ton	CFM Watts	2018 / 2018 605 / 605	1973 / 1973 656 / 656	1857 / 1857 645 / 645	1749 / 1749 637 / 637	450 CFM/ton	CFM Watts	2018 605	1975 656	1863 643	1757 634	1660 628

- \* Models start with "A" or "T"
- † Factory Setting
- \*\* Not an actual OD size
- Status LED will blink once per 100 CFM requested. In torque mode, actual airflow may be lower.
- Torque mode will reduce airflow when static is above approximately 0.4" water column.
- If the air handler is applied in downflow or horizontal configurations, the airflow should not exceed 2000 CFM. Airflow above 2000 CFM could result in water blow-off.
- All heating modes default to Constant CFM.
- Cooling airflow values are with wet coil, no filter

### AM8A0C48 Minimum Heating Airflow Settings

MODEL NO. *AM8A0C48V4ISA	MINIMUM HEATER AIRFLOW CFM - HEATER MATRIX					
	BAYEVA0CBK1AA 1063/1186	BAYEVA0CBK1AA 1063/1500	BAYEVA0CBK1AA 1063/1500	BAYEVA0CBK1AA 1125/1585	BAYEVA0CBK1AA 1125/1585	BAYEVA0CBK1AA 1500/1750
	BAYEVA0CBK1AA 1063/1186	BAYEVA0CBK1AA 1063/1500	BAYEVA0CBK1AA 1063/1500	BAYEVA0CBK1AA 1125/1585	BAYEVA0CBK1AA 1125/1585	BAYEVA0CBK1AA 1500/1750
	BAYEVA0CBK1AA 1063/1186	BAYEVA0CBK1AA 1063/1500	BAYEVA0CBK1AA 1063/1500	BAYEVA0CBK1AA 1125/1585	BAYEVA0CBK1AA 1125/1585	BAYEVA0CBK1AA 1500/1750

NOTE: Minimum auxiliary heating airflow is automatically configured by the air handler model and the auxiliary heater model number. This is not field adjustable.

*AM8A0C60 AIRFLOW PERFORMANCE CONSTANT CFM MODE / CONSTANT TORQUE MODE														
OUTDOOR MULTIPLIER (TONS)	COOLING AIRFLOW SETTING	Airflow Power	EXTERNAL STATIC PRESSURE (Constant CFM / Constant Torque)			HEATING AIRFLOW SETTING	Airflow Power	EXTERNAL STATIC PRESSURE						
			0.1	0.3	0.5			0.7	0.9	0.1	0.3	0.5	0.7	0.9
3.5 tons	290 CFM/ton	CFM Watts	1040 / 1151 94 / 119	1068 / 1056 151 / 148	1075 / 941 203 / 168	1066 / 799 247 / 175	1046 / 607 283 / 165	290 CFM/ton	CFM Watts	1039 95	1065 151	1071 203	1063 247	1045 283
	370 CFM/ton	CFM Watts	1312 / 1343 171 / 178	1332 / 1264 236 / 210	1336 / 1174 296 / 235	1329 / 1068 349 / 250	1314 / 945 392 / 251	350 CFM/ton	CFM Watts	1247 150	1266 213	1270 270	1263 321	1248 363
	400 CFM/ton	CFM Watts	1408 / 1496 206 / 238	1425 / 1426 274 / 273	1429 / 1346 337 / 301	1423 / 1256 393 / 319	1410 / 1154 440 / 325	400 CFM/ton	CFM Watts	1407 206	1423 274	1426 337	1421 392	1409 439
	450 CFM/ton	CFM Watts	1565 / 1650 274 / 312	1579 / 1585 348 / 348	1584 / 1512 416 / 378	1580 / 1432 477 / 398	1569 / 1343 529 / 407	450 CFM/ton	CFM Watts	1564 274	1578 348	1582 416	1578 476	1569 529
	290 CFM/ton	CFM Watts	1186 / 1304 131 / 164	1208 / 1223 192 / 196	1213 / 1128 248 / 220	1206 / 1018 297 / 234	1189 / 887 337 / 233	290 CFM/ton	CFM Watts	1185 131	1206 192	1210 248	1203 297	1187 337
	370 CFM/ton	CFM Watts	1480 / 1514 235 / 245	1495 / 1444 306 / 280	1499 / 1365 372 / 308	1495 / 1277 430 / 327	1482 / 1177 479 / 334	350 CFM/ton	CFM Watts	1407 206	1423 274	1426 337	1421 392	1409 439
4 tons	400 CFM/ton	CFM Watts	1587 / 1689 285 / 332	1602 / 1625 360 / 369	1606 / 1554 429 / 399	1602 / 1475 490 / 420	1592 / 1399 543 / 430	400 CFM/ton	CFM Watts	1587 285	1600 360	1604 428	1601 490	1592 543
	450 CFM/ton	CFM Watts	1770 / 1873 386 / 443	1784 / 1813 468 / 481	1789 / 1747 543 / 512	1788 / 1675 612 / 534	1782 / 1597 671 / 546	450 CFM/ton	CFM Watts	1770 385	1783 467	1788 543	1788 611	1782 671
	290 CFM/ton	CFM Watts	1322 / 1431 174 / 211	1340 / 1358 240 / 245	1345 / 1274 300 / 271	1338 / 1179 353 / 288	1323 / 1069 397 / 292	290 CFM/ton	CFM Watts	1321 174	1338 240	1342 300	1336 352	1322 396
	370 † CFM/ton	CFM Watts	1646 / 1667 315 / 320	1660 / 1602 392 / 357	1665 / 1530 463 / 386	1662 / 1451 527 / 407	1653 / 1363 582 / 417	350 CFM/ton	CFM Watts	1564 274	1578 348	1582 416	1578 476	1569 529
	400 CFM/ton	CFM Watts	1770 / 1873 386 / 443	1784 / 1813 468 / 481	1789 / 1747 543 / 512	1788 / 1675 612 / 534	1781 / 1597 671 / 546	400 † CFM/ton	CFM Watts	1770 385	1783 467	1788 543	1788 611	1782 671
	450 CFM/ton	CFM Watts	1989 / 2099 535 / 612	2004 / 2042 627 / 650	2012 / 1980 712 / 681	2013 / 1913 788 / 703	2009 / 1842 855 / 716	450 CFM/ton	CFM Watts	1989 534	2003 626	2011 711	2014 788	2011 856
5 tons	290 CFM/ton	CFM Watts	1452 / 1557 224 / 265	1469 / 1489 294 / 301	1473 / 1413 358 / 329	1468 / 1327 415 / 348	1455 / 1231 463 / 356	290 CFM/ton	CFM Watts	1452 224	1467 294	1471 358	1466 415	1454 463
	370 CFM/ton	CFM Watts	1817 / 1826 415 / 451	1831 / 1765 499 / 451	1837 / 1698 576 / 481	1837 / 1624 647 / 503	1831 / 1544 708 / 515	350 CFM/ton	CFM Watts	1723 357	1736 437	1741 511	1740 578	1734 636
	400 CFM/ton	CFM Watts	1964 / 2073 516 / 590	1978 / 2015 607 / 629	1986 / 1953 690 / 660	1987 / 1886 766 / 682	1983 / 1814 832 / 695	400 CFM/ton	CFM Watts	1964 515	1978 606	1985 690	1988 766	1985 833
	450 CFM/ton	CFM Watts	2231 / 2347 741 / 842	2245 / 2292 842 / 879	2252 / 2233 934 / 908	2252 / 2171 1015 / 930	2185 / 2104 1024 / 941	450 CFM/ton	CFM Watts	2232 741	2245 842	2252 934	2252 1016	2186 1023

- \* Models start with "A" or "T"
- † Factory Setting
- \*\* Not an actual OD size
- Status LED will blink once per 100 CFM requested. In torque mode, actual airflow may be lower.
- Torque mode will reduce airflow when static is above approximately 0.4" water column.
- If the air handler is applied in downflow or horizontal configurations, the airflow should not exceed 2000 CFM. Airflow above 2000 CFM could result in water blow-off.
- All heating modes default to Constant CFM.
- Cooling airflow values are with wet coil, no filter

### AM8A0C60 Minimum Heating Airflow Settings

MODEL NO. AM8A0C60V51SAA	MINIMUM HEATER AIRFLOW CFM - HEATER MATRIX							
	BAYEVC08BK1AA 1062/1188	BAYEVC08BK1AA 1062/1500	BAYEVC08BK1AA 1062/1500	BAYEVC08BK1AA 1062/1500	BAYEVC08BK1AA 1062/1500	BAYEVC08BK1AA 1062/1500	BAYEVC08BK1AA 1062/1500	BAYEVC08BK1AA 1062/1500
	BAYEVC10BK1AA 1125/1500	BAYEVC10BK1AA 1125/1500	BAYEVC10BK1AA 1125/1500	BAYEVC10BK1AA 1125/1500	BAYEVC10BK1AA 1125/1500	BAYEVC10BK1AA 1125/1500	BAYEVC10BK1AA 1125/1500	BAYEVC10BK1AA 1125/1500
	BAYEVC10BK1AA 1062/1500	BAYEVC10BK1AA 1062/1500	BAYEVC10BK1AA 1062/1500	BAYEVC10BK1AA 1062/1500	BAYEVC10BK1AA 1062/1500	BAYEVC10BK1AA 1062/1500	BAYEVC10BK1AA 1062/1500	BAYEVC10BK1AA 1062/1500
	BAYEVC10BK1AA 1062/1500	BAYEVC10BK1AA 1062/1500	BAYEVC10BK1AA 1062/1500	BAYEVC10BK1AA 1062/1500	BAYEVC10BK1AA 1062/1500	BAYEVC10BK1AA 1062/1500	BAYEVC10BK1AA 1062/1500	BAYEVC10BK1AA 1062/1500
	BAYEVC10BK1AA 1062/1500	BAYEVC10BK1AA 1062/1500	BAYEVC10BK1AA 1062/1500	BAYEVC10BK1AA 1062/1500	BAYEVC10BK1AA 1062/1500	BAYEVC10BK1AA 1062/1500	BAYEVC10BK1AA 1062/1500	BAYEVC10BK1AA 1062/1500

NOTE: Minimum auxiliary heating airflow is automatically configured by the air handler model and the auxiliary heater model number. This is not field adjustable.



# Electrical Data

## TAM8 HEATER ATTRIBUTE DATA

Heater Attribute Data											
*AM8A0A24V21SA											
Heater Model No.	No. of Circuits	240 Volt					208 Volt				
		Capacity		Heater Amps per Circuit	Minimum Circuit Ampacity	Maximum Overload Protection	Capacity		Heater Amps per Circuit	Minimum Circuit Ampacity	Maximum Overload Protection
		kW	BTUH				kW	BTUH			
No Heater	0	-	-	3.0**	4	15	-	-	3.0**	4	15
BAYEVAC05++1	1	4.80	16400	20.0	29	30	3.60	12300	17.3	25	25
BAYEVAC08++1	1	7.68	26200	32.0	44	45	5.76	19700	27.7	38	40
BAYEVAC10++1	1	9.60	32800	40.0	54	60	7.20	24600	34.6	47	50
BAYEVAC10LG3	1-3 PH	9.60	32800	23.1	32	35	7.20	24600	20.0	28	30

Note: \* May be "A" or "T"  
Note: \*\* Motor Amps

Heater Attribute Data											
*AM8A0B30V21SA											
Heater Model No.	No. of Circuits	240 Volt					208 Volt				
		Capacity		Heater Amps per Circuit	Minimum Circuit Ampacity	Maximum Overload Protection	Capacity		Heater Amps per Circuit	Minimum Circuit Ampacity	Maximum Overload Protection
		kW	BTUH				kW	BTUH			
No Heater	0	-	-	3.0**	4	15	-	-	3.0**	4	15
BAYEVAC05++1	1	4.80	16400	20.0	29	30	3.60	12300	17.3	25	25
BAYEVAC08++1	1	7.68	26200	32.0	44	45	5.76	19700	27.7	38	40
BAYEVAC10++1	1	9.60	32800	40.0	54	60	7.20	24600	34.6	47	50
BAYEVAC10LG3	1-3 PH	9.60	32800	23.1	32	35	7.20	24600	20.0	28	30
BAYEVBC15LG3	1-3 PH	14.40	42000	34.6	47	50	10.80	36900	30.0	41	45
BAYEVBC15BK1 - Circuit 1 ①	2	9.60	32800	40.0	54	60	7.20	24600	34.6	47	50
BAYEVBC15BK1 - Circuit 2		4.80	16400	20.0	25	25	3.60	12300	17.3	22	25

Note: \* May be "A" or "T"  
Note: \*\* Motor Amps  
① MCA and MOP for circuit 1 contains the motor amps

Notes:

1. See Product Data or Air Handler nameplate for approved combinations of Air Handlers and Heaters
2. Heater model numbers may have additional suffix digits.



**TRANE®**

# Electrical Data

## TAM8 HEATER ATTRIBUTE DATA

Heater Attribute Data											
*AM8A0C36V31SA											
Heater Model No.	No. of Circuits	240 Volt					208 Volt				
		Capacity		Heater Amps per Circuit	Minimum Circuit Ampacity	Maximum Overload Protection	Capacity		Heater Amps per Circuit	Minimum Circuit Ampacity	Maximum Overload Protection
		kW	BTUH				kW	BTUH			
No Heater	0	-	-	3.0**	4	15	-	-	3.0**	4	15
BAYEVAC05++1	1	4.80	16400	20.0	29	30	3.60	12300	17.3	25	25
BAYEVAC08++1	1	7.68	26200	32.0	44	45	5.76	19700	27.7	38	40
BAYEVAC10++1	1	9.60	32800	40.0	54	60	7.20	24600	34.6	47	50
BAYEVAC10LG3	1-3 PH	9.60	32800	23.1	32	35	7.20	24600	20.0	28	30
BAYEVBC15LG3	1-3 PH	14.40	42000	34.6	47	50	10.80	36900	30.0	41	45
BAYEVBC15BK1 - Circuit 1 ① BAYEVBC15BK1 - Circuit 2	2	9.60	32800	40.0	54	60	7.20	24600	34.6	47	50
		4.80	16400	20.0	25	25	3.60	12300	17.3	22	25
BAYEVBC20BK1 - Circuit 1 ① BAYEVBC20BK1 - Circuit 2	2	9.60	32800	40.0	54	60	7.20	24600	34.6	47	50
		9.60	32800	40.0	50	50	7.20	24600	34.6	43	45

Note: \* May be "A" or "T"  
 Note: \*\* Motor Amps  
 ① MCA and MOP for circuit 1 contains the motor amps

Heater Attribute Data											
*AM8A0C42V31SA											
Heater Model No.	No. of Circuits	240 Volt					208 Volt				
		Capacity		Heater Amps per Circuit	Minimum Circuit Ampacity	Maximum Overload Protection	Capacity		Heater Amps per Circuit	Minimum Circuit Ampacity	Maximum Overload Protection
		kW	BTUH				kW	BTUH			
No Heater	0	-	-	3.0**	4	15	-	-	3.0**	4	15
BAYEVAC05++1	1	4.80	16400	20.0	29	30	3.60	12300	17.3	25	25
BAYEVAC08++1	1	7.68	26200	32.0	44	45	5.76	19700	27.7	38	40
BAYEVAC10++1	1	9.60	32800	40.0	54	60	7.20	24600	34.6	47	50
BAYEVAC10LG3	1-3 PH	9.60	32800	23.1	32	35	7.20	24600	20.0	28	30
BAYEVBC15LG3	1-3 PH	14.40	42000	34.6	47	50	10.80	36900	30.0	41	45
BAYEVBC15BK1 - Circuit 1 ① BAYEVBC15BK1 - Circuit 2	2	9.60	32800	40.0	54	60	7.20	24600	34.6	47	50
		4.80	16400	20.0	25	25	3.60	12300	17.3	22	25
BAYEVBC20BK1 - Circuit 1 ① BAYEVBC20BK1 - Circuit 2	2	9.60	32800	40.0	54	60	7.20	24600	34.6	47	50
		9.60	32800	40.0	50	50	7.20	24600	34.6	43	45

Note: \* May be "A" or "T"  
 Note: \*\* Motor Amps  
 ① MCA and MOP for circuit 1 contains the motor amps

Notes:

1. See Product Data or Air Handler nameplate for approved combinations of Air Handlers and Heaters
2. Heater model numbers may have additional suffix digits.



# Electrical Data

## TAM8 HEATER ATTRIBUTE DATA

Heater Attribute Data											
*AM8A0C48V41SA											
Heater Model No.	No. of Circuits	240 Volt					208 Volt				
		Capacity		Heater Amps per Circuit	Minimum Circuit Ampacity	Maximum Overload Protection	Capacity		Heater Amps per Circuit	Minimum Circuit Ampacity	Maximum Overload Protection
		kW	BTUH				kW	BTUH			
No Heater	0	-	-	4.2**	5	15	-	-	4.2**	5	15
BAYEVAC05++1	1	4.80	16400	20.0	30	30	3.60	12300	17.3	27	30
BAYEVAC08++1	1	7.68	26200	32.0	45	45	5.76	19700	27.7	40	40
BAYEVAC10++1	1	9.60	32800	40.0	55	60	7.20	24600	34.6	49	50
BAYEVAC10LG3	1-3 PH	9.60	32800	23.1	34	35	7.20	24600	20.0	30	30
BAYEVBC15LG3	1-3 PH	14.40	42000	34.6	48	50	10.80	36900	30.0	42	45
BAYEVBC15BK1 - Circuit 1 ① BAYEVBC15BK1 - Circuit 2	2	9.60	32800	40.0	55	60	7.20	24600	34.6	49	50
		4.80	16400	20.0	25	25	3.60	12300	17.3	22	25
BAYEVBC20BK1 - Circuit 1 ① BAYEVBC20BK1 - Circuit 2	2	9.60	32800	40.0	55	60	7.20	24600	34.6	49	50
		9.60	32800	40.0	50	50	7.20	24600	34.6	43	45
BAYEVCC25BK1 - Circuit 1 ① BAYEVCC25BK1 - Circuit 2 BAYEVCC25BK1 - Circuit 3	3	9.60	32800	40.0	55	60	7.20	24600	34.6	49	50
		9.60	32800	40.0	50	50	7.20	24600	34.6	43	45
		4.80	16400	20.0	25	25	3.60	12300	17.3	22	25

Note: \* May be "A" or "T"  
 Note: \*\* Motor Amps  
 ① MCA and MOP for circuit 1 contains the motor amps

Heater Attribute Data											
*AM8A0C60V51SA											
Heater Model No.	No. of Circuits	240 Volt					208 Volt				
		Capacity		Heater Amps per Circuit	Minimum Circuit Ampacity	Maximum Overload Protection	Capacity		Heater Amps per Circuit	Minimum Circuit Ampacity	Maximum Overload Protection
		kW	BTUH				kW	BTUH			
No Heater	0	-	-	5.5**	7	15	-	-	5.5**	7	15
BAYEVAC05++1	1	4.80	16400	20.0	30	30	3.60	12300	17.3	27	30
BAYEVAC08++1	1	7.68	26200	32.0	45	45	5.76	19700	27.7	40	40
BAYEVAC10++1	1	9.60	32800	40.0	55	60	7.20	24600	34.6	49	50
BAYEVAC10LG3	1-3 PH	9.60	32800	23.1	34	35	7.20	24600	20.0	30	30
BAYEVBC15LG3	1-3 PH	14.40	42000	34.6	48	50	10.80	36900	30.0	42	45
BAYEVBC15BK1 - Circuit 1 ① BAYEVBC15BK1 - Circuit 2	2	9.60	32800	40.0	55	60	7.20	24600	34.6	49	50
		4.80	16400	20.0	25	25	3.60	12300	17.3	22	25
BAYEVBC20BK1 - Circuit 1 ① BAYEVBC20BK1 - Circuit 2	2	9.60	32800	40.0	55	60	7.20	24600	34.6	49	50
		9.60	32800	40.0	50	50	7.20	24600	34.6	43	45
BAYEVCC25BK1 - Circuit 1 ① BAYEVCC25BK1 - Circuit 2 BAYEVCC25BK1 - Circuit 3	3	9.60	32800	40.0	55	60	7.20	24600	34.6	49	50
		9.60	32800	40.0	50	50	7.20	24600	34.6	43	45
		4.80	16400	20.0	25	25	3.60	12300	17.3	22	25

Note: \* May be "A" or "T"  
 Note: \*\* Motor Amps  
 ① MCA and MOP for circuit 1 contains the motor amps

Notes:

1. See Product Data or Air Handler nameplate for approved combinations of Air Handlers and Heaters
2. Heater model numbers may have additional suffix digits.



# Electrical Data

---

## AIR HANDLER ELECTRIC HEATER PRESSURE DROP

Air handler electric heater pressure drop is negligible for the heaters and is included in the airflow data for the Series 8 air handlers.





# Electrical Data

## TAM8 AIR HANDLER AND HEATER MATRIX - ALLOWBLE COMBINATIONS

APPROVED AIR HANDLER - HEATER COMBINATIONS									
AIR HANDLER	HEATER MODEL NUMBER BAYEV-								
MODEL NUMBER	AC05BK1AA 4.80 Kw BK	AC05LG1AA 4.80 Kw LG	AC08BK1AA 7.68 Kw BK	AC08LG1AA 7.68 Kw LG	AC10BK1AA 9.60 Kw BK	AC10LG1AA 9.60 Kw LG	BC15BK1AA 14.40 Kw BK	BC20BK1AA 19.20 Kw BK	CC25BK1AA 24.00 Kw BK
*AM8A0A24H21SA	Y	Y	Y	Y	Y	Y	-	-	-
*AM8A0B30H21SA	Y	Y	Y	Y	Y	Y	Y	-	-
*AM8A0C36H31SA	Y	Y	Y	Y	Y	Y	Y	Y	-
*AM8A0C42H31SA	Y	Y	Y	Y	Y	Y	Y	Y	-
*AM8A0C48H41SA	Y	Y	Y	Y	Y	Y	Y	Y	Y
*AM8A0C60H51SA	Y	Y	Y	Y	Y	Y	Y	Y	Y

\* May be "A" or "T"

APPROVED AIR HANDLER - HEATER COMBINATIONS		
AIR HANDLER	HEATER MODEL NUMBER BAYEV-	
MODEL NUMBER	AC10LG3AA 9.60 Kw LG	BC15LG3AA 14.4 Kw LG
*AM8A0A24H21SA	Y	-
*AM8A0B30H21SA	Y	Y
*AM8A0C36H31SA	Y	Y
*AM8A0C42H31SA	Y	Y
*AM8A0C48H41SA	Y	Y
*AM8A0C60H51SA	Y	Y

\* May be "A" or "T"

# WIRING DIAGRAM FOR TAM8 AIR HANDLERS

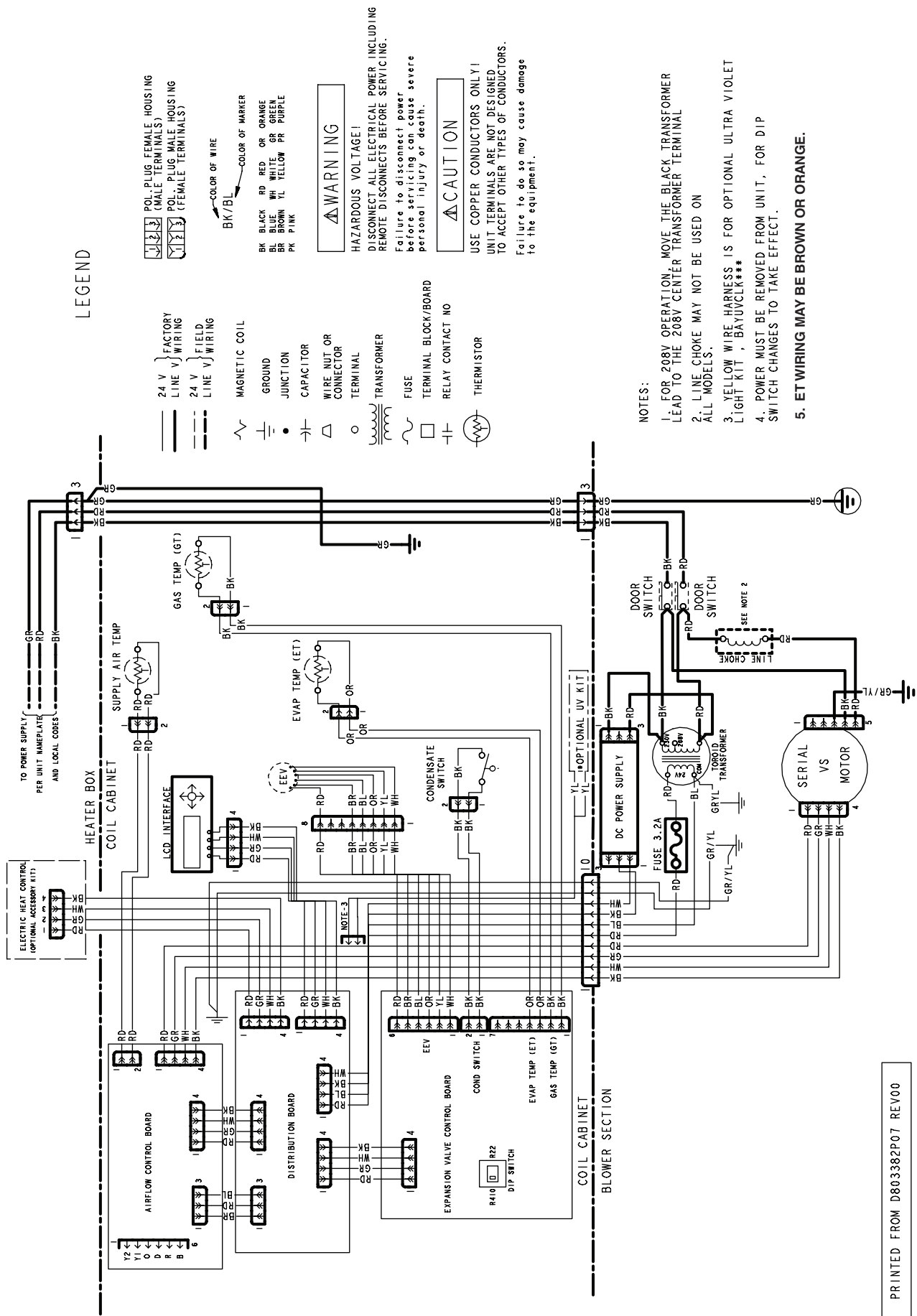

PRINTED FROM D803382P07 REV00

# Field Wiring

## TAM8 Fully Communicating System



Comfort Control

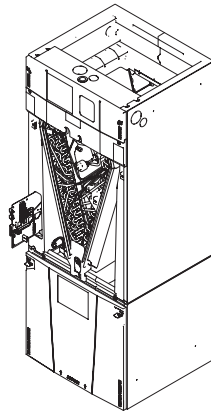

Air Handler

## Communicating Outdoor Unit

Neatly bundle all low voltage wires behind the service valve cover as shown.

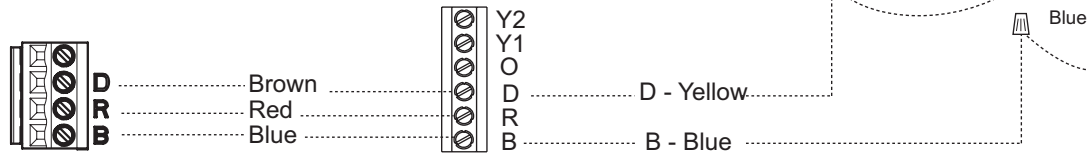
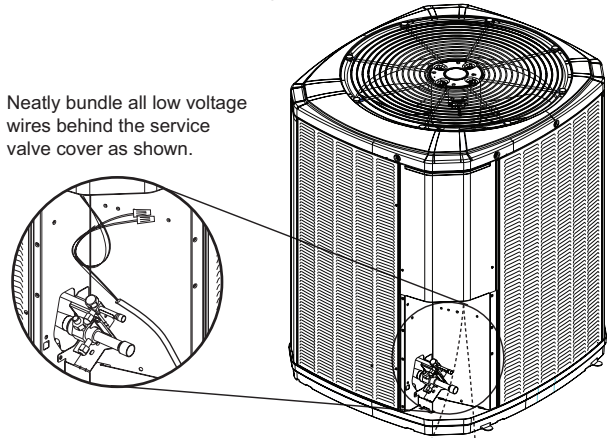

..... Field wiring

**Notes:**

- If a 3rd party condensate overflow switch is installed, it should be wired in series with R to the thermostat or connected to the External Switch terminals on the AFC. See External Switch wiring section.
- For 24 VAC Outdoor equipment, accessory BAYCC24VK01A must be ordered separately
- "D" is the Data line. Installer to select a wire color.



**TRANE®**

# TAM8 Convertibility

\* Note: No internal modifications required for any position.

① Badge rotation will keep brand in correct position

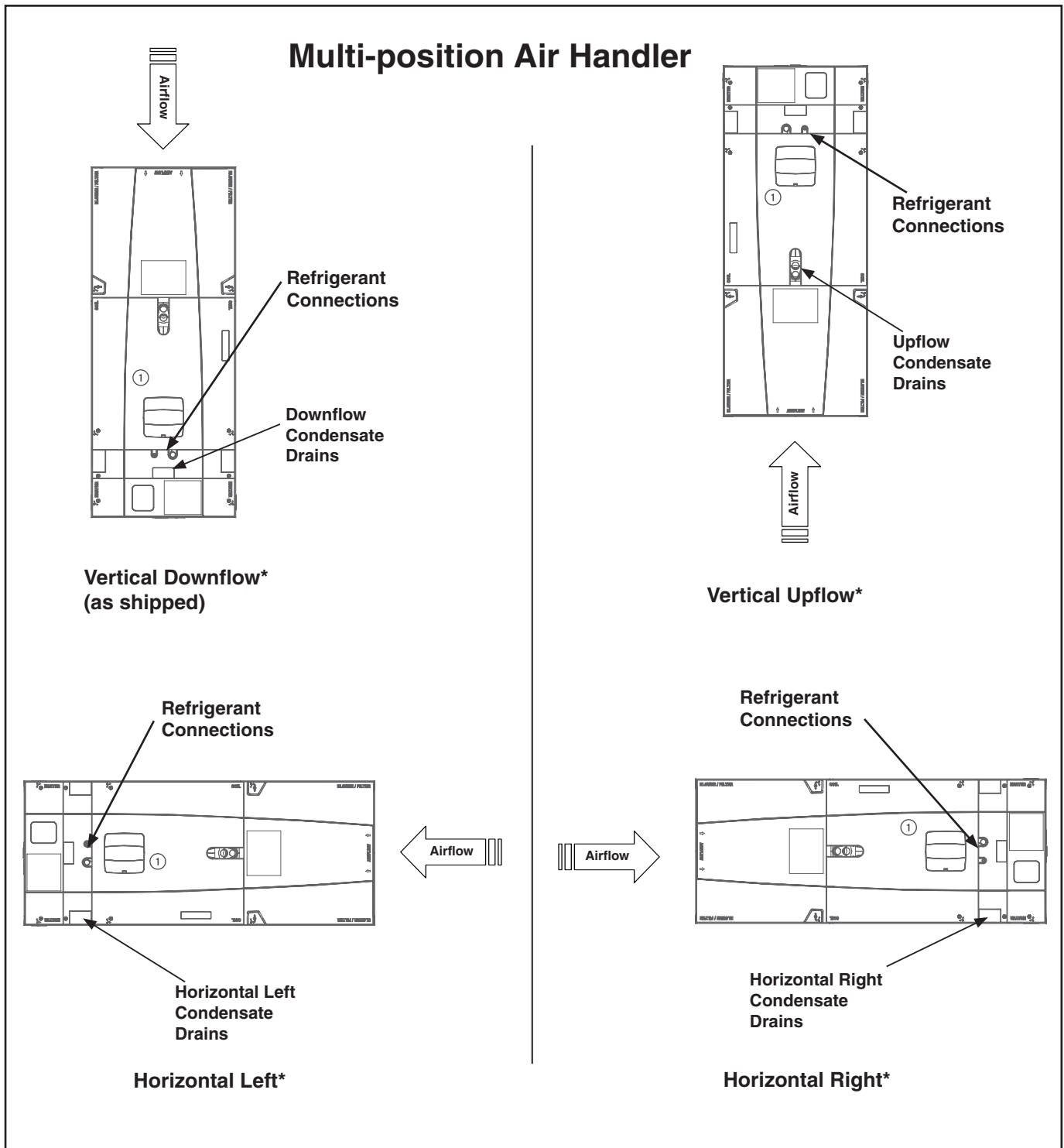

## Dimensions

### TAM8 AIR HANDLER DIMENSIONAL DATA

Model No.	H	W
TAM8A0A24	49.9	17.5
TAM8A0B30	55.7	21.3
TAM8A0C36	56.9	23.5
TAM8A0C42	56.9	23.5
TAM8A0C48	61.7	23.5
TAM8A0C60	61.7	23.5

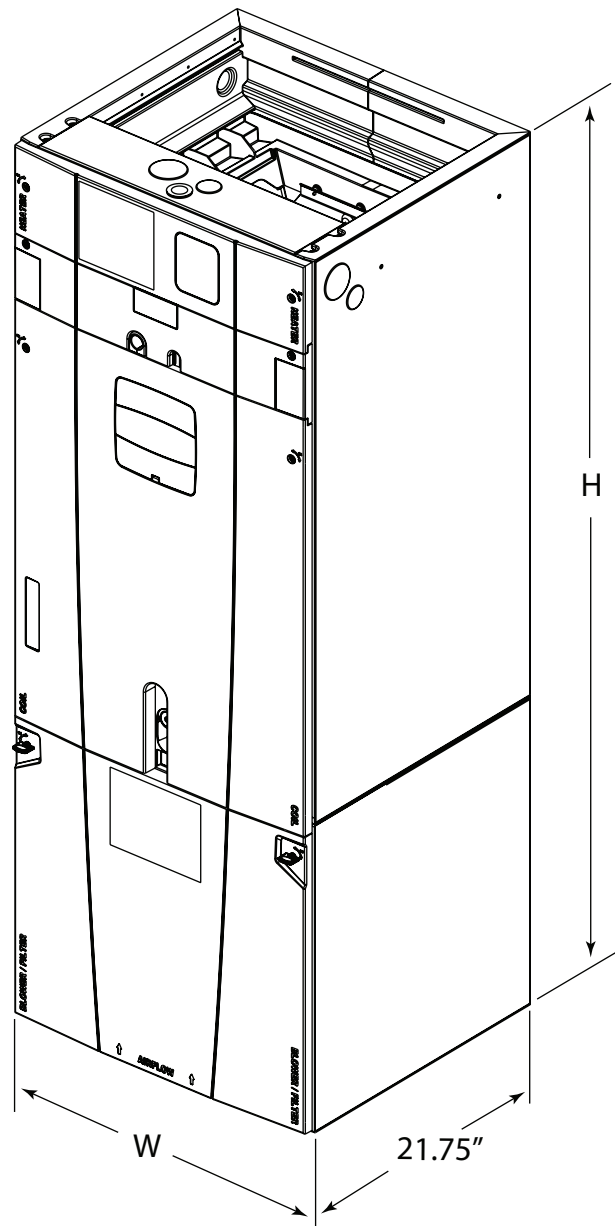

TAM8 AIR HANDLERS ARE ALL TWO  
PIECE CABINETS.

# TAM8 OUTLINE DRAWING

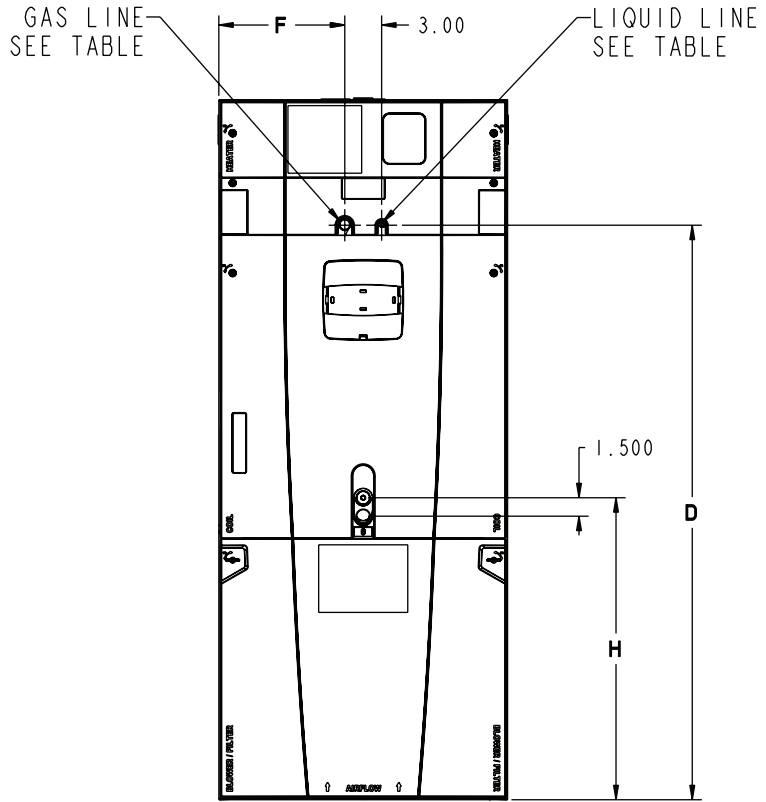
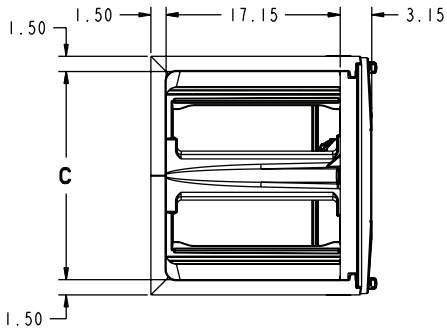
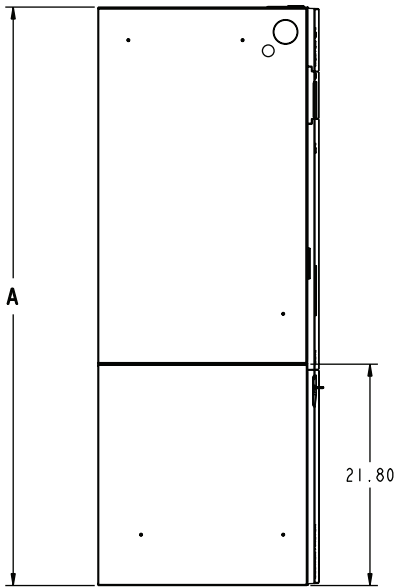
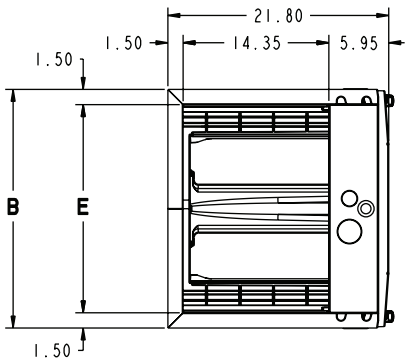

MINIMUM UNIT CLEARANCE TABLE		
	TO COMBUSTIBLE MATERIAL (REQUIRED)	SERVICE CLEARANCE (RECOMMENDED)
SIDES	0"	2"
FRONT	0"	21"
BACK	0"	0"
INLET DUCT	0"	
OUTLET DUCT	0"	

MODEL NO.	A	B	C	D	E	F	H	FLOW CONTROL	GAS LINE BRAZE	LIQ LINE BRAZE
*AM8A0A24V21CA	49.9	17.5	14.5	39.6	14.5	7.3	24.4	EEV	3/4	3/8
*AM8A0B30V21CA	55.7	21.3	18.4	45.5	18.4	9.2	24.8	EEV	3/4	3/8
*AM8A0C36V31CA	56.9	23.5	20.5	46.7	20.5	10.3	24.2	EEV	7/8	3/8
*AM8A0C42V31CA	56.9	23.5	20.5	46.7	20.5	10.3	24.5	EEV	7/8	3/8
*AM8A0C48V41CA	61.7	23.5	20.5	51.5	20.5	10.3	24.9	EEV	7/8	3/8
*AM8A0C60V51CA	61.7	23.5	20.5	51.5	20.5	10.3	24.9	EEV	7/8	3/8

\* May be "A" or "T"





---

07/11

---

---

**Trane**  
**6200 Troup Highway**  
**Tyler, TX 75707**  
**[www.trane.com](http://www.trane.com)**

*The manufacturer has a policy of continuous product and product data improvement and it reserves the right to change design and specifications without notice.*