



TRANE®

Multi-position, Upflow, Horizontal Left, or Horizontal Right, Modular Air Handlers

60 HZ Convertible Air Handlers

Model: Series 2 Air Handlers 1.5 - 3 ton

GAF2A0A18S11SE

GAF2A0A24S21SE

GAF2A0A30S21SE

GAF2A0A36S31SE

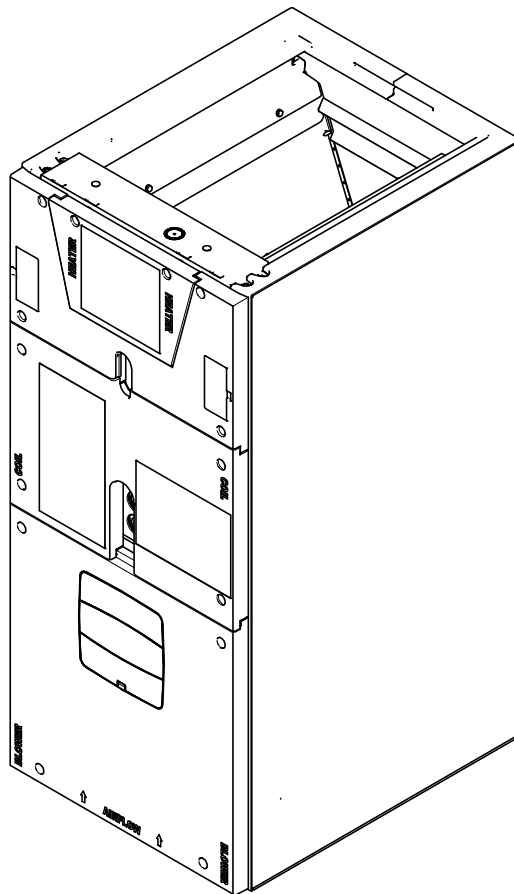

PUB. NO. 22-1858-07



Features and Benefits

- Unique Cabinet Design
 - Double Wall Foamed and Formed Cabinet System
 - Water Proof Cabinet Design
 - R-4.2 Insulating Value (Avg. Insulating Value R-8)
 - Composite Foamed Cabinet Doors
 - Sweat Eliminating Cabinet Design
 - Loose Fiber Eliminating Cabinet Design
 - Smooth Cleanable Cabinet Design
 - 2% or Less air leakage
 - Precision Applied Durable Door Seals
- Multi-Position Upflow/ Horizontal Left / Horizontal Right
- Front Return Option
- Braze in Refrigerant Connection
- Primary/Secondary Condensate Connections
- Vortica Blower with Integrated Slide Deck for Easy Removal
- Polarized Plug connections on Blower
- Aluminum Coil with Integrated Slide Deck for Easy Removal
- Slide in Electric Heaters
- Polarized Plug connections for Electric Heater
- Labeled Panels and connections
- Guide for 1-1/4" to 1" And 3/4" to 1/2" Conduit connection on Top
- R-410A Thermal Expansion Valve (TXV)
- Convertible to R-22 using optional accessory TXV conversion kit.
- Low Voltage Color Coded Wires
- Enhanced Coil Fin Patented
- Blow Through Design
- PSC 3 Speed Motor
- Maximum Width of 17.5"
- Compact 20.8" depth with doors removed
- Integrated Horizontal Drain pans
- Single Color
- Fused 24V Power
- **5 year warranty**
- **10-year warranty registered**
- **Optional extended warranty available**



Contents

Features and Benefits	2
Optional Equipment	4
Unique Cabinet Design Features and Benefits	5
General Data	6
GAF2A0A18S11SE	6
GAF2A0A24S21SE	6
GAF2A0A30S21SE	6
GAF2A0A36S31SE	6
Performance Data	7
Electrical Data	11
Wiring Diagrams	13
Field Wiring	14
Convertibility	16
Dimensions	17



Optional Equipment

OPTIONAL EQUIPMENT FOR GAF2 AIR HANDLERS

Accessory Number	Description	Fits Cabinet Size
BAYECAA05LG1A	Electric Heater, 5kW, Lugs, 24V Control, 1 Ph	A
BAYECAA08LG1A	Electric Heater, 8kW, Lugs, 24V Control, 1 Ph	A
BAYECAA10LG1A	Electric Heater, 10kW, Lugs, 24V Control, 1 Ph	A
BAYSFSCABAA	Supply Duct Flange A1 ①	A1 ①
BAYRETFLGAA	Return Duct Flange A	A
TASB175SB	Plenum Stand with Sound Baffle A	A
BAYFRKIT100 ③	Front Return Kit	A
BAYBRFBX100 ②	Bottom Return Filter Box	A
BAYWMKIT001	Wall Mount Kit	A
BAYLVKIT100A	Low Voltage Conduit Entry Kit	A
BAYAHTXV1836	R-22 TXV Conversion Kit	A
BAYSRKIT100A	Side Return Kit	A
MITISRKIT1620 ②	Side Return Kit with 16" x 20" Filter	A
BAYFLR1620A	High Velocity Filter Kit, 16" X 20' X 1" (10 filters)	A
TASSBK175	Sound Baffle Kit 17.5" Cabinet	A
① GAF2A0A18-36 Cabinet is one piece 17.5" wide ② Uses 16" x 20" filter ③ Uses 16" x 16" filter		

Unique Cabinet Design Features and Benefits

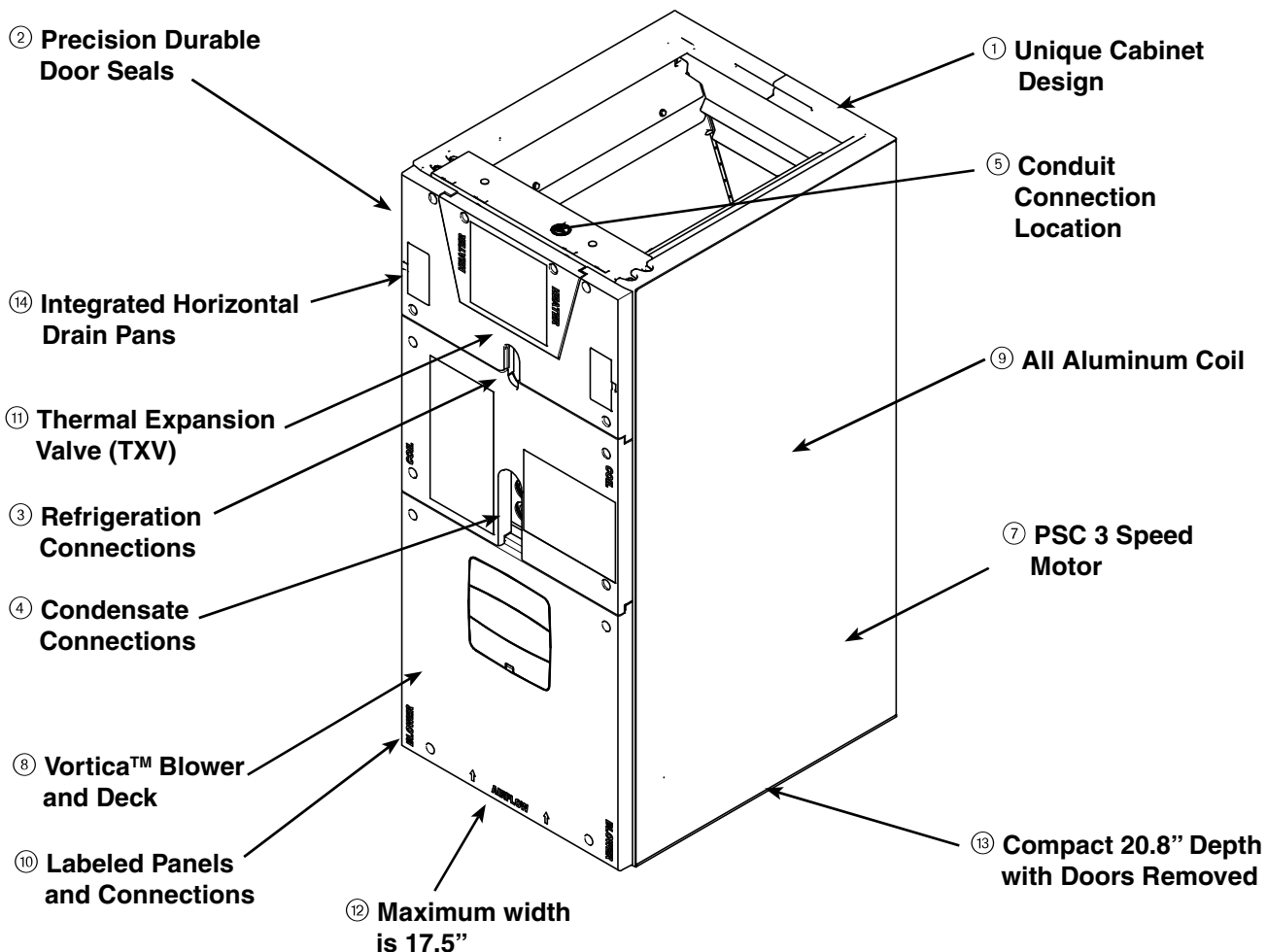

① Unique Cabinet Design

- Double wall foamed cabinet system
- Waterproof Cabinet Design
- R-4.2 Insulating Value (Avg. Insulating Value R-8)
- Composite Foamed Cabinet Doors
- Sweat Eliminating Cabinet Design
- Loose Fiber Eliminating Design
- Smooth Cleanable Cabinet Design
- 2% or Less air leakage

② Precision Durable Door Seals

③ Brazed Refrigeration Connections

④ Primary/Secondary Condensate Connections

⑤ Conduit Connection - Conduit Connection on Top

⑦ PSC 3 Speed Motor

⑧ Vortica™ Blower and Deck - Polarized Plug on Blower

⑨ All Aluminum Coil

- Integrated Slide Deck for Easy Removal
- Polarized Plug connections on Coil TXV
- Patented Enhanced Coil Fin

⑩ Labeled Panels and Connections

⑪ R-410A Thermal Expansion Valve (TXV)

⑫ Maximum width is 17.5"

⑬ Compact 20.8" Depth with Doors Removed

⑭ Integrated Horizontal Drain Pans



TRANE®

General Data

PRODUCT SPECIFICATIONS

MODEL	GAF2A0A18S11SE	GAF2A0A24S21SE	GAF2A0A30S21SE	GAF2A0A36S31SE
RATED VOLTS/PH/HZ.	208-230/1/60	208-230/1/60	208-230/1/60	208-230/1/60
RATINGS ①	See O.D. Specifications	See O.D. Specifications	See O.D. Specifications	See O.D. Specifications
INDOOR COIL — Type	Plate Fin	Plate Fin	Plate Fin	Plate Fin
Rows — F.P.I.	3 - 14	3 - 14	3 - 14	3 - 14
Face Area (sq. ft.)	3.21	3.21	3.21	3.21
Tube Size (in.)	3/8	3/8	3/8	3/8
Refrigerant Control	TXV	TXV	TXV	TXV
Drain Conn. Size (in.) ②	3/4 NPT	3/4 NPT	3/4 NPT	3/4 NPT
DUCT CONNECTIONS	See Outline Drawing	See Outline Drawing	See Outline Drawing	See Outline Drawing
INDOOR FAN — Type	Centrifugal	Centrifugal	Centrifugal	Centrifugal
Diameter-Width (In.)	11 X 8	10 X 8	10 X 8	11 X 8
No. Used	1	1	1	1
Drive - No. Speeds	Direct - 3	Direct - 3	Direct - 3	Direct - 3
CFM vs. in. w.g.	See Fan Performance Table	See Fan Performance Table	See Fan Performance Table	See Fan Performance Table
No. Motors — H.P.	1 - 1/3	1 - 1/4	1 - 1/3	1 - 1/2
Motor Speed RPM	825	1075	1075	1075
Volts/Ph/Hz	208-230/1/60	208-230/1/60	208-230/1/60	208-230/1/60
F.L. Amps - L.R. Amps	2.0 - 4.1	1.3 - 2.6	1.7 - 3.5	2.4 - 3.8
FILTER				
Filter Furnished?	No	No	No	No
Type Recommended	Throwaway	Throwaway	Throwaway	Throwaway
No.-Size-Thickness	1 - 16 X 20 - 1 in.	1 - 16 X 20 - 1 in.	1 - 16 X 20 - 1 in.	1 - 16 X 20 - 1 in.
REFRIGERANT	R-410A ③	R-410A ③	R-410A ③	R-410A ③
Ref. Line Connections	Brazed	Brazed	Brazed	Brazed
Coupling or Conn. Size — in. Gas	3/4	3/4	3/4	3/4
Coupling or Conn. Size — in. Liq.	3/8	3/8	3/8	3/8
DIMENSIONS				
Crated (In.)	H x W x D 40.5 x 20 x 24.5	H x W x D 40.5 x 20 x 24.5	H x W x D 40.5 x 20 x 24.5	H x W x D 40.5 x 20 x 24.5
Uncrated	39.5 x 17.5 x 21.8	39.5 x 17.5 x 21.8	39.5 x 17.5 x 21.8	39.5 x 17.5 x 21.8
WEIGHT				
Shipping (Lbs.)/Net (Lbs.)	117/107	120/110	121/111	122/112

① These Air Handlers are AHRI certified with various Split System Air Conditioners and Heat Pumps (AHRI STANDARD 210/240). Refer to the Split System Outdoor Unit Product Data Guides for performance data.

② 3/4" Male Plastic Pipe (Ref.: ASTM 1785-76)

③ R-22 requires TXV change. Use R-22 TXV conversion kit BAYATXV1836A.



General Data

GAF2A0A18 AIRFLOW PERFORMANCE TABLE

AIRFLOW PERFORMANCE						
GAF2A0A18S11SE						
EXTERNAL STATIC (in w.g)	AIRFLOW (CFM)					
	Speed Taps - 230 VOLTS			Speed Taps - 208 VOLTS		
	3	2 †	1	3	2 †	1
0	952	768	710	940	654	598
0.1	894	741	687	885	636	581
0.2	845	704	658	831	610	558
0.3	785	662	620	775	577	526
0.4	724	607	568	714	529	477
0.5	652	531	494	640	460	415
0.6	557	441	404	543	378	347
0.7	428	346	N/A	418	244	N/A
0.8	284	N/A	N/A	225	N/A	N/A
0.9	N/A	N/A	N/A	N/A	N/A	N/A
1.0	N/A	N/A	N/A	N/A	N/A	N/A

NOTES:
 1. Values are with wet coil and without filters.
 2. Contact your particular filter manufacturer for pressure drop data.
 3. Electric heater pressure drop is negligible and is included within the airflow data.
 4. † Factory Setting

GAF2A0A18S11SE MINIMUM HEATER AIRFLOW CFM		
Heater	Minimum Air Speed Tap	
	Without Heat Pump	With Heat Pump
BAYECAA05LG1AA	Tap 1	Tap 3
BAYECAA08LG1AA	Tap 2	Tap 3
BAYECAA10LG1AA	Tap 2	Tap 3

SEE AIR HANDLER NAMEPLATE OR PRODUCT DATA FOR EXCEPTIONS

Note: Heating and cooling speeds are the same, factory set at Speed Tap #2.



TRANE®

Performance Data

GAF2A0A24 AIRFLOW PERFORMANCE TABLE

AIRFLOW PERFORMANCE						
GAF2A0A24S21SE						
EXTERNAL STATIC (in w.g)	AIRFLOW (CFM)					
	Speed Taps - 230 VOLTS			Speed Taps - 208 VOLTS		
	3	2 †	1	3	2 †	1
0	998	848	771	899	737	658
0.1	949	816	745	868	710	630
0.2	911	784	711	834	683	602
0.3	869	750	679	794	650	567
0.4	825	708	638	756	611	524
0.5	772	659	586	704	547	476
0.6	707	591	518	641	499	415
0.7	614	513	444	555	420	346
0.8	533	416	356	465	339	268
0.9	413	309	218	351	203	138
1.0	241	130	N/A	167	N/A	N/A

NOTES:
 1. Values are with wet coil and without filters.
 2. Contact your particular filter manufacturer for pressure drop data.
 3. Electric heater pressure drop is negligible and is included within the airflow data.
 4. † Factory Setting

GAF2A0A24S21SE MINIMUM HEATER AIRFLOW CFM		
Heater	Minimum Air Speed Tap	
	Without Heat Pump	With Heat Pump
BAYECAA05LG1AA	Tap 1	Tap 2
BAYECAA08LG1AA	Tap 2	Tap 3
BAYECAA10LG1AA	Tap 1	Tap 3
SEE AIR HANDLER NAMEPLATE OR PRODUCT DATA FOR EXCEPTIONS		

Note: Heating and cooling speeds are the same, factory set at Speed Tap #2.



Performance Data

GAF2A0A30 AIRFLOW PERFORMANCE TABLE

AIRFLOW PERFORMANCE						
GAF2A0A30S21SE						
EXTERNAL STATIC (in w.g)	Speed Taps - 230 VOLTS			Speed Taps - 208 VOLTS		
	3	2 †	1	3	2	1
0	1052	967	932	1024	877	826
0.1	1012	929	898	980	846	800
0.2	963	888	861	934	814	771
0.3	914	849	823	885	777	738
0.4	865	805	784	837	739	703
0.5	816	759	741	788	697	663
0.6	759	698	681	739	640	602
0.7	690	622	592	668	559	515
0.8	589	503	463	559	423	395
0.9	389	336	318	375	285	259
1.0	179	149	119	175	NA	NA

NOTES:

1. Values are with wet coil and without filters.
2. Contact your particular filter manufacturer for pressure drop data.
3. Electric heater pressure drop is negligible and is included within the airflow data.
4. † Factory Setting

GAF2A0A30S21SE MINIMUM HEATER AIRFLOW CFM		
Heater	Minimum Air Speed Tap	
	Without Heat Pump	With Heat Pump
BAYECAA05LG1AA	Tap 1	Tap 1
BAYECAA08LG1AA	Tap 2	Tap 2
BAYECAA10LG1AA	Tap 1	Tap 3
SEE AIR HANDLER NAMEPLATE OR PRODUCT DATA FOR EXCEPTIONS		

Note: Heating and cooling speeds are the same, factory set at Speed Tap #2.



TRANE®

Performance Data

GAF2A0A36 AIRFLOW PERFORMANCE TABLE

AIRFLOW PERFORMANCE						
GAF2A0A36S31SE						
EXTERNAL STATIC (in w.g)	Speed Taps - 230 VOLTS			Speed Taps - 208 VOLTS		
	3	2 †	1	3	2	1
0	1191	1146	1094	1040	1015	964
0.1	1180	1132	1085	1033	1004	959
0.2	1158	1110	1065	1014	984	942
0.3	1119	1082	1035	979	958	916
0.4	1079	1045	1003	942	923	887
0.5	1040	1005	969	907	886	857
0.6	993	960	927	864	843	818
0.7	934	910	877	808	795	772
0.8	880	855	816	758	742	715
0.9	815	786	748	696	675	650
1.0	744	715	677	629	607	583

NOTES:
 1. Values are with wet coil and without filters.
 2. Contact your particular filter manufacturer for pressure drop data.
 3. Electric heater pressure drop is negligible and is included within the airflow data.
 4. † Factory Setting

GAF2A0A36S31SE MINIMUM HEATER AIRFLOW CFM		
Heater	Minimum Air Speed Tap	
	Without Heat Pump	With Heat Pump
BAYECAA05LG1AA	Tap 1	Tap 1
BAYECAA08LG1AA	Tap 1	Tap 1
BAYECAA10LG1AA	Tap 1	Tap 1

SEE AIR HANDLER NAMEPLATE OR PRODUCT DATA FOR EXCEPTIONS

Note: Heating and cooling speeds are the same, factory set at Speed Tap #2.



TRANE®

Electrical Data

WIRING DATA											
GAF2A0A18S11SE											
Heater Model No.	No. of Circuits	240 VOLT					208 VOLT				
		Capacity		Heater Amps per Circuit	Minimum Circuit Ampacity	Maximum Overload Protection	Capacity		Heater Amps per Circuit	Minimum Circuit Ampacity	Maximum Overload Protection
		kW	BTUH				kW	BTUH			
No Heater	-	-	-	2.0**	3	15	-	-	2.0**	3	15
BAYECAA05++	1	4.80	16400	20	28	30	3.60	12300	17.3	24	25
BAYECAA08++	1	7.68	26200	32	43	45	5.76	19700	27.7	37	40
BAYECAA10++	1	9.60	32800	40	53	60	7.20	24600	34.6	46	50

Note: ** Motor Amps

WIRING DATA											
GAF2A0A24S21SE											
Heater Model No.	No. of Circuits	240 VOLT					208 VOLT				
		Capacity		Heater Amps per Circuit	Minimum Circuit Ampacity	Maximum Overload Protection	Capacity		Heater Amps per Circuit	Minimum Circuit Ampacity	Maximum Overload Protection
		kW	BTUH				kW	BTUH			
No Heater	-	-	-	1.3**	2	15	-	-	1.3**	2	15
BAYECAA05++	1	4.80	16400	20	27	30	3.60	12300	17.3	23	25
BAYECAA08++	1	7.68	26200	32	42	45	5.76	19700	27.7	38	40
BAYECAA10++	1	9.60	32800	40	52	60	7.20	24600	34.6	45	45

Note: ** Motor Amps

WIRING DATA											
GAF2A0A30S21SE											
Heater Model No.	No. of Circuits	240 VOLT					208 VOLT				
		Capacity		Heater Amps per Circuit	Minimum Circuit Ampacity	Maximum Overload Protection	Capacity		Heater Amps per Circuit	Minimum Circuit Ampacity	Maximum Overload Protection
		kW	BTUH				kW	BTUH			
No Heater	-	-	-	1.7**	2	15	-	-	1.7**	2	15
BAYECAA05++	1	4.80	16400	20	27	30	3.60	12300	17.3	24	25
BAYECAA08++	1	7.68	26200	32	42	45	5.76	19700	27.7	38	40
BAYECAA10++	1	9.60	32800	40	52	60	7.20	24600	34.6	45	45

Note: ** Motor Amps



TRANE®

Electrical Data

WIRING DATA											
GAF2A0A36S31SE											
Heater Model No.	No. of Circuits	240 VOLT					208 VOLT				
		Capacity		Heater Amps per Circuit	Minimum Circuit Ampacity	Maximum Overload Protection	Capacity		Heater Amps per Circuit	Minimum Circuit Ampacity	Maximum Overload Protection
		kW	BTUH				kW	BTUH			
No Heater	-	-	-	2.4**	3	15	-	-	2.4**	3	15
BAYECAA05++	1	4.80	16400	20	28	30	3.60	12300	17.3	25	25
BAYECAA08++	1	7.68	26200	32	43	45	5.76	19700	27.7	38	40
BAYECAA10++	1	9.60	32800	40	53	60	7.20	24600	34.6	46	50

Note: ** Motor Amps

DISTANCE FROM BELLY BAND TO SHAFT FACE OF MOTOR FOR MINIMUM VIBRATION

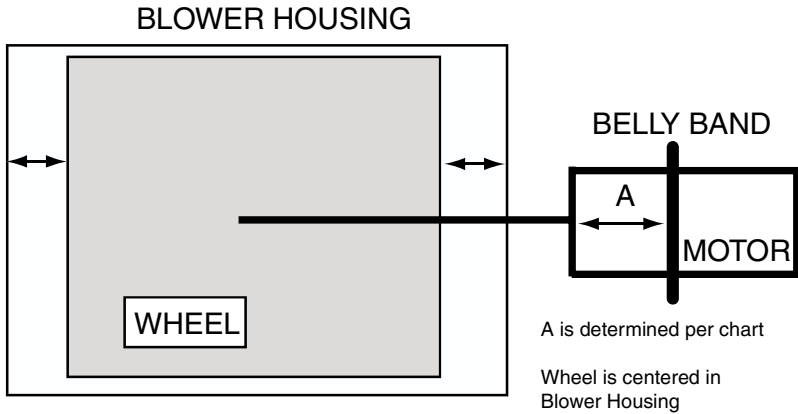

MODEL	DIM "A"
GAF2A0A18S11SE	1-1/8
GAF2A0A24S21SE	2-11/16
GAF2A0A30S21SE	1-9/16
GAF2A0A36S31SE	1-11/16

WIRING DIAGRAM FOR GAF2A0A18S, GAF2A0A24S, GAF2A0A30S, AND GAF2A0A36S AIR HANDLERS

⚠ WARNING
 HAZARDOUS VOLTAGE!
 DISCONNECT ALL ELECTRICAL POWER INCLUDING REMOTE DISCONNECTS BEFORE SERVICING.
 Failure to disconnect power before servicing can cause severe personal injury or death.

⚠ CAUTION
 USE COPPER CONDUCTORS ONLY!
 UNIT TERMINALS ARE NOT DESIGNED TO ACCEPT OTHER TYPES OF CONDUCTORS.
 Failure to do so may cause damage to the equipment.

ELECTRIC HEAT CONTROL (OPTIONAL ACCESSORY KIT11)

TO POWER SUPPLY PER UNIT MANUFACTURE AND LOCAL CODES

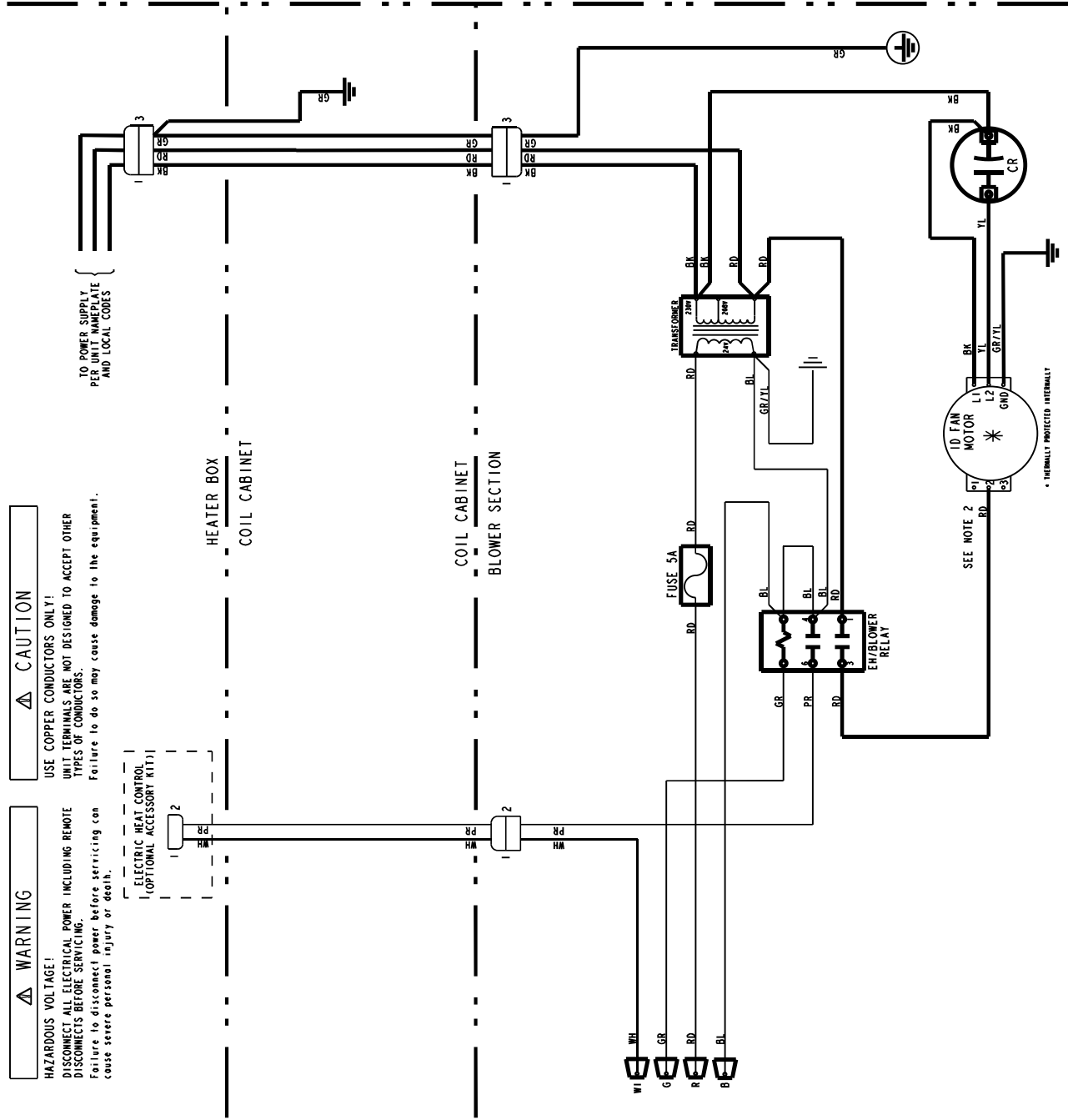

LEGEND

- 24 V. LINE V. } FACTORY WIRING
- 24 V. LINE V. } FIELD WIRING
- MAGNETIC COIL
- GROUND
- JUNCTION
- CAPACITOR
- WIRE NUT OR CONNECTOR
- TERMINAL
- TRANSFORMER
- FUSE
- TERMINAL BLOCK/BOARD
- RELAY CONTACT (N.O.)
- RUN CAPACITOR
- CR
- EH
- ELECTRIC HEAT

- POL. PLUG FEMALE HOUSING (MALE TERM.)
- POL. PLUG MALE HOUSING (FEMALE TERM.)
- COLOR OF WIRE
 - BK/BL BLACK WIRE WITH BLUE MARKER
 - BK BLACK OR ORANGE
 - BL BLUE OR RED
 - BR BROWN WH WHITE
 - GR/YL GREEN YELLOW
- COLOR OF MARKER
 - YL YELLOW
 - GR GREEN
 - PR PURPLE

NOTES:
 1. FOR 208V OPERATION MOVE THE BLACK TRANSFORMER LEAD TO THE 208V CENTER TRANSFORMER TERMINAL.
 2. SPEED TAPS SHOWN ARE FOR REFERENCE ONLY. SEE INSTALLERS GUIDE FOR RECOMMENDED SPEED SETTINGS IN YOUR APPLICATION. (1-LOW, 2-MED, 3-HIGH)



TRANE®

Field Wiring

GAF2 AIR HANDLERS WITH SINGLE SPEED COOLING

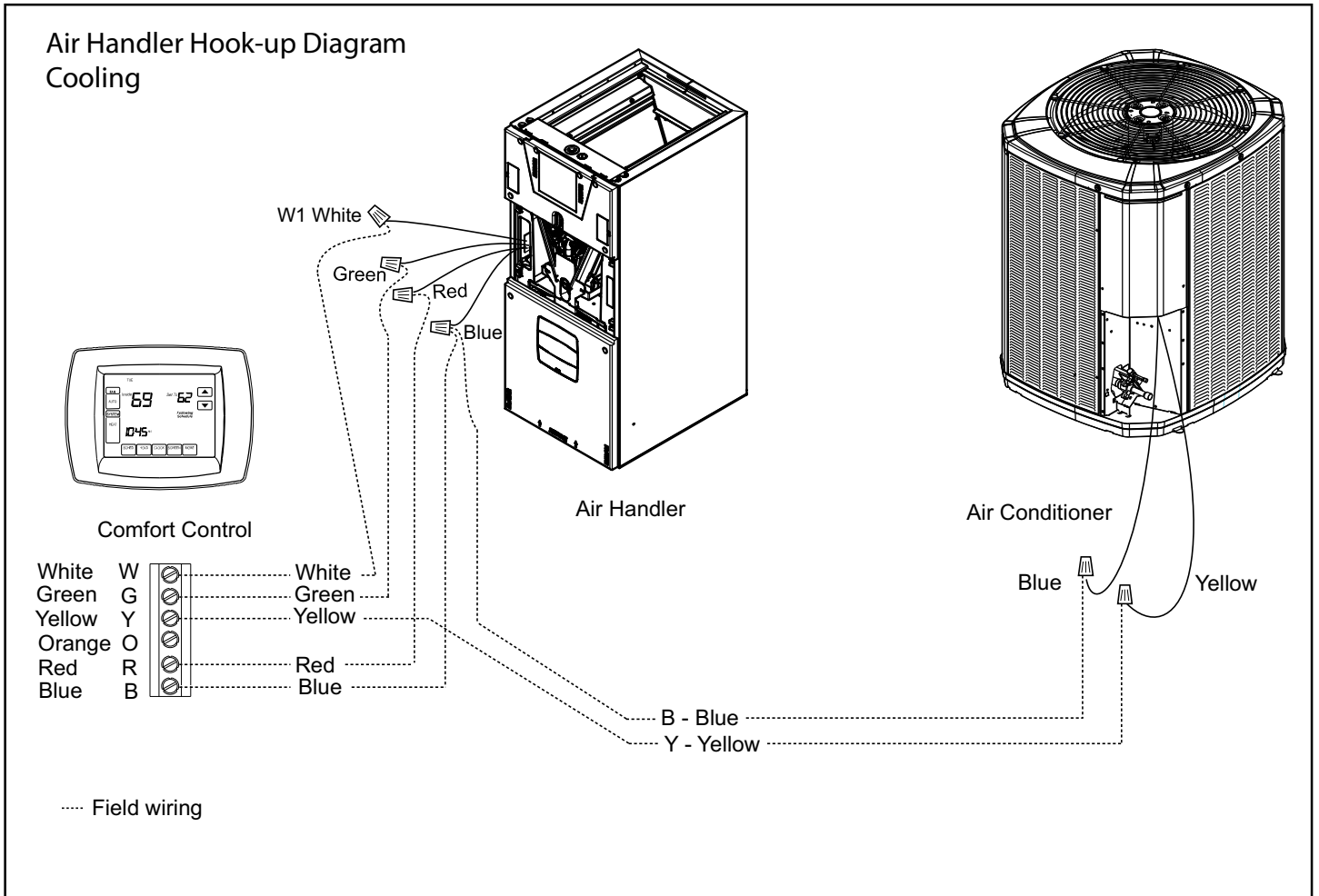

Field Wiring

GAF2 AIR HANDLERS WITH SINGLE SPEED HEAT PUMP

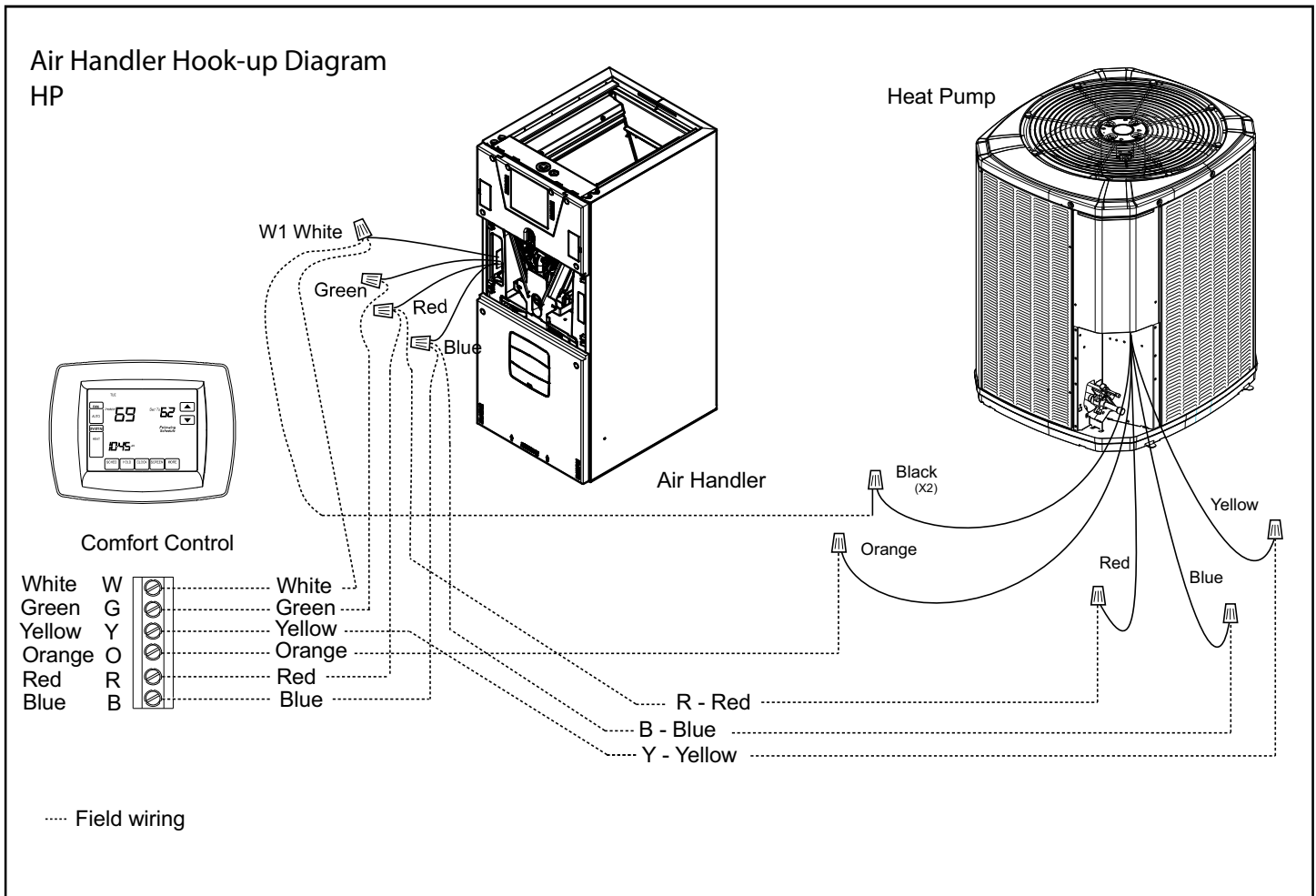



TRANE®

GAF2 Convertibility

* Note: No internal modifications required for any position.

① Badge rotation will keep brand in correct position

Multi-position Air Handler

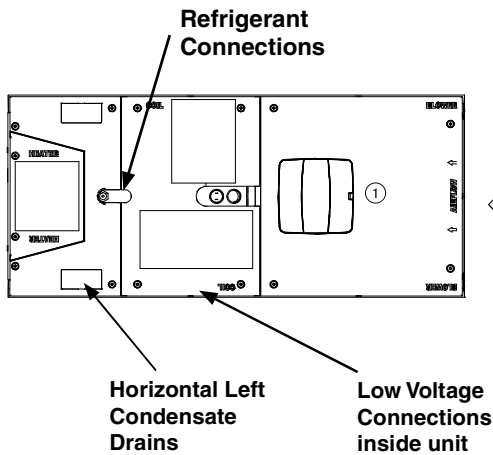
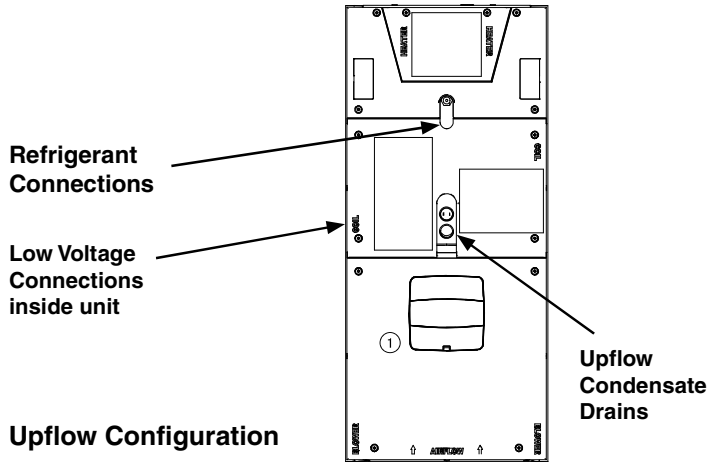

Horizontal Left*

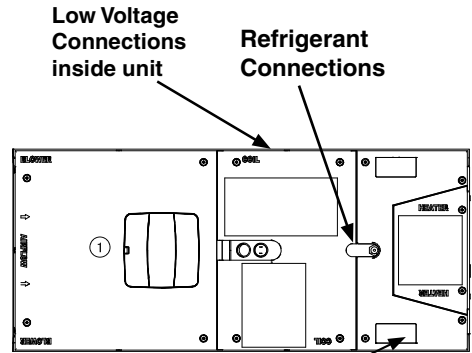

Horizontal Right*

Dimensions

GAF2 AIR HANDLER DIMENSIONAL DATA

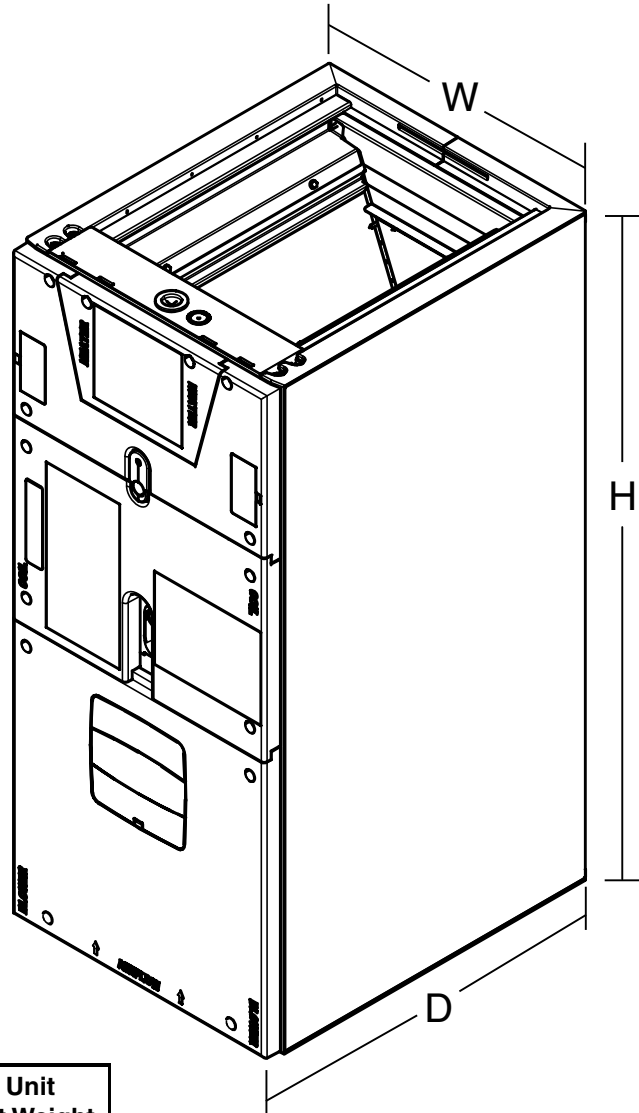

Model Number	H x D x W in.	Unit Net Weight lbs.
GAF2A0A18S11SE	39 x 22 x 17.5	107
GAF2A0A24S21SE	39 x 22 x 17.5	110
GAF2A0A30S21SE	39 x 22 x 17.5	111
GAF2A0A36S31SE	39 x 22 x 17.5	112

GAF2 AIR HANDLERS ARE ALL ONE PIECE CABINETS.

GAF2 OUTLINE DRAWING

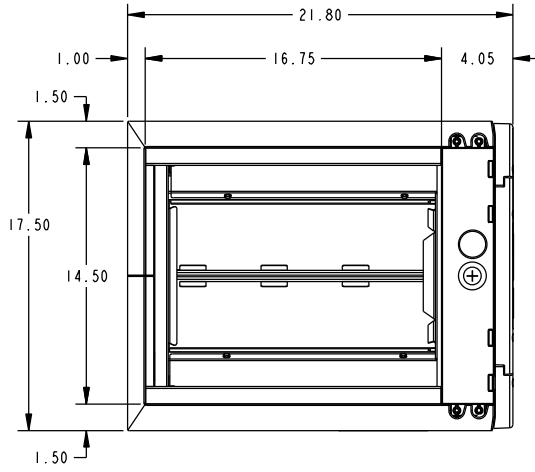

MINIMUM UNIT CLEARANCE TABLE		
	TO COMBUSTIBLE MATERIAL (REQUIRED)	SERVICE CLEARANCE (RECOMMENDED)
SIDES	0"	2"
FRONT	0"	21"
BACK	0"	0"
INLET DUCT	0"	N/A
OUTLET DUCT	0"	N/A

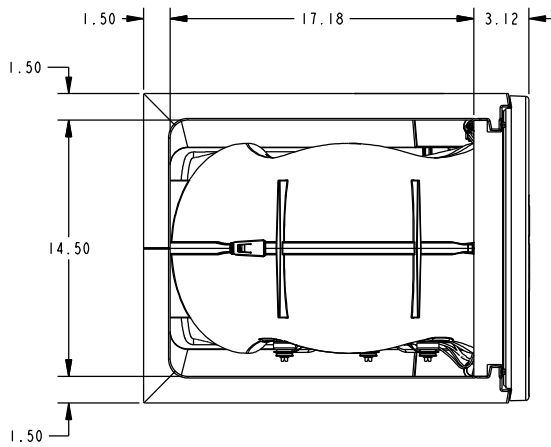
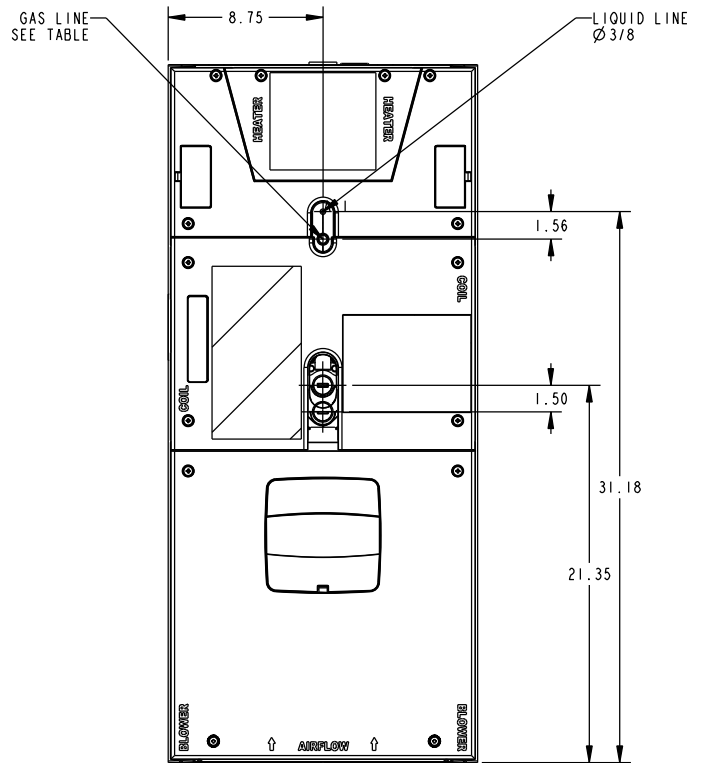
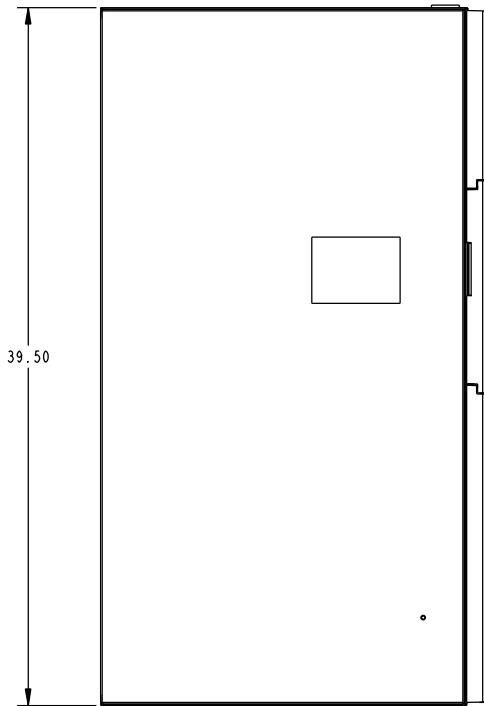

MODEL NO.	FLOW CONTROL	LIQUID LINE BRAZE	GAS LINE BRAZE
GAF2A0A18*	TXV	3/8	3/4
GAF2A0A24*	TXV	3/8	3/4
GAF2A0A30*	TXV	3/8	3/4
GAF2A0A36S*	TXV	3/8	3/4
GAF2A0A36M*	EEV / 24V	3/8	3/4





07/14

Trane
6200 Troup Highway
Tyler, TX 75707
www.trane.com

The manufacturer has a policy of continuous product and product data improvement and it reserves the right to change design and specifications without notice.