

TAG: _____

Submittal

Wall-Mount Air Handlers 1-1/2 – 3 Ton Cooling/ Heat Pump

(Limited heat pump combinations. See AHRI for details.)

- TMM4A0A18S21SA
- TMM4A0A24S21SA
- TMM4A0B30S21SA
- TMM4A0B36S31SA

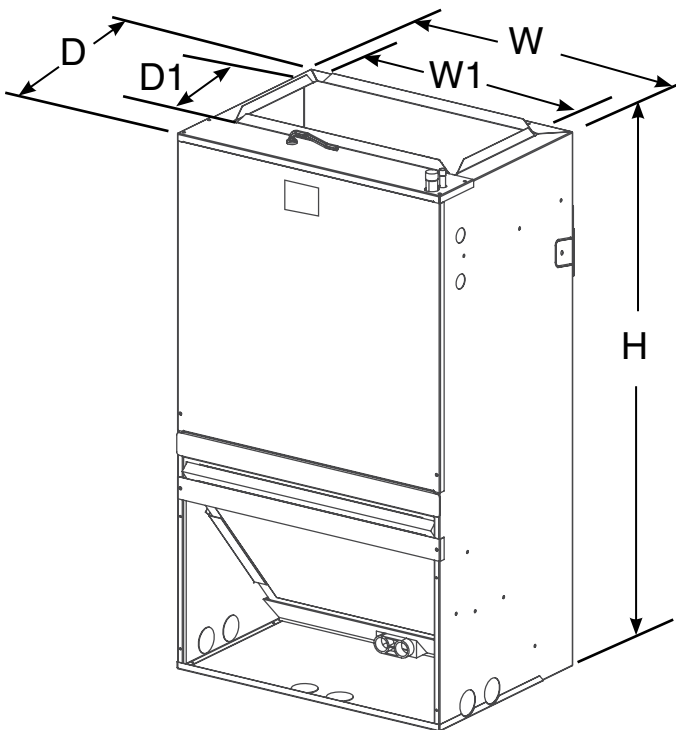

Dimensional and Clearance Data

MINIMUM UNIT CLEARANCE TABLE		
	TO COMBUSTIBLE MATERIAL (REQUIRED)	SERVICE CLEARANCE (RECOMMENDED)
SIDES	0"	0"
FRONT	0"	24"
BACK	0"	0"
INLET DUCT	0"	0"
OUTLET DUCT	0**	
* 0" FOR THE FIRST 3 FT. OF OUTLET DUCT WHEN ELECTRIC HEATERS ARE INSTALLED		

	PRODUCT DIMENSIONS inch (mm)						Flow Control	Gas Line Braze	Unit weight/ Shipping Weight [LBS(kg)]
	Height H	Width W	Width W1	Depth D	Depth D1				
TMM4A0A18S21SA	36-1/2" (928)	20-1/2" (522)	16-5/8" (422)	15" (381)	9-1/2" (242)	FCCV	3/4"	88/99 (40/45)	
TMM4A0A24S21SA	36-1/2" (928)	20-1/2" (522)	16-5/8" (422)	15" (381)	9-1/2" (242)	FCCV	3/4"	88/99 (40/45)	
TMM4A0B30S21SA	39-1/2" (1004)	22" (559)	18-3/4" (477)	19" (483)	9-1/2" (242)	FCCV	3/4"	104/117 (47/53)	
TMM4A0B36S31SA	39-1/2" (1004)	22" (559)	18-3/4" (477)	19" (483)	9-1/2" (242)	FCCV	3/4"	104/117 (47/53)	

Performance and Electrical Data – TMM4A0A18–B36

AIR FLOW PERFORMANCE (Standard CFM)

MODEL NUMBER	MOTOR SPEEDS		EXTERNAL STATIC PRESSURE (INWC.)									
			0	0.1	0.16	0.2	0.3	0.4	0.5	0.6	0.7	0.8
TMM4A0A18S21SA	Low	CFM	590	556	526	520	481	437	387	-	-	-
		RPM	598	645	686	696	745	790	836	-	-	-
		Watts	168	165	161	161	156	150	145	-	-	-
		Amps	0.75	0.73	0.72	0.72	0.7	0.68	0.66	-	-	-
	Middle	CFM	686	650	621	615	578	536	486	-	-	-
		RPM	685	719	749	759	799	837	873	-	-	-
		Watts	184	178	174	174	170	164	158	-	-	-
		Amps	0.81	0.78	0.77	0.77	0.75	0.73	0.71	-	-	-
	High	CFM	796	760	733	725	685	644	596	541	477	400
		RPM	778	805	827	836	867	906	929	956	984	1011
		Watts	236	232	227	227	220	213	205	196	188	179
		Amps	1.04	1.02	1.01	1.00	0.98	0.95	0.92	0.89	0.86	0.83
TMM4A0A24S21SA	Low	CFM	696	662	632	624	583	537	485	-	-	-
		RPM	700	741	767	774	808	843	882	-	-	-
		Watts	198	193	190	188	183	178	170	-	-	-
		Amps	0.89	0.88	0.86	0.86	0.84	0.82	0.8	-	-	-
	Middle	CFM	850	814	775	766	720	672	617	-	-	-
		RPM	837	861	878	885	903	923	945	-	-	-
		Watts	236	231	227	226	221	217	211	-	-	-
		Amps	1.03	1.01	1.00	0.99	0.98	0.96	0.94	-	-	-
	High	CFM	938	894	860	859	813	764	710	674	573	465
		RPM	921	937	950	953	967	980	994	1010	969	1051
		Watts	300	295	289	283	283	277	271	263	254	242
		Amps	1.33	1.31	1.29	1.26	1.26	1.24	1.22	1.19	1.16	1.12
TMM4A0B30S21SA	Low	CFM	997	948	903	891	861	809	760	-	-	-
		RPM	755	789	817	828	846	870	903	-	-	-
		Watts	305	295	287	283	278	271	263	-	-	-
		Amps	1.53	1.51	1.49	1.48	1.47	1.46	1.44	-	-	-
	Middle	CFM	1187	1125	1076	1055	1021	974	912	-	-	-
		RPM	875	899	916	924	935	952	967	-	-	-
		Watts	339	331	324	321	317	309	302	-	-	-
		Amps	1.67	1.66	1.64	1.63	1.62	1.61	1.59	-	-	-
	High	CFM	1306	1249	1195	1166	1132	1069	1008	937	860	759
		RPM	965	968	982	987	994	1007	1015	1027	1041	1054
		Watts	427	417	409	406	400	391	384	375	363	351
		Amps	2.20	2.18	2.16	2.15	2.15	2.13	2.11	2.09	2.07	2.05

Shaded boxes represent airflow outside the required 300-450 cfm/ton.

NOTES:

1. Airflow based upon dry coil at 230V with no electric heat, no filter.
2. Airflow is equivalent for front or bottom return configurations.
3. SCFM is nearly the same with cooling performance airflow, the gap is in the 1 to 2%.

AIR FLOW PERFORMANCE (Standard CFM) (Continued)

MODEL NUMBER	MOTOR SPEEDS		EXTERNAL STATIC PRESSURE (INWC.)									
			0	0.1	0.16	0.2	0.3	0.4	0.5	0.6	0.7	0.8
TMM4A0B36S31SA	Low	CFM	1106	1056	1007	990	960	918	857	-	-	-
		RPM	818	843	868	878	893	916	941	-	-	-
		Watts	371	361	349	346	338	328	316	-	-	-
		Amps	1.62	1.58	1.53	1.52	1.49	1.44	1.40	-	-	-
	Middle	CFM	1269	1213	1153	1131	1097	1069	973	-	-	-
		RPM	920	933	947	956	965	982	997	-	-	-
		Watts	410	401	391	385	380	368	357	-	-	-
		Amps	1.79	1.74	1.70	1.67	1.65	1.60	1.55	-	-	-
	High	CFM	1375	1320	1267	1248	1204	1142	1082	1011	919	801
		RPM	986	996	1007	1011	1018	1030	1040	1051	1063	1079
		Watts	461	450	440	436	427	416	402	388	376	358
		Amps	2.01	1.96	1.92	1.90	1.87	1.91	1.76	1.70	1.65	1.57

Shaded boxes represent airflow outside the required 300-450 cfm/ton.

NOTES:

1. Airflow based upon dry coil at 230V with no electric heat, no filter.
2. Airflow is equivalent for front or bottom return configurations.
3. SCFM is nearly the same with cooling performance airflow, the gap is in the 1 to 2%.

TMM4A0A18S21SA - ELECTRICAL DATA											
Heater Model No	No. of Circuits/ Phases	240 Volt					208 Volt				
		Capacity		Heater Amps per Circuit	Minimum Circuit Ampacity	Maximum Overload Protection	Capacity		Heater Amps per Circuit	Minimum Circuit Ampacity	Maximum Overload Protection
		kW	BTUH				kW	BTUH			
No Heater					1.0	15				1.0	15
BAYHTRM505BRKA	1/1	5	17100	20.8	27.1	30	3.8	12800	18.0	23.6	30
BAYHTRM508BRKA	1/1	7.5	25600	31.2	40.1	50	5.6	19200	27.1	34.9	50
BAYHTRM510BRKA	1/1	10	34100	41.7	53.1	60	7.5	25600	36.1	46.2	60

TMM4A0A24S21SA - ELECTRICAL DATA											
Heater Model No	No. of Circuits/ Phases	240 Volt					208 Volt				
		Capacity		Heater Amps per Circuit	Minimum Circuit Ampacity	Maximum Overload Protection	Capacity		Heater Amps per Circuit	Minimum Circuit Ampacity	Maximum Overload Protection
		kW	BTUH				kW	BTUH			
No Heater					1.3	15				1.3	15
BAYHTRM505BRKA	1/1	5	17100	20.8	27.3	30	3.8	12800	18.0	23.9	30
BAYHTRM508BRKA	1/1	7.5	25600	31.2	40.4	50	5.6	19200	27.1	35.2	50
BAYHTRM510BRKA	1/1	10	34100	41.7	53.4	60	7.5	25600	36.1	46.4	60

TMM4A0B30S21SA - ELECTRICAL DATA											
Heater Model No	No. of Circuits/ Phases	240 Volt					208 Volt				
		Capacity		Heater Amps per Circuit	Minimum Circuit Ampacity	Maximum Overload Protection	Capacity		Heater Amps per Circuit	Minimum Circuit Ampacity	Maximum Overload Protection
		kW	BTUH				kW	BTUH			
No Heater					1.6	15				1.6	15
BAYHTRM505BRKA	1/1	5	17100	20.8	27.7	30	3.8	12800	18.0	24.2	30
BAYHTRM508BRKA	1/1	7.5	25600	31.2	40.7	50	5.6	19200	27.1	35.5	50
BAYHTRM510BRKA	1/1	10	34100	41.7	53.7	60	7.5	25600	36.1	46.8	60

TMM4A0B36S31SA - ELECTRICAL DATA											
Heater Model No	No. of Circuits/ Phases	240 Volt					208 Volt				
		Capacity		Heater Amps per Circuit	Minimum Circuit Ampacity	Maximum Overload Protection	Capacity		Heater Amps per Circuit	Minimum Circuit Ampacity	Maximum Overload Protection
		kW	BTUH				kW	BTUH			
No Heater					2.3	15				2.3	15
BAYHTRM505BRKA	1/1	5	17100	20.8	28.3	30	3.8	12800	18.0	24.9	30
BAYHTRM508BRKA	1/1	7.5	25600	31.2	41.4	50	5.6	19200	27.1	36.2	50
BAYHTRM510BRKA	1/1	10	34100	41.7	54.4	60	7.5	25600	36.1	47.4	60

Mechanical Specifications

STANDARD FEATURES

- Front or bottom return air
- Painted finish on galvanized steel
- Sturdy polycarbonate drain pans
 - The TMM4 wall mount air handler a has factory installed drain pan and is shipped for upflow applications only.
- 208/23- VAC operation
- Multi-speed direct drive blower
 - PSC motor
- Stud or wall mounting tabs
- Fully insulated cabinet
- 3/4" NPT primary and secondary drains
- **3 year warranty**
- **10-year warranty registered**
- **Optional extended warranty available**

OPTIONAL ACCESSORIES

- 5, 7.5, and 10 kW single phase electric heaters
 - Circuit breakers are standard on all single phase 5, 7.5, and 10 kW heaters.
- R-410 TXV kit
- R-22 TXV conversion kit
- Front louver panel 20.5" width
- Front louver panel 22" width
- Return air / service wall panel