

Installer's Guide

WALL-MOUNT AIR HANDLERS

1.5-3TON COOLING/HEAT PUMP

(Limited heat pump combinations. See AHRI for details.)

TMM4A0A18S21SAA

TMM4A0A24S21SAA

TMM4A0B30S21SAA

TMM4A0B36S31SAA

ALL phases of this installation must comply with NATIONAL, STATE AND LOCAL CODES

Important: This Document is customer property and is to remain with this unit.

The TMM4A series wall mount air handler is designed for installation in a closet, utility room, alcove and can be wall mounted. These versatile units are applicable to air conditioning applications. Field installed electric resistance heaters are available.

Section 1. Features

1.1 Standard Features

- FRONT OR BOTTOM RETURN AIR.
- PAINTED FINISH ON GALVANIZED STEEL
- STURDY POLYCARBONATE DRAIN PANS
 - The TMM4A wall mount air handler has factory installed drain pans and is shipped for upflow applications only.
- 208/230 VAC OPERATION
- STUD OR WALL MOUNTING TABS
- FULLY INSULATED CABINET
- 3/4" NPT PRIMARY AND SECONDARY DRAINS

1.2 Optional Accessories

- 5, 7.5 and 10 kW SINGLE PHASE ELECTRIC HEATERS
 - Circuit breakers are standard on all single phase 5, 7.5 and 10 kW heaters.

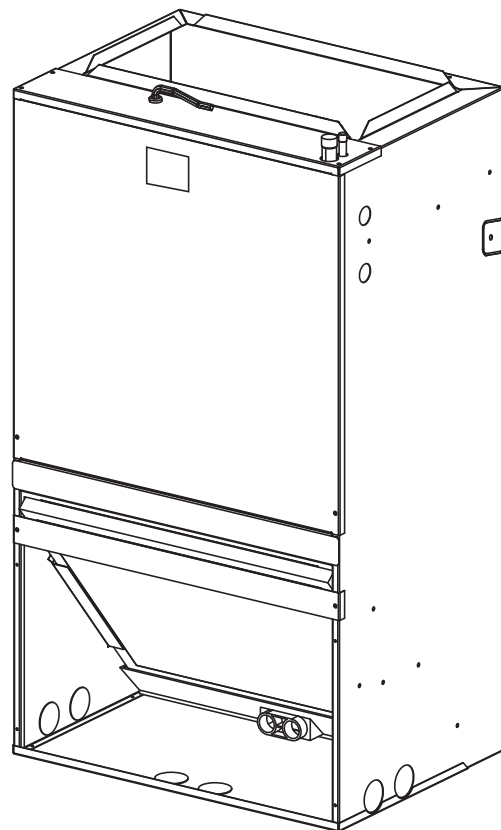

Section 2. Safety Information



WARNING

SAFETY HAZARD! This information is intended for use by individuals possessing adequate backgrounds of electrical and mechanical experience. Any attempt to repair a central air conditioning product may result in personal injury and/or property damage. The manufacturer or seller cannot be responsible for the interpretation of this information, nor can it assume any liability in connection with its use.



WARNING

HAZARDOUS VOLTAGE!

Disconnect all electrical power, including remote disconnects before installing or servicing. Follow proper lockout/tagout procedures to ensure the power can not be inadvertently energized. Failure to disconnect power before servicing could result in death or serious injury.



WARNING

LIVE ELECTRICAL COMPONENTS! During installation, testing, servicing, and troubleshooting of this product, it may be necessary to work with live electrical components. Failure to follow all electrical safety precautions when exposed to live electrical components could result in death or serious injury.



WARNING

EXPLOSION HAZARD!

Do not store corrosive or combustible materials, gasoline, or other flammable vapors or liquids near the unit. Failure to follow this warning could result in property damage, serious personal injury, or death.



WARNING

ELECTRICAL HAZARD!

Grounding Required! Follow proper local and state electrical code on requirements for grounding. Failure to follow this warning could result in property damage, serious personal injury, or death.



WARNING

HAZARDOUS VAPORS! Do not install an air handler with a non-ducted return in the same closet, alcove, or utility room as a fossil fuel device. Hazardous vapors can be distributed throughout the conditioned space and equipment damage can result.

Important: These instructions do not cover all variations in systems nor provide for every possible contingency to be met in connection with the installation. Should further information be desired or should particular problems arise which are not covered sufficiently for the purchaser's purposes, the matter should be referred to your installing dealer or local distributor.

Important: Installation of this unit shall be made in accordance with the National Electric Code, NFPA No. 90A and 90B, and any other local codes or utilities requirements.

Note: The small air handlers have been evaluated in accordance with the Code of Federal Regulations, Chapter XX, Part 3280 or the equivalent. "SUITABLE FOR MOBILE HOME USE."



CAUTION

CORROSION HAZARD! To prevent shortening its service life, the air handler should not be used during the finishing phases of construction. The low return air temperatures can lead to the formation of condensate. Condensate in the presence of chlorides and fluorides from paint, varnish, stains, adhesives, cleaning compounds, and cement creates a corrosive condition which may cause rapid deterioration of the cabinet and internal components.



CAUTION

SAFETY HAZARD! Sharp Edge Hazard. Be careful of sharp edges on equipment or any cuts made on sheet metal while installing or servicing. Personal injury may result.



WARNING

THIS PRODUCT CONTAINS FIBERGLASS WOOL INSULATION! FIBERGLASS DUST AND CERAMIC FIBERS ARE BELIEVED BY THE STATE OF CALIFORNIA TO CAUSE CANCER THROUGH INHALATION. GLASSWOOL FIBERS MAY ALSO CAUSE RESPIRATORY, SKIN, OR EYE IRRITATION.

PRECAUTIONARY MEASURES

- Avoid breathing fiberglass dust
- Use a NIOSH approved dust/mist respirator
- Avoid contact with the skin or eyes. Wear long-sleeved, loose fitting clothing, gloves, and eye protection.
- Wash clothes separately from other clothing, rinse washer thoroughly.
- Operations, such as sawing, blowing, tear-out, and spraying may generate fiber concentrations requiring additional respiratory protection. Use the appropriate NIOSH approved respirator in these situations.

FIRST AID MEASURES

EYE CONTACT: FLUSH EYES WITH WATER TO REMOVE DUST IF SYMPTOMS PERSIST, SEEK MEDICAL ATTENTION.

SKIN CONTACT: WASH AFFECTED AREA GENTLY WITH SOAP AND WARM WATER AFTER HANDLING.

Note: The manufacturer recommends installing ONLY A.H.R.I. approved, matched indoor and outdoor systems. Some of the benefits of installing approved matched indoor and outdoor split systems are maximum efficiency, optimum performance, and the best overall system reliability.



WARNING

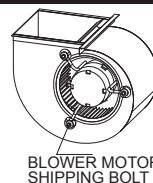

Make sure the blower motor support is tight (3-motor mount bolts) then check to see if wheel is secured to motor shaft before operating unit.

Section 3. Installation Instructions

3.1 Unpacking

Carefully unpack the unit and inspect the contents for damage. If any damage is found at the time of delivery, proper notification and claims should be made with the carrier.

Check the rating plate to assure model number and voltage. Furthermore, check that kits match with what was ordered. The manufacturer should be notified within 5 days of any discrepancy or parts shortage.

3.2 Location

The small air handler should be centrally located and may be installed in a closet, alcove, utility room, or basement. Minimum clearances must be met.

The air handler comes standard with two different options for mounting, wall mount or frame mount. Both mounting options require the unit to be level from side to side and from front to back in order to allow condensate to properly drain from the unit. Failure to do this will result in condensate leaking out from the unit, potentially causing structural damage to the surrounding support structures, dry wall, carpet, etc. Also, both mounting structures require the ability to accommodate a minimum of 150 lb load. Failure to do this will cause damage to the support structure and potentially damage the unit.

3.2.1 WALL MOUNT

The air handler comes standard with an upper and lower wall mount bracket. Reference Figure 3-1 for more detail.

1. Remove lower wall mounting bracket from the back of the unit by removing one screw which attaches the bracket to the air handler. Note: Discard the screw after you have removed the wall mounting bracket.

2. Install bracket on the wall by using 3 wood screws (not provided). Make sure the bracket is level in order to provide proper drainage from the unit. Note: Do not attach the wall mounting bracket into unsupported dry wall. Make sure that the wood screws are going into a structure that can support a minimum load of 150 lb.

3. Lift the air handler above the wall mounting bracket and attach the unit to the installed bracket. Reference Figure 3-1.

4. Install the additional bottom plate for extra support for this type mounting (see figure 3-1).

Note: The additional plate is shipped in the bottom of the shipping carton (only for 30/36k unit).

3.2.2 FRAME MOUNT

The air handler comes with 8 clearance holes (4 on each side). These holes are used to mount the air handler inside of a frame structure (see Figure 3-2). When mounting in this fashion, make sure that the wood screws are mounted from within the air handler and not outside of the unit. Install the screws from outside the unit, and avoid damaging the coil. If the frame does not provide support in the front of the unit and additional support is needed, open up the tabs and fix the unit to the frame or other support structure with screws (only for 30K/36K). Select a solid and level site to ensure proper installation of the frame mount. Verify that there is sufficient space for installation and maintenance. (See Figure. 3-3)

IMPORTANT: The (8) wood screws are not provided with the unit. #12 x 1 1/2" wood screws are recommended. When the unit is installed on a wood frame, the screws should be used to fix the unit to the studs. If they are not used, the unit may fall down or cause other damage. See Figure 3-2 for frame mount installation.

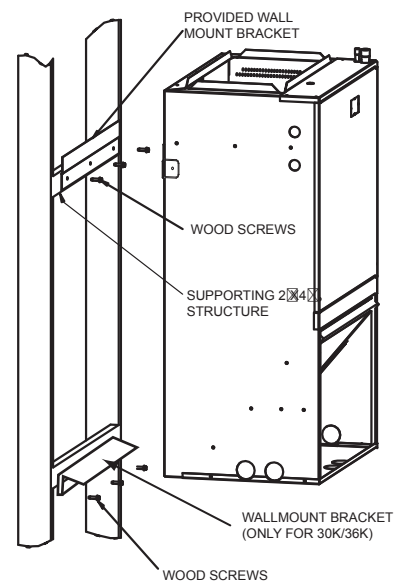
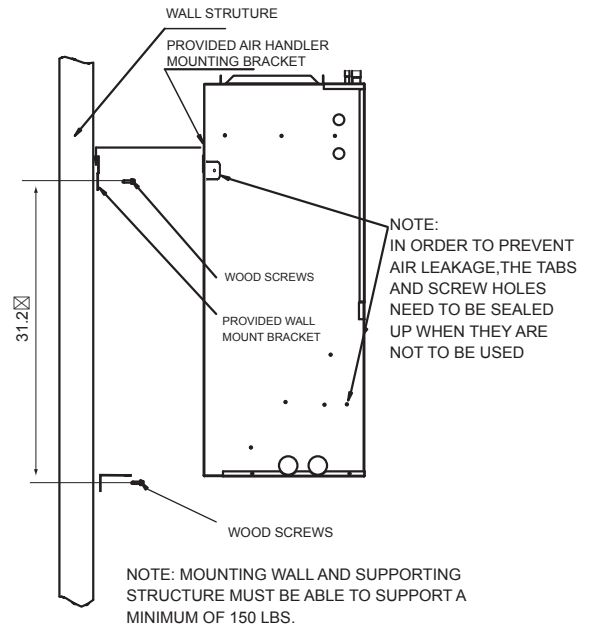

Fig. 3-1 WALL MOUNT

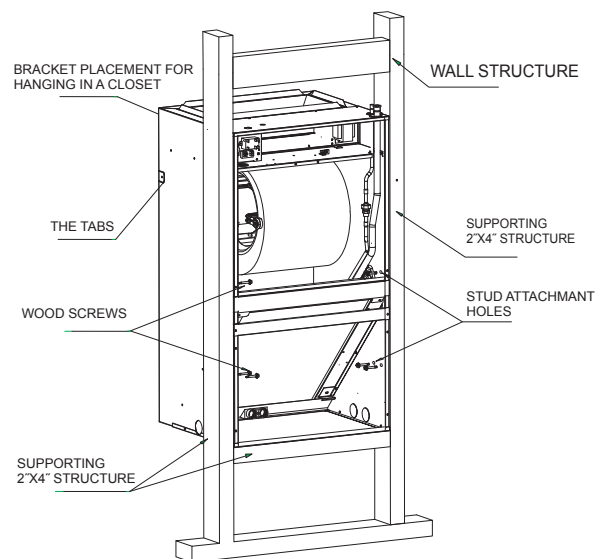
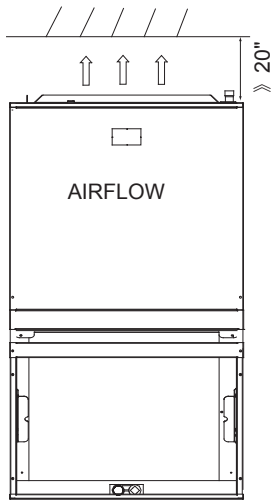

Fig. 3-2 FRAME MOUNT



Top view of the indoor unit clearance(including air duct).

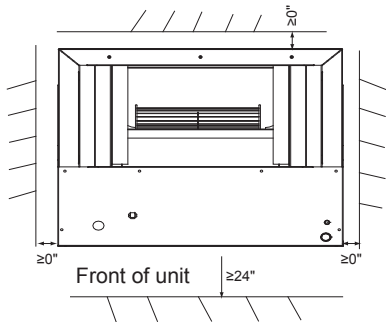

Fig.3-3 Space for frame mount

3.2.3 CONFIGURATIONS

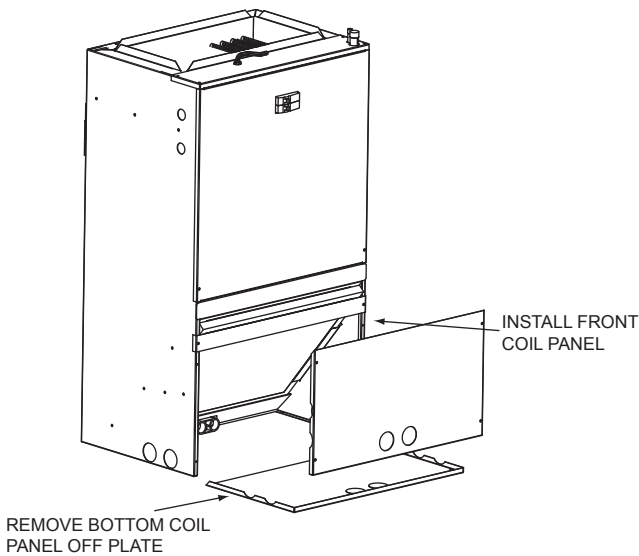

Fig. 3-4 DIFFERENT AIR SUPPLY

Bottom Return Conversion: Divert the return air from the factory standard front return to a bottom return. Remove the cross brace when converting cabinet to bottom return.

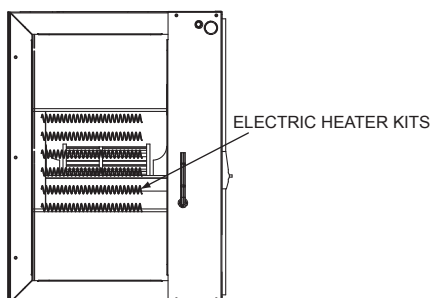

Fig. 3-5 HEATER ELEMENTS INSTALLATION

3.3 Duct Work

Field ductwork must comply with the National Fire Protection Association NFPA 90A, NFPA 90B and any applicable local ordinance.

WARNING

Do not, under any circumstances, connect return ductwork to any other heat producing device such as fireplace insert, stove, etc. Unauthorized use of such devices may result in fire, carbon monoxide poisoning, explosion, personal injury or property damage.

Sheet metal ductwork run in unconditioned spaces must be insulated and covered with a vapor barrier. Fibrous ductwork may be used if constructed and installed in accordance with SMACNA Construction Standard on Fibrous Glass Ducts. Ductwork must comply with National Fire Protection Association as tested by U/L Standard 181 for Class I Air Ducts. Check local codes for requirements on ductwork and insulation.

- Duct system must be designed within the range of external static pressure the unit is designed to operate against. It is important that the system airflow be adequate. Make sure supply and return ductwork, grills, special filters, accessories, etc. are accounted for in total resistance. See airflow performance tables in this manual.
 - Design the duct system in accordance with "ACCA" Manual "D" Design for Residential Winter and Summer Air Conditioning and Equipment Selection. Latest editions are available from: "ACCA" Air Conditioning Contractors of America, 1513 16th Street, N.W., Washington, D.C. 20036. If duct system incorporates flexible air duct, be sure pressure drop information (straight length plus all turns) shown in "ACCA" Manual "D" is accounted for in system.
 - Supply plenum is attached to the 3/4" duct flanges supplied with the unit.
- IMPORTANT:** If an elbow is included in the plenum close to the unit, it must not be smaller than the dimensions of the supply duct flange on the unit.
- **IMPORTANT:** If connected to the blower casing, the front flange on the return duct must not be screwed into the area where the power wiring is located. Drills or sharp screw points can damage insulation on wires located inside unit.
 - Secure the supply and return ductwork to the unit flanges, using proper fasteners for the type of duct used and tape the duct-to-unit joint as required to prevent air leaks.

3.4 Condensate Drain

The unit is supplied with primary and auxiliary condensate drains that have 3/4" NPT connections. Both drains must be trapped outside the unit and piped in accordance with applicable building codes. Do not reduce the drain line size less than the connection size on the drain pan. Condensate should be piped to an open drain or to the outside. All drains must pitch downward away from the unit a minimum of 1/4" per foot of line to ensure proper drainage. Insulate the primary drain line to prevent sweating where dew point temperatures may be met. (Insulation is optional depending on climate and application needs.)

Important: If cleanout Tee is used, standpipe must be sealed/capped.

3.5 Refrigerant Piping

Refrigerant pipe connections are located on the top of the unit. Refrigerant piping external to the unit shall be sized in accordance with the instructions of the outdoor equipment. When units are recessed mounted in the wall, make certain that piping connections are pressure tested prior to the wall being closed. While brazing, be sure to protect the cabinet and grommets from heat damage.

3.6 Metering Device

All units are shipped and installed with throttle designed for air conditioning operation. Pressures equalize after shut down. Some outdoor models may require a start assist kit. See outdoor unit for more information.

3.7 Blower

This unit is supplied with a multi-speed PSC motor with a direct drive blower wheel which can obtain various air flows. The unit is shipped with factory set cooling and heating speed taps. Airflow performance tables are available for additional speed taps. Disconnect all power to the unit before making any adjustments to the motor speed taps. Be sure to check the air flow and the temperature drop across the evaporator coil to ensure sufficient air flow.

3.8 Wiring

Field wiring must comply with the National Electric Code (C.E.C. in Canada) and any applicable local ordinance.



WARNING

Disconnect all power to unit before installing or servicing. More than one disconnect switch may be required to de-energize the equipment. Hazardous voltage can cause severe personal injury or death.

3.8.1 POWER WIRING

It is important that proper electrical power is available for connection to the unit model being installed. See the unit nameplate, wiring diagram and electrical data in the installation instructions.

- If required, install a branch circuit disconnect of adequate size, located within sight of, and readily accessible to the unit.
- **IMPORTANT:** After the Electric Heater is installed, units are equipped with one 30-60 amp. circuit breaker. These breaker(s) protect the internal wiring in the event of a short circuit and serve as a disconnect. Circuit breakers installed within the unit do not provide over-current protection of the supply wiring and therefore may be sized larger than the branch circuit protection.
- Supply circuit power wiring must be 75°C minimum copper conductors only. See Electrical Data in this section for ampacity, wire size and circuit protector requirements. Supply circuit protective devices may be either fuses or "HACR" type circuit breakers.
- Power wiring may be connected to either the right or left side. Two 7/8" dia. concentric knockouts are provided for connection of power wiring to unit.
- Power wiring is connected to the power terminal block in unit electric cabinet.

3.8.2 CONTROL WIRING

IMPORTANT: Class 2 low voltage control wiring should not be run in conduit with main power wiring and must be separated from power wiring, unless class 1 wire of proper voltage rating is used.

- Low voltage control wiring should be 18 Awg. color-coded. For lengths longer than 100 ft., 16 Awg. wire should be used.

- Low voltage control connections are made to low voltage pigtailed extending from top of air handler (see Figure 1). Connections for control wiring are made with wire nuts. Control wiring knockouts (7/8") are also provided on the right and left side of the unit for side connection.
- See wiring diagrams attached to indoor and outdoor sections to be connected.
- Make sure, after installation, separation of control wiring and power wiring has been maintained.

3.8.3 GROUNDING



WARNING

The unit must be permanently grounded. Failure to do so can result in electrical shock causing personal injury or death.

- Grounding may be accomplished when installed in accordance with electrical codes by bonding the metal conduit to the unit cabinet or by attaching ground wire(s) to ground lug(s) provided in the unit wiring compartment.
- Ground lug(s) are located close to wire entrance on left side of unit (upflow). Lug(s) may be moved to marked locations near wire entrance on right side of unit (upflow) if alternate location is more convenient.
- Use of multiple supply circuits require grounding of each circuit to lug(s) provided in unit.

3.9 Air Filter

An air filter must be installed before air enters the evaporator coil in order to protect the coil, blower, and other internal parts from excessive dirt and dust. A filter must be installed. Consult the filter manufacturer for proper sizing and maximum velocity requirements.

Filter Sizes

MODEL	FILTER SIZE IN [mm]
18/24	16X20[406X508]
30/36	20X20[508X508]

3.10 Thermostat

Select a thermostat that is commonly used with HP or AC single stage heating/cooling with electric heat. The thermostat will energize the fan on a demand for heating or cooling.

Install the thermostat on an inside wall, away from drafts, lights or other heat sources in a location that has sufficient air circulation from other rooms being controlled by the thermostat. The thermostat should be mounted 4 to 5 feet above the floor.

3.11 Sequence of Operation

Cooling (cooling only)

When the thermostat calls for cooling, the circuit from R to G is completed. The blower motor is energized directly by the 24VAC signal from the thermostat.

The circuit from R to Y is also completed, energizing the compressor contactor of the outdoor unit. The contactor will close and start the compressor and condenser fan motor.

Heating (electric heat only)

Note: The thermostat must be setup to bring the blower on when the electric heat is energized.

When the thermostat calls for heating, the circuit from R to G is completed and the blower motor is energized directly by the 24VAC signal from the thermostat. The circuit from R to W is completed energizing the heating contactor(s).

3.12 Operational And Checkout Procedures

To obtain proper performance, all units must be operated and charge adjustments made in accordance with procedures found in the Service Facts document of the outdoor unit.

After installation has been completed, it is recommended that the entire system be checked against the following list:

- [] 1. Be sure unit suspension (if used) is secure and there are no tools or loose debris in, around or on top of the unit.
- [] 2. Properly insulate suction lines and fittings.
- [] 3. Properly secure and isolate all refrigerant lines.
- [] 4. Verify that all electrical connections are tight.
- [] 5. Check all duct outlets; they must be open and unrestricted.
- [] 6. Check drain lines and be sure all joints are tight.
- [] 7. Be sure the return air filter is installed.
- [] 8. Operate complete system in each mode to verify proper performance. Verify operation of supplementary electric heater.

3.13 Maintenance

The system air filter(s) should be inspected, cleaned or replaced at least monthly. Make certain that the access panels are replaced and secured properly before placing the unit back in operation. This product is designed for dependable service; however, periodic maintenance should be scheduled and conducted by trained professional service personnel. This service should be conducted at least annually, and should include testing and inspection of electrical and refrigerant components. The heat transfer surface should be cleaned. The blower motor is permanently lubricated for normal operating conditions.

Section 4. Wiring

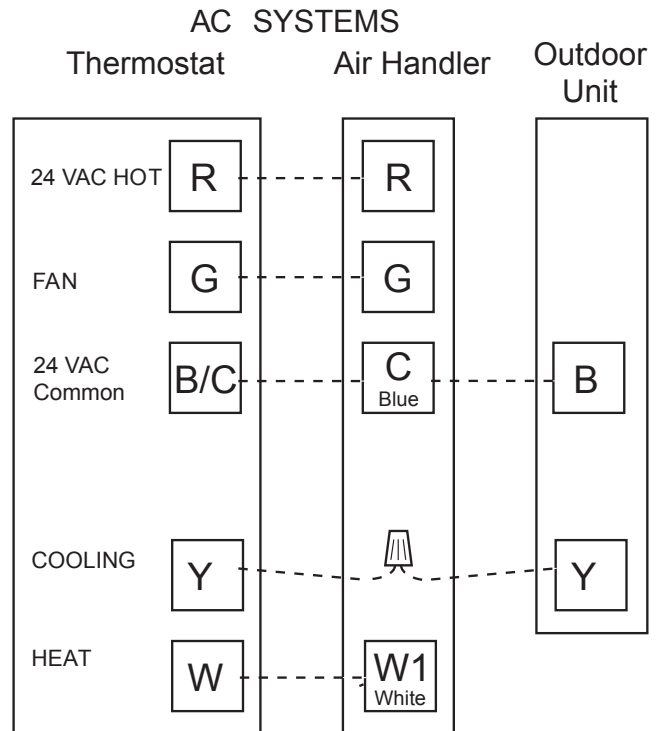

SCHEMATIC DIAGRAM
SEE RATING PLATE FOR VOLTS&HERTZ

CAUTION:
NOT SUITABLE FOR USE ON SYSTEMS EXCEEDING 150V TO GROUND
ATTENTION:
NE CONVIENT PAS AUX INSTALLATIONS DE PLUS DE 150V ALA TERRE

ELECTRIC HEAT WIRING CONNECTION (WHEN APPLIED)

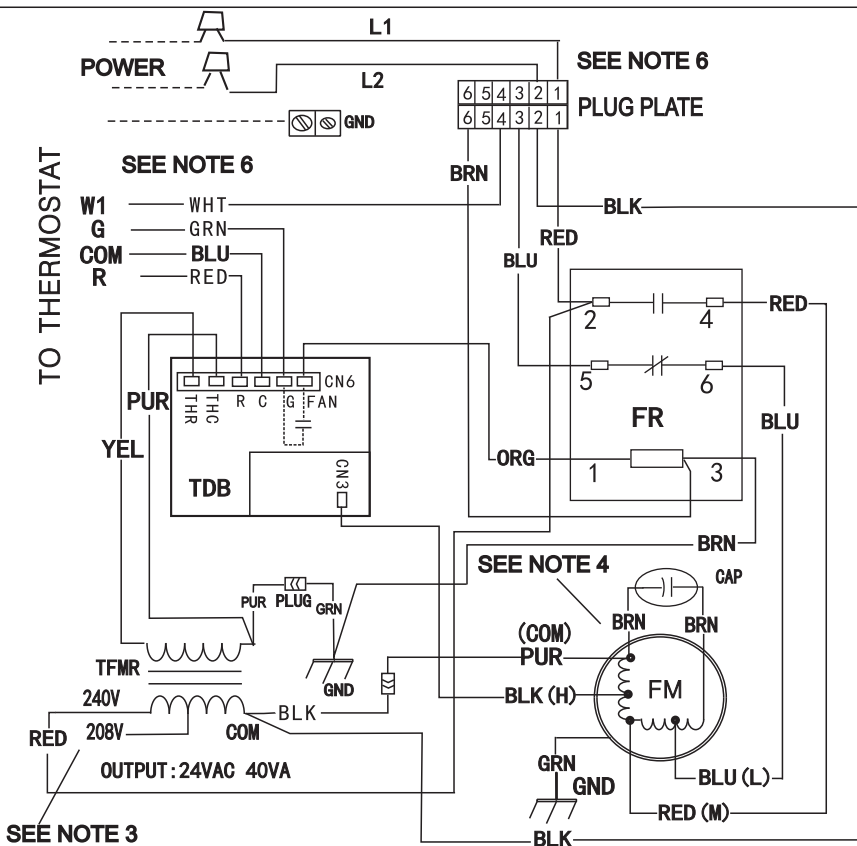

COMPONENT ARRANGEMENT

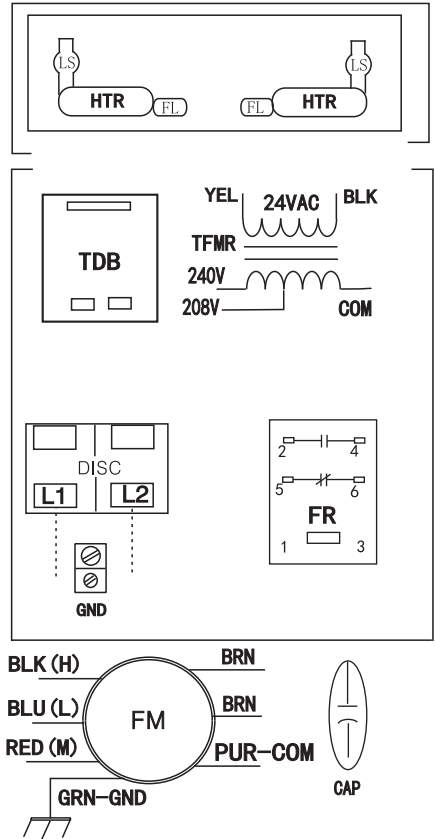

LEGEND:

- FR FAN RELAY
- TDB TIME DELAY BOARD
- TFMR TRANSFORMER
- FM FAN MOTOR
- CAP FAN CAPACITOR
- GND GROUND
- - - FIELD POWER WIRING
- FACTORY POWER WIRING

NOTES:

- 1: Use copper wire(105°C min), to be wired in accordance with N.E.C. and local codes.
- 2: If any of the original wire as supplied must be replaced,use the same or equivalent type wire.
- 3: Remove the red lead from "240V" terminal and then connect the red lead to "208V" terminal on the transformer for 208 volts.
- 4: Factory default fan speed is medium; FM red wire connected to FR #4. For HI speed connect FM black wire to FR #4. For LOW speed connect FM blue wire to FR #4 and FM red wire to FR #6. Always connect the unused FM wire to the dummy terminal CN3.
- 5: TDB has a 90-100s off delay when "G" is de-energized.
- 6: Connect R to R, G to G, etc. See outdoor or indoor instructions for details.
- 7: Cooling controls wiring not used with electric heaters,connect the plug to electric heaters kit when applied.
- 8: N.E.C., class2,24volts.

Fig. 4-1

Section 5. - Heater Pressure Drop Table - Use For All TMM4A Wall Mount Air Handler Models

MODEL	AIRFLOW CFM	NUMBER OF RACKS		
		1	2	3
		AIR PRESSURE DROP - INCHES W.G.		
TMM4A0B30, 36	1400	0.06	0.08	0.08
	1300	0.06	0.08	0.08
	1200	0.06	0.08	0.08
	1100	0.06	0.08	0.08
	1000	0.06	0.08	0.08
	900	0.04	0.06	0.06
	800	0.04	0.06	0.06
	700	0.04	0.06	0.06
TMM4A0A18, 24	900	0.04	0.06	0.06
	800	0.04	0.06	0.06
	700	0.04	0.06	0.06
	600	0.04	0.06	0.06
	500	0.04	0.06	0.06

HEATER RACKS	
HEATER MODEL	NO. OF RACKS
BAYHTRM505BRKAA	1
BAYHTRM508BRKAA	2
BAYHTRM510BRKAA	3

Accessory Heater Usage

NUMBER OF RACKS	SIZES USED WITH	kW	INTERNAL CIRCUIT PROTECTION
1	18-36	5	Circuit Breaker
2	18-36	7.5	Circuit Breaker
3	18-36	10	Circuit Breaker

Minimum CFM

MODEL	NUMBER OF RACKS		
	1	2	3
TMM4A0A18M21SAA	450	500	600
TMM4A0A24M21SAA	450	500	600
TMM4A0B30M21SAA	700	725	750
TMM4A0B36M31SAA	700	725	750

Section 6. Performance and Electrical Data

Airflow performance data is based on cooling performance with a coil and no filter in place. Select performance table for appropriate unit size external static applied to unit allows operation within the minimum and maximum limits shown in table below for both cooling and electric heat operation.

Model Number	Motor Speed		CFM(Watts)									
			External Static Pressure-Inches W.C.[kPa]									
			0[0]	0.1[.02]	0.16[.04]	0.2[.05]	0.3[.07]	0.4[.10]	0.5[.12]	0.6[.15]	0.7[.17]	0.8[.20]
18	Low	CFM	590	556	526	520	481	437	387	-	-	-
		RPM	598	645	686	696	745	790	836	-	-	-
		Watts	168	165	161	161	156	150	145	-	-	-
		Amps	0.75	0.73	0.72	0.72	0.7	0.68	0.66	-	-	-
	Middle	CFM	686	650	621	615	578	536	486	-	-	-
		RPM	685	719	749	759	799	837	873	-	-	-
		Watts	184	178	174	174	170	164	158	-	-	-
		Amps	0.81	0.78	0.77	0.77	0.75	0.73	0.71	-	-	-
	High	CFM	796	760	733	725	685	644	596	541	477	400
		RPM	778	805	827	836	867	906	929	956	984	1011
		Watts	236	232	227	227	220	213	205	196	188	179
		Amps	1.04	1.02	1.01	1.0	0.98	0.95	0.92	0.89	0.86	0.83
24	Low	CFM	696	662	632	624	583	537	485	-	-	-
		RPM	700	741	767	774	808	843	882	-	-	-
		Watts	198	193	190	188	183	178	170	-	-	-
		Amps	0.89	0.88	0.86	0.86	0.84	0.82	0.8	-	-	-
	Middle	CFM	850	814	775	766	720	672	617	-	-	-
		RPM	837	861	878	885	903	923	945	-	-	-
		Watts	236	231	227	226	221	217	211	-	-	-
		Amps	1.03	1.01	1.0	0.99	0.98	0.96	0.94	-	-	-
	High	CFM	938	894	860	859	813	764	710	674	573	465
		RPM	921	937	950	953	967	980	994	1010	969	1051
		Watts	300	295	289	283	283	277	271	263	254	242
		Amps	1.33	1.31	1.29	1.26	1.26	1.24	1.22	1.19	1.16	1.12

Model Number	Motor Speed		CFM(Watts)									
			External Static Pressure-Inches W.C.[kPa]									
			0[0]	0.1[.02]	0.2[.05]	0.24[.06]	0.3[.07]	0.4[.10]	0.5[.12]	0.6[.15]	0.7[.17]	0.8[.20]
30	Low	CFM	997	948	903	891	861	809	760	-	-	-
		RPM	755	789	817	828	846	870	903	-	-	-
		Watts	305	295	287	283	278	271	263	-	-	-
		Amps	1.53	1.51	1.49	1.48	1.47	1.46	1.44	-	-	-
	Middle	CFM	1187	1125	1076	1055	1021	974	912	-	-	-
		RPM	875	899	916	924	935	952	967	-	-	-
		Watts	339	331	324	321	317	309	302	-	-	-
		Amps	1.67	1.66	1.64	1.63	1.62	1.61	1.59	-	-	-
	High	CFM	1306	1249	1195	1166	1132	1069	1008	937	860	759
		RPM	956	968	982	987	994	1007	1015	1027	1041	1054
		Watts	427	417	409	406	400	391	384	375	363	351
		Amps	2.20	2.18	2.16	2.15	2.15	2.13	2.11	2.09	2.07	2.05
36	Low	CFM	1106	1056	1007	990	960	918	857	-	-	-
		RPM	818	843	868	878	893	916	941	-	-	-
		Watts	371	361	349	346	338	328	316	-	-	-
		Amps	1.62	1.58	1.53	1.52	1.49	1.44	1.4	-	-	-
	Middle	CFM	1269	1213	1153	1131	1097	1069	973	-	-	-
		RPM	920	933	947	956	965	982	997	-	-	-
		Watts	410	401	391	385	380	368	357	-	-	-
		Amps	1.79	1.74	1.70	1.67	1.65	1.60	1.55	-	-	-
	High	CFM	1375	1320	1267	1248	1204	1142	1082	1011	919	801
		RPM	986	996	1007	1011	1018	1030	1040	1051	1063	1079
		Watts	461	450	440	436	427	416	402	388	376	358
		Amps	2.01	1.96	1.92	1.90	1.87	1.81	1.76	1.70	1.65	1.57

■ – Shaded boxes represent airflow outside the required 300-450 cfm/ton.

NOTES:

1. Airflow based upon dry coil at 230V with no electric heat, no filter.
2. Airflow is equivalent for front or bottom return configurations.
3. SCFM is nearly the same with cooling performance airflow, the gap is in the 1 to 2%.

The air distribution system has the greatest effect on airflow. The duct system is totally controlled by the contractor. For this reason, the contractor should use only industry-recognized procedures.

Duct design and construction should be carefully done. System performance can be lowered dramatically through bad planning or workmanship. Air supply diffusers must be selected and located carefully. They must be sized and positioned to deliver air along the perimeter of the space. If they are too small for their intended airflow, they become noisy. If they are not located properly, they cause drafts. Air grilles must be properly sized to carry air back to the blower. If they are too small, they also cause noise.

The installers should balance the air distribution system to ensure proper quiet airflow to all rooms in the home. This ensures a comfortable living space.

Section 7. Dimensional Data

6.1 UNIT DIMENSIONS

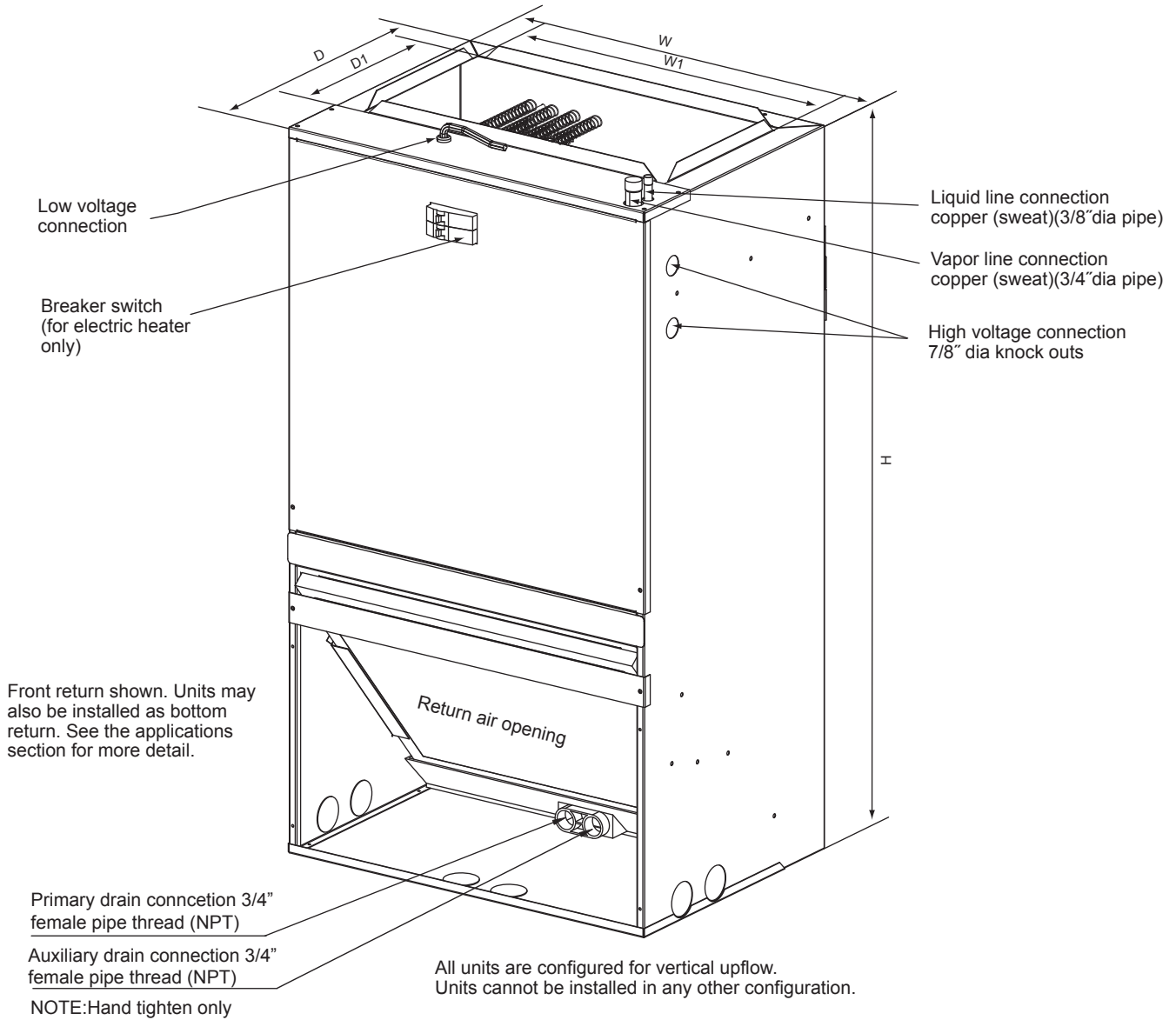

Fig. 6-1 DIMENSIONS

DIMENSIONAL DATA

MODEL SIZE	Dimensions inch [mm]					UNIT WEIGHT /SHIPPING WEIGHT (LBS.[kg])
	UNIT HEIGHT "H" IN. [mm]	UNIT WIDTH "W" IN.[mm]	UNIT WIDTH "W1" IN.[mm]	UNIT LENGHT "D" IN.[mm]	UNIT LENGHT "D1" IN.[mm]	
18	36-1/2"[928]	20-1/2"[522]	16--5/8"[422]	15"[381]	9-1/2"[242]	88/99 [40]/[45]
24	36-1/2"[928]	20-1/2"[522]	16--5/8"[422]	15"[381]	9-1/2"[242]	88/99 [40]/[45]
30	39-1/2"[1004]	22"[559]	18--3/4"[477]	19"[483]	9-1/2"[242]	110/121 [50]/[55]
36	39-1/2"[1004]	22"[559]	18--3/4"[477]	19"[483]	9-1/2"[242]	110/121 [50]/[55]



6200 Troup Highway
Tyler, TX 75707
www.trane.com
www.americanstandardair.com

The manufacturer has a policy of continuous product and product data improvement and reserves the right to change design and specifications without notice.
© Trane U.S. Inc. 2013