

Submittal

4 Ton Convertible Air Handler TEM4A0C48S41SB

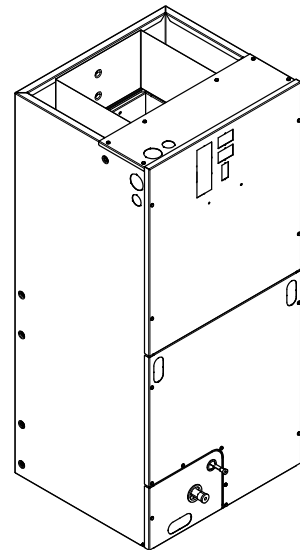

TAG: _____

▲ SAFETY WARNING

Only qualified personnel should install and service the equipment. The installation, starting up, and servicing of heating, ventilating, and air-conditioning equipment can be hazardous and requires specific knowledge and training. Improperly installed, adjusted or altered equipment by an unqualified person could result in death or serious injury. When working on the equipment, observe all precautions in the literature and on the tags, stickers, and labels that are attached to the equipment.

Outline Drawing

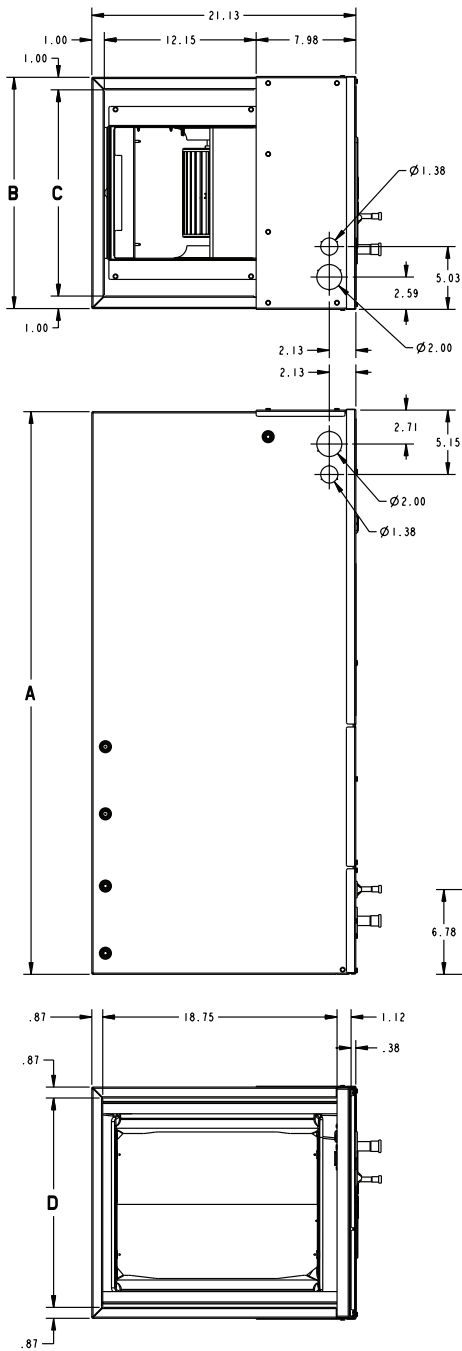

MINIMUM UNIT CLEARANCE TABLE	
	SERVICE CLEARANCE (RECOMMENDED)
SIDES	2"
FRONT	21"
BACK	0"
INLET DUCT	1"
OUTLET DUCT	N/A

NOTE: THIS UNIT IS APPROVED FOR INSTALLATION CLEARANCES TO COMBUSTIBLE MATERIAL AS STATED ON THE UNIT RATING NAMEPLATE

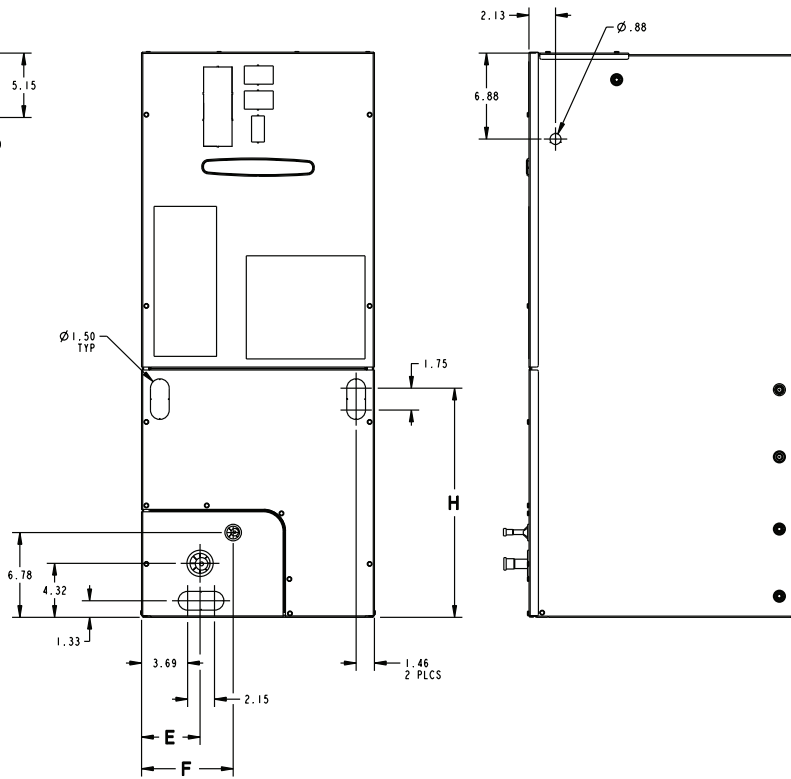

PRODUCT DIMENSIONS									
Air Handler Model	A	B	C	D	E	F	H	Flow Control	Gas Line Braze
TEM4A0C48S41SB	51.27	23.50	21.50	21.75	7.01	9.66	24.59	TXV	7/8

All dimensions are in inches

Product Specifications

MODEL	TEM4A0C48S41SB
RATED VOLTS/PH/HZ	208-230/1/60
RATINGS^(a)	See O.D. Specifications
INDOOR COIL — Type	Plate Fin
Rows — F.P.I.	3 - 14
Face Area (sq. ft.)	5.50
Tube Size (in.)	3/8
Refrigerant Control	TXV
Drain Conn. Size (in.) ^(b)	3/4 NPT
DUCT CONNECTIONS	See Outline Drawing
INDOOR FAN — Type	Centrifugal
Diameter-Width (In.)	11 X 8
No. Used	1
Drive - No. Speeds	Direct - 3 ^(c)
CFM vs. in. w.g.	See Fan Performance Table
No. Motors — H.P.	1 - 3/4
Motor Speed R.P.M.	1050
Volts/Ph/Hz	208-230/1/60
F.L. Amps	6.0
FILTER	
Filter Furnished? ^(d)	No
REFRIGERANT	R-410A
Ref. Line Connections	Brazed
Coupling or Conn. Size — in. Gas	7/8

Coupling or Conn. Size — in. Liq.	3/8
DIMENSIONS	H x W x D
Crated (In.)	52-1/2 x 26 x 24
Uncrated	51-3/8 x 23-1/2 x 21-1/8
WEIGHT	
Shipping (Lbs.) / Net (Lbs.)	145/138

- ^(a) These Air Handlers are A.H.R.I certified with various Split System Air Conditioners and Heat Pumps (AHRI STANDARD 210/240). Refer to the Split System Outdoor Unit Product Data Guides for performance data.
- ^(b) 3/4" Male Plastic Pipe (Ref: ASTM 1785-76)
- ^(c) ECM Motor
- ^(d) Remote filter required.

Minimum Airflow CFM

TEM4A0C48S41SB		
Heater	Minimum Heat Speed Tap	
	With Heat Pump	Without Heat Pump
BAYHTR1504BRK, BAYHTR1504LUG, BAYHTR1505BRK, BAYHTR1505LUG	Low	Low
BAYHTR1508BRK, BAYHTR1508LUG, BAYHTR1510BRK, BAYHTR1510LUG, BAYHTR3510LUG	Low	Low
BAYHTR1517BRK	Low	Low
BAYHTR1523BRK	Low	Low
BAYHTR1525BRK	Low	Low
BAYHTR3517LUG	Low	Low

Heater Pressure Drop Table

TEM Air Handler Models

Airflow CFM	Number of Racks				Heater Racks	
	1	2	3	4	Heater Model	No. of Racks
	Air Pressure Drop — Inches W.G.					
1800	0.02	0.04	0.06	0.14	BAYHTR1504	1
1700	0.02	0.04	0.06	0.14	BAYHTR1505	1
1600	0.02	0.04	0.06	0.13	BAYHTR1508	2
1500	0.02	0.04	0.06	0.12	BAYHTR1510	2
1400	0.02	0.04	0.06	0.12	BAYHTR3510	3
1300	0.02	0.04	0.05	0.11	BAYHTR1515	3
1200	0.01	0.04	0.05	0.10	BAYHTR1517	3
1100	0.01	0.03	0.05	0.09	BAYHTR3515	3
1000	0.01	0.03	0.04	0.09	BAYHTR3517	3
900	0.01	0.03	0.04	0.08	BAYHTR1519	4
800	0.01	0.03			BAYHTR1520	4
700	0.01	0.02			BAYHTR1521	4
600	0.01	0.02			BAYHTR1523	4
					BAYHTR1525	4

Performance and Electrical Data

1. See Product Data or Air Handler nameplate for approved combinations of Air Handlers and Heaters.
2. Heater model numbers may have additional suffix digits.

Table 1. Air Flow Performance

TEM4A0C48S41SB (a)			
EXTERNAL STATIC (in w.g)	AIRFLOW		
	Speed Taps — 230 VOLTS		
	High	Med	Low †
0.1	1784	1698	1634
0.2	1748	1662	1595
0.3	1715	1627	1559
0.4	1682	1591	1521
0.5	1650	1558	1488
0.6	1618	1525	1455
0.7	1499	1494	1422

1. Values are with wet coil, no filter, and no heaters
 2. CFM Correction for dry coil = Add 3%
 3. † = Factory setting
 4. Low = Taps 1-3, Med = Tap 4, High = Tap 5

(a) For TEM4A0C48S41SB in downflow applications, airflow must not exceed 1600 cfm due to condensate blow off.

Performance and Electrical Data

Table 2. Electrical Data

TEM4A0C48S41SB											
Heater Model No.	No. of Circuits/ Phases	240 Volt					208 Volt				
		Capacity		Heater Amps per Circuit	Minimum Circuit Ampacity	Maximum Overload Protection	Capacity		Heater Amps per Circuit	Minimum Circuit Ampacity	Maximum Overload Protection
		kW	BTUH				kW	BTUH			
No Heater				6.0 *	8	15			6.0 *	8	15
BAYHTR1504BRK BAYHTR1504LUG	1/1	3.84	13100	16.0	28	30	2.8- 8	9800	13.8	25	25
BAYHTR1505BRK BAYHTR1505LUG	1/1	4.8	16400	20.0	33	35	3.6	12300	17.3	29	30
BAYHTR1508BRK BAYHTR1508LUG	1/1	7.68	26200	32.0	48	50	5.7- 6	19700	27.7	42	45
BAYHTR1510BRK BAYHTR1510LUG	1/1	9.6	32800	40.0	58	60	7.2	24600	34.6	51	60
BAYHTR1517BRK- Circuit 1 ^(a)	2/1	9.6	32800	40.0	58	60	7.2	24600	34.6	51	60
BAYHTR1517BRK- Circuit 2		4.8	16400	20.0	25	25	3.6	12300	17.3	22	25
BAYHTR1523BRK- Circuit 1	2/1	9.6	32800	40.0	58	60	7.2	24600	34.6	51	60
BAYHTR1523BRK- Circuit 2		9.6	32800	40.0	50	50	7.2	24600	34.6	43	45
BAYHTR1525BRK- Circuit 1	4/1	6.0	20500	25.0	39	40	4.5	15400	21.6	35	35
BAYHTR1525BRK- Circuit 2		6.0	20500	25.0	31	35	4.5	15400	21.6	27	30
BAYHTR1525BRK- Circuit 3		6.0	20500	25.0	31	35	4.5	15400	21.6	27	30
BAYHTR1525BRK- Circuit 4		6.0	20500	25.0	31	35	4.5	15400	21.6	27	30
BAYHTR3510LUG	1/3	9.6	32800	23.1	36	40	7.2	24600	20.0	32	35
BAYHTR3517LUG	1/3	14.4	49100	34.6	50	50	10.- 8	36900	30.0	44	45

* = Motor Amps

^(a) MCA and MOP for circuit 1 contains the motor amps.

Features and Benefits

- Painted metal cabinet with captured foil face insulation
- 2% or less air leakage
- R-4.2 Insulating Value
- Multi-Position UP/Down Flow, Horizontal Left /Right
- ALL Aluminum Coil with Enhanced Patented Coil Fin
- Electric Heaters with polarized plug connections (sold as accessory)
- R-410A Thermal Expansion Valve
- ECM Motor (**3.5 – 5 Ton Models**)

- Low Voltage Pigtail Connections
- Draw Through Design
- Horizontal Drain pan
- Fused 24V Power
- **3 year warranty**
- **10-year warranty registered**
- **Optional extended warranty available**

Important: Condensate management kit is required for all 5 ton air handler models installed in downflow applications.



Ingersoll Rand (NYSE: IR) advances the quality of life by creating comfortable, sustainable and efficient environments. Our people and our family of brands — including Club Car®, Ingersoll Rand®, Thermo King® and Trane® — work together to enhance the quality and comfort of air in homes and buildings; transport and protect food and perishables; and increase industrial productivity and efficiency. We are a global business committed to a world of sustainable progress and enduring results.



ingersollrand.com



Ingersoll Rand has a policy of continuous product and product data improvements and reserves the right to change design and specifications without notice.
We are committed to using environmentally conscious print practices.