

Installer's Guide

Wall Mount Air Handlers 2 – 3 Ton

AC models

GMU2APB24051SA
GMU2APB24081SA
GMU2APB30081SA
GMU2AEB37101SA

HP models

GMV2APB26051SA
GMV2APB26081SA
GMV2APB32081SA
GMV2AEB39101SA

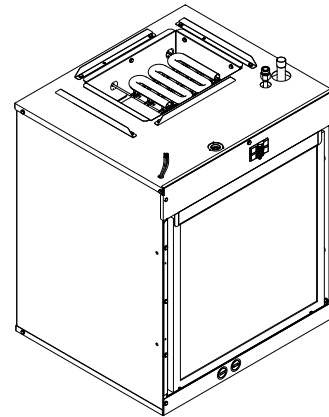

The GMU and GMV series air handlers are designed for wall mount or flush mount installations in a closet, utility room, alcove, or basement. These versatile units are applicable to air conditioning and heat pump applications. Several models are available to meet the specific requirements of the outdoor equipment. Electric resistance heaters are factory installed.

▲ SAFETY WARNING

Only qualified personnel should install and service the equipment. The installation, starting up, and servicing of heating, ventilating, and air-conditioning equipment can be hazardous and requires specific knowledge and training. Improperly installed, adjusted or altered equipment by an unqualified person could result in death or serious injury. When working on the equipment, observe all precautions in the literature and on the tags, stickers, and labels that are attached to the equipment.

SAFETY SECTION

AIR HANDLERS

Important: This document contains a wiring diagram and service information. This is customer property and is to remain with this unit. Please return to service information pack upon completion of work.

Important: These instructions do not cover all variations in systems nor provide for every possible contingency to be met in connection with the installation. Should further information be desired or should particular problems arise which are not covered sufficiently for the purchaser's purposes, the matter should be referred to your installing dealer or local distributor.

⚠ WARNING

HAZARDOUS VOLTAGE!

Failure to follow this Warning could result in property damage, severe personal injury, or death.

Disconnect all electric power, including remote disconnects before servicing. Follow proper lockout/tagout procedures to ensure the power cannot be inadvertently energized.

⚠ CAUTION

GROUNDING REQUIRED!

Failure to inspect or use proper service tools may result in equipment damage or personal injury.

Reconnect all grounding devices. All parts of this product that are capable of conducting electrical current are grounded. If grounding wires, screws, straps, clips, nuts, or washers used to complete a path to ground are removed for service, they must be returned to their original position and properly fastened.

⚠ WARNING

LIVE ELECTRICAL COMPONENTS!

Failure to follow this Warning could result in property damage, severe personal injury, or death.

Follow all electrical safety precautions when exposed to live electrical components. It may be necessary to work with live electrical components during installation, testing, servicing, and troubleshooting of this product.

⚠ WARNING

PRESSURIZED REFRIGERANT!

Failure to follow this Warning could result in personal injury

System contains oil and refrigerant under high pressure. Recover refrigerant to relieve pressure before opening the system. Do not use non-approved refrigerants or refrigerant substitutes or refrigerant additives.

⚠ CAUTION

SHARP EDGE HAZARD!

Failure to follow this Caution could result in property damage or personal injury.

Be careful of sharp edges on equipment or any cuts made on sheet metal while installing or servicing.

⚠ CAUTION

HAZARDOUS VAPORS!

Failure to follow this caution could result in property damage or personal injury.

Equipment corrosion damage. To prevent shortening its service life, the air handler should not be used during the finishing phases of construction or remodeling. The low return air temperatures can lead to the formation of condensate. Condensate in the presence of chlorides and fluorides from paint, varnish, stains, adhesives, cleaning compounds, and cement creates a corrosive condition which may cause rapid deterioration of the cabinet and internal components.

⚠ CAUTION

COIL IS PRESSURIZED!

- Coil is pressurized with approximately 8–12 psi dry air and factory checked for leaks.
- Carefully release the pressure by removing the rubber plug on the liquid line.
- If no pressure is released, check for leaks.

⚠ WARNING

WARNING!

This product can expose you to chemicals including lead, which are known to the State of California to cause cancer and birth defects or other reproductive harm.

For more information go to www.P65Warnings.ca.gov.

⚠ WARNING

SAFETY HAZARD!

This appliance is not to be used by persons (including children) with reduced physical, sensory, or mental capabilities, or lack of experience and knowledge, unless they have been given supervision or instruction.

⚠ WARNING

SAFETY HAZARD!

Children should be supervised to ensure that they do not play with the appliance.

⚠ WARNING

This product can expose you to chemicals including lead, which are known to the State of California to cause cancer and birth defects or other reproductive harm. For more information go to www.P65Warnings.ca.gov!

Important: Installation of this unit shall be made in accordance with the National Electric Code, NFPA No. 90A and 90B, and any other local codes or utilities requirements.

Note: The manufacturer recommends installing ONLY A.H.R.I approved, matched indoor and outdoor systems. Some of the benefits of installing approved matched indoor and outdoor split systems are maximum efficiency, optimum performance, and the best overall system reliability.

Table of Contents

Installation	5	Fixed Orifice Superheat Charging	
Features	5	Table	16
Installation Instructions	5	Outline Drawing	17
Field Wiring	9	Blower Serviceability	18
Electrical Data	10	Checkout Procedures	19
Performance and Electrical Data	13		

Installation

Features

Table 1. Standard Features

<ul style="list-style-type: none"> • GALVANIZED STEEL EXTERIOR • STURDY POLYCARBONATE DRAIN PAN • 208/230 VAC OPERATION • ECM MULTI-SPEED DIRECT DRIVE CTM BLOWER (GMU2AEB37101SA and GMV2AEB39101SA only) • MULTI-SPEED DIRECT DRIVE PSC BLOWER • FACTORY SUPPLIED R-410A THERMAL EXPANSION VALVE ON GMV MODELS • ALL ALUMINUM COIL • MEETS THE MINIMUM LEAKAGE REQUIREMENTS FOR THE FLORIDA AND CALIFORNIA BUILDING CODES • FRONT RETURN • Factory installed 5, 8, and 10 KW SINGLE PHASE ELECTRIC HEATERS <ul style="list-style-type: none"> – Circuit breakers on all heaters • SUPPLY DUCT FLANGES
--

Table 2. Optional Accessories

<p>Use with all GMU2 and GMV2 models</p> <ul style="list-style-type: none"> • BAYTGM1WALLPNL — Wall Mount Panel Quantity 1 • BAYTGM5WALLPNL — Wall Mount Panel Quantity 5 <p>Use with GMU2APB24051SA, GMU2APB24081SA, GMV2APB26051SA, GMV2APB26081SA models</p> <ul style="list-style-type: none"> • BAYFRT5LVPNL26A — Louver Panel Quantity 5 • BAYFRT1LVPNL26A — Louver Panel Quantity 1 <p>Use with GMU2APB30081SA, GMU2AEB37101SA, GMV2APB32081SA, GMV2AEB39101SA models</p> <ul style="list-style-type: none"> • BAYFRT5LVPNL30A — Louver Panel Quantity 5 • BAYFRT1LVPNL30A — Louver Panel Quantity 1

Table 3. Optional Orifice Kits

Outdoor Unit Capacity (Tons)	Orifice Size (R410A or R22)	Orifice Kit Number
1.5	0.049	BAYORIACH-P0049A
2.0	0.057	BAYORIACH-P0057A
2.5	0.061	BAYORIACH-P0061A
3.0	0.067	BAYORIACH-P0067A

Installation Instructions

1. Unpacking

Carefully unpack the unit and inspect the contents for damage. If any damage is found at the time of delivery, proper notification and claims should be made with the carrier.

Check the rating plate to assure model number and voltage, plus any kits match with what you ordered. The manufacturer should be notified within 5 days of any discrepancy or parts shortage.

2. General Applications

The GMV modelst can be used in an R22 application by replacing the TXV with the correct size fixed orifice piston.

The GMU models can be applied in either 410A or R22 applications when the correct fixed orifice piston is installed

3. Location

The air handler should be centrally located and can be installed in a wall, closet, alcove, utility room, or basement. Minimum clearances should be met. When the unit is installed in a closet or utility room, the room should be large enough, and have an opening to allow replacement of the unit. All servicing is done from the front and a clearance of 21" is needed for service unless the closet door or wall panel aligns with the front of the air handler.

The air handler comes standard with two different mounting options - wall mount or flush mount. Both mounting options require that the unit be installed level from side to side. Up to a 1/4" slope towards the front is allowed. Both mounting options also require that the mounting structure have the ability to support a minimum load of 150lbs. Failure to do this will cause damage to the support structure and potentially damage the unit.

Wall Mount Installation

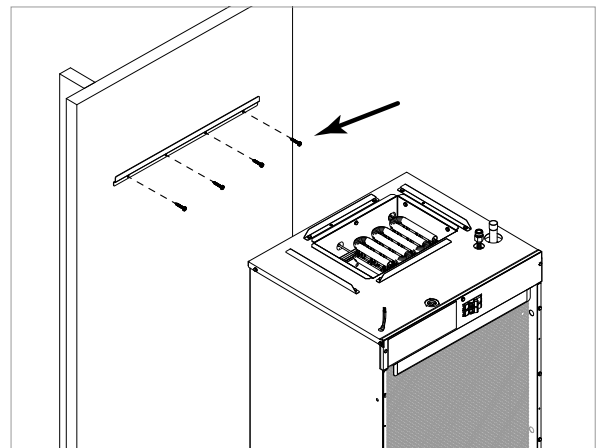

The air handler comes with a wall mounting bracket for hanging the unit on a wall.

Note: Ensure bracket is installed on a structure that can support a minimum load of 150 lbs. If structure cannot support 150 lbs, additional support may be needed.

1. Align holes of the bracket with wall studs or wall

Installation

structure. Ensure bracket is level. Install bracket on the wall using the 4 provided wood screws.

2. Lift unit and slide the back edge of top cap onto bracket.

Flush Mount Installation

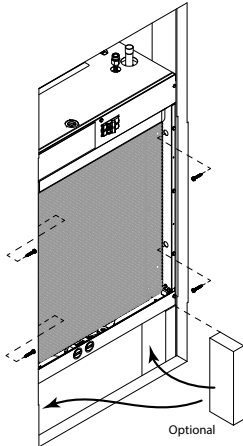

Important: The unit should be installed flush with the studs, not the sheetrock. This allows clearance between the louvered panel and the unit so the filter will not be pressed up against the grill. It also prevents the breaker switch from hitting the panel.

The air handler comes with 4 clearance holes (2 on each side) for mounting the unit flush between wall studs or in a frame structure. NOTE: Ensure unit is installed in a structure that can support a minimum load of 150 lbs. Additional supports can be attached to the studs to support the unit during installation. See Figure.

Note: For ease of installation, optional two by fours can be secured to the studs to support the weight of the unit during installation.

1. Install the 4 provided wood screws into the frame from within the air handler through the 2 clearance holes on each side of the unit. Installing the screws from outside the unit could cause damage to the coil.
 2. Make sure unit is level and secure before proceeding.
 3. If using optional louvered panel which must be ordered separately, install the louvered panel per panel kit installation instructions.
4. **Duct Work**

The duct work should be installed in accordance with the NFPA No. 90A "Installation of Air Conditioning and Ventilating systems" and No. 90B "Residential Type Warm Air Heating and Air Conditioning Installation."

The duct work should be insulated in accordance with the applicable requirements for the particular

installation as required by HUD, FHA, VA the applicable building code, local utility or other governing body.

5. Fresh Air

Note: This unit does not come with direct coupling for fresh air.

Note: Do not tie into the air handler cabinet for fresh air.

6. Condensate Drain

This unit has 2 condensate drain options; front or bottom. The unit comes from the factory ready for front condensate connection. For bottom condensate, remove the plugs from the bottom drain connections and install them in the front drain connections.

Note: Ensure that the unused location has the plugs in place and are checked for leaks.

Each condensate drain option is supplied with primary and auxiliary 3/4" NPT connections. The primary drain must be trapped outside the unit and piped in accordance with applicable building codes.

The figure shows the operation of a properly designed trap under normal operating conditions.

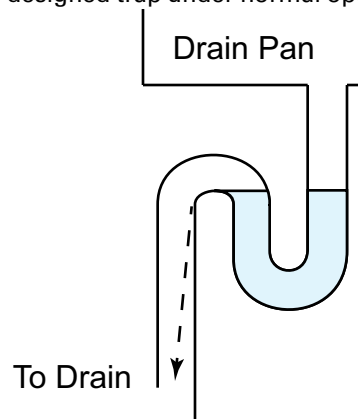

Proper operation of condensate trap under normal operating conditions.

Do not reduce the drain line size less than the connection size on the drain pan. Condensate should be piped to an open drain or to the outside. All drains must pitch downward away from the unit a minimum of 1/4" per foot of line to ensure proper drainage.

Important: If cleanout Tee is used, stand pipe must be sealed/capped.

Important: If a vent Tee is used, it must be downstream from the trap.

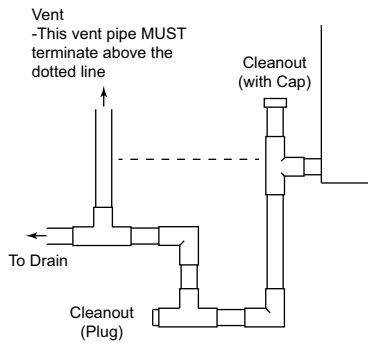

Insulate the primary drain line to prevent sweating where dew point temperatures may be met. (Insulation is optional depending on climate and application needs.)

7. Refrigerant Piping

Refrigerant piping external to the unit shall be sized in accordance with the instructions of the manufacturer of the outdoor equipment.

8. Metering Device

GMV2 units are supplied with an internally-checked, non-bleed TXV designed for air conditioning or heat pump operation. Some outdoor models may require a start assist kit.

GMU2 models include a factory installed orifice piston. Piston size may need to be changed depending on the equipment match. See outdoor unit for more information.

Table 4. Included Metering Device

Air Handler Model	Flow Control
GMU2APB24051SA, GMU2APB24081SA	Orifice
GMU2APB30081SA, GMUSAEB37101SA	Orifice
GMV2APB26051SA, GMV2APB26081SA	TXV
GMV2APB32081SA, GMV2AEB39101SA	TXV

TXV Installation for Heat Pump models

Note: Factory supplied O-rings must be used between TXV fitting connections.

Note: Make sure to use a back-up wrench when loosening or tightening fittings.

Note: This unit can be used in an R22 application by replacing the TXV with the correct size fixed orifice piston. See [Table 5, p. 8](#) for proper piston size.

GMV2 heat pump models require the supplied TXV to be field installed. First, remove the stub tube from the air handler liquid line. Braze the stub tube to the field liquid line. Install the TXV and O-ring to the liquid line fitting on the exterior of the cabinet. Attach the inlet stub tube and O-ring to the TXV. Attach the TXV sensing bulb to the field installed vapor line outside of the unit using the supplied clip

to secure in place. Once installed, wrap the bulb and clip with supplied insulation. Remove the breaker panel to access the vapor line pressure port. Route the TXV equalizer line with the 1/4" flare nut down into the cabinet through the vapor line cutout and connect to the pressure port on the vapor line. The excess equalizer line must remain outside of the cabinet.

Note: Ensure the valve core is removed for TXV operation.

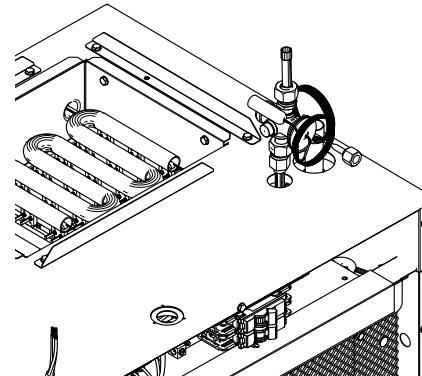

Orifice piston change on AC models

Some GMU2 AC models require the orifice piston to be replaced with a different size, which can be purchased as individual kits from our parts department (See [Table 4](#)). The orifice piston is accessed by removing the front breaker panel. Use a back-up wrench when disconnecting the fitting. Remove the old piston using the wire tool supplied with the kit. Install the new piston and tighten fitting. Make sure to use a back-up wrench when tightening fitting.

Note: The cabinet cover has been removed in the illustration to show the interior component detail. It should not be removed when replacing the orifice piston.

Note: The wire tool pictured ships with the orifice piston replacement kits.

Note: This unit can be applied in both 410A and R22 applications when the correct fixed orifice piston is installed. See [Table 5, p. 8](#).

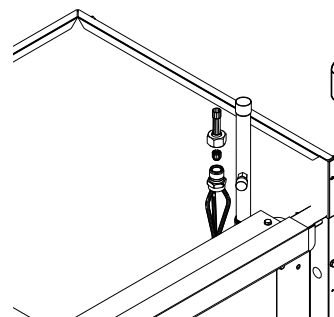

Table 5. Orifice Piston Size Table

Orifice Piston Size Table		
Outdoor Unit Capacity (Tons)	Indoor Unit Fixed Orifice Piston Size ^(a)	Indoor Unit Fixed Orifice Replacement Part Kit Number
1.5	0.049	BAYORIACHP0049A
2.0	0.057 ^(b)	BAYORIACHP0057A
2.5	0.061 ^(b)	BAYORIACHP0061A
3.0	0.067 ^(b)	BAYORIACHP0067A

^(a) Sizes are for both R-410A and R-22 refrigerants.

^(b) Factory installed in corresponding indoor units.

9. Blower

This unit is supplied with a multi-speed motor with a direct drive blower wheel which can obtain various air flows. The unit is shipped with factory set cooling and heating speed taps. Airflow performance tables are available for additional speed taps. Disconnect all power to the unit before making any adjustments to the motor speed taps. Be sure to check the temperature drop across the evaporator coil to ensure sufficient air flow.

10. Circuit Breaker

Be sure to remove the tie wrap used to secure circuit breaker during shipping. Ensure the circuit breaker is correctly installed onto the circuit breaker bracket.

11. Wiring

Consult all schematic and pictorial wiring diagrams of this unit and the outdoor equipment to determine compatibility of wiring connections and to determine specific requirements.

All field wiring to the air handler should be installed in accordance with the latest edition of the National Electric Code NFPA No. 70 and any local codes. Check rating plates on unit for rated volts, minimum circuit ampacity and maximum over current protection. Supply circuit power wiring must be 75 degree C (167 degree F) minimum copper conductors only. Copper supply wires shall be sized to the National Electric Code or local code requirements, whichever is more stringent.

The unit is shipped wired for 230/240 Volt AC 60 HZ 1 Phase Operation. If the unit is to be operated at 208 VAC 60HZ, follow the instructions on the indoor unit wiring diagram to change the low voltage transformer to 208 VAC operation (Ensure unit is properly grounded).

Class 2 low voltage control wiring should not be run in conduit with line voltage and must be separated from line voltage unless class 1 wire with proper voltage rating is used.

Low voltage control wiring should be 18 Awg, color coded (105 degree C minimum). For lengths longer

than 100ft., 16 Awg wire should be used. Make certain that separation of control wiring and line voltage has been maintained.

12. Thermostat

Select a thermostat that is commonly used with HP or AC single stage heating/cooling with electric heat. The thermostat will energize the fan on a demand for heat or cool.

Install the thermostat on an inside wall, away from drafts, lights or other heat sources in a location that has sufficient air circulation from other rooms being controlled by the thermostat.

13. Sequence of Operation Cooling (Cooling only)

PSC versions - When the thermostat calls for cooling, the circuit from R to G is completed. The blower relay is energized.

Constant torque version – When the thermostat calls for cooling, the circuit from R to G is completed. The blower motor is energized directly by the 24VAC signal from the thermostat.

The circuit from R to Y is also complete energizing the compressor contactor of the outdoor unit. The contactor will close and start the compressor and condenser fan motor.

Cooling (heat pump)

PSC versions - When the thermostat calls for cooling, the circuit from R to G is completed. The blower relay is energized.

Constant torque version – When the thermostat calls for cooling, the circuit from R to G is completed. The blower motor is energized directly by the 24VAC signal from the thermostat.

The circuit from R to Y is also complete energizing the compressor contactor of the outdoor unit. The contactor will close and start the compressor and condenser fan motor.

Circuit R to O energizes the reversing valve to the cooling position.

Heating (heat pump)

PSC versions - When the thermostat calls for heating, the circuit from R to G is completed. The blower relay is energized.

Constant torque version – When the thermostat calls for heating, the circuit from R to G is completed and the blower motor is energized directly by the 24VAC signal from the thermostat.

The circuit from R to Y is also complete energizing the compressor contactor of the outdoor unit. The contactor will close and start the compressor and condenser fan motor.

In the heating mode, the reversing valve of the outdoor unit is not energized.

If the indoor temperature continues to fall, the R to

W circuit is completed energizing the electric heat relays.

Heating (electric heat only)

PSC versions - When the thermostat calls for heating, the circuit from R to G is completed. The blower relay is energized. The circuit from R to W is completed energizing the heating contactor(s).

Constant torque version - When the thermostat calls for heating, the circuit from R to G is completed and the blower motor is energized directly by the 24VAC signal from the thermostat. The circuit from R to W is completed energizing the heating contactor(s).

Defrost

Supplemental heat during defrost can be provided by connecting the X2 (black) wire from the outdoor unit to W1 at the indoor unit. This will prevent cold air from being discharged from the indoor unit during defrost.

14. Operational and Checkout Procedures

To obtain proper performance, all units must be operated and charge adjustments made in accordance with procedures found in the Service Facts document of the outdoor unit. After

installation has been completed, it is recommended that the entire system be checked against the checkout list located at the back of this document. See "Checkout Procedures," p. 19

15. Maintenance

The system air filter(s) should be inspected, cleaned or replaced at least monthly. Make certain that the access panels are replaced and secured properly before placing the unit back in operation. This product is designed for dependable service; however, periodic maintenance should be scheduled and conducted by trained professional service personnel. This service should be conducted at least annually, and should include testing and inspection of electrical and refrigerant components. The heat transfer surface should be inspected for cleanliness. The blower motor is permanently lubricated for normal operating conditions.

To protect the coil, blower and other internal parts from excessive dirt and dust an air filter must be installed before air enters the evaporator coil. Consult the filter manufacturer for proper sizing and maximum velocity requirements.

Field Wiring

HEAT PUMP SYSTEMS

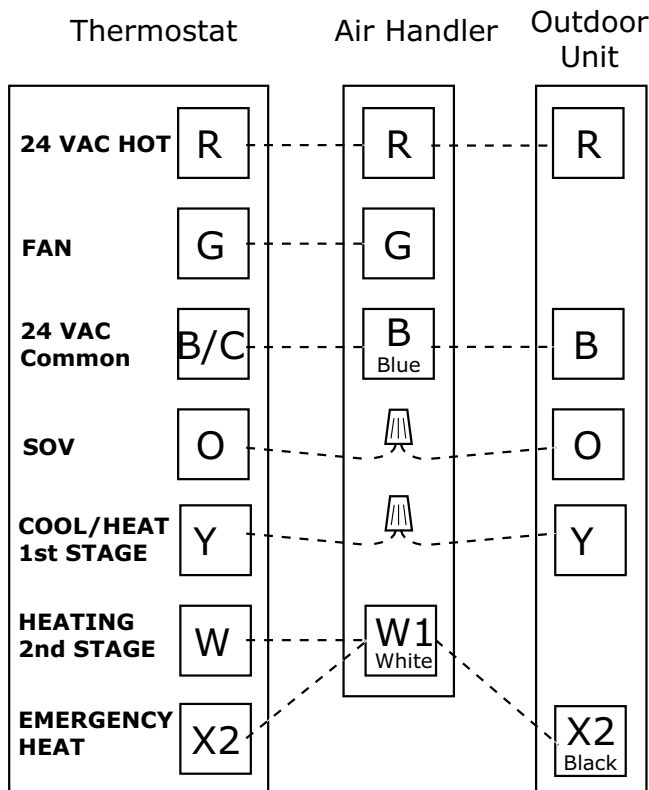

AC SYSTEMS

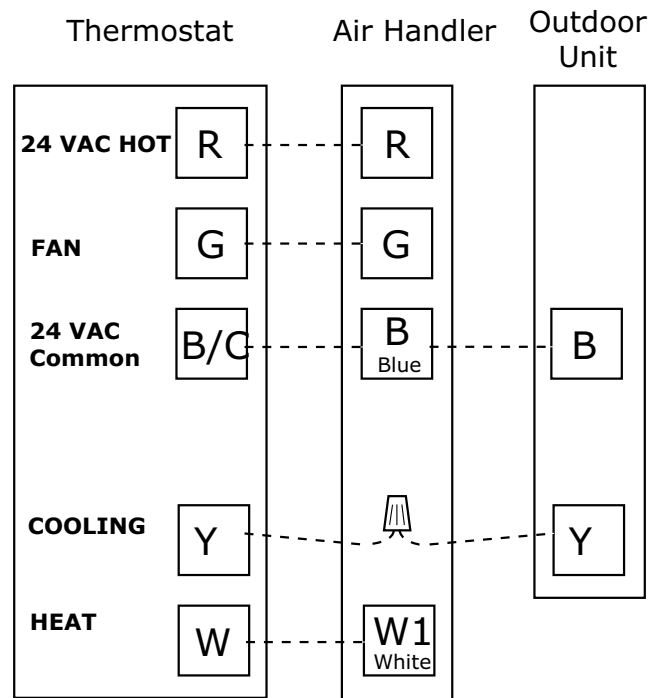

Electrical Data

Figure 1. PSC Motor Wiring Diagram for GMU2APB24, GMU2APB30, GMV2APB26, and GMV2APB32

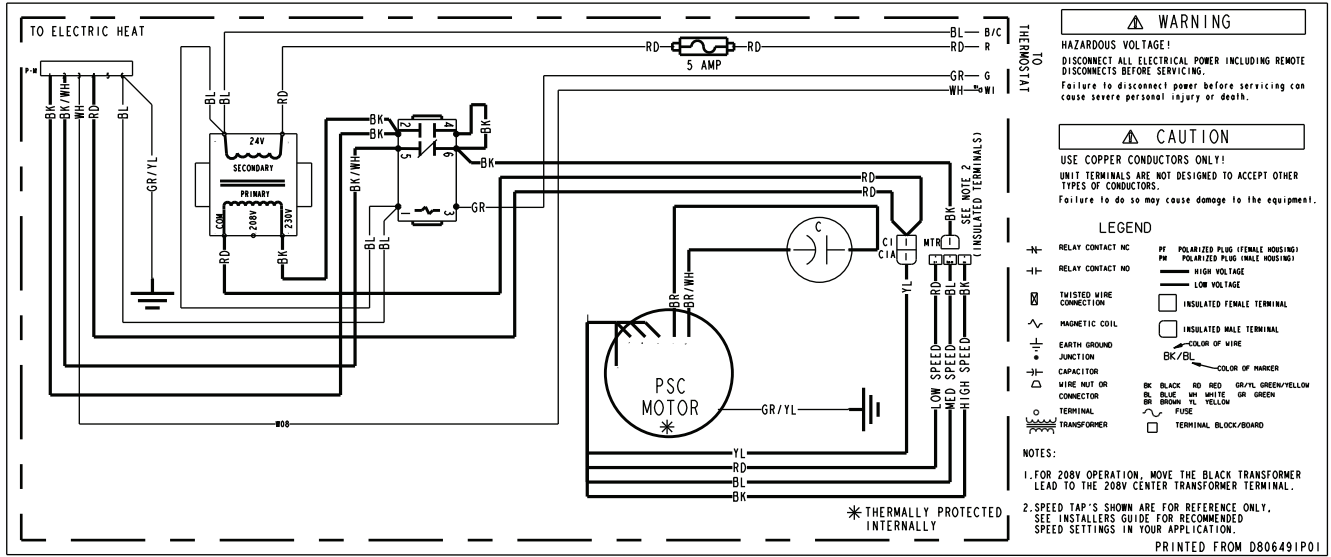

Figure 2. CTM Motor Wiring Diagram for GMU2AEB37 and GMV2AEB39

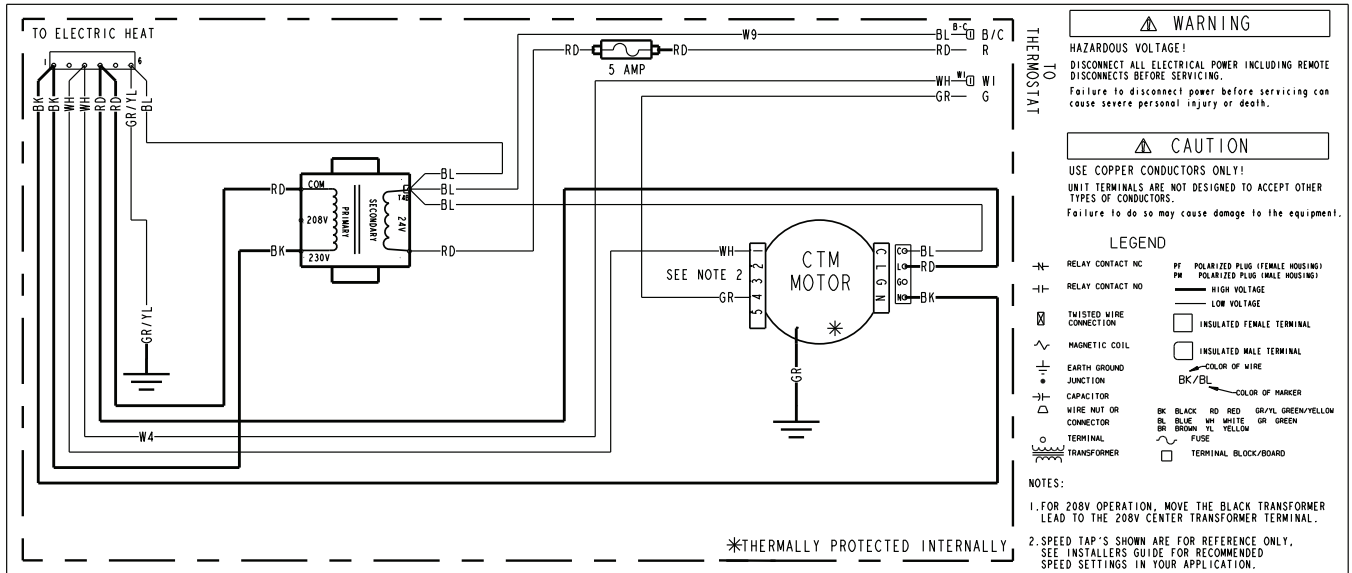
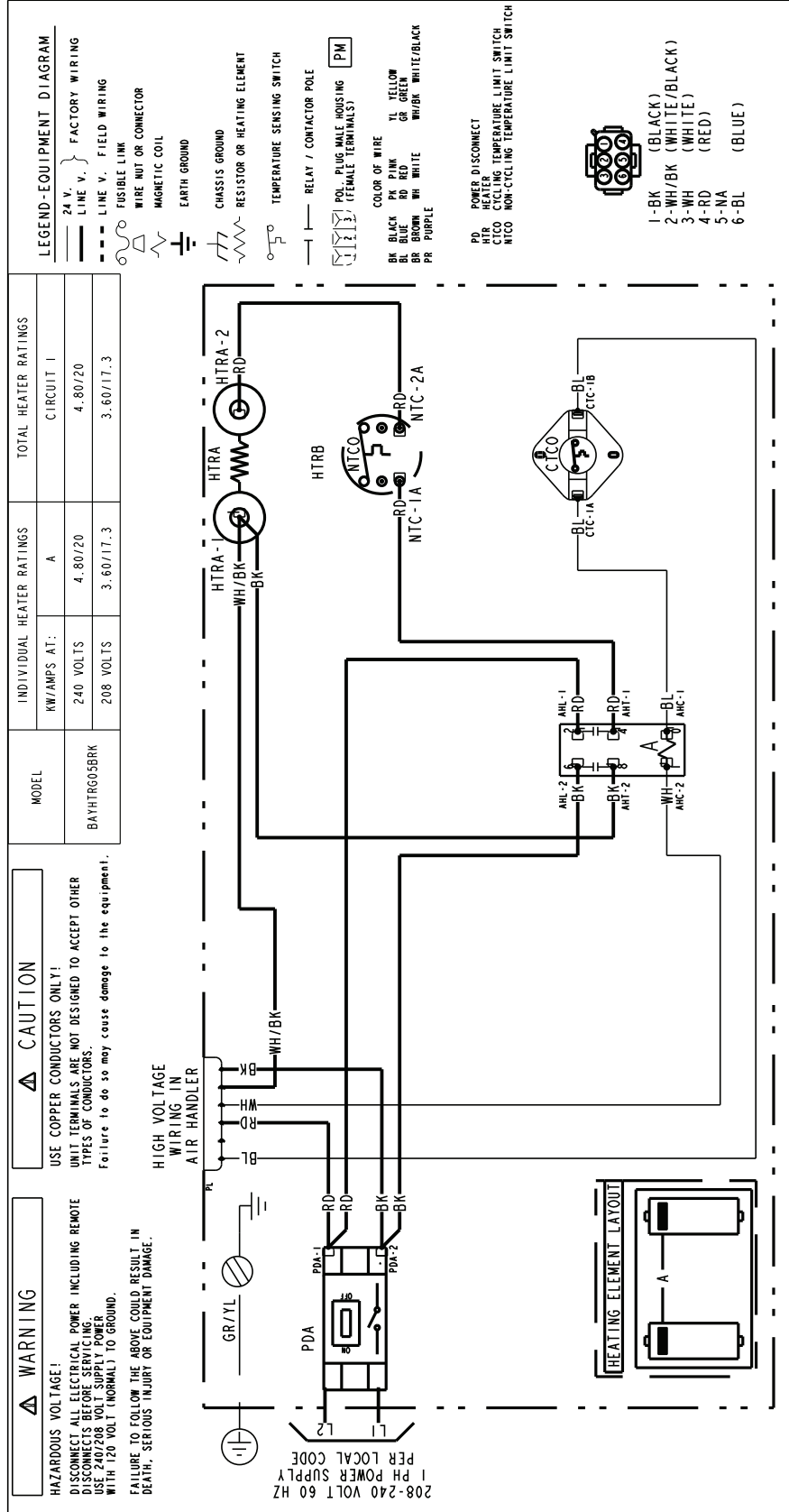
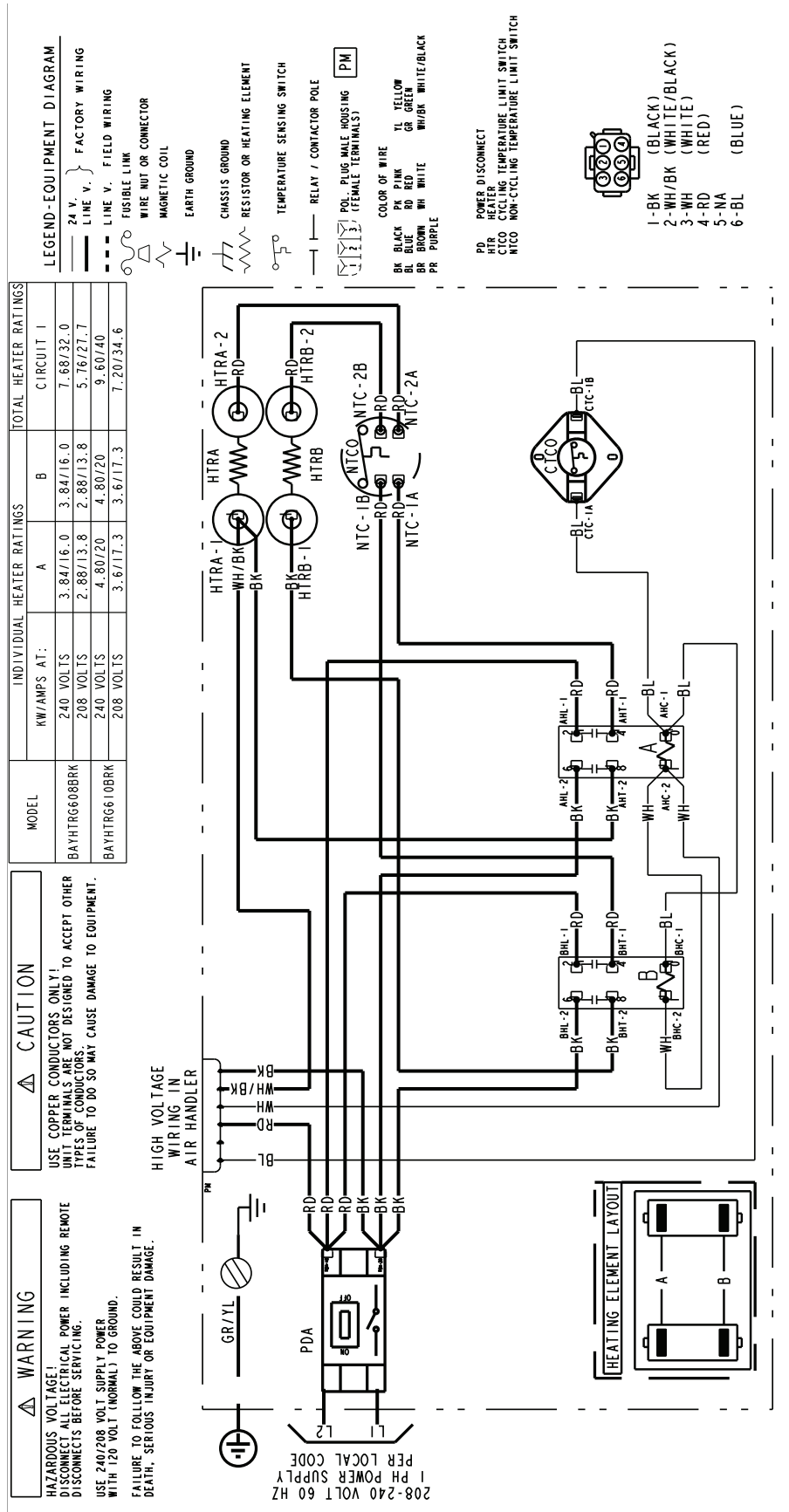

Figure 3. 5kW Heater Wiring for GMU2APB2405 and GMV2APB2605



PRINTED FROM D806718P01

Figure 4. 8kW and 10 kW Heater Wiring for GMU2APB2408, GMU2APB30, GMU2APB37, GMU2APB2608, GMU2APB32, and GMV2AEB38



Performance and Electrical Data

GMU2APB24051SA, GMU2APB24081SA						
External Static (in w.g.)	Airflow					
	Speed Taps - 230 Volts			Speed Taps - 208 Volts		
	High	Med †	Low	High	Med †	Low
0.1	1005.7	784.1	615.3	898.4	670.7	520.9
0.2	950.2	763.7	597.6	869.2	661.1	503.7
0.3	895.4	729.2	558.1	826.9	636.3	466.6
0.4	776.7	629.4	466.0	715.7	550.9	382.2
0.5	594.2	464.5	321.3	535.6	405.0	250.6
0.6	347.8	234.4		286.7	198.5	

Note:

1. Shaded boxes represent airflow outside the required 300-450 CFM/ton
2. Values are wet coil, no filter
3. CFM correction for dry coil = Add 3%
4. † = Factory default setting

Model No.	Heater Model No.	Number of Circuits / Phases	Motor Amps	Minimum Blower Speed		240 Volt				
				Without Heat Pump	With Heat Pump	Capacity		Heater Amps per Circuit	Minimum Circuit Ampacity	Maximum Overload Protection
						kW	BTUH			
GMU2APB24051SA	BAYHTRG605BRK	1/1	0.9	Low	N/A	4.8	16400	20	26	30
GMU2APB24081SA	BAYHTRG608BRK	2/1	0.9	Low	N/A	7.68	26200	32	41	45
Model No.	Heater Model No.	Number of Circuits / Phases	Motor Amps	Minimum Blower Speed		208 Volt				
				Without Heat Pump	With Heat Pump	Capacity		Heater Amps per Circuit	Minimum Circuit Ampacity	Maximum Overload Protection
						kW	BTUH			
GMU2APB24051SA	BAYHTRG605BRK	1/1	0.9	Low	N/A	3.6	12300	17.3	23	25
GMU2APB24081SA	BAYHTRG608BRK	2/1	0.9	Low	N/A	5.76	19700	27.7	36	40

GMV2APB26051SA, GMV2APB26081SA						
External Static (in w.g.)	Airflow					
	Speed Taps - 230 Volts			Speed Taps - 208 Volts		
	High	Med †	Low	High	Med †	Low
0.1	1020.5	784.5	613.9	903.2	669.3	520.7
0.2	973.3	769.6	598.4	878.7	662.9	506.9
0.3	936.4	741.5	564.3	858.9	643.6	474.4
0.4	832.3	647.8	478.4	770.6	563.4	393.5
0.5	661.1	488.4	340.9	614.0	422.3	264.3
0.6	422.8	263.3		389.0	220.3	

Note:

1. Shaded boxes represent airflow outside the required 300-450 CFM/ton
2. Values are wet coil, no filter
3. CFM correction for dry coil = Add 3%
4. † = Factory default setting

Performance and Electrical Data

Model No.	Heater Model No.	Number of Circuits / Phases	Motor Amps	Minimum Blower Speed		240 Volt				
				Without Heat Pump	With Heat Pump	Capacity		Heater Amps per Circuit	Minimum Circuit Ampacity	Maximum Overload Protection
						kW	BTUH			
GMV2APB26051SA	BAYHTRG605BRK	1/1	0.9	Low	Low	4.8	16400	20	26	30
GMV2APB26081SA	BAYHTRG608BRK	2/1	0.9	Low	Low	7.68	26200	32	43	45
Model No.	Heater Model No.	Number of Circuits / Phases	Motor Amps	Minimum Blower Speed		208 Volt				
				Without Heat Pump	With Heat Pump	Capacity		Heater Amps per Circuit	Minimum Circuit Ampacity	Maximum Overload Protection
						kW	BTUH			
GMV2APB26051SA	BAYHTRG605BRK	1/1	0.9	Low	Low	3.6	12300	17.3	23	25
GMV2APB26081SA	BAYHTRG608BRK	2/1	0.9	Low	Low	5.76	19700	27.7	36	40

GMU2APB30081SA						
External Static (in w.g.)	Airflow					
	Speed Taps - 230 Volts			Speed Taps - 208 Volts		
	High	Med †	Low	High	Med †	Low
0.1	1154.3	1086.0	1019.7	1139.6	1052.9	934.5
0.2	1091.6	1050.8	977.4	1073.2	1016.4	910.1
0.3	1037.4	996.2	932.2	1010.2	961.2	869.3
0.4	916.9	866.0	810.9	888.2	833.9	756.4
0.5	730.0	660.2	614.0	707.1	634.5	571.4
0.6	476.8	378.9		467.0	363.0	

Note:

1. Shaded boxes represent airflow outside the required 300-450 CFM/ton
2. Values are wet coil, no filter
3. CFM correction for dry coil = Add 3%
4. † = Factory default setting

Model No.	Heater Model No.	Number of Circuits / Phases	Motor Amps	Minimum Blower Speed		240 Volt				
				Without Heat Pump	With Heat Pump	Capacity		Heater Amps per Circuit	Minimum Circuit Ampacity	Maximum Overload Protection
						kW	BTUH			
GMU2APB30081SA	BAYHTRG608BRK	2/1	2.20	Low	N/A	7.68	26200	32	43	45
Model No.	Heater Model No.	Number of Circuits / Phases	Motor Amps	Minimum Blower Speed		208 Volt				
				Without Heat Pump	With Heat Pump	Capacity		Heater Amps per Circuit	Minimum Circuit Ampacity	Maximum Overload Protection
						kW	BTUH			
GMU2APB30081SA	BAYHTRG608BRK	2/1	2.20	Low	N/A	5.76	19700	27.7	37	40

GMV2APB32081SA						
External Static (in w.g.)	Airflow					
	Speed Taps - 230 Volts			Speed Taps - 208 Volts		
	High	Med †	Low	High	Med †	Low
0.1	1164.9	1104.4	1018.9	1130.7	1062.5	942.1
0.2	1095.5	1048.2	962.9	1063.6	994.1	903.2
0.3	1020.2	997.0	906.1	993.6	923.2	857.6
0.4	877.6	871.1	782.5	855.1	790.7	744.4
0.5	667.7	670.7	591.9	648.1	596.5	563.6
0.6	390.3	395.7		372.5	340.6	

Note:

1. Shaded boxes represent airflow outside the required 300-450 CFM/ton
2. Values are wet coil, no filter
3. CFM correction for dry coil = Add 3%
4. † = Factory default setting

Performance and Electrical Data

Model No.	Heater Model No.	Number of Circuits / Phases	Motor Amps	Minimum Blower Speed		240 Volt				
				Without Heat Pump	With Heat Pump	Capacity		Heater Amps per Circuit	Minimum Circuit Ampacity	Maximum Overload Protection
						kW	BTUH			
GMV2APB32081SA	BAYHTRG608BRK	2/1	2.20	Low	Low	7.68	26200	32	43	45
Model No.	Heater Model No.	Number of Circuits / Phases	Motor Amps	Minimum Blower Speed		208 Volt				
				Without Heat Pump	With Heat Pump	Capacity		Heater Amps per Circuit	Minimum Circuit Ampacity	Maximum Overload Protection
						kW	BTUH			
GMV2APB32081SA	BAYHTRG608BRK	2/1	2.20	Low	Low	5.76	19700	27.7	37	40

GMU2AEB37101SA					
External Static (in w. g.)	Airflow				
	Speed Taps - 208-230 Volts				
	High	Med-High †	Med	Med-Low	Low
0.1	1129.5	1074.5	965.3	782.6	613.2
0.2	1107.0	1048.9	936.3	752.1	578.1
0.3	1084.0	1023.3	908.0	718.6	538.9
0.4	1060.3	997.8	880.5	692.2	495.7
0.5	1035.9	972.5	853.6	642.8	448.4
0.6	1011.0	947.1	827.4	600.4	697.1
0.7	985.5	921.9	802.0	555.1	341.7

Note:

1. Shaded boxes represent airflow outside the required 300-450 CFM/ton
2. Values are wet coil, no filter
3. CFM correction for dry coil = Add 3%
4. † = Factory default setting

Model No.	Heater Model No.	Number of Circuits / Phases	Motor Amps	Minimum Blower Speed		240 Volt				
				Without Heat Pump	With Heat Pump	Capacity		Heater Amps per Circuit	Minimum Circuit Ampacity	Maximum Overload Protection
						kW	BTUH			
GMU2AEB37101SA	BAYHTRG610BRK	2/1	2.90	Low	N/A	9.6	32800	40	54	60
Model No.	Heater Model No.	Number of Circuits / Phases	Motor Amps	Minimum Blower Speed		208 Volt				
				Without Heat Pump	With Heat Pump	Capacity		Heater Amps per Circuit	Minimum Circuit Ampacity	Maximum Overload Protection
						kW	BTUH			
GMU2AEB37101SA	BAYHTRG610BRK	2/1	2.90	Low	N/A	7.2	24600	34.6	47	50

GMV2AEB39101SA					
External Static (in w. g.)	Airflow				
	Speed Taps - 208-230 Volts				
	High	Med-High †	Med	Med-Low	Low
0.1	1110.7	1059.0	947.9	779.8	610.0
0.2	1085.2	1033.0	919.9	750.3	574.0
0.3	1059.7	1007.3	892.5	717.5	535.2
0.4	1034.1	981.8	865.6	681.6	493.7
0.5	1008.6	956.8	839.2	642.3	449.4
0.6	983.0	932.1	813.3	599.9	402.4
0.7	957.4	907.6	788.0	554.2	352.6

Note:

1. Shaded boxes represent airflow outside the required 300-450 CFM/ton
2. Values are wet coil, no filter
3. CFM correction for dry coil = Add 3%
4. † = Factory default setting

Performance and Electrical Data

Model No.	Heater Model No.	Number of Circuits / Phases	Motor Amps	Minimum Blower Speed		240 Volt				
				Without Heat Pump	With Heat Pump	Capacity		Heater Amps per Circuit	Minimum Circuit Ampacity	Maximum Overload Protection
						kW	BTUH			
GMV2AEB39101SA	BAYHTRG610BRK	2/1	2.90	Low	M-L	9.6	32800	40	54	60
Model No.	Heater Model No.	Number of Circuits / Phases	Motor Amps	Minimum Blower Speed		208 Volt				
				Without Heat Pump	With Heat Pump	Capacity		Heater Amps per Circuit	Minimum Circuit Ampacity	Maximum Overload Protection
						kW	BTUH			
GMV2AEB39101SA	BAYHTRG610BRK	2/1	2.90	Low	M-L	7.2	24600	34.6	47	50

Fixed Orifice Superheat Charging Table

	Indoor Wet Bulb Temp (F)																														
	50	51	52	53	54	55	56	57	58	59	60	61	62	63	64	65	66	67	68	69	70	71	72	73	74	75	76	77	78		
Outdoor Dry Bulb Temperature (F)	55	7	9	10	11	12	14	15	17	18	20	21	23	24	26	27	29	30													
	60	5	7	8	9	10	12	13	15	16	18	19	21	22	24	25	27	28	30	31											
	65			4	6	8	10	11	13	14	16	17	18	19	21	22	24	25	27	28	27	31									
	70				5	7	8	10	11	13	14	16	17	18	19	21	22	24	25	27	28	30	31								
	75					5	6	7	9	10	12	14	16	18	19	21	22	24	26	28	29	31	32								
	80							4	6	7	9	10	11	12	14	16	18	19	21	23	25	26	28	29	31	33					
	85								4	6	7	9	10	13	14	16	18	20	21	23	24	26	28	29	30	31	32				
	90									4	6	8	10	11	13	14	16	18	20	22	24	25	27	28	30	31					
	95											4	6	8	10	13	14	16	18	20	22	23	25	26	28	29					
	100														6	8	10	12	13	16	18	20	21	23	25	27	29				
	105															4	6	7	9	11	13	15	18	20	22	24	26	28			
	110																4	7	9	11	13	16	18	21	23	26	28				
	115																		6	9	12	14	16	19	21	24	26				

Using a digital psychrometer, measure the return air wet-bulb temperature at the unit just before the coil. Also measure the outdoor dry-bulb temperature. Use these temperatures to locate the target superheat on the charging table. Do not attempt to charge the system if these conditions fall outside of this charging table.

ADD refrigerant to DECREASE total superheat. REMOVE refrigerant to INCREASE total superheat. Always allow 10 to 15 minutes of operation after any refrigerant or air flow change prior to determining the final superheat.

Outline Drawing

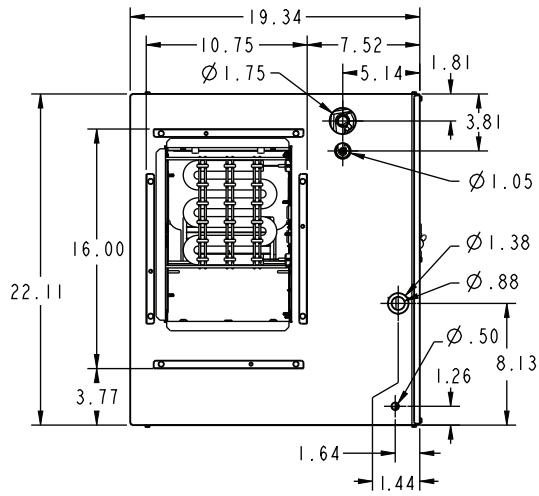

	To Combustible Material (Required)	Service Clearance (Recommended)
Sides	0"	0"
Front	0"	21"
Back	0"	0"
Outlet Duct & Plenum	0"	N/A
Condensate Piping Below Cabinet	N/A	3"
TXV/Orifice Above Unit	N/A	9"

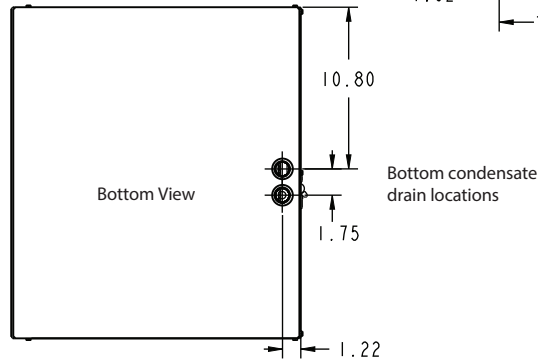
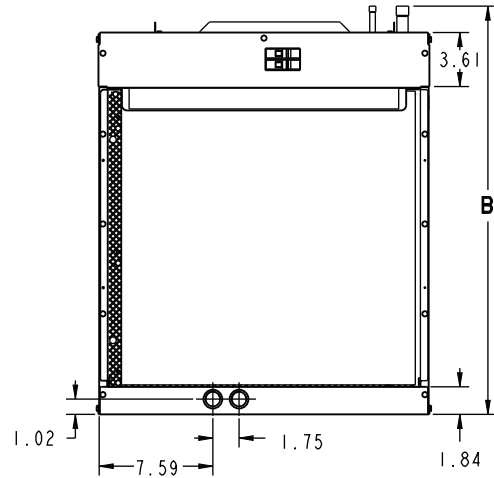
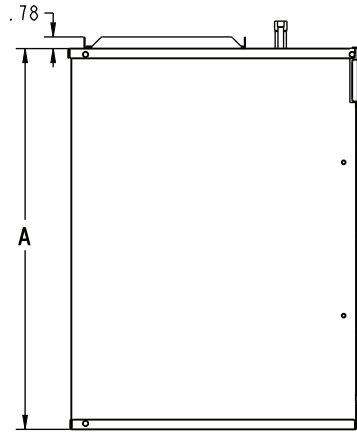

PRODUCT DIMENSIONS					
Air Handler Model	A	B	Gas Line Braze	Liquid Line Braze	Filter Size
GMU2APB24051SA, GMU2APB24081SA	25.43	27.26	3/4	3/8	20 x 20 x 1
GMU2APB30081SA, GMU2AEB37101SA	29.43	31.26	3/4	3/8	20 x 24 x 1
GMV2APB26051SA, GMV2APB26081SA	25.43	27.26	3/4	3/8 ^(a)	20 x 20 x 1
GMV2APB32081SA, GMV2AEB39101SA	29.43	31.26	3/4	3/8 ^(a)	20 x 24 x 1

All dimensions are in inches

^(a) Includes a mechanical fitting with a 3/8" braze connection.

Blower Serviceability

1. Remove all power to the air handler.

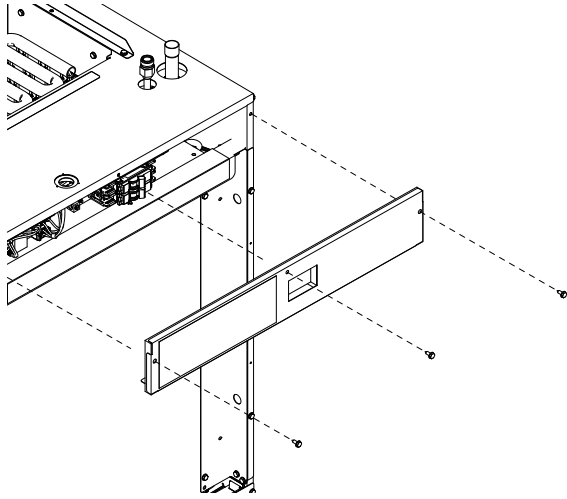

2. Remove the top breaker panel by removing three screws.

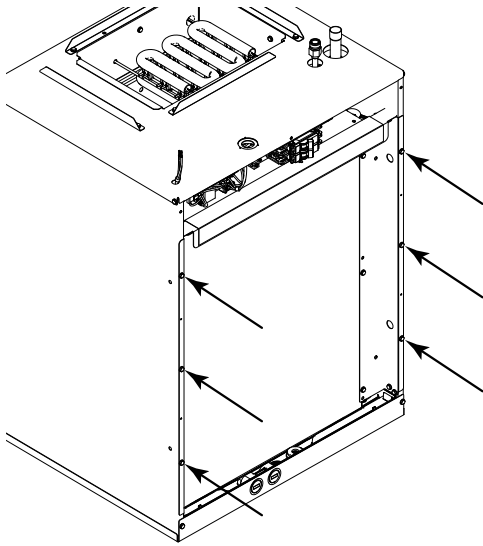

3. Remove the six screws shown in the illustration that secure the coil in place.

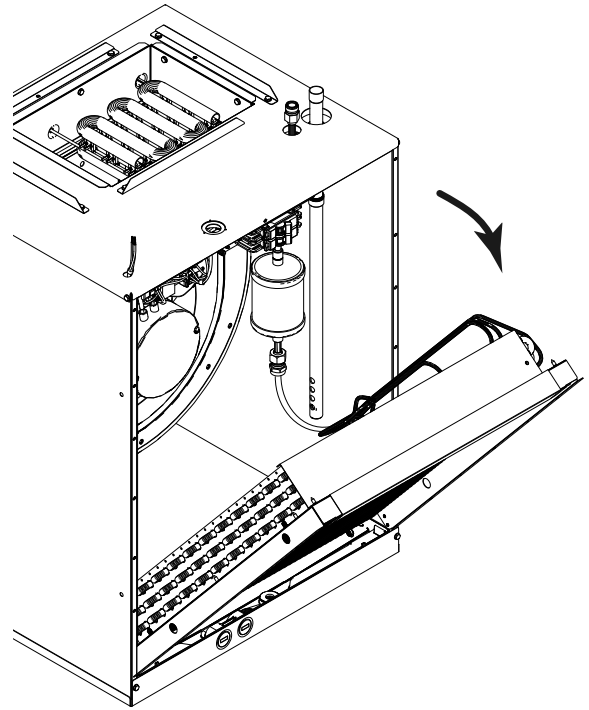

4. Tilt the coil outward. Built-in stops will limit this to 40 degrees.

Note: When tilting the coil, the lineset does not need to be disconnected. It is designed to withstand coil tilting.

Note: The coil and drain pan can be cleaned with a hose or sprayer when in the tilted position without removal from the air handler.

5. Remove the circuit breaker bracket screws if a circuit breaker is used.

Note: The circuit bracket assembly should hang out of the way. The wires connected to the circuit breaker do not need to be disconnected.

6. Disconnect the blower wiring.

Important: Make sure to mark the wires with connection points as they are removed to be able to reconnect later.

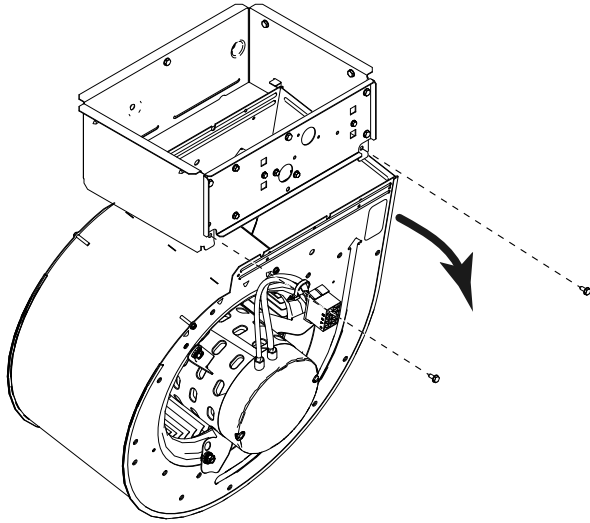

7. Remove the two screws holding the blower in place.
8. Tilt the front face of the blower downward to release from the electric heat housing.
9. Lower the blower assembly to clear wiring and obstructions. Maneuver the assembly over the evaporator coil and out of the cabinet.
10. Perform service as needed to blower. Reassemble the blower to the air handler following the steps in reverse order.

Checkout Procedures

The final phase of the installation is the system Checkout Procedures. The following list represents the most common items covered in a Checkout Procedure. Confirm all requirements in this document have been met.

- | | |
|--|--|
| <ul style="list-style-type: none"> <input type="checkbox"/> All wiring connections are tight and properly secured. <input type="checkbox"/> Voltage and running current are within limits. <input type="checkbox"/> All refrigerant lines (internal and external to equipment) are isolated, secure, and not in direct contact with each other or structure. <input type="checkbox"/> All braze connections have been checked for leaks. A vacuum of 350 microns provides confirmation that the refrigeration system is leak free and dry. <input type="checkbox"/> Final unit inspection to confirm factory tubing has not shifted during shipment. Adjust tubing if necessary so tubes do not rub against each other or any component when unit runs. <input type="checkbox"/> Ductwork is sealed and insulated. <input type="checkbox"/> All drain lines are clear with joints properly sealed. Pour water into drain pan to confirm proper drainage. Provide enough water to ensure drain trap is primed. | <ul style="list-style-type: none"> <input type="checkbox"/> Supply registers and return grilles are open, unobstructed, and air filter is installed. <input type="checkbox"/> Indoor blower and outdoor fan are operating smoothly and without obstruction. <input type="checkbox"/> Indoor blower motor set on correct speed setting to deliver required CFM. "Blower and fan set screws are tight." <input type="checkbox"/> Cover panels are in place and properly tightened. <input type="checkbox"/> For gas heating systems, manifold pressure has been checked and all gas line connections are tight and leak free. <input type="checkbox"/> For gas heating systems, flue gas is properly vented. <input type="checkbox"/> System functions safely and properly in all modes. <input type="checkbox"/> Owner has been instructed on use of system and given manual. |
|--|--|



Ingersoll Rand (NYSE: IR) advances the quality of life by creating comfortable, sustainable and efficient environments. Our people and our family of brands — including Club Car®, Ingersoll Rand®, Thermo King® and Trane® — work together to enhance the quality and comfort of air in homes and buildings; transport and protect food and perishables; and increase industrial productivity and efficiency. We are a global business committed to a world of sustainable progress and enduring results.



ingersollrand.com



Ingersoll Rand has a policy of continuous product and product data improvements and reserves the right to change design and specifications without notice.
We are committed to using environmentally conscious print practices.