

Installer's Guide

Single Packaged Gas/Electric 16 SEER Convertible, 3 - 5 Ton, 60 - 115 KBTU R-410A

ALL phases of this installation must comply with NATIONAL, STATE AND LOCAL CODES

IMPORTANT — This Document is customer property. Please return to service information pack and give this Installer's Guide to the homeowner upon completion of work.

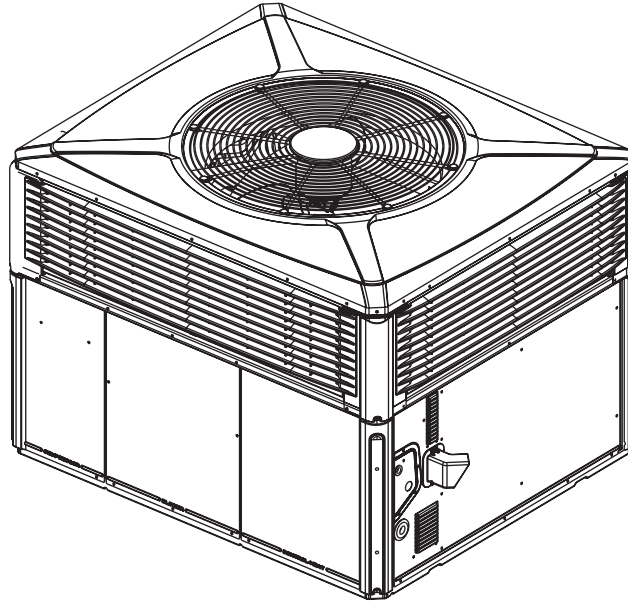

4YCZ6036 through 4YCZ6060

⚠ WARNING

SAFETY HAZARD!

This information is for use by individuals having adequate backgrounds of electrical and mechanical experience. Any attempt to repair a central air conditioning product may result in personal injury and/or property damage. The manufacturer or seller cannot be responsible for the interpretation of this information, nor can it assume any liability in connection with its use.

⚠ WARNING

HAZARDOUS VOLTAGE, MOVING PARTS, AND GAS!

Bodily injury can result from high voltage electrical components, fast moving fans, and combustible gas. For protection from these inherent hazards during installation and service, the electrical supply must be disconnected and the main gas valve must be turned off. If operating checks must be performed with the unit operating, it is the technician's responsibility to recognize these hazards and proceed safely.

⚠ WARNING

HAZARDOUS GASSES!

Exposure to fuel substances, or by-products of incomplete fuel combustion, is believed by the state of California to cause cancer, birth defects, or other reproductive harm.

This warning complies with State of California law, Proposition 65.

This product must be gas piped by a Licensed Plumber or Gas Fitter in the Commonwealth of Massachusetts.

⚠ WARNING

SAFETY HAZARD!

Do not operate the unit without the evaporator fan or coil access panels in place. Reinstall the access panels after performing maintenance procedures on the fan. Operating the unit without the access panels properly installed may result in severe personal injury or death.

⚠ WARNING: HAZARDOUS VOLTAGE - DISCONNECT POWER and DISCHARGE CAPACITORS BEFORE SERVICING

Installer's Guide

Safety Considerations

IMPORTANT: Read this entire manual before beginning installation procedures.

NOTICE

Warning and Cautions appear at appropriate locations throughout this guide. Read these carefully.

⚠ WARNING: INDICATES A POTENTIALLY HAZARDOUS SITUATION WHICH, IF NOT AVOIDED, COULD RESULT IN DEATH OR SERIOUS INJURY.

⚠ CAUTION: Indicates a potentially hazardous situation which, if not avoided, may result in minor or moderate injury. It may also be used to alert against unsafe practices and where property-damage-only accidents could occur.

⚠ WARNING

This product contains fiberglass wool insulation! Fiberglass dust and ceramic fibers are believed by the state of California to cause cancer through inhalation. Glasswool fibers may also cause respiratory, skin, or eye irritation.

PRECAUTIONARY MEASURES

- Avoid breathing fiberglass dust
- Use a NIOSH approved dust/mist respirator
- Avoid contact with the skin or eyes. Wear long-sleeved, loose fitting clothing, gloves, and eye protection.
- Wash clothes separately from other clothing, rinse washer thoroughly.
- Operations, such as sawing, blowing, tear-out, and spraying may generate fiber concentrations requiring additional respiratory protection. Use the appropriate NIOSH approved respirator in these situations.

FIRST AID MEASURES

- Eye Contact:** Flush eyes with water to remove dust. If symptoms persist, seek medical attention.
- Skin Contact:** Wash affected area gently with soap and warm water after handling.

⚠ WARNING

EXPLOSION HAZARD!

Propane gas is heavier than air and may collect in any low areas or confined spaces. In addition, odorant fade may make the gas undetectable except with a warning device. If the gas furnace is installed in a basement, an excavated area or a confined space, it is strongly recommended to contact a gas supplier to install a gas detecting warning device in case of leak. The manufacturer of your furnace does not test any detectors and makes no representations regarding any brand or type of detector.

⚠ WARNING

EXPLOSION HAZARD!

To prevent an explosion or possible injury, death, and equipment damage, do not store combustible materials, gasoline, or other flammable vapors or liquids near the unit.

⚠ CAUTION

CONTAINS REFRIGERANT!
SYSTEM CONTAINS OIL AND REFRIGERANT UNDER HIGH PRESSURE. RECOVER REFRIGERANT TO RELIEVE PRESSURE BEFORE OPENING SYSTEM. Failure to follow proper procedures can result in personal illness or injury or severe equipment damage.

⚠ CAUTION

RECONNECT ALL GROUNDING DEVICES.
All parts of this product that are capable of conducting electrical current are grounded. If grounding wires, screws, straps, clips, nuts, or washers used to complete a path to ground are removed for service, they must be returned to their original position and properly fastened.

⚠ CAUTION

Unit contains R-410A Refrigerant!
R-410A operating pressure exceeds the limit of R-22. Proper service equipment is required. Failure to use proper service tools may result in equipment damage or personal injury.
SERVICE
Use only R-410A Refrigerant and approved POE compressor oil.

⚠ CAUTION

Hot Surface!
Do Not touch top of compressor. May cause minor to severe burning.

⚠ CAUTION

Never use combustible cleaning fluids on any part of the furnace.

⚠ CAUTION

Caution must be taken at all times to avoid personal injuries and/or damage to equipment.

IMPORTANT: This product has been designed and manufactured to meet ENERGY STAR criteria for energy efficiency. However, proper refrigerant charge and proper air flow are critical to achieve rated capacity and efficiency. Installation of this product should follow the manufacturer's refrigerant charging and air flow instructions. **Failure to confirm proper charge and airflow may reduce energy efficiency and shorten equipment life.**

IMPORTANT: Do not connect gas piping to the unit until a line pressure test has been completed. This unit should never be exposed to gas line pressure in excess of 14 inches water column (1/2 PSIG). The furnace and its equipment shutoff valve must be disconnected from the gas supply piping system during any pressure testing of that system at test pressures in excess of 1/2 psi.

IMPORTANT: Reconnect all grounding devices. All parts of this product capable of conducting electrical current are grounded. If grounding wires, screws, straps, clips, nuts, or washers used to complete a path to ground are removed for service, they must be returned to their original position and properly fastened.

IMPORTANT: Wear appropriate gloves, arm sleeve protectors, and eye protection when servicing or maintaining this equipment.

IMPORTANT: Air filters and media wheels or plates shall meet the test requirements in UL 900.

Contents

Safety Considerations	2
Introduction	3
Step 1-Inspect Shipment	3
Step 2-Determine Unit Clearances	4
Step 3-Review Location and Recommendation Information	10
Step 4-Unit Installation	11
Install Flue Hood	11
Ground Level Installation	11
Rooftop Installation -- Curb Mounting	11
Covert Horizontal Airflow to Down Airflow	11
Install Full Perimeter Roof Mounting Curb	11
Lifting and Rigging	12
Placing the Unit on the Mounting Curb	12
Rooftop Installation -- Frame Mounting	13
Rooftop Installation -- No Frame/Curb	13
Ductwork Installation	16
Attaching Downflow Ductwork to Roof Curb	16
Attaching Downflow Ductwork to Roof Frame	16
Attaching Horizontal Ductwork to Unit	16
Condensate Drain Piping	16
Gas Piping Installation	16
Pipe Delivery Schedule (natural gas only)	17
Gas Pressure Set-up Precautions	17
Gas Supply Line Pressure (all fuels)	17
Verify Manifold Pressure	18
Input Check and Adjustment	18
High Altitude Installation	19
Air Filter Installation	19
Electrical Wiring	19
Electrical Connections	18
Electrical Power	19
Disconnect Switch	19
Over current Protection	19
Power Wiring	19
Control Wiring (Class II)	20
Thermostat Heat Anticipator	20
Step 5-Unit Startup	20
Pre-start Quick Checklist	20
Field Wiring Diagram	21
Starting the Unit in the Cooling Mode	22
Operating Pressures	22
Voltage Check	22
Cooling Shutdown	22
Starting the Unit in Gas Heating Mode	22
Final Installation Checklist	22
Sequence of Operation	23
Maintenance	24
Owner Maintenance	24
Filters	24
Service Maintenance	25
Cooling Season	24
Heating Season	24
Manifold Pressure Check and Adjust	25
Flue Hood and Combustion Blower Cleaning	25
Status LEDs	26

Introduction

Read this manual carefully before attempting to install, operate, or perform maintenance on this unit. Installation and maintenance should be performed by qualified service technicians only. Do NOT use this furnace for temporary heating of buildings under construction.

As shipped from the factory, this unit is for use with natural gas only. It is listed by Underwriters Laboratory. An LP Gas conversion kit is available. Extreme mounting kits for slab and curbs are also available.

Packaged units are designed for outdoor mounting with a vertical condenser discharge. They can be located either at ground level or on a roof in accordance with local codes or National Fuel Gas Code (ANSI-Z223.1A) Latest Revision. Since these units are designed exclusively for outdoor operation, additional flue venting systems are not required. Each unit contains an operating charge of refrigerant as shipped. Extreme mounting kits are available for slab (BAYEX-MK003A), utility curb (BAYEXMK002B), or curb (BAYEX-MK001A) mountings.

This guide is organized as follows:

- Step 1- Inspect Shipment
- Step 2- Determine Unit Clearances
- Step 3- Review Location and Recommendation Information
- Step 4- Unit Installation
- Step 5- Unit Startup
- Sequence of Operation
- Maintenance

Step 1—Inspect Shipment

1. Check for damage after the unit is unloaded. Report promptly to the carrier any damage found to the unit. Do not drop the unit.

IMPORTANT: To prevent damage to the sides and top of the unit when hoisting, retain the top shipping skid on the unit or use "spreader bars" as shown on page 14.

2. Check the unit nameplate to determine if the unit is correct for the intended application. The power supply must be adequate for the unit and all accessories.
3. Check to be sure the refrigerant charge has been retained during shipment. Remove the Compressor access panel to access the 1/4" flare pressure taps.
4. The Flue Hood is included with the unit's literature pack.
5. If this unit is being installed on a curb, verify that the correct curb is provided for the unit.
 - 4YCZ6036 uses model BAYCURB050.
 - 4YCZ6048 and 4YCZ6060 use model BAYCURB051.
6. If the unit is being hoisted, accessory kit BAYLIFT002B is recommended. It includes a kit of four (4) lifting lugs and instructions.

NOTE: If practical, install any internal accessories to the unit at the shop.

Installer's Guide

Step 2—Determine Unit Clearances

Figures 1 through 6 show the unit critical dimensions.

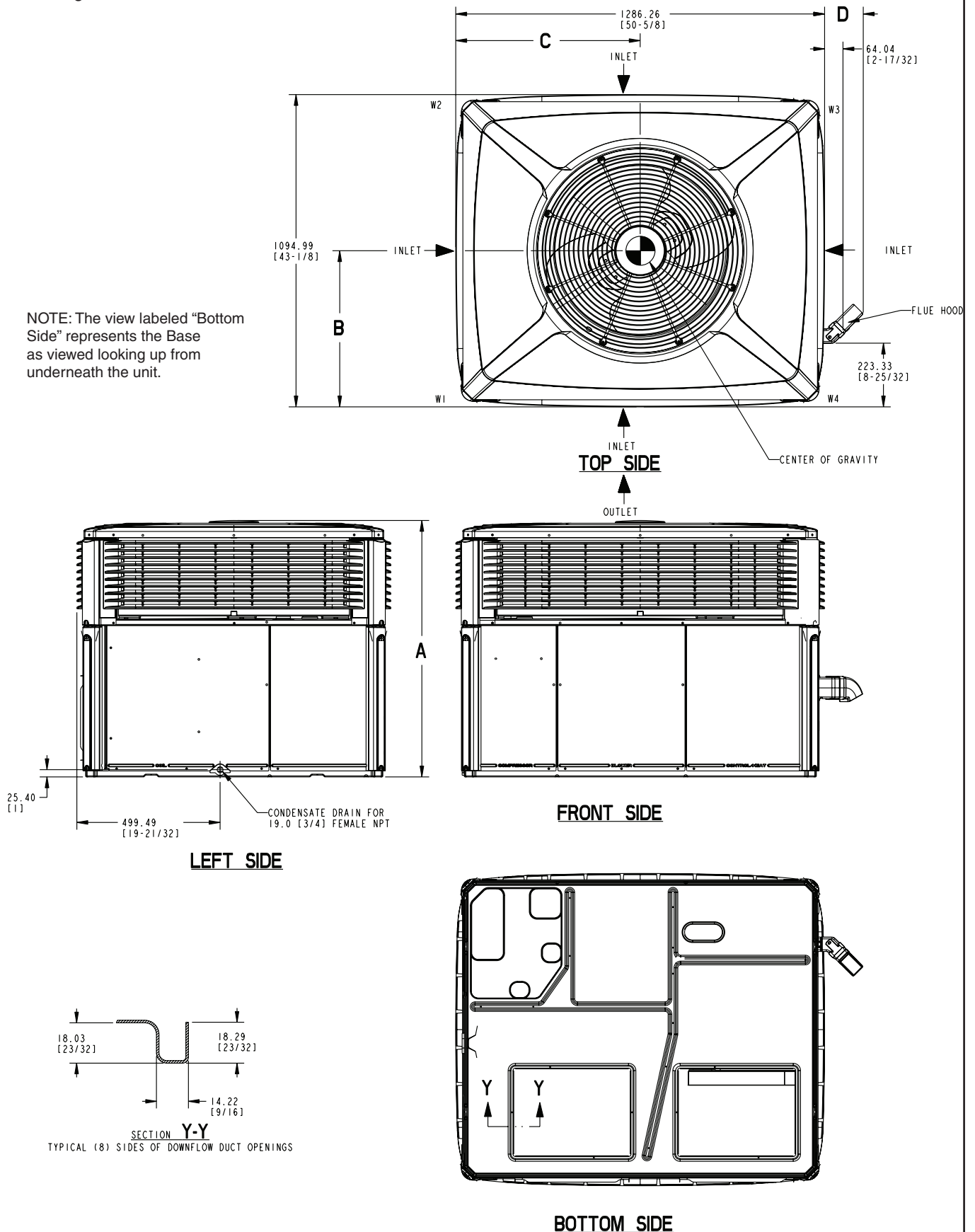
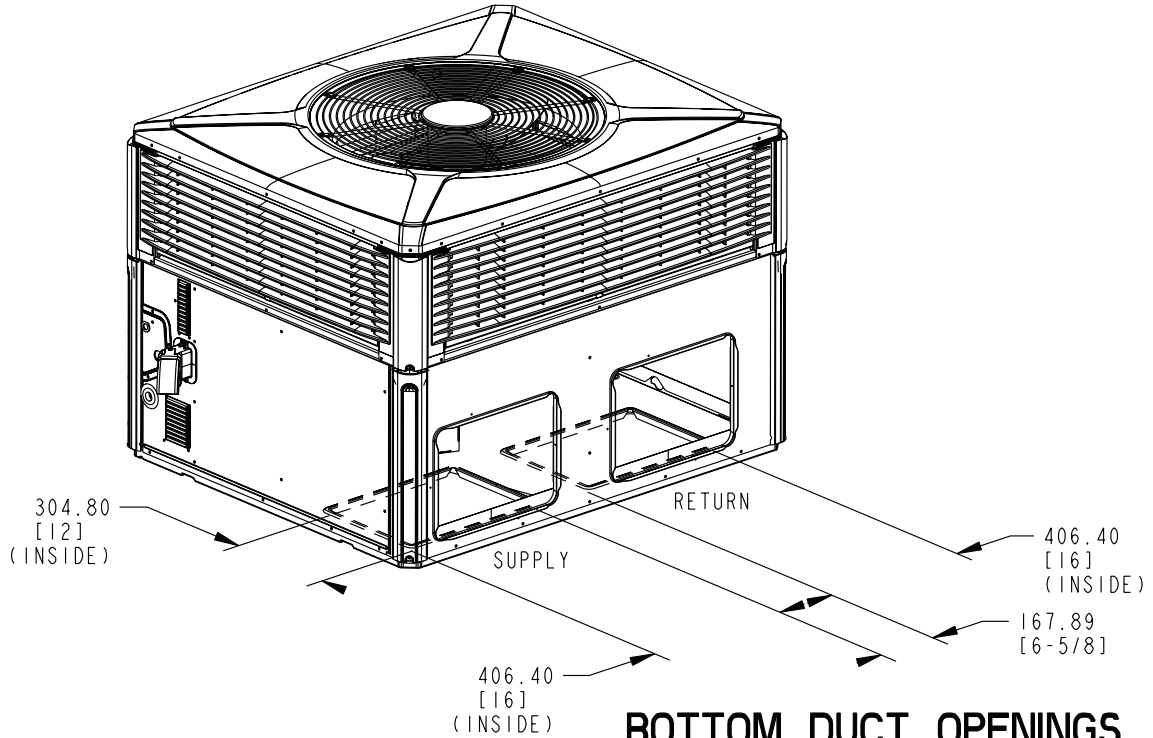

Figure 1. 4YCZ6036 (1 of 3)



BOTTOM DUCT OPENINGS

RECOMMENDED SERVICE CLEARANCE MM/IN.		
		WITH ECONOMIZER
BACK SIDE	304.8 [12]	762.0 [30]
LEFT SIDE	762.0 [30]	914.4 [36]
RIGHT SIDE	914.4 [36]	-
FRONT SIDE	1066.8 [42]	-

CLEARANCE TO COMBUSTIBLE MATERIAL MM/IN.	
BOTTOM	0
BACK SIDE	25.4 [1]
LEFT SIDE	152.4 [6]
RIGHT SIDE	304.8 [12]
FRONT SIDE	304.8 [12]
TOP	914.4 [36]

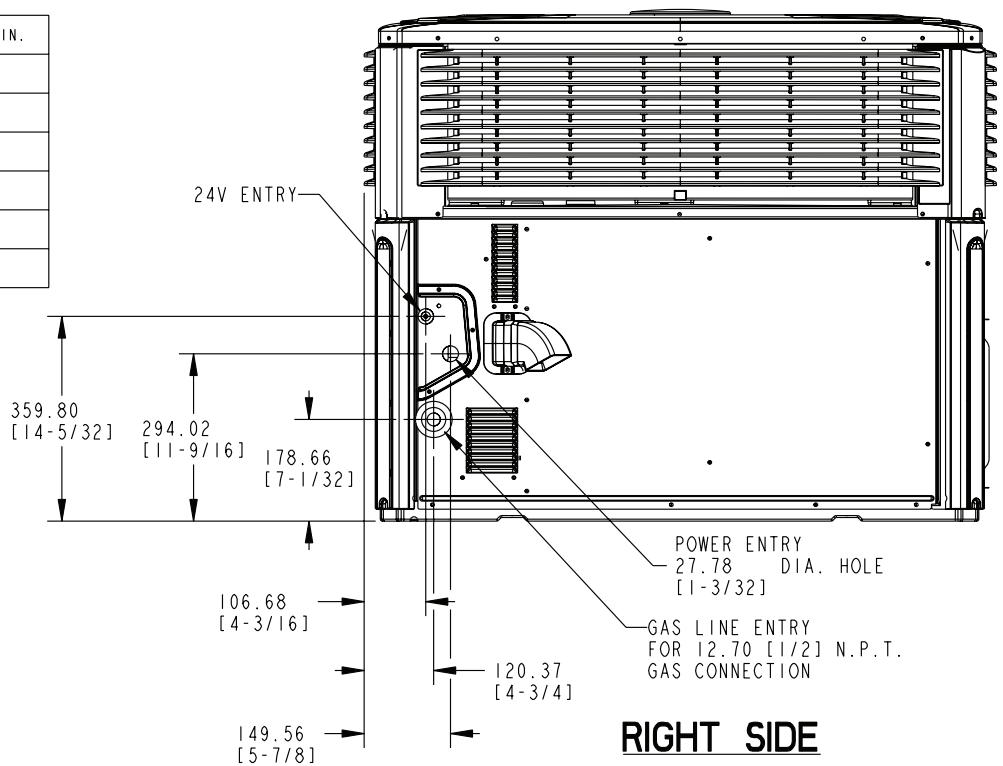

RIGHT SIDE

Figure 2. 4YCZ6036 (2 of 3)

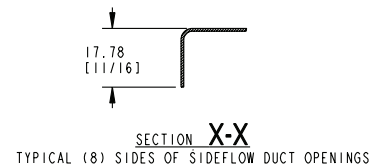
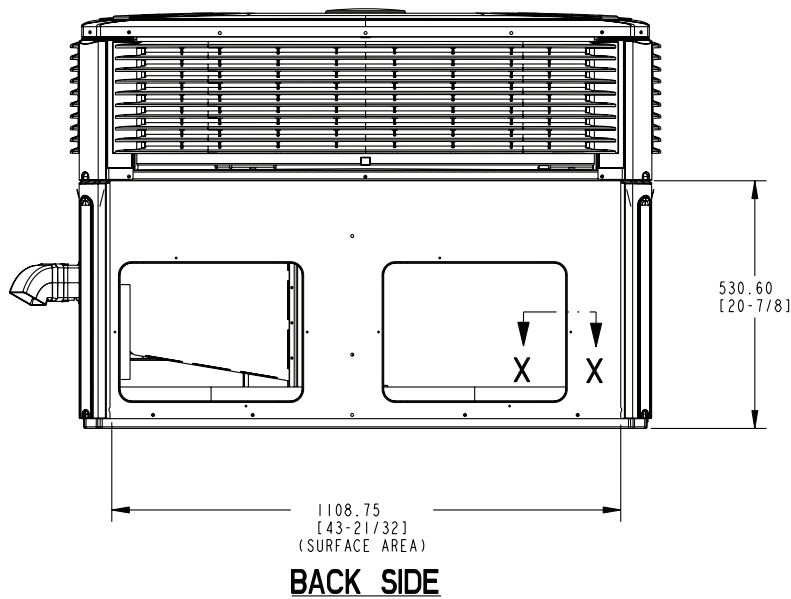
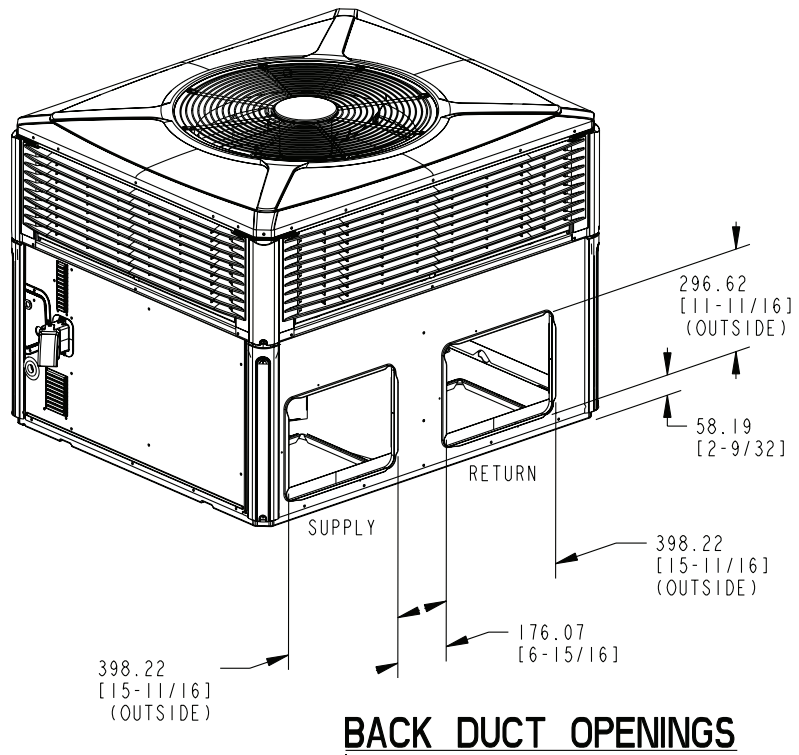

MODEL	HEIGHT MM/IN.	FLUE HOOD W/BRKT MM/IN.	APPROX. CORNER WEIGHT - KG/LBS				SHIPPING WEIGHT KG/LBS	TOTAL UNIT WEIGHT KG/LBS	CENTER OF GRAVITY MM/IN.	
	A		D	W1	W2	W3			W4	B
4YCY4024 (060)	903.29 [35-9/16]	-	59.0 [130]	37.2 [82]	31.3 [69]	48.5 [107]	218.4 (481)	174.8 [385]	401.3 [15.8]	546.1 [21.5]
4YCY4030 (070)										
4YCY4036/4YCY26036 (070)	949.99 [37-3/8]	117.86 [4-5/8]	60.3 [133]	36.3 [80]	30.4 [67]	50.3 [111]	221.6 (488)	178.0 [392]	388.6 [15.3]	558.8 [22.0]
4YCY4036/4YCY26036 (090)										
4DCY4024 (060)	903.29 [35-9/16]	-	60.8 [134]	38.1 [84]	31.3 [69]	48.5 [107]	218.4 (481)	174.8 [385]	398.8 [15.7]	546.1 [21.5]
4DCY4030 (070)										
4DCY4036/4DC26036 (070)	949.99 [37-3/8]	117.86 [4-5/8]	62.1 [137]	37.2 [82]	30.4 [67]	50.3 [111]	221.6 (488)	178.0 [392]	386.1 [15.2]	558.8 [22.0]

Figure 3. 4YCY26036 (3 of 3)

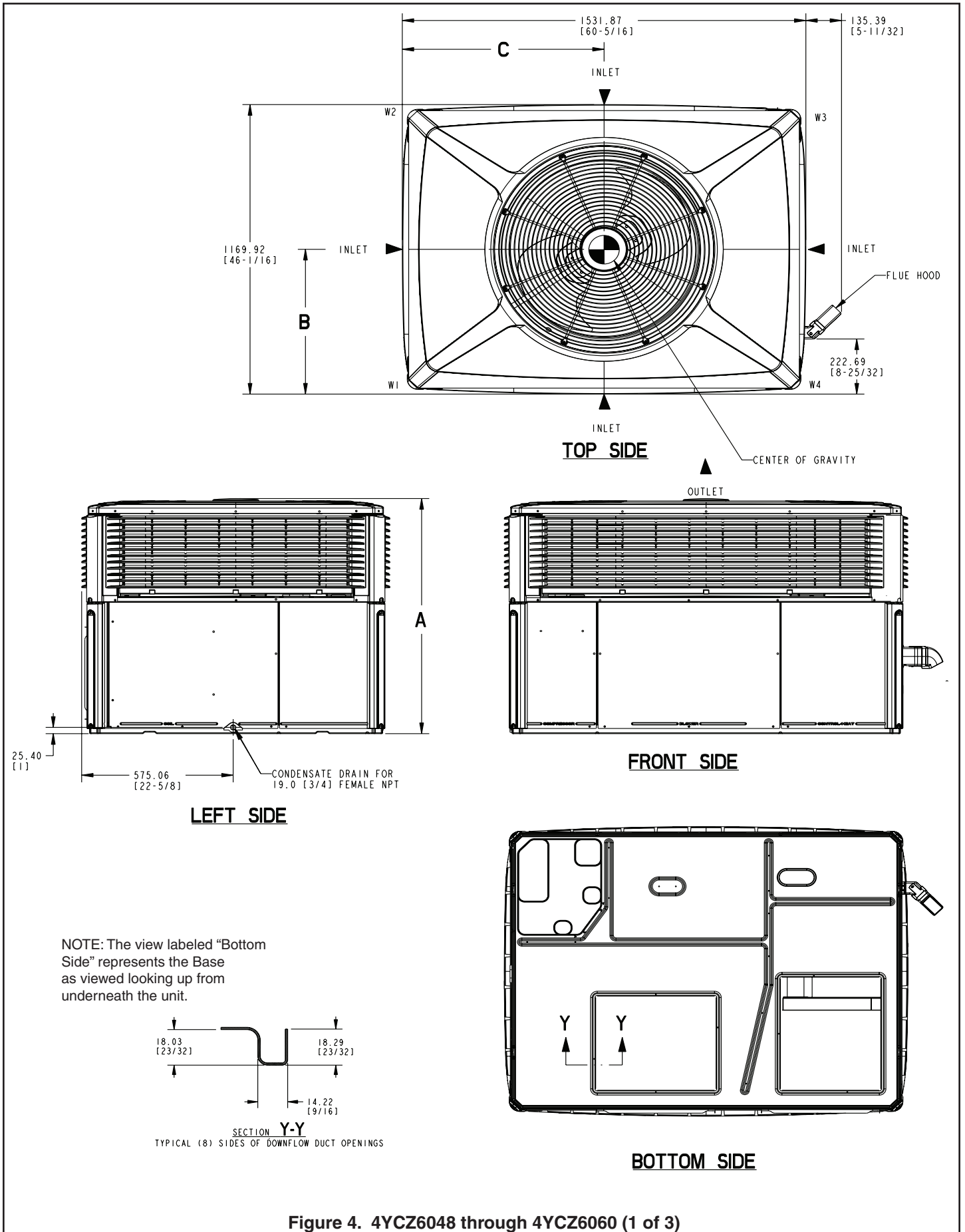
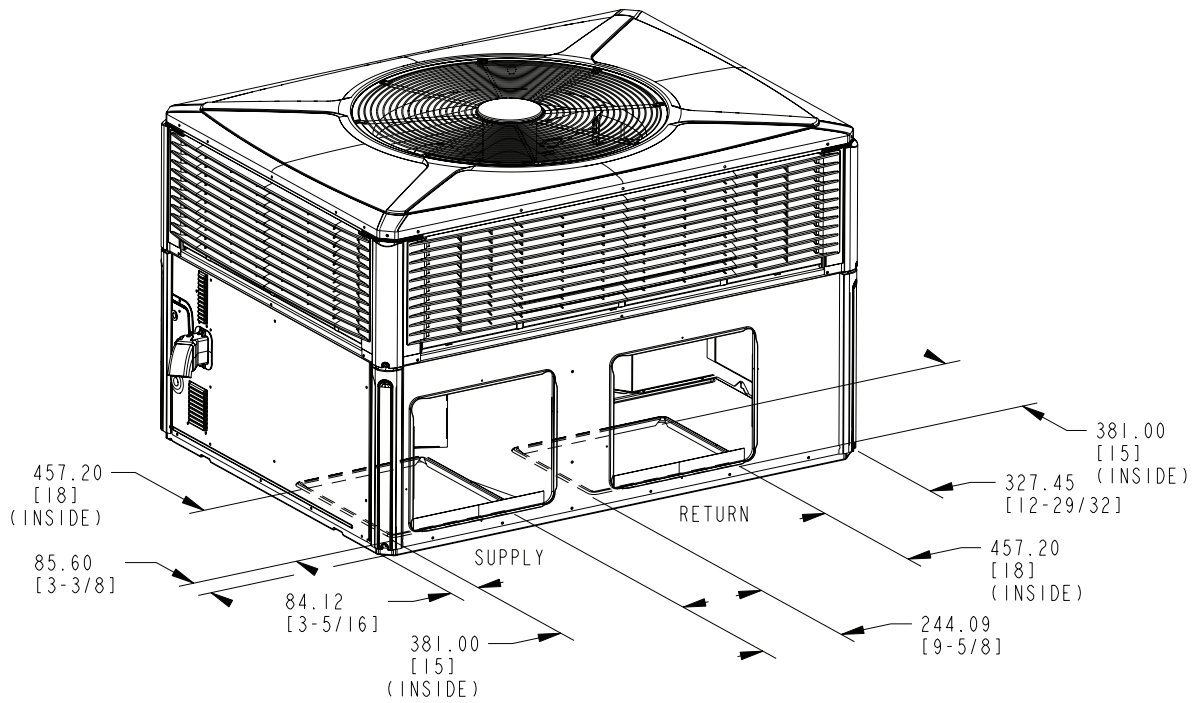

Figure 4. 4YCZ6048 through 4YCZ6060 (1 of 3)



BOTTOM DUCT OPENINGS

RECOMMENDED SERVICE CLEARANCE MM/IN.		
		WITH O.A. DAMPER/ECON.
BACK SIDE	304.8 [12]	762.0 [30]
LEFT SIDE	914.4 [36]	1066.8 [42]
RIGHT SIDE	914.4 [36]	-
FRONT SIDE	1066.8 [42]	-

CLEARANCE TO COMBUSTIBLE MATERIAL MM/IN.	
BOTTOM	0
BACK SIDE	25.4 [1]
LEFT SIDE	152.4 [6]
RIGHT SIDE	304.8 [12]
FRONT SIDE	304.8 [12]
TOP	914.4 [36]

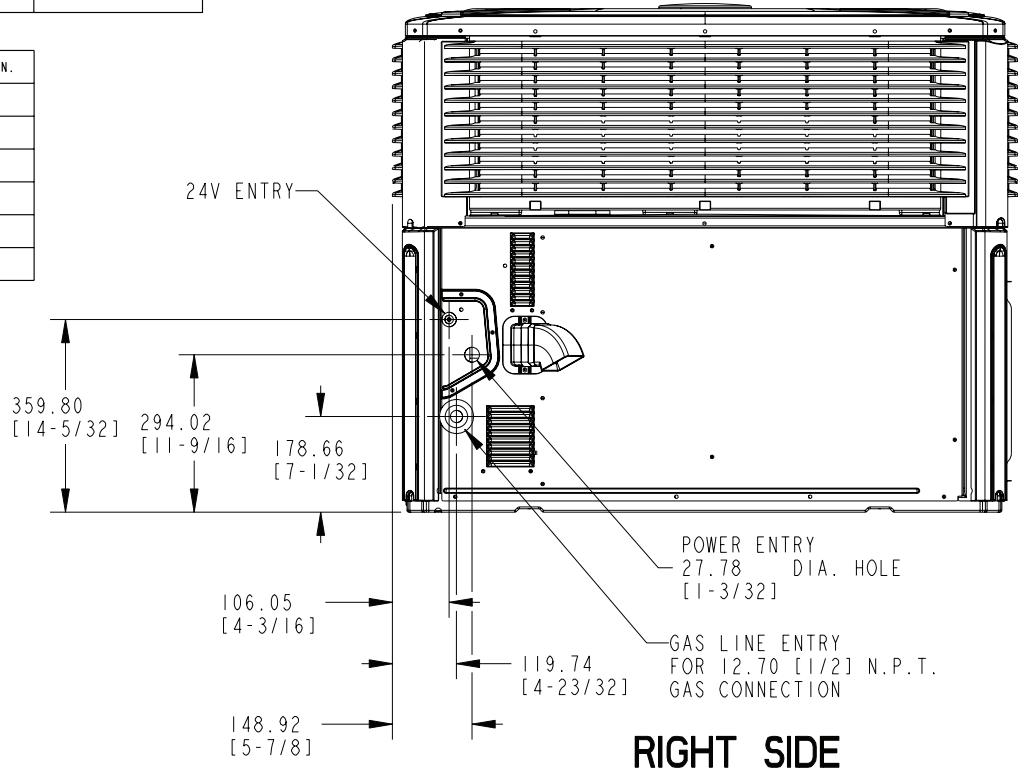
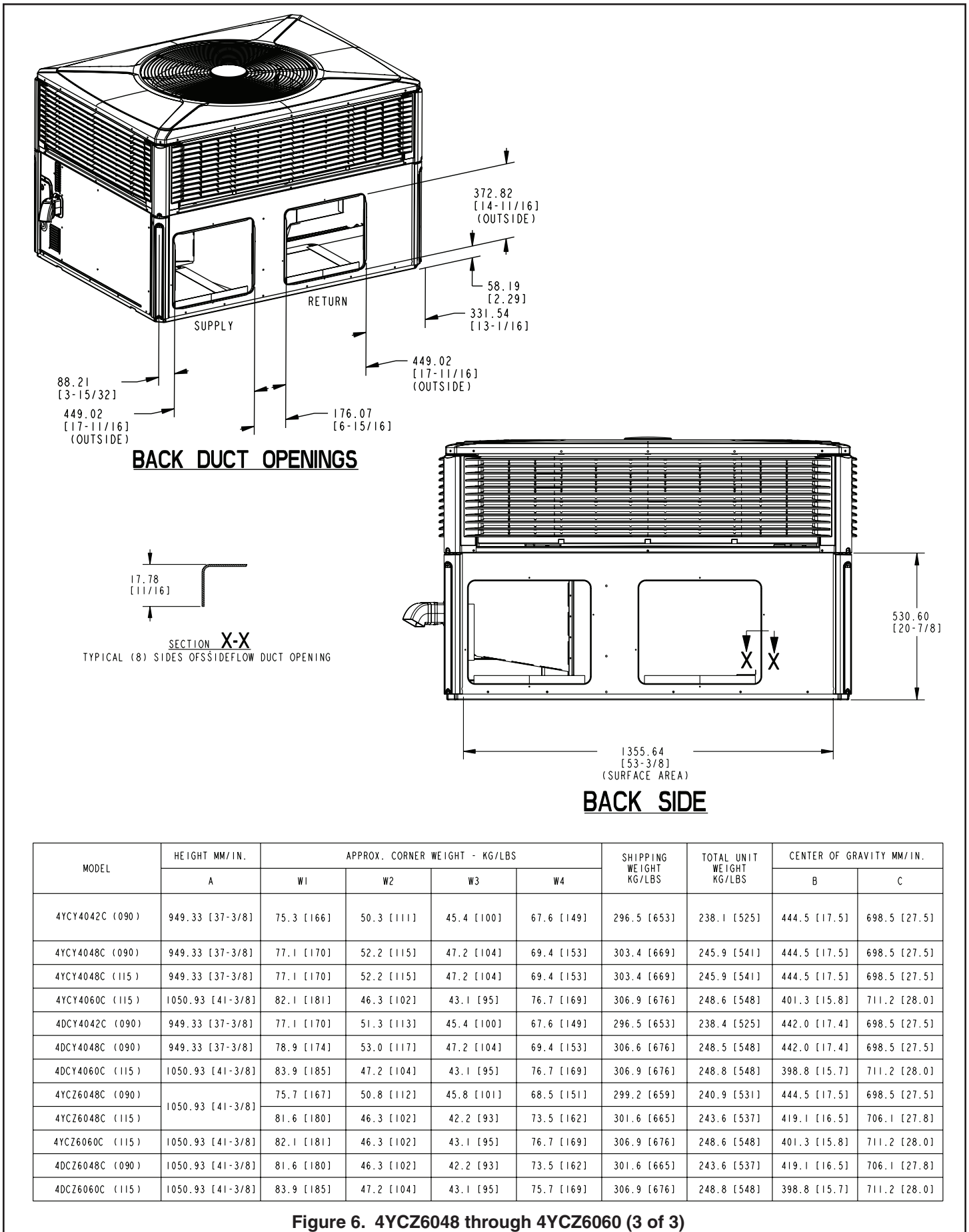

Figure 5. 4YCZ6048 through 4YCZ6060 (2 of 3)



MODEL	HEIGHT MM/IN.	APPROX. CORNER WEIGHT - KG/LBS				SHIPPING WEIGHT KG/LBS	TOTAL UNIT WEIGHT KG/LBS	CENTER OF GRAVITY MM/IN.	
	A	W1	W2	W3	W4			B	C
4CY4042C (090)	949.33 [37-3/8]	75.3 [166]	50.3 [111]	45.4 [100]	67.6 [149]	296.5 [653]	238.1 [525]	444.5 [17.5]	698.5 [27.5]
4CY4048C (090)	949.33 [37-3/8]	77.1 [170]	52.2 [115]	47.2 [104]	69.4 [153]	303.4 [669]	245.9 [541]	444.5 [17.5]	698.5 [27.5]
4CY4048C (115)	949.33 [37-3/8]	77.1 [170]	52.2 [115]	47.2 [104]	69.4 [153]	303.4 [669]	245.9 [541]	444.5 [17.5]	698.5 [27.5]
4CY4060C (115)	1050.93 [41-3/8]	82.1 [181]	46.3 [102]	43.1 [95]	76.7 [169]	306.9 [676]	248.6 [548]	401.3 [15.8]	711.2 [28.0]
4DCY4042C (090)	949.33 [37-3/8]	77.1 [170]	51.3 [113]	45.4 [100]	67.6 [149]	296.5 [653]	238.4 [525]	442.0 [17.4]	698.5 [27.5]
4DCY4048C (090)	949.33 [37-3/8]	78.9 [174]	53.0 [117]	47.2 [104]	69.4 [153]	306.6 [676]	248.5 [548]	442.0 [17.4]	698.5 [27.5]
4DCY4060C (115)	1050.93 [41-3/8]	83.9 [185]	47.2 [104]	43.1 [95]	76.7 [169]	306.9 [676]	248.8 [548]	398.8 [15.7]	711.2 [28.0]
4YCZ6048C (090)	1050.93 [41-3/8]	75.7 [167]	50.8 [112]	45.8 [101]	68.5 [151]	299.2 [659]	240.9 [531]	444.5 [17.5]	698.5 [27.5]
4YCZ6048C (115)		81.6 [180]	46.3 [102]	42.2 [93]	73.5 [162]	301.6 [665]	243.6 [537]	419.1 [16.5]	706.1 [27.8]
4YCZ6060C (115)	1050.93 [41-3/8]	82.1 [181]	46.3 [102]	43.1 [95]	76.7 [169]	306.9 [676]	248.6 [548]	401.3 [15.8]	711.2 [28.0]
4DCZ6048C (090)	1050.93 [41-3/8]	81.6 [180]	46.3 [102]	42.2 [93]	73.5 [162]	301.6 [665]	243.6 [537]	419.1 [16.5]	706.1 [27.8]
4DCZ6060C (115)	1050.93 [41-3/8]	83.9 [185]	47.2 [104]	43.1 [95]	75.7 [169]	306.9 [676]	248.8 [548]	398.8 [15.7]	711.2 [28.0]

Figure 6. 4YCZ6048 through 4YCZ6060 (3 of 3)

Installer's Guide

Step 3—Review Location and Recommendation Information

NOTE: The unit is shipped for horizontal installation.

NOTE: During heating operation, avoid supply air below 80 degrees F or return air below 50 degrees F to prevent flue gas condensation.

Horizontal Airflow Units

1. Location of the unit must allow service clearance around it to ensure adequate serviceability, maximum capacity, and peak operating efficiency.
2. These units are designed for outdoor installation. They may be installed directly on a slab, wood flooring, or on Class A, B, or C roof covering material. The discharge air from the condenser fans must be unrestricted for a minimum of 3 feet above the unit.
3. The louvers above and below the flue hood in the side panel must have adequate clearance around the air opening into the combustion area. See Figure 2 on page 5 or Figure 4 on page 7.
4. Examine all flue product-carrying areas of the furnace, its vent system, and the main burner for safe operation.

IMPORTANT: A minimum 0" clearance to combustible material shall be maintained on air outlet duct.

5. Exhaust vents or other sources of contaminated air must not be near the unit's air inlet if outside air is to be introduced as make-up air or a ventilation feature is to be used. Contamination from exhaust vents or chimneys may also foul the condenser causing degraded performance.
6. Check the handling facilities to ensure the safety of personnel and the unit(s).
7. The unit must be mounted level for proper drainage of water through the drain holes in the base pan.
8. The unit should not be exposed to direct roof water runoff.
9. Flexible duct connectors must be of a flame retardant material. All duct work outside of the structure must be insulated and weatherproofed in accordance with local codes.
10. Holes through exterior walls or roof must be sealed in accordance with local codes.
11. All fabricated outdoor ducts should be as short as possible.

Clearances

1. The recommended clearances for single-unit installations are illustrated in Figures 1 to 6, pages 4-9.
2. Any reduction of the unit clearances indicated in these figures may result in condenser coil starvation or the recirculation of warm condenser air. Actual clearances, which appear to be inadequate should be reviewed with a local engineer.
3. See the unit's nameplate for the absolute minimum clearance between the unit and any combustible surfaces.

Down Airflow Units

1. Location of the unit must allow service clearance around it to ensure adequate serviceability, maximum capacity, and peak operating efficiency.
2. Refer to the Installation section for instruction on converting the supply and return airflow covers to down airflow.
3. The field assembled Roof Mounting Curb (BAYCURB050A or BAYCURB051A) or a field fabricated curb should be in place before the unit is hoisted to the roof top.

The Roof Mounting Curb (frame) must be installed on a flat, level section of the roof (maximum of 1/4" per foot pitch) and provide a level mounting surface for the unit. Also, be sure to provide sufficient height above the roof to prevent water from entering the unit.

4. Be sure the mounting curb spans structural members (trusses) of the roof, thereby providing sufficient support for the weight of the unit, the curb, the duct(s), and any factory or field installed accessories.
5. The unit must be mounted level for proper drainage of water through the drain holes in the base pan.
6. Be sure the hole in the structure for the ducts is large enough to accommodate the fabricated ducts and the insulation surrounding them. Flexible duct connectors must be of a flame retardant material. All duct work outside of the structure must be insulated and weatherproofed in accordance with local codes.
7. Holes through exterior walls or roof must be sealed in accordance with local codes.
8. These units are designed for outdoor installation. They may be installed directly on a slab, wood flooring, or on Class A, B, or C roof covering material. The discharge air from the condenser fans must be unrestricted for a minimum of 3 feet above the unit.
9. The louvers above and below the flue hood in the side panel must have adequate clearance around the air opening into the combustion area.
10. Examine all flue product-carrying areas of the furnace, its vent system, and the main burner for safe operation.

IMPORTANT: A minimum 0" clearance to combustible material shall be maintained on air outlet duct.

11. Exhaust vents or other sources of contaminated air should not be near the unit's air inlet if outside air is to be introduced as make-up air or a ventilation feature is to be used. Contamination from exhaust vents or chimneys may also foul the condenser causing degraded performance.
12. Check the handling facilities to ensure the safety of personnel and the unit(s).

Clearances

1. The recommended clearances for single-unit installations are illustrated in Figures 1 to 6, pages 4-9.
2. Any reduction of the unit clearances indicated in these figures may result in condenser coil starvation or the recirculation of warm condenser air. Actual clearances, which appear to be inadequate should be reviewed with a local engineer.
3. See the unit's nameplate for the absolute minimum clearance between the unit and any combustible surfaces.

Step 4—Unit Installation

NOTE: The factory ships this unit for horizontal installation.

Install Flue Hood

1. Locate the Flue Hood in the literature package.
2. Remove the two Flue Hood mounting screws from the unit. They are located to the right of the Power Entry connection panel.
3. Attach the Flue Hood to the unit with the two screws removed in step 2. See Figure 2 on page 5 or Figure 5 on page 8 for correct orientation of the Flue Hood.

Ground Level Installation

To install the unit at ground level:

1. Place the unit on a pad the size of the unit or larger. The unit must be mounted level for proper drainage of water through the holes in the base pan. To securely attach the unit to the slab, use extreme mounting kit, BAYEXMK003A.

The pad must not come in contact with the structure (see Figure 7.) Be sure the outdoor portion of the supply and return air ducts are as short as possible.

Unit requires vibration support as indicated in Figure 7 below and in Figure 9 on page 13.

2. The louvers above and below the Flue Hood in the side panel must have adequate clearance around the air opening into the combustion area.
3. Location of the unit must allow service clearance around it. Clearance of the unit must be given careful consideration. See Figures 1 to 6, pages 4-9.

NOTE: Any reduction of the unit clearances indicated in these illustrations may result in condenser coil starvation or the recirculation of warm condenser air. Actual clearances, which appear to be inadequate should be reviewed with a local engineer.

IMPORTANT: A minimum 0" clearance to combustible material shall be maintained on air outlet duct.

4. Attach the supply and return air ducts to the unit as explained in the following Ductwork Installation section on page 16.
5. Flexible duct connectors must be of a flame retardant material. Insulate any ductwork outside of the structure with at least two (2) inches of insulation and weatherproof. There must be a weatherproof seal where the duct enters the structure.
6. Do not expose the unit to direct roof water runoff.
7. Seal all holes through exterior walls in accordance with local codes.
8. Continue with the following installation sections to complete the installation: Ductwork on page 16, Gas Piping on page 16, Filter on page 19, and Electrical Wiring on page 19.

Rooftop Installation -- Curb Mounting

Convert Horizontal Airflow to Down Airflow

The factory ships the unit for horizontal airflow. Perform this procedure to convert the unit to down airflow:

1. Remove the three (3) sheet metal screws securing the supply aircover and the four (4) sheet metal screws securing the return air cover from the base of the unit. Remove the covers from the base. See Figure 8, page 12.
2. Place the covers over the horizontal supply and return openings (painted side out). Align the screw holes, and secure using the same screws removed in step 1.

Install Full Perimeter Roof Mounting Curb

1. Verify that the roof mounting curb is correct for the unit. There are two curbs depending on the unit cabinet sizes:
 - 4YCZ6036 uses model BAYCURB050A.
 - 4YCZ6048 through 4YCZ6060 use model BAYCURB051A.
2. Assemble and install the curb following the instructions in the Installer's Guide included with the curb.

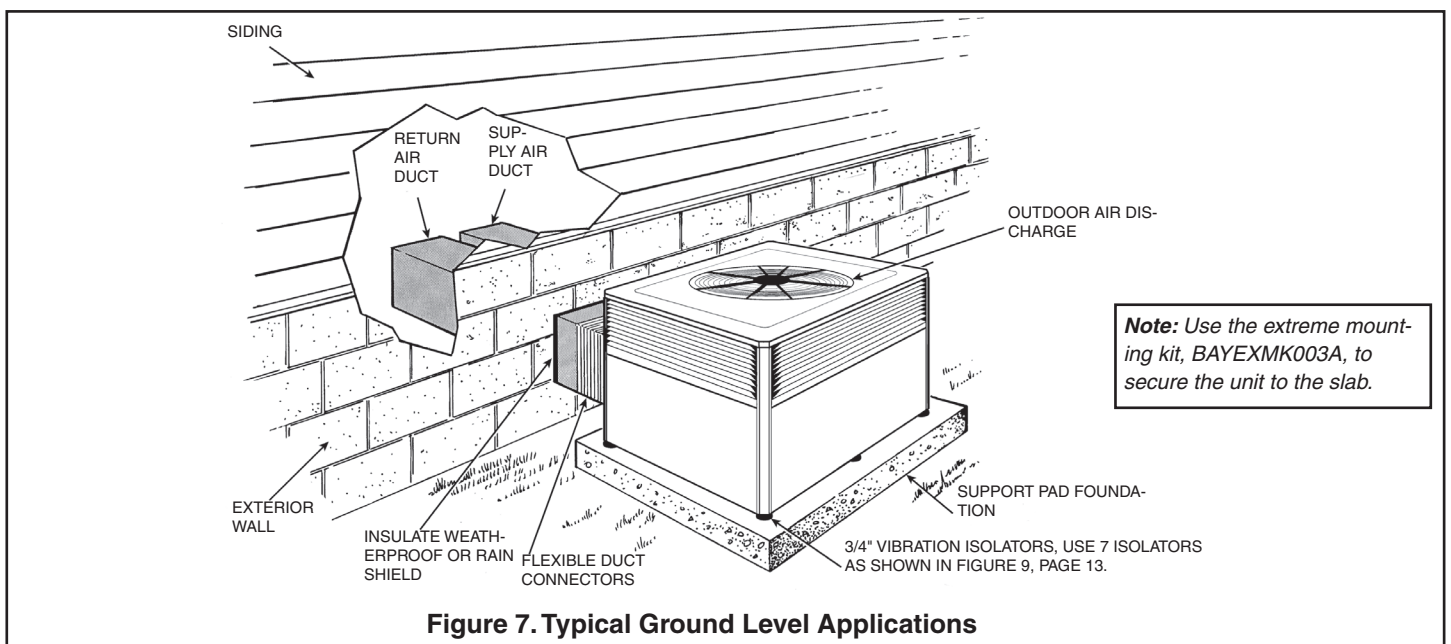

Figure 7. Typical Ground Level Applications

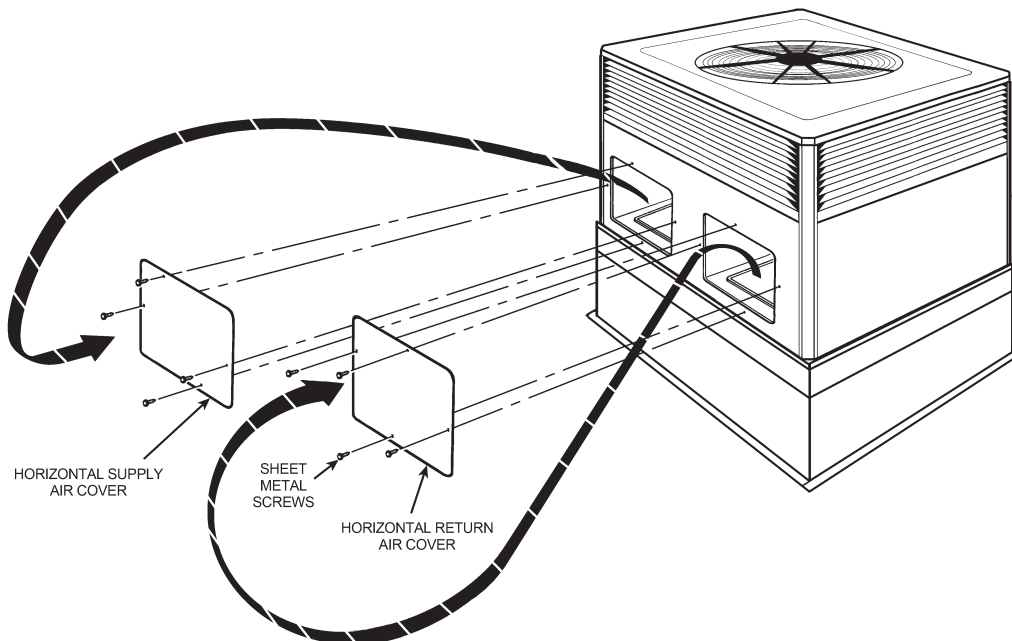

Figure 8. Converting Horizontal to Down Airflow

Lifting and Rigging

WARNING

Improper Unit Lift!

Test lift unit approximately 24 inches to verify proper center of gravity lift point. To avoid dropping of unit, reposition lifting point if unit is not level. Failure to properly lift unit could result in death or serious injury or possible equipment or property-only damage.

IMPORTANT: Do not lift the unit without test lifting for balance and rigging. Do not lift the unit in windy conditions or above personnel. Do not lift the unit by attaching clevis, hooks, pins, or bolts to the unit casing, casing hardware, corner lugs, angles, tabs, or flanges. Failure to observe these warnings may result in equipment damage.

1. Before preparing the unit for lifting, check the unit dimension drawings for center of gravity for lifting safety (Figures 1 to 6, page 4-9). Because of placement of internal components, the unit's weight may be unevenly distributed. Approximate unit weights are also provided in the unit drawings.

NOTE: When unit rigging and hoisting it is recommended that accessory kit BAYLIFT002B be used. It includes a kit of four (4) lifting lugs. See Figure 10 inset B, on page 14.

2. Insert the four lifting lugs in the openings provided in the drip lip on each end of the unit. See Figure 10 inset B on page 14. A tap or jerk to the lug will overcome the interference that arises due to the dimple on the lug.
3. When hoisting the unit, be sure that a proper method of rigging is used. Use either the unit's top shipping skid with straps or slings and spreader bars for protection during lifting. Always test-lift the unit to determine the exact unit balance and stability before hoisting it to the installation location.
4. When the curb and air ducts have been properly installed, the unit is ready to be hoisted to the roof and set in position.

IMPORTANT: To prevent damage to the sides and top of the unit when hoisting, retain the top shipping skid on the unit or use "spreader bars" as shown on page 14.

IMPORTANT: The unit must be lowered into position. The P.V.C. rubber tape on the curb flange permits the unit to be repositioned if required without destroying the P.V.C. rubber seal affixed to the mounting curb.

Placing the Unit on the Mounting Curb

1. The unit is designed with a perimeter drip lip that is lower than the unit base pan, see Figure 10, inset A, on page 14.
2. Position the unit drip lip down over and in contact with the outside corner of the curb, as illustrated in Figure 10, inset A, on page 14. Continue to lower the unit on top of the curb, with the unit drip lip astraddle, and in contact with, both the end and side rail of the curb. The unit should now rest on top of the curb. Use the extreme mounting kit, BAYEXMK001A, to add additional hold down strength to the mounting.

NOTE: The ductwork is installed as part of the curb installation. Do not attach ductwork to the unit and lower the unit with ductwork onto the curb.

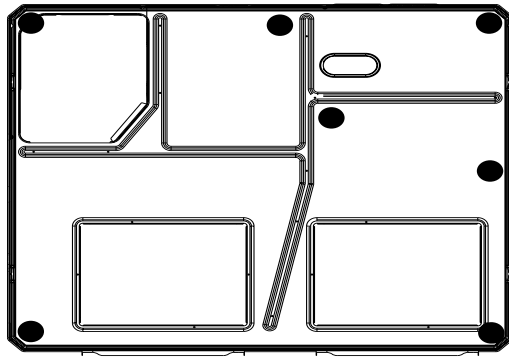

Small Cabinet
****018-036

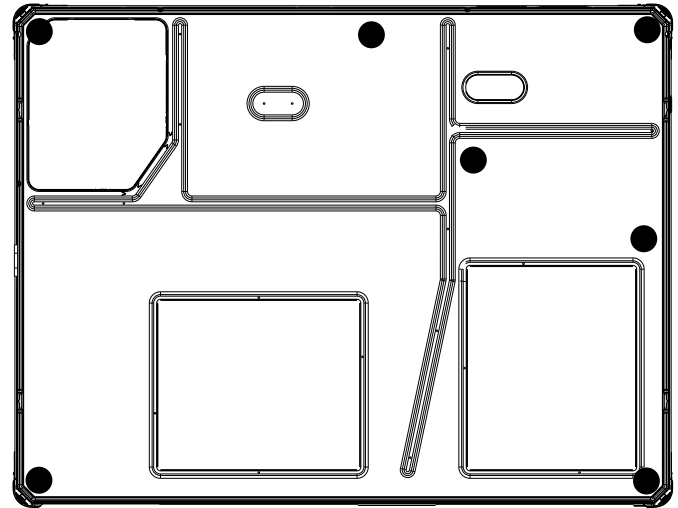

Medium Cabinet
****042-060

NOTE: These views represent the base as viewed looking up from underneath the unit.

IMPORTANT: Unit requires vibration isolator supports in the general areas shown. Locate 3/4" thick vibration isolators on the bottom of the basepan as illustrated by black dots for ground level pad applications. Modify vibration isolator location as necessary for frame and rail applications.

Figure 9. Vibration Isolators/Snow Feet Locations

Rooftop Installation -- Frame Mounting

For roof top applications using field fabricated frame and ducts, use the following procedure:

1. Locate and secure the frame to the roof by bolting or welding. Frame must provide adequate center support via a cross member centrally located channel rail. See Figures 12 and 13 on page 15. Vibration isolators should be installed as indicated in Figure 9, adjust as necessary for your frame. The isolators must be placed on base pan, not drip lip. Add flashing as required. Flashing must conform to local building codes.
2. Prepare the hole in the roof in advance of installing the unit.
3. Secure the horizontal or down airflow ducts to the roof. Refer to the previous Convert from Horizontal Airflow to Down Airflow section on page 11, if conversion is needed.
4. All fabricated outdoor ducts should be as short as possible.
5. Place the unit on the frame. Refer to Figures 12 or 13 on page 14.
6. The unit must be mounted level for proper drainage of water through the holes in the base pan.
7. Secure the unit to the frame.
8. Insulate any ductwork outside of the structure with at least two (2) inches of insulation and then weatherproof. There must be a weatherproof seal where the duct enters the structure.
9. The unit should not be exposed to direct roof water runoff.
10. Flexible duct connectors must be of a flame retardant material. All duct work outside of the structure must be insulated and weatherproofed in accordance with local codes.
11. Access and service clearances for the unit must be given careful consideration when locating the duct entrance openings. Figures 1 to 6, on pages 4-9, provide unit dimensions.
12. Continue with the following installation sections to complete the installation: Ductwork on page 16, Gas Piping on page 16, Filter on page 19, and Electrical Wiring on page 19.

Rooftop Installation -- Flat Roof - No Curb/Frame

For roof top applications using field fabricated ducts and sleeper rails rather than a curb or frame, use the following procedure:

1. Locate and secure the sleeper rails to the roof. Three (3) sleeper rails are required. One on each end to support the edges of the unit and one across the center of the unit. The center rail must run inside both drip lips. Vibration isolators should be installed as indicated on Figure 9, adjust as necessary for your sleeper rails. The isolators must be placed on base pan, not drip lip. Add flashing as required. Flashing must conform to local building codes.
2. Prepare the hole in the roof in advance of installing the unit.
3. Secure the horizontal or down airflow ducts to the roof. Refer to the previous Convert from Horizontal Airflow to Down Airflow section on page 11, if conversion is needed.
4. All fabricated outdoor ducts should be as short as possible.
5. Place the unit on the rails.
6. The unit must be mounted level for proper drainage of water through the holes in the base pan.
7. Secure the unit to the rails.
8. Insulate any ductwork outside of the structure with at least two (2) inches of insulation and then weatherproof. There must be a weatherproof seal where the duct enters the structure.
9. The unit should not be exposed to direct roof water runoff.
10. Flexible duct connectors must be of a flame retardant material. All duct work outside of the structure must be insulated and weatherproofed in accordance with local codes.
11. Access and service clearances for the unit must be given careful consideration when locating the duct entrance openings. Figures 1 to 6, on pages 4-9, provide unit dimensions.
12. Continue with the following installation sections to complete the installation: Ductwork on page 16, Gas Piping on page 16, Filter on page 19, and Electrical Wiring on page 19.

Installer's Guide

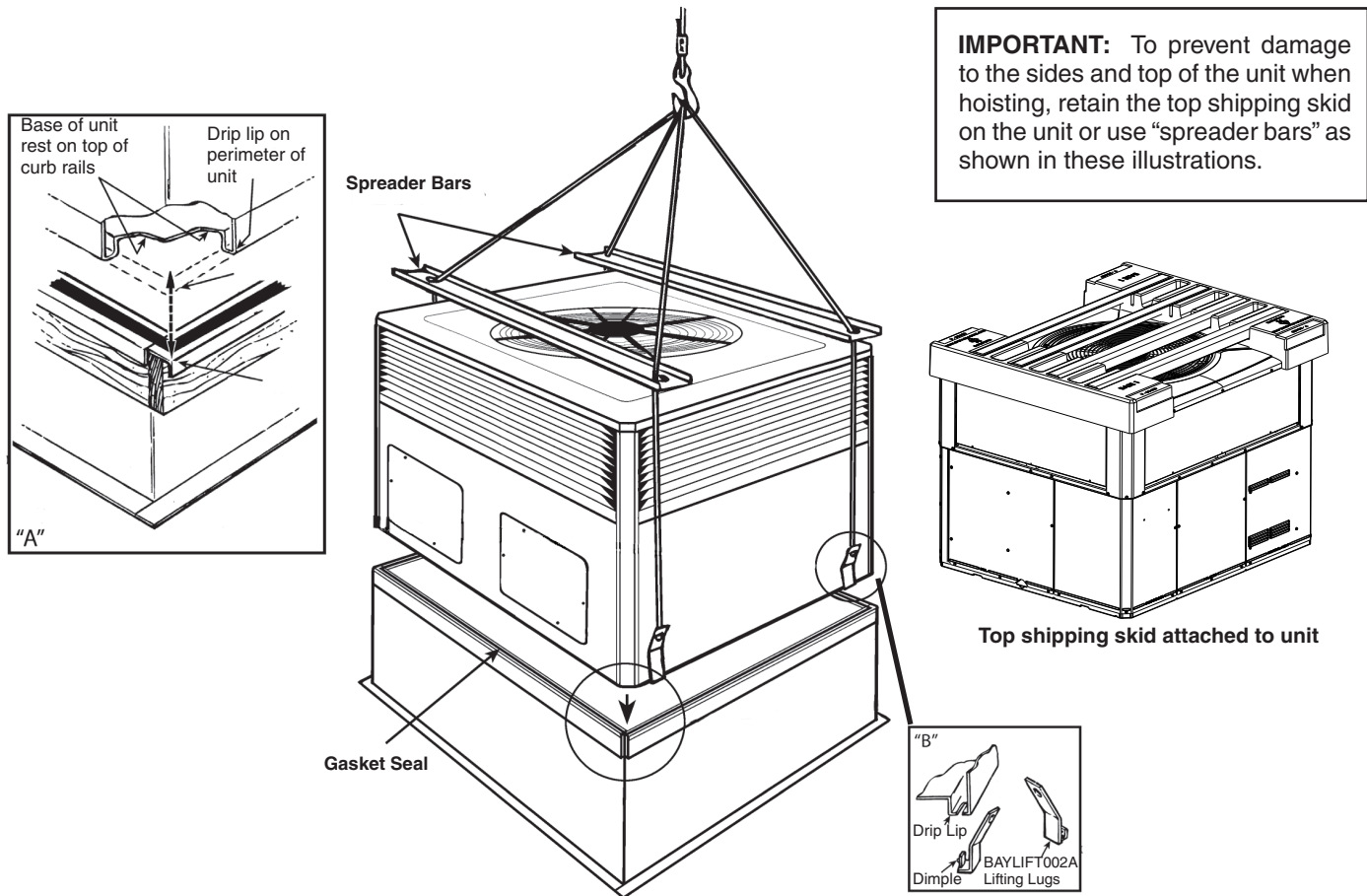
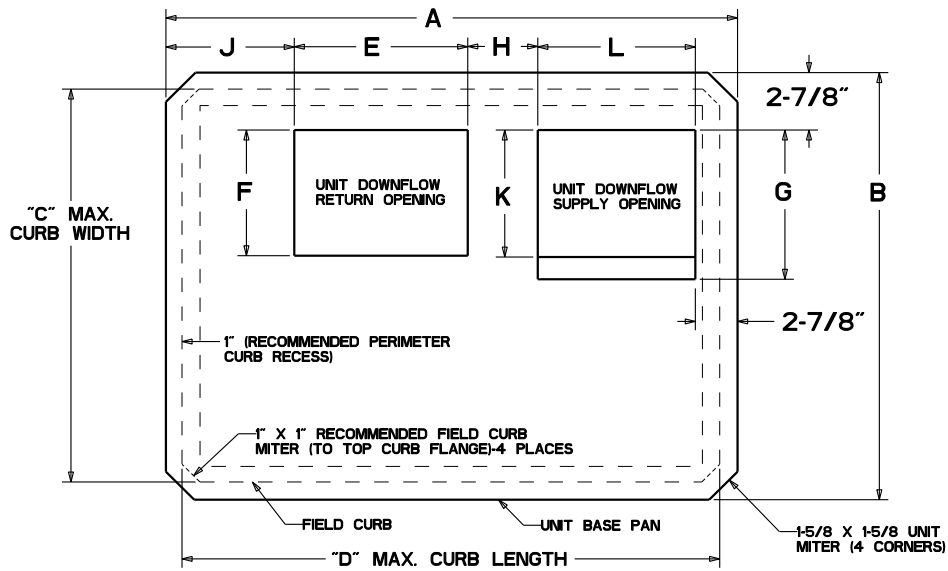

Figure 10. Lifting and Rigging



TOP VIEW OF UNIT BASE PAN WITH FIELD CURB BELOW
REFERENCE ILLUSTRATION FOR A CUSTOMER SUPPLIED ROOF CURB

PRINTED FROM D674152

MODEL	A	B	C	D	E	F	G	H	J	K	L
4 TC*, YC*, WC*, DC*018, 024, 030, 036	48-3/8	40-7/8	38-7/8	46-3/8	16	12	2-7/8	6-5/8	6-7/8	12	16
4 TC*, YC*, WC*, DC*042, 048, 060	58	43-7/8	41-7/8	56	18	15	2-7/8	9-5/8	12-1/2		15

This drawing was prepared by the manufacturer in order to provide detail regarding job layout only. This drawing is not intended to be used as a basis to construct, build or modify the item depicted in the drawing. The manufacturer is not responsible for the unauthorized use of this drawing and expressly disclaims any liability for damages resulting from such unauthorized use.

Figure 11. Curb Dimensions

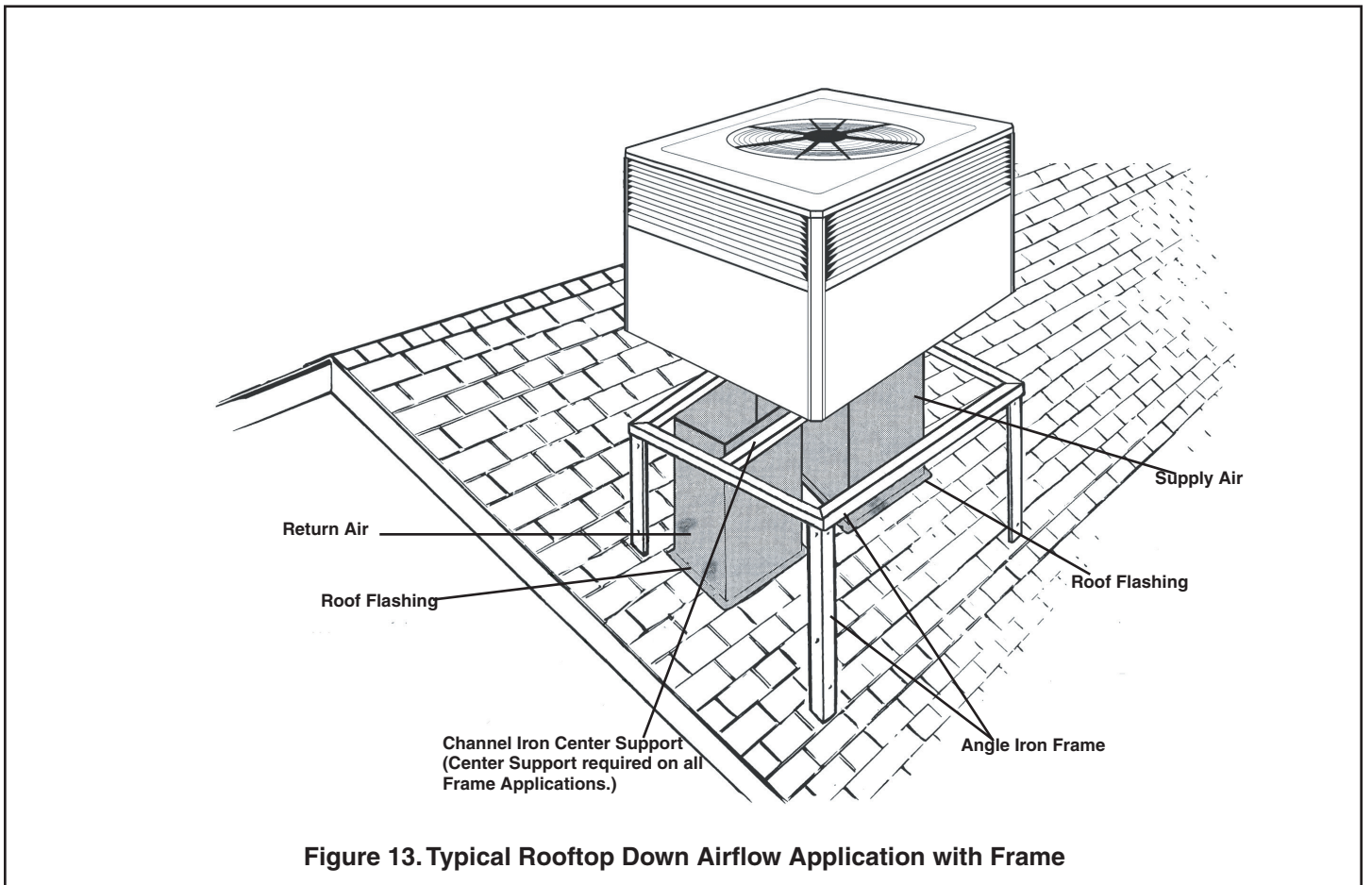
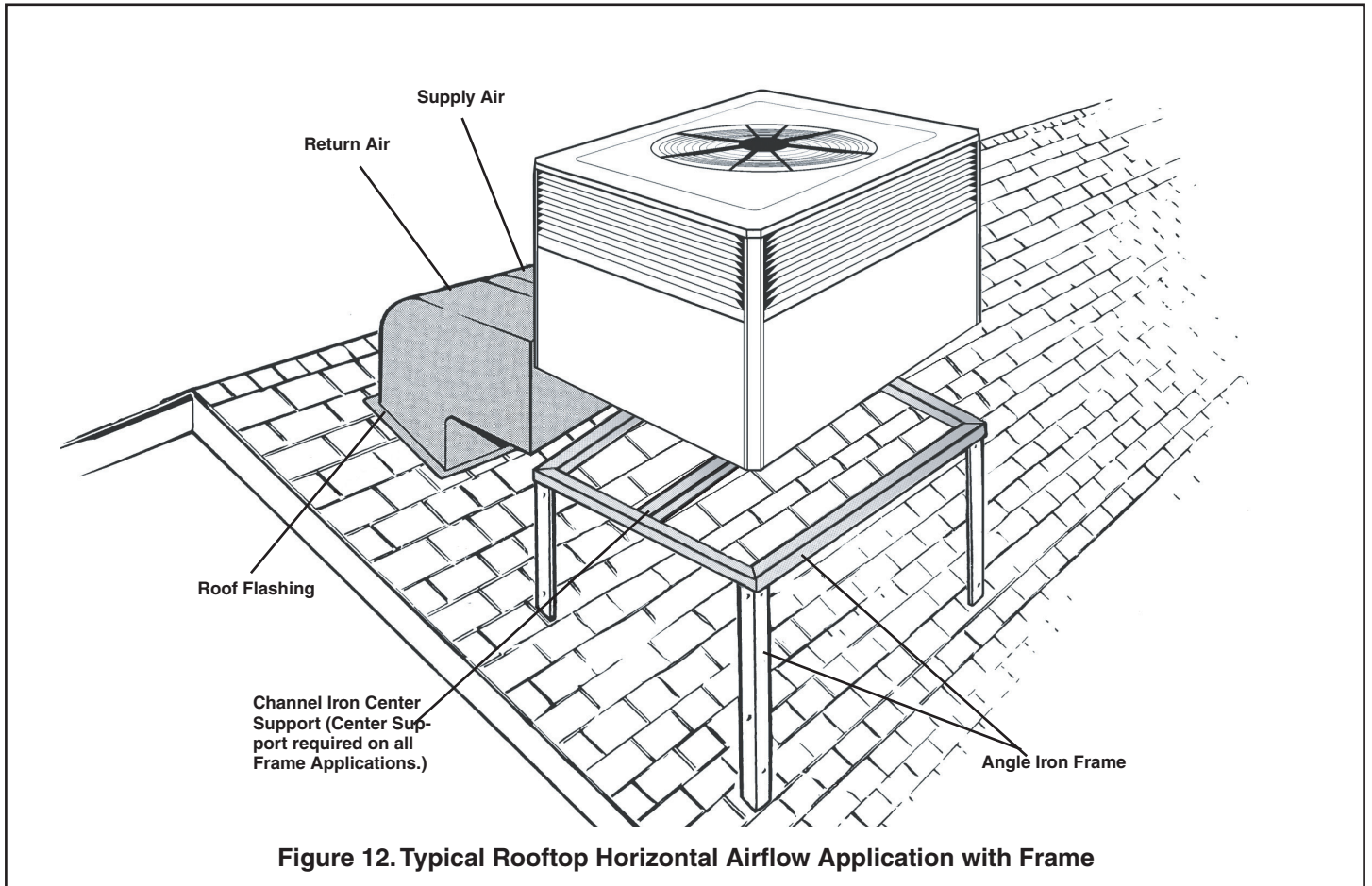

Installer's Guide

Ductwork Installation

Attaching Downflow Ductwork to Roof Curb

Supply and return air flanges are provided on the BAYCURB050 and BAYCURB051 model roof curbs for easy duct installation. All ductwork must be run and attached to the curb before the unit is set into place.

Attaching Downflow Ductwork to Roof Frame

Follow these guidelines for ductwork construction:

Connections to the unit should be made with three (3) inch canvas connectors to minimize noise and vibration transmission.

Elbows with turning vanes or splitters are recommended to minimize air noise and resistance.

The first elbow in the ductwork leaving the unit should be no closer than two (2) feet from the unit to minimize noise and resistance.

To prevent leaking, do not attach the ductwork to the bottom of the unit base; refer to the bottom example in Figure 14.

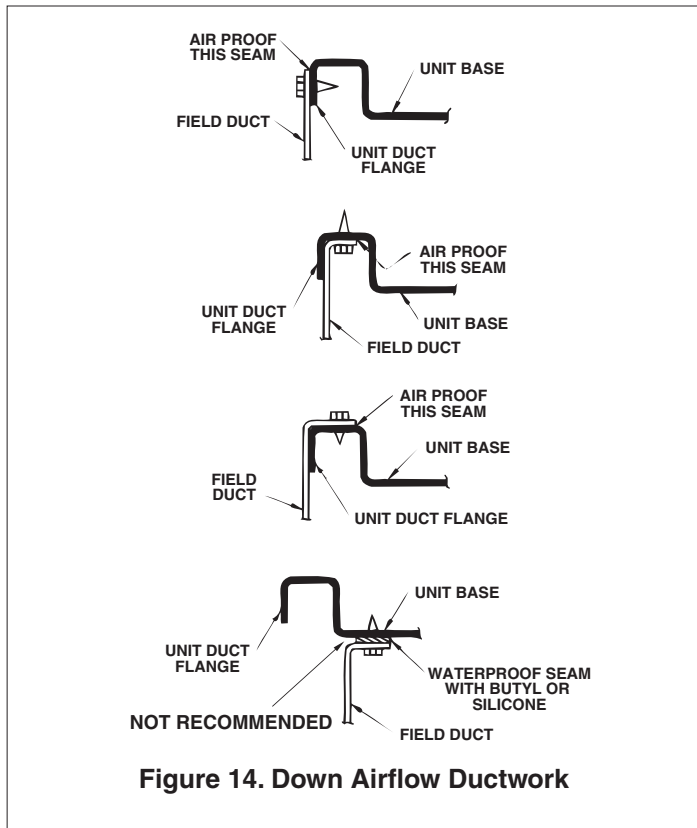

Attaching Horizontal Ductwork to Unit

All conditioned air ductwork should be insulated to minimize heating and cooling duct losses. Use a minimum of two (2) inches of insulation with a vapor barrier. The outside ductwork must be weatherproofed between the unit and the building.

When attaching ductwork to a horizontal unit, provide a flexible watertight connection to prevent noise transmission from the unit to the ducts. The flexible connection **must** be indoors and made out of heavy canvas.

NOTE: Do not draw the canvas taut between the solid ducts.

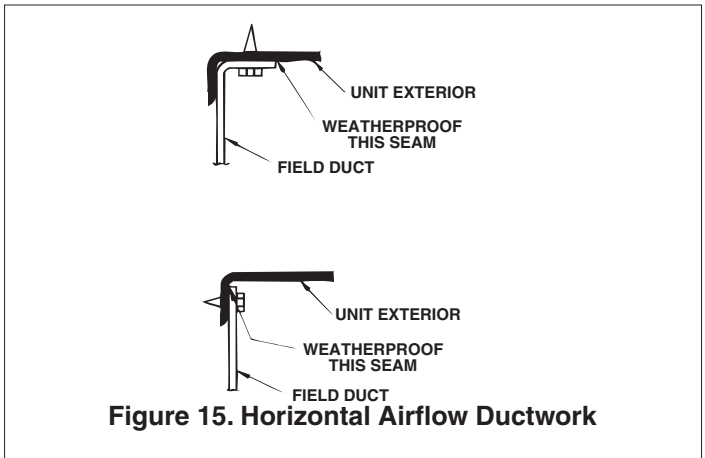

Condensate Drain Piping

A 3/4-inch female NPT condensate drain connection is provided on the filter access panel end of the unit. Provide a trap and fill it with water before starting the unit to avoid air from being drawn through. Follow local codes and standard piping practices when running the drain line. Pitch the line downward away from the unit. Avoid long horizontal runs. See Figure 16.

NOTE: Do not use reducing fittings in the drain lines.

The condensate drain must be:

- Made of 3/4" pipe.
- Pitched 1/4" per foot to provide free drainage to convenient drain system.
- Trapped.
- Must not be connected to a closed drain system unless the trap is properly vented.

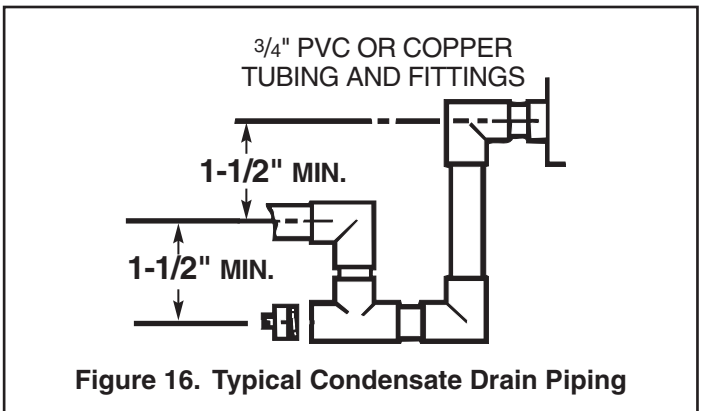

Gas Piping Installation

⚠ WARNING

FIRE OR EXPLOSION HAZARD!

Failure to follow the safety warning exactly could result in serious injury, death, or property damage. Never test for gas leaks with an open flame. Use a commercially available soap solution made specifically for the detection of leaks to check all connections. A fire or explosion may result causing property damage, personal injury or loss of life.

IMPORTANT: Before making the gas pipe connection give serious consideration to providing the clearance necessary to remove the access panels on the unit (e.g., economizer and filter access panels).

NOTE: In the absence of local codes, the installation must conform with American National Standard--Z223.1--National Fuel Gas Code, Latest Revision.

The available gas supply must agree with the required gas supply marked on the unit nameplate. Minimum permissible gas supply pressure for purpose of **input adjustment** must be at least 7.0 in. w. c. (inches water column) for natural gas and 11 in. w. c. for LP Gas.

Pipe Delivery Schedule

NOTE: The following procedure and tables apply to Natural Gas only.

1. Obtain from the gas company the heating value and specific gravity of the gas delivered.
2. Determine the exact length of pipe needed.
3. Read BTUH input nameplate on the furnace.
4. Use the multiplier opposite the specific gravity of the gas given in Table 1 below and insert in the following formula:
5. Using Table 2, select the pipe length nearest to calculated size.

$$CFH = \frac{\text{Furnace Input in BTUH}}{\text{Gas Heat Content in BTU/Cu. Ft. X Multiplier}}$$

6. Follow this line vertically down to the exact CFH found in Step 4 above or the next highest value.
7. Read horizontally to the left of this column for the required pipe size diameter.

Table 1. Specific Gravity Multiplier

	SPECIFIC GRAVITY	MULTIPLIER
MULTIPLIERS TO BE USED WHEN THE SPECIFIC GRAVITY OF THE GAS IS OTHER THAN 0.60	.50	1.10
	.55	1.04
	.60	1.00
	.65	.962

NOTE: If this is an LP Gas application, consult your LP Gas supplier for pipe sizes and deliveries.

Table 2. Natural Gas Only

TABLE OF CUBIC FEET PER HOUR OF GAS FOR VARIOUS PIPE SIZES AND LENGTHS							
PIPE SIZE (inch)	LENGTH OF PIPE (feet)						
	10	20	30	40	50	60	70
1/2	132	92	73	63	56	50	46
3/4	278	190	152	130	115	105	96
1	520	350	285	245	215	195	180
1-1/4	1050	730	590	520	440	400	370

THIS TABLE IS BASED ON PRESSURE DROP OF 0.3 INCH W.C. AND 0.6 SP.GR. GAS

Gas Pressure Set-up Precautions

IMPORTANT: Do not connect gas piping to the unit until a line pressure test has been completed. This unit should never be exposed to gas line pressure in excess of 14 inches water column (1/2 PSIG). The furnace and its equipment shutoff valve must be disconnected from the gas supply piping system during any pressure testing of that system at test pressures in excess of 1/2 psi.

The furnace must be isolated from the gas supply piping system by closing its individual manual shut-off valve during any pressure testing of the gas supply piping system at test pressures less than or equal to 1/2 psig (3.48 kPa).

Gas Supply Line Pressure

Before connecting the unit to the gas supply line, be sure to determine the gas pressure in the line.

If the gas supply pressure is excessive (above 14 inches water column or 1/2 psig), install a pressure regulator either at the supply source or in the branch circuit serving the unit. Once the regulator is installed, set it to provide a pressure of 7 inches water column with the unit operating and no greater than 14 inches water column with the unit not operating.

NOTE: Gas pressure in excess of 14 inches water column (1/2 psig) may damage the regulator, while improper regulation may result at pressures lower than 5.5 inches water column at the unit inlet.

If the supply line pressure is below the minimum supply pressure indicated on the unit nameplate, contact the gas supply company.

Follow these steps to complete the installation of the unit gas piping. See Figure 17.

NOTE: The shut-off gas cock must be installed outside of the unit and should meet the specifications of all applicable national and local codes.

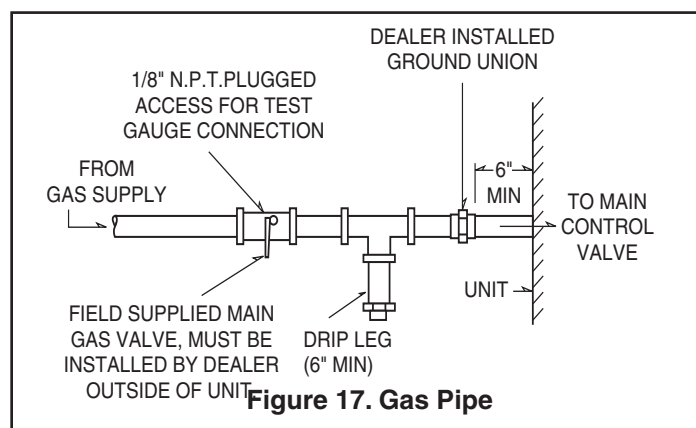

1. Install a tapped, Style A (1/8-inch NPT tap) shut-off gas cock at the end of the gas supply line near the unit. Be sure the tapped gas cock is downstream of the pressure regulator, if used.
2. Install a ground union joint downstream of the shut-off cock. This joint must also be installed outside of the unit.
3. Install a drip leg at least six (6) inches in depth next to the union as shown in Figure 17. This drip leg is required to collect any sediment that may be deposited in the line.

Installer's Guide

4. Before connecting the piping circuit to the unit, bleed the air from the supply line and then cap or plug the line and test the pressure at the tapped shut-off cock. The pressure reading should not exceed 14 inches water column.
5. Using an appropriate backup wrench on the gas valve inlet boss, connect the gas piping to the unit. Check the completed piping for leaks using a soap and water solution or the equivalent.
6. After installation of the gas pipe in the unit, the pipe opening should be closed with the filler/barrier plug provided.

- a. Attach a manifold pressure gauge.
- b. Remove the slot screw on top of the gas valve for 1st stage manifold pressure adjustment. Remove slot screw on outlet side for 2nd stage adjustment (See Figure 18).
- c. Turn the adjustment nut in to increase the gas flow rate, and out to decrease the gas flow rate using a 3/32" hex wrench.

Manifold Pressure

Check the manifold pressure at the unit gas valve. Do not exceed the recommended pressure shown on the unit nameplate.

Input Check and Adjustment

1. Make sure all gas appliances are off except the furnace.
2. Clock the gas meter with the furnace operating (determine the dial rating of the meter) for one revolution.
3. Match the "Sec" column in the gas flow (in cfh) Table 3, with the time clocked.
4. Read the "Flow" column opposite the number of seconds clocked.
5. Use the following factors if necessary.

$$\text{For 1 Cu. Ft. Dial Gas Flow CFH} = \frac{\text{Chart Flow Reading}}{2}$$

$$\text{For 1/2 Cu Ft. Dial Gas Flow CFH} = \frac{\text{Chart Flow Reading}}{4}$$

$$\text{For 5 Cu. Ft. Dial Gas Flow CFH} = \frac{10X \text{ Chart Flow Reading}}{4}$$

NOTE: For manifold pressures and orifice sizes for gas with other BTU ratings, contact the local gas utility. Manifold pressure should be 1.8 (low) to 3.5 (high) inches water column (+0.1). Input for natural gas must not exceed the value shown on the unit nameplate.

6. Multiply the final figure by the heating value of the gas obtained from the utility company and compare to the nameplate rating. This must not exceed the nameplate rating.
7. Changes can be made by adjusting the manifold pressure.

**Table 3. Gas Flow in Cubic Feet Per Hour
2 Cubic Foot Dial**

Sec.	Flow	Sec.	Flow	Sec.	Flow	Sec.	Flow
8	900	29	248	50	144	82	88
9	800	30	240	51	141	84	86
10	720	31	232	52	138	86	84
11	655	32	225	53	136	88	82
12	600	33	218	54	133	90	80
13	555	34	212	55	131	92	78
14	514	35	206	56	129	94	76
15	480	36	200	57	126	96	75
16	450	37	195	58	124	98	73
17	424	38	189	59	122	100	72
18	400	39	185	60	120	104	69
19	379	40	180	62	116	108	67
20	360	41	176	64	112	112	64
21	343	42	172	66	109	116	62
22	327	43	167	68	106	120	60
23	313	44	164	70	103	124	58
24	300	45	160	72	100	128	56
25	288	46	157	74	97	132	54
26	277	47	153	76	95	136	53
27	267	48	150	78	92	140	51
28	257	49	147	80	90	144	50

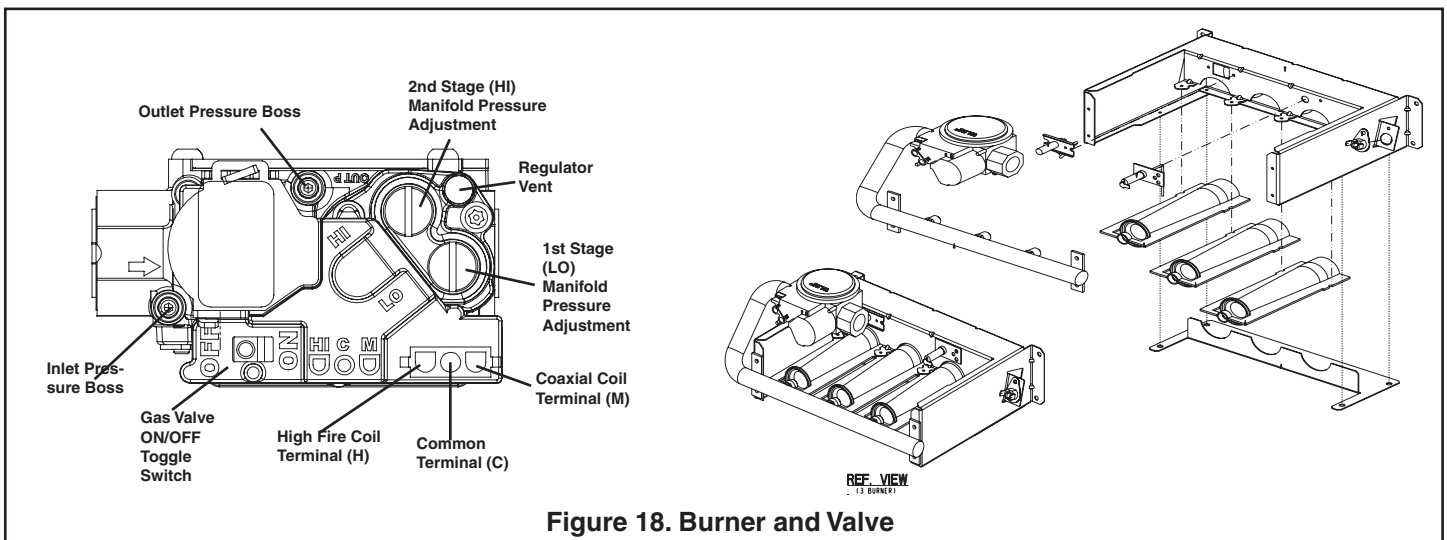

Figure 18. Burner and Valve

High Altitude Installation

Unit nameplate ratings are based on equipment operation from sea level to 2000 feet elevation above sea level. No orifice changes required for high altitude installation, please refer to below chart for rating information.

Table 4. High Altitude Derate Chart

HIGH ALTITUDE DERATE CHART NAT.							
Unit Input	Altitude (In Feet)						
115k	2001	3000	4000	5000	6000	7000	8000
High stage	112100	104100	96200	88100	86900	85600	85100
Low stage	84000	78100	72100	66100	65100	64200	63800
90k							
High stage	87700	81500	75200	69000	68000	67000	66500
Low stage	65700	61100	56400	51700	51000	50200	49900
70k							
High stage	68200	63300	58500	53600	52900	52100	51800
Low stage	51100	47600	43900	40200	39600	39100	38800
60k							
High stage	58500	54300	50100	46000	45300	44700	44300
Low stage	43800	40700	37600	34500	34000	33400	33200

Inputs shown are with factory orifices @ 3.5"WC (High Fire)
1.8"WC (Low Fire)
Natural Gas heating value of 950 btu/cuft.
For LP installations. Models that require #49 orifices, for altitudes from 7000 - 8000' orifices must be changed to #50.

Air Filter Installation

The packaged unit requires an air filter. The unit does not come with a factory installed filter rack in it, however, two filter frame accessories are offered that will allow the installation of a filter within the unit, BAYFLTR101 & BAYFLTR201. Otherwise a field supplied filter rack must be installed by the installer in the return duct work. Refer to Table 5 to determine filter sizes for field supplied filter racks.

Table 5. Filter Sizes (field supplied filter rack)

UNIT	NOMINAL CFM	FILTER* SIZE (Sq. Ft.)	FILTER RESISTANCE ("W.C.")
4YCZ6036	1200	4	0.08
4YCZ6048	1600	5.33	0.08
4YCZ6060	2000	6.67	0.08

*Filters must be installed in the return air system. The above square footages are based on 300 F.P.M. face velocity. If permanent filters are used, size per mfg. Recommendation with clear resistance of 0.05" W.C.

IMPORTANT: Air filters and media wheels or plates shall meet the test requirements in UL 900.

Electrical Wiring

⚠ WARNING

HAZARDOUS VOLTAGE, MOVING PARTS, AND GAS
Bodily injury can result from high voltage electrical components, fast moving fans, and combustible gas. For protection from these inherent hazards during installation and service, the electrical supply must be disconnected and the main gas valve must be turned off. If operating checks must be performed with the unit operating, it is the technician's responsibility to recognize these hazards and proceed safely.

NOTE: This unit is factory wired for 230V. See wiring diagram in SERVICE FACTS for 208V conversion.

Electrical Connections

Electrical wiring and grounding must be installed in accordance with local codes or, in the absence of local codes, with the National Electrical Code ANSI/NFPA 70, Latest Revision.

NOTE: For branch circuit wiring (main power supply to unit disconnect), determine wire size for the length of run using the circuit ampacity found on the unit nameplate and the N.E.C.

For more than 3 conductors in a raceway or cable, see the N.E.C. for derating the ampacity of each conductor.

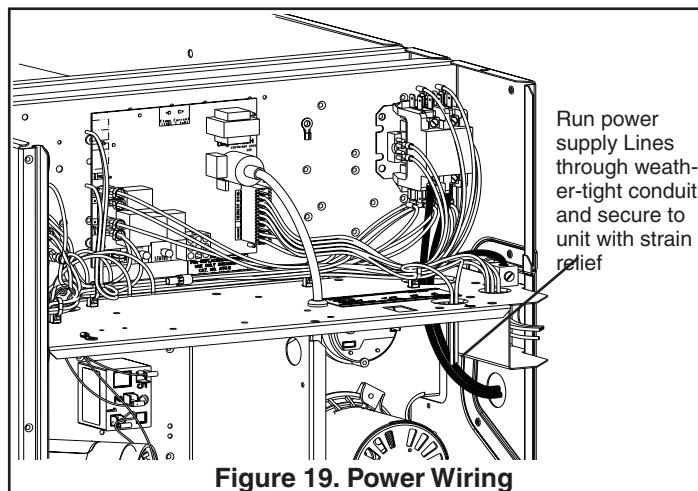

Figure 19. Power Wiring

Electrical Power

It is important that proper electrical power be available for the unit. Voltage variation should remain within the limits found on the unit nameplate.

Disconnect Switch

Provide an approved weatherproof disconnect within close proximity and **within sight of the unit**. If disconnect must be mounted to the cabinet, the location shown in Figure 21 should be the only one considered.

Over Current Protection

The branch circuit feeding the unit must be protected as shown on the unit nameplate.

Power Wiring

The power supply lines must be run in weather-tight conduit to the disconnect and into the side of the unit control box. Provide strain relief for all conduit with suitable connectors.

Provide flexible conduit supports whenever vibration transmission may cause a noise problem within the building structure.

1. Remove the CONTROL/HEAT access panel. Pass the power wires through the Power Entry hole in the end of the unit. See Figure 19.
2. Connect the high voltage wires to the appropriate contactor lug terminals. Single phase units use a two (2) pole contactor and three phase units use two (2) pole contactor and a Blue lead wire. Connect the ground to the ground lug on the chassis. See Figure 20. Be sure all connections are tight.

GROUNDING: THE UNIT MUST BE ELECTRICALLY GROUNDED IN ACCORDANCE WITH LOCAL CODES OR THE NATIONAL ELECTRIC CODE.

NOTE: Unit must be grounded for ignitor to operate properly. Gas pipe to unit is not an adequate ground. Ground the unit internally as provided.

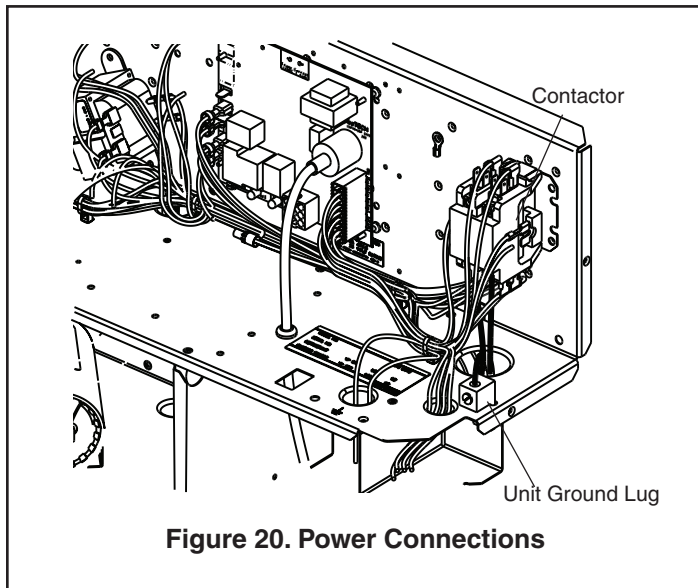

Figure 20. Power Connections

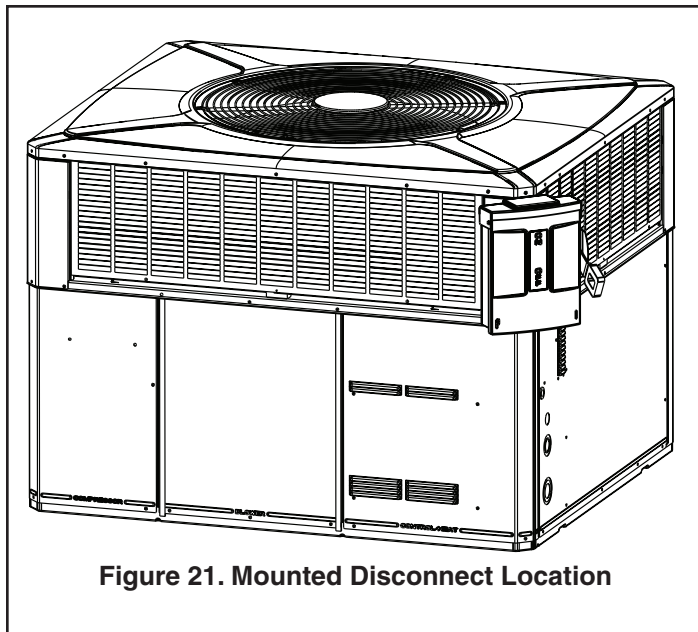

Figure 21. Mounted Disconnect Location

Control Wiring (Class II)

Low voltage control wiring should not be run in conduit with power wiring unless Class 1 wire of proper voltage rating is used. Route the thermostat cable or equivalent single leads of No. 18 AWG colored wire from the thermostat subbase terminals through the rubber grommet on the unit. See Figures 2 or 5 for the control entry (24V Entry) location. Make connections as shown on the unit wiring diagram.

Do not short thermostat wires since this will damage the control transformer.

Refer to Table 6 for recommended wire sizes and lengths for installing the unit thermostat. The total resistance of these low voltage wires must not exceed one (1) ohm. Any resistance in excess of 1 ohm may cause the control to malfunction because of the excessive voltage drop.

Table 6. Thermostat Wire Size and Maximum Length

Wire Size	Maximum Length
18	75
16	125
14	200

Thermostat Heat Anticipator

Set the heat anticipator of the thermostat to equal the amperage draw of the gas valve

IMPORTANT: Upon completion of wiring, check all electrical connections, including factory wiring within the unit.

Make sure all connections are tight. Replace and secure all electrical box covers and access panels before leaving the unit or turning on the power to the unit.

Step 5—Unit Startup

Pre-Start Quick Checklist

- Is the unit properly located and level with the proper clearance? See Figure 4.
- Is the duct work correctly sized, run, taped, insulated, and weatherproofed with proper unit arrangement? See Ductwork Installation section.
- Is the gas piping correctly sized, run, trapped, and purged of air? See Gas Piping section.
- Is the condensate line properly sized, run, trapped, and pitched?
- Is the filter of the correct size and number? Is it clean and in place?
- Is the wiring properly sized and run according to the unit wiring diagram?
- Are all the wiring connections, including those in the unit, tight?
- Has the unit been properly grounded and fused with the recommended fuse size? See Wiring Data.
- Is the thermostat level, correctly wired, well located, and set for the proper heat anticipation?
- Have the air conditioning systems been checked at the service ports for charge and leak tested if necessary?
- Does the condenser fan and indoor blower turn free without rubbing, and are they tight on the shafts?
- Has the indoor blower speed been determined and the proper speed been set? See the Unit Wiring Diagram.
- Has all work been done in accordance with applicable local and national codes?
- Are all covers and access panels in place to prevent air loss and safety hazards?

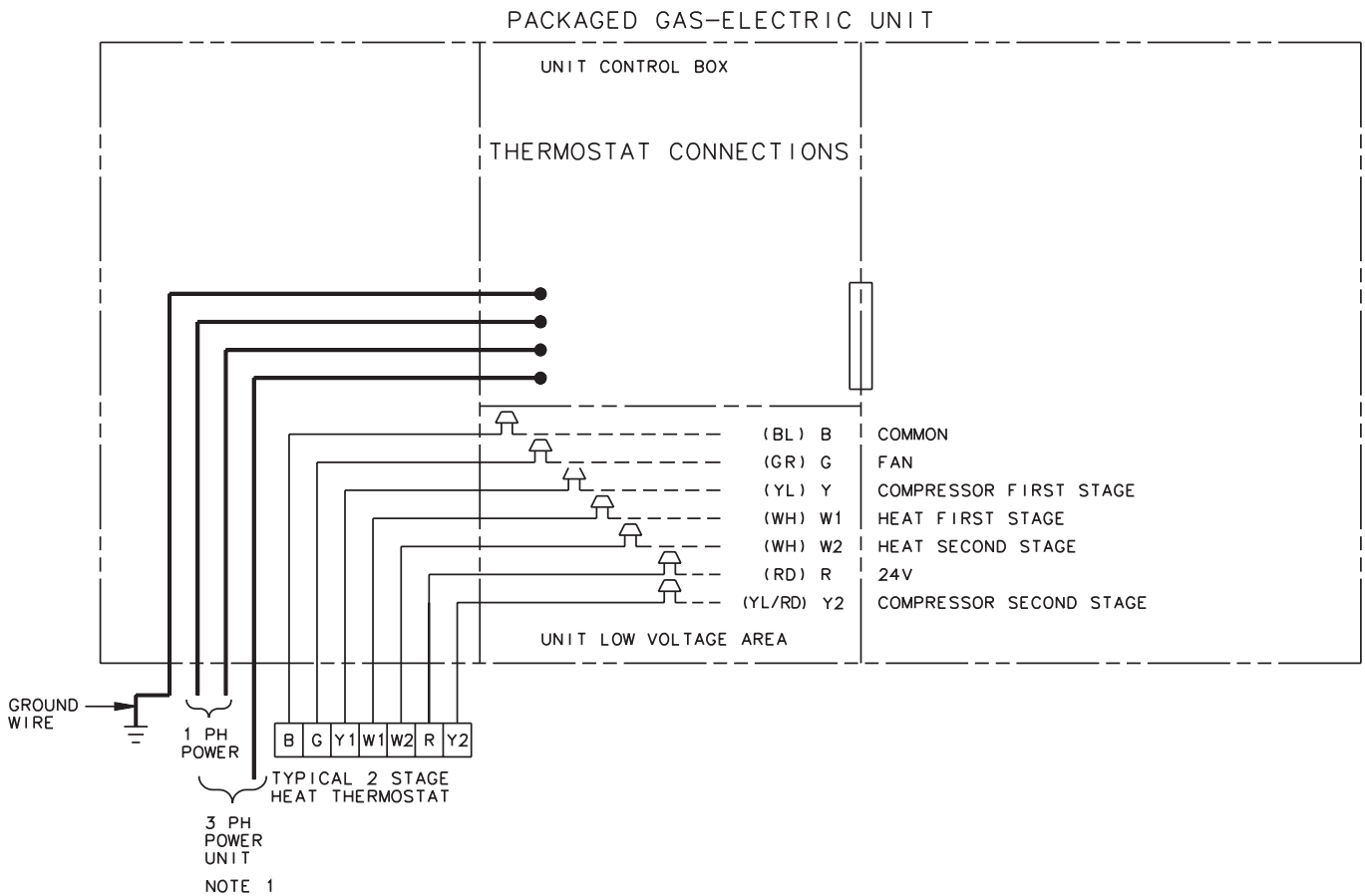

NOTES:

1. FUSED DISCONNECT SIZE, POWER WIRING AND GROUNDING OF EQUIPMENT MUST COMPLY WITH CODES.
2. BE SURE POWER SUPPLY AGREES WITH EQUIPMENT AND HEATER NAMEPLATE.
3. LOW VOLTAGE WIRING TO BE 18 AWG MINIMUM CONDUCTOR.
4. SEE UNIT DIAGRAM FOR ELECTRICAL CONNECTION DETAILS.
5. THE THERMOSTAT ON THE GAS/ELECTRIC UNIT MUST PROVIDE A 'G' SIGNAL IN THE COOLING MODE ONLY. DURING THE HEATING MODE THE FAN WILL BE ENERGIZED BY THE SYSTEM.
6. FOR SINGLE STAGE THERMOSTATS JUMPER W1 AND W2 TOGETHER. SECOND STAGE HEAT WILL BEGIN 10 MINUTES AFTER FIRST STAGE.

INTER-COMPONENT WIRING

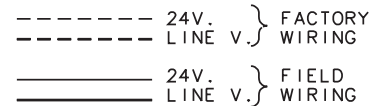

WIRE COLOR DESIGNATION			
ABBR	COLOR	ABBR	COLOR
BK	BLACK	PR	PURPLE
BL	BLUE	RD	RED
BR	BROWN	WH	WHITE
GR	GREEN	YL	YELLOW
OR	ORANGE		

NOTE: For economizer wiring instructions, see the Installer's Guide that came with your economizer.

Figure 22. 4YCZ6 Field Wiring Diagram

Installer's Guide

Starting the Unit in the Cooling Mode

To start the unit in the cooling mode, set the thermostat system switch to COOL and move the thermostat COOL indicator to a setting below room temperature. The condenser (outdoor) fan motor compressor and evaporator (indoor) fan motor will operate automatically.

NOTE: See the section on "Sequence of Operation" for a description of the cooling operating sequence.

Operating Pressures

After the unit has operated in the cooling mode for a short period of time, install pressure gauges on the gauge ports of the discharge and suction line valves. Check the suction and discharge pressures and compare them to the normal operating pressures provided in the unit's *SERVICE FACTS*.

NOTE: Do not use the pressures from the unit's *SERVICE FACTS* to determine the unit refrigerant charge. The correct charge is shown on the unit nameplate. To charge the system accurately, weigh in the charge according to the unit nameplate.

Voltage

With the compressor operating, check the line voltage at the unit. The voltage should be within the range shown on the unit nameplate. If low voltage is encountered, check the size and length of the supply line from the main disconnect to the unit. The line may be undersized for the length of the run.

Cooling Shut Down

Set the system mode to OFF or adjust the cooling setpoint to above room temperature.

Heating Cycle

These units are equipped with a solid-state ignition control that lights the burners each time the thermostat calls for heat. The burners are extinguished during the OFF cycle.

The gas heating section of the unit can be started using the following procedure:

1. Be sure the thermostat is at its lowest setting and the power to the unit is off.
 - a. Turn the main shutoff valve on the gas supply line ON.
 - b. Turn or switch the manual valve on the combination gas valve ON position.
2. Be sure the burner compartment access panel is in place.
 - a. Turn on the electrical power to the unit.
 - b. Turn the thermostat to the highest setting in the heating cycle.
3. As the thermostat calls for heat, the system cycles as follows:
 - a. The combustion blower is energized.
 - b. The pressure switch is closed.
 - c. The gas valve opens and the ignitor lights the burner.
 - d. Cycle the thermostat on and off a few times to check out the control system and burner operation characteristics.
4. With the burners operating, check the manifold pressure with a manometer. Do not exceed recommended pressures.
5. Adjust the unit to obtain an air temperature rise within the range that is specified on the unit nameplate.

NOTE: For manifold pressures and orifice sizes for gas with other BTU ratings, contact the local gas utility. Manifold pressure should be 1.8 (low) to 3.5 (high) inches water column (+0.1). Input must **not** exceed the value shown on the unit nameplate.

6. Set the heat anticipator of the thermostat to equal the amperage draw of the gas valve, approximately 0.7.
7. Set the thermostat at the desired temperature setting and the unit will function automatically.

Starting the Unit in the Gas Heating Mode

1. Check to make sure all grilles and registers are open and all unit access doors are closed before start-up.
2. Purge the gas supply line of air by opening the union ahead of the unit. When the odor of gas is detected, retighten the union and wait five (5) minutes before proceeding.
3. Set the wall thermostat to its lowest position and place the fan switch in the AUTO or ON position.
4. Open the main gas valve(s) and turn on the unit power supply.
5. Reset the heating temperature lever on the room thermostat at the highest value above room temperature. The combustion blower motor should energize. The main burners should light within 20-25 seconds. Initial start may be delayed somewhat if the unit has not been purged and air is trapped in the gas line.

NOTE: Blue smoke produced by the heat exchanger during the initial burner firing is caused by a thin film of oil on the surface of the heat exchanger. This oil will burn off quickly.

Final Installation Checklist

- Does the unit run and operate as described in the section on Sequence of Operation in response to the room thermostat?
- Are the condenser fan and indoor blower operating correctly with proper rotation and without undue noise?
- Is the compressor operating correctly and has the system been checked with a charging chart?
- Has the voltage and running current been checked to determine if it is within limits?
- Has the thermostat been checked for calibration and the air discharge grilles adjusted to balance the system?
- Has the ductwork been checked for air leaks and condensation?
- Has the furnace manifold pressure been checked and adjusted if necessary?
- Has the heating air temperature rise been checked?
- Has the unit been checked for tubing and sheet metal rattles? Are there any other unusual noises to be checked?
- Are all covers and panels in place and properly fastened?
- Has the owner been instructed on the proper operation and maintenance of the unit? Be sure to leave this manual with the owner.

Sequence of Operation

Operation of the unit heating and cooling cycles is automatic when the system is set to **HEAT** or **COOL** (the optional automatic change-over thermostat, when set to **AUTO**, automatically changes to heat or cool with an appropriate room temperature change). The fan can be set to **ON**, causing continuous evaporator (indoor) fan operation or set to **AUTO** causing fan operation to coincide with heating or cooling run cycles. Continuous fan mode during cooling operation may not be appropriate in humid climates. If the indoor air exceeds 60% relative humidity or simply feels uncomfortably humid, it is recommended that the fan only be used in the **AUTO** mode. The fan switch **ON** position provides continuous operation while the **AUTO** position provides operation during the heating or cooling cycles.

Heating Cycle

Thermostat call for heat (2-stage thermostat)

Call for 1st stage only:

(R) and (W1) thermostat contacts close signaling the control module (IGN) to run its self-check routine. After the control has verified that the pressure switch (PS) contacts are open, the limit switch (TCO) contacts are closed, and the flame rollout (FL) switch is closed, the induced draft blower (CBM) will be energized on high speed for approximately 5 seconds.

After the induced draft blower (CBM) has come up to speed, the control will verify that the pressure switch (PS) contacts are closed and switch the induced draft blower to low speed for 20 second prepurge. The gas valve (GV) is energized in the first stage to permit gas flow and the spark igniter (IP) is energized. The flame detector (FD) confirms that ignition has been achieved within the 7 second trial period.

As the flame detector confirms that ignition has been achieved the delay to indoor fan on period begins timing and after approximately 45 seconds, the indoor blower motor (IDM) will be energized at low speed and will continue to run during the heating cycle.

Call for 2nd stage after 1st stage:

(R) and (W2) thermostat contacts close signaling a call for second stage heat. The induced draft motor (CBM) is energized on high speed and the gas valve on second stage. After approximately 30 seconds the control energizes the indoor blower on high speed.

2nd stage satisfied, 1st stage still called:

(R) and (W2) opens, the induced draft blower is reduced to low speed the gas valve is reduced to first stage. After about 30 seconds the indoor blower motor is reduced to low speed.

1st stage satisfied:

(R) and (W1) opens, the gas valve (GV) will close. The induced draft blower (CBM) will be de-energized after approximately 5 seconds postpurge. The indoor blower motor (IDM) will continue to run for the fan off period (field selectable 60 or 90 seconds [by jumpers]), then will be de-energized by the control module.

Thermostat call for heat (1-stage Thermostat)

(R) and (W1/W2) (jumped) thermostat contacts close signaling a call for heat. 1st stage sequence of operation remains the same as above. 2nd stage heat has a 10 minute delay from the time of 1st stage ignition.

Thermostat satisfied:

(R) and (W1/W2) (jumped) contacts open signaling the control module to close the gas valve and de-energize the induced draft blower after approximately 5 second postpurge. The indoor blower motor will continue to operate at the current speed for 60 or 90 seconds after the flames are extinguished.

Safety Sequences

This product is equipped with safety devices to protect against abnormal conditions.

The temperature limit switch (TCO) is located on the blower barrier, and can be accessed through the blower compartment. This automatic reset device protects against excessive supply air temperature. If this device opens, the gas valve is immediately closed and will not permit operation until the limit switch closes.

The rollout switch (RO) is located in the gas compartment near the inlet of the burners. This is a manual reset device designed to protect against any form of flame rollout. If this device is opened the gas valve is immediately de-energized and the control (IGN) will lockout the system. The rollout switch (RO) must be reset before operation is allowed to continue.

The pressure switch (PS) is located in the upper right side of the gas compartment. This automatic device assures adequate combustion air pressure. If pressure against the induced draft blower outlet becomes excessive, the pressure switch will react and shut off the gas valve, until acceptable combustion pressure is again available.

If the control (IGN) does not sense flame within the first trial for ignition period, the gas valve will be de-energized. The control (IGN) will initiate a 60-second interpurge. Following the interpurge, the control will perform a second ignition attempt. If the second try is not successful, the control will start another 60-second interpurge. After the interpurge, a third attempt will be tried. If the third try is not successful, the control will lock out.

If loss of flame occurs during a heating cycle, the control (IGN) will close the gas valve and cycle through the ignition trial as stated above.

If control lock out occurs, the control (IGN) will retry a complete ignition sequence in 1 hour.

The control (IGN) can be reset by removing power to the unit or by turning the thermostat from **ON** to **OFF** for approximately three seconds, then back **ON**.

Cooling Cycle

Thermostat call for cooling (2-stage thermostat)

Call for 1st stage cooling only:

With the room thermostat set to the **COOL** position and the fan switch in the **AUTO** position, a call for cooling will supply power to the unit from the room thermostat (Y1) and (G) terminal. (Y1) provides power to the compressor contactor (CC). The energized compressor contactor (CC) completes the circuit to the compressor for 1st stage (Low) operation and the outdoor single speed fan motor (ODM). (G) provides power to the (ECMC) for low speed (IDM) indoor fan motor operation.

The thermostat will continue to cycle the compressor and fans to maintain the desired temperature.

Call for 2nd stage after 1st stage

On a call for 2nd stage cooling, power is supplied from the room thermostat (Y2) terminal to the compressor rectifier (ACR) and the (ECMC). This energizes the (ACR) switching the compressor to 2nd stage (High) operation. With the compressor's internal solenoid energized, both unloading orifices are closed enabling the compressor to pump at full rated capacity. The (ECMC) is energized for indoor fan motor (ECM) high speed fan operation. The room thermostat will continue to cycle the system between 1st and 2nd stage to maintain the desired temperature without any cycling time delays in operation.

Installer's Guide

ECM Fan Motor Adjustments

If the airflow needs to be increased or decreased, see the Airflow Table in the SERVICE FACTS. Information on changing the speed of the blower motor is in the Blower Performance Table. Blower speed changes are made on the ECM Fan Control mounted in the control box. The ECM Fan Control controls the variable speed motor. There is a bank of 8 dip switches, (See Figure 20 below), located on the board. The dip switches work in pairs to match the cooling/heat airflow (CFM/TON), Fan off-delay options and electric heat airflow adjustment. The unit ships with dip switches defaulted as shown below.

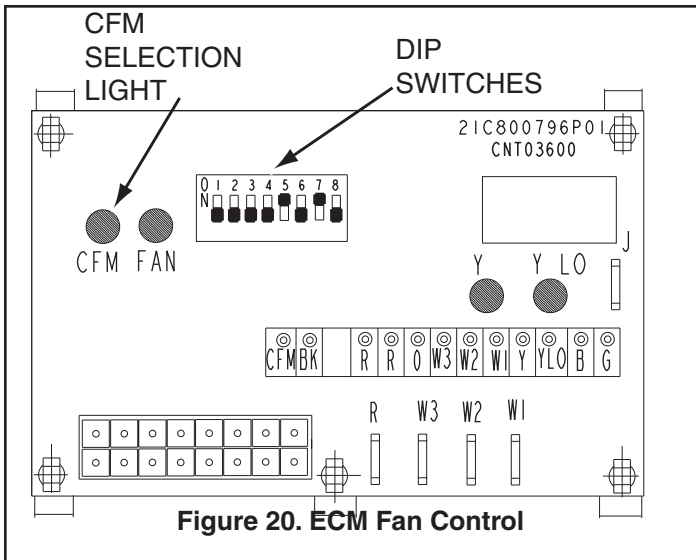

Maintenance

Owner Maintenance

⚠ WARNING

EXPLOSION HAZARD!

To prevent an explosion or possible injury, death, and equipment damage. Do not store combustible materials, gasoline, or other flammable vapors or liquids near the unit.

Some of the periodic maintenance functions of the 4Y CZ6 unit can be performed by the owner; this includes replacing the disposable or cleaning the permanent air filters, cleaning the unit cabinet, and conducting a general unit inspection on a regular basis.

Filters

When the system is in constant operation, inspect the filters at least once each month.

If you have disposable-type filters, replace them with new filters of the same type and size. **Do not attempt to clean disposable filters.**

Permanent-type filters can be cleaned by washing them with a mild detergent and water. Make sure that the filters are thoroughly dry before reinstalling them in the unit (or duct system).

NOTE: It may be necessary to replace permanent filters annually if washing fails to clean the filter or if the filter shows signs of deterioration. Be sure to use the same type and size as was originally installed.

Condenser Coil

Be sure to keep all vegetation and debris away from the condenser coil area.

Service Maintenance

Service maintenance should be performed by qualified service personnel.

Cooling Season

To keep the unit operating safely and efficiently, the manufacturer recommends that a qualified service technician check the entire system at least once each season or more often if needed. The service technician should examine these areas of the 4YCZ6 unit:

- filters (for cleaning or replacement)
- motors and drive system components (for proper operation)
- economizer gaskets (for possible replacement)
- safety controls (for mechanical cleaning)
- electrical components and wiring (for possible replacement and connection tightness)
- condensate drain (for proper sealing and cleaning)
- unit duct connections (to see that they are physically sound and sealed to the unit casing)
- unit mounting support (for structural integrity)
- the unit (for obvious unit deterioration)

Heating Season

Complete the following unit inspections and service routines described at the beginning of each heating season.

- Visually inspect the unit to ensure that the airflow required for combustion and condenser coil is not obstructed from the unit.
- Inspect the control panel wiring to verify that all electrical connections are tight and that the wire insulation is intact.
- Check the operation of the gas ignition system as follows: Turn off the gas supply with the unit operating to verify that the gas valve closes and that a re-ignition cycle is initiated by the unit.
- Visually inspect the inside of the burners and the burner ports for deposit buildup and corrosion. Wipe and brush the inside of the burner and the burner ports and then clean with a dry cloth. If the deposit buildup or corrosion is excessive, replace the burners.

Manifold Pressure Check and Adjust

1. Connect a manometer to the pressure tap at the outlet side of the unit's gas valve (remove the Control/Heat access panel). Read the manifold pressure with the burners firing. See Figure 16 on page 17 for gas valve connections.
2. If the manifold pressure reading does not match the value indicated on the unit's nameplate, the unit's pressure regulator must be adjusted as follows:
 - a. Remove the cover screw on the gas regulator located on the front side of the unit's gas valve.
 - b. Turn the adjusting screw clockwise to increase manifold pressure or counterclockwise to decrease manifold pressure.
3. Check the temperature rise during furnace operation to insure that it falls within the range specified on the unit's nameplate.
4. If the temperature rise noted is outside of the specified limits, adjust the indoor air flow to cause the temperature rise of the heat exchanger to fall within the required range.

Flue Hood and Combustion Blower Cleaning

CAUTION

Never use combustible cleaning fluids on any part of the furnace.

Before each heating season, the Flue Hood and combustion blower should be inspected for signs of any blockage or soot-ing. **Any cleaning required should be performed only by a qualified service technician** using the following procedure:

1. Turn the comfort control to OFF. Turn off power to the unit. Turn the main power disconnect OFF. Turn the manual gas valve OFF.
2. Remove the Flue Hood from the side panel.
3. Remove the combustion blower from the vestibule panel. Disconnect blower wiring and pressure switch hose.
4. Wipe blower and Flue Hood clean with a dry cloth.
5. Replace the combustion blower gasket with a new one.
6. Reassemble combustion blower and Flue Hood in reverse order of removal. Reconnect pressure switch hose.
7. Verify all wiring is correct per the unit's wiring diagram.
8. Follow start-up procedure to place unit back in service. Verify proper operation.

Installer's Guide

Status LEDs

IGN Board Diagnostic Codes

There are two LEDs on the IGN board that provide status and diagnostic information. Refer to Table 8 for a description of the LED codes.

Table 8. IGN LED Diagnostic Indicators *

IGN Diagnostic Indicators Flash Codes			
Status LED		Liteport LED	
Steady OFF	Check Power or Failed Board	2 Flashes	System Lockout: Failed to detect or sustain flame
Slow Flash Rate	Normal, No Call for Heat	3 Flashes	Pressure switch problem detected
Fast Flash Rate	Not used	4 Flashes	High Limit switch protection device open
Steady ON	Normal, No Call for Heat	5 Flashes	Flame sensed and gas valve <u>not</u> energized or flame sensed and no "W" signal
		6 Flashes	Flame Rollout Switch open
		7 Flashes	Thermostat miswired; W1 & W2
Fast Flash Rate: The LED will flash on for 1/4 second, and off for 1/4 second			
Slow Flash Rate: The LED will flash on for 3/4 second, then off for 1/4 second.			
The pause between groups of fast flashes is 3 seconds.			

