

Product Data

4YCZ6024 through 4YCZ6060

**Packaged Convertible Gas/Electric
16 SEER**

2 - 5 Ton, 60 - 120 MBTU

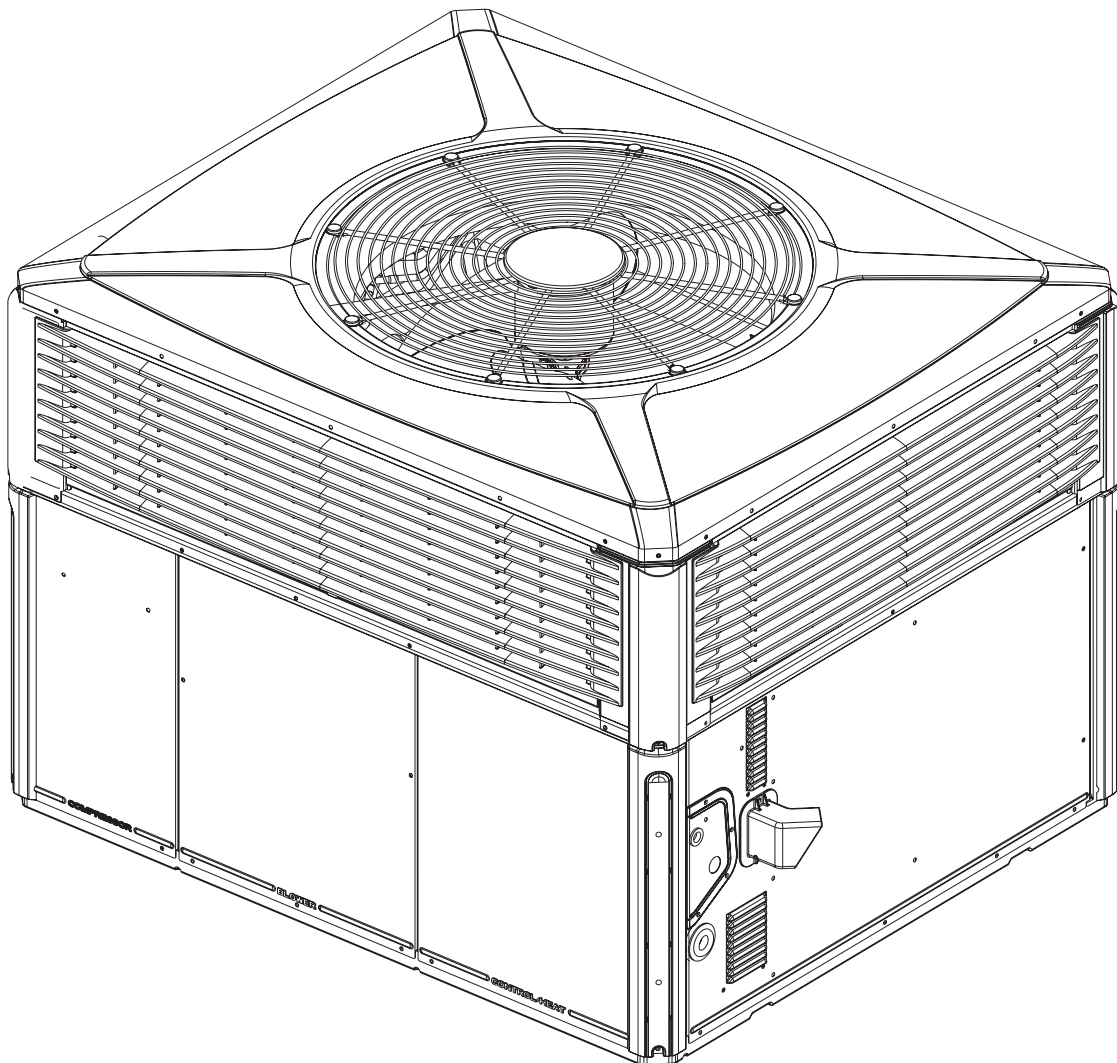

Packaged Convertible Gas/Electric System

American Standard Heating & Air Conditioning offers a complete family of packaged gas/electric heating and cooling systems, designed to give you the unbeatable combination of energy efficiency and lower operating costs. In warm weather, the packaged gas/electric system functions as an all-electric, high efficiency air conditioner. In cold weather, it operates as a natural gas or propane gas furnace, offering you the best of both energy worlds.

Introducing the new AMERICAN STANDARD Heating & Air Conditioning Packaged Convertible Gas/Electric System.

Single Packaged Convertible Gas/Electric Systems are easy and versatile to install. Because cooling and heating functions are all contained in a single cabinet, a American Standard Heating & Air Conditioning single packaged convertible gas/electric system is easy to install and service. It can be flush mounted beside your home at ground level or placed on the roof for horizontal or downflow installation. When connected to an optional American Standard thermostat control and air distribution ducts, you have a highly efficient, total home comfort system.

Single Packaged Convertible Gas/Electric Systems are unmatched in quality and reliability. All major components on these products, including the compressor, have been designed and manufactured for maximum service. Every Duration™ two-stage compressor is designed and manufactured to exacting specifications. Each design is life tested in extreme environments to ensure reliable and long lasting operation in normal applications. Each compressor has internal motor protection for added reliability.

Contents

Optional Equipment Listing	4
<hr/>	
General Data	5
<hr/>	
Performance Data	
Indoor Fan	11
<hr/>	
Typical Wiring	14
<hr/>	
Optional Equipment	21
<hr/>	
Dimensional Data	26
<hr/>	
Mechanical Specifications	35
<hr/>	

Optional Equipment Listing

OPTIONAL EQUIPMENT FOR PACKAGED UNITS (check mark [✓] indicates accessories included)

Hinged Filter Access Door (4YCZ6024-036) ⑥	BAYACCDOR1A[]
Hinged Filter Access Door (4YCZ6048-060) ⑥	BAYACCDOR2A[]
Roof Curb Full Perimeter (4YCZ6024-036A) ③	BAYCURB050A[]
Roof Curb Full Perimeter (4YCZ6048-60A) ③	BAYCURB051A[]
Roof Curb Utility Extension Kit (BAYCURB050A)	BAYUTIL101B[]
Roof Curb Utility Extension Kit (BAYCURB051A)	BAYUTIL102B[]
Outside Air Control for V.S. Economizer (4YCZ6024-060A) ⑥	BAYOSAC001B[]
0-25% Motorized Outside Air Damper (4YCZ6024-036)	BAYDMPR101A[]
0-25% Motorized Outside Air Damper (4YCZ6048-060)	BAYDMPR102A[]
0-25% Manual Fresh Air Damper (4YCZ6024-036A) ①	BAYOSAH001A[]
0-25% Manual Fresh Air Damper (4YCZ6048-60A) ①	BAYOSAH002A[]
16" Round Duct Adapter (2 per box) (4YCZ6024-036A) ⑥	BAYSQRD001A[]
18" Round Duct Adapter (2 per box) (4YCZ6024-60A) ⑥	BAYSQRD002A[]
0-100% Mod Economizer w/Baro. Relief (4YCZ6024-036A) ①②④	BAYECON103A[]
0-100% Mod. Economizer w/Baro. Relief (4YCZ6048-60A) ①②④	BAYECON104A[]
0-100% Horizontal Economizer (4YCZ6024-036A) ①②	BAYECON203A[]
0-100% Horizontal Economizer (4YCZ6048-60A) ①②	BAYECON204A[]
Enthalpy Control for Economizer (solid state)	BAYENTH001A[]
Remote Potentiometer (All-BAYECON***A)	BAYSTAT023[]
1"-2" Filter Frame (4YCZ6024-036A) (20 x 25 filter not included) ①⑥	BAYFLTR101B[]
1"-2" Filter Frame (4YCZ6048-60A) (20 x 20,20X18 filter not included) ①⑥	BAYFLTR201B[]
LP Conversion Kit (All 40K,115K,120K Models)	BAYLPKT100A[]
LP Conversion Kit (All 60K,64K, 90K, 96K Models)	BAYLPKT101A[]
LP Conversion Kit (All 70K,75K Models)	BAYLPKT102A[]
Evaporator Defrost Control (Low Ambient Cooling) Kit ⑤	BAYLOAM011A[]
Head Pressure Control (Low Ambient Cool) (208/240v) Kit ⑤	BAYLOAM105A[]
Crankcase Heater Scroll(4YCZ6048,60A1/3)(230v) ⑤	BAYCCHT102A[]
Crankcase Heater Scroll(4YCZ6024-036)(230v) ⑤	BAYCCHT103A[]
Crankcase Heater Scroll(4YCZ6048,60)(460v) ⑤	BAYCCHT404B[]
Crankcase Heater Scroll(4YCZ6036)(460v) ⑤	BAYCCHT405A[]
Adapter Curb 4YCZ6024-036A to BAYCURB030,38	BAYADAP050A[]
Adapter Curb 4YCZ6024-036A to BAYCURB033	BAYADAP051A[]
Adapter Curb 4YCZ6048-060A to BAYCURB030,38	BAYADAP052A[]
Adapter Curb 4YCZ6048-060A to BAYCURB033	BAYADAP053A[]
Adapter Curb 4YCZ6048-060A to BAYCURB034	BAYADAP054A[]
12" Duct Shroud Covers Horizontal 4YCZ6024-060A ⑦	BAYCOVR112A[]
18" Duct Shroud Covers Horizontal 4YCZ6024-060A ⑦	BAYCOVR118A[]
Extreme Condition Mounting Kit - All BAYCURB & BAYADAP	BAYEXMK001A[]
Extreme Condition Mounting Kit - All BAYUTIL	BAYEXMK002B[]
Extreme Condition Mounting Kit - All Slab Mounts	BAYEXMK003A[]
Lifting Lug Kit - All models	BAYLIFT002B[]

- NOTES: ① Must use filter frame when economizer/fresh air kit is used.
 ② Dry bulb control standard with economizer.
 ③ Ships knocked down.
 ④ Downflow only.
 ⑤ Low Ambient cooling requires crankcase heater (BAYCCHT----A).
 ⑥ It is the responsibility of the installing dealer to properly size the ductwork for each specific application.
 ⑦ BAYCOVR112,118A will not cover BAYSQRD002A applications.
 ⑧ BAYOSAC001B is not compatible with BAYACCDOR1A or BAYACCDOR2A.
 ⑨ BAYACCDOR1A requires BAYFLTR101B & BAYACCDOR2A requires BAYFLTR201B. They are not backward compatible to BAYFLTR101/201A.

General Data

MODEL	4YCZ6024A1060A
RATED Volts/PH/Hz	208-230/1/60
Performance Cooling BTUH^①	
BTUH (High)	24000
Indoor Airflow (CFM) (High)	790
Power Input (KW)	1.83
BTUH (Low)	19200
Indoor Airflow (CFM) (Low)	570
Power Input (KW)	1.09
EER - HI / LOW / SEER	12.0 / 17.7 / 16.0
Sound Power Rating [dB(A)] ^⑦	65.4
Performance Heating^②	
Input BTUH - 1st Stage (Natural Gas)	48000
Input BTUH - 2nd Stage (Natural Gas)	60000
AFUE	81
Temp. Rise — Min/Max (°F)	40 / 70
Orifice Qty / Drill Size (Natural Gas) ^③	2 / #37
POWER CONN.—V/PH/Hz	208-230/1/60
Min. Brch. Cir. Ampacity ^④	19.5
Fuse Size — Max./Recmd. (amps)	30 / 30
COMPRESSOR	SCROLL
Volts/Ph/Hz	208-230/1/60
R.L. Amps — L.R. Amps	11.7 / 58.3
OUTDOOR COIL — TYPE	SPINE-FIN
Rows/F.P.I.	2 / 24
Face Area (sq.ft.)	13.32
Tube Size (in.)	3/8
INDOOR COIL — TYPE	MCHE
Rows/F.P.I.	2 / 16
Face Area (sq.ft.)	2.7
Tube Size (in.)	1
Refrigerant Control	EXPANSION VALVE
Drain Conn. Size (in.)	3/4 FEMALE NPT
OUTDOOR FAN — TYPE	PROPELLER
Dia. (in.)	23.4
Drive/No. Speeds	DIRECT / 1
CFM @ 0.0 in. w.g. ^⑤	2550
Motor — HP/R.P.M.	1/12 / 810
Volts/Ph/Hz	208-230/1/60
F.L. Amps/L.R. Amps	0.54 / 0.82
INDOOR FAN — TYPE	CENTRIFUGAL
Dia x Width (in.)	10 X 10
Drive/No. Speeds	DIRECT / VARIABLE
CFM @ 0.0 in. w.g. ^⑤	SEE FAN PERFORMANCE TABLE
Motor — HP/R.P.M.	1/2 / VARIABLE
Volts/Ph/Hz	208-230/1/60
F.L. Amps	4.3
COMBUSTION FAN — TYPE	CENTRIFUGAL
Drive/No. Speeds	DIRECT / 2
Motor — HP/R.P.M.	1/20 / 3350/2600
Volts/Ph/Hz	208-230/1/60
FLA	0.34
FILTER / FURNISHED	NO
Type Recommended	THROWAWAY
Recmd. Face Area (sq. ft.) ^⑥	4.0
REFRIGERANT — Charge (lbs.)^④	R410A / 6.56
Subcooling	6°
GAS PIPE SIZE (in.)	1/2
DIMENSIONS	H X W X L
Crated (in.)	46 / 45 / 52
WEIGHT — Shipping (lbs.) / Net (lbs.)	440 / 370

① Certified in accordance with the Unitary Air-Conditioner Equipment certification program, which is based on AHRI Standard 210/240.

② All models are certified to UL 1995. Ratings shown are for elevations up to 2000 ft. For higher elevations reduce ratings at a rate of 4% per 1000 ft. elevation.

③ Convertible to LPG.

④ This value is approximate. For more precise value, see Unit Nameplate.

⑤ Based on U.S. Government Standard Tests.

⑥ Filters must be installed in return air stream. Square footages listed are based on 300 f.p.m. face velocity. If permanent filters are used size per manufacturer's recommendation with a clean resistance of 0.05" W.C.

⑦ Sound Power values are not adjusted for ARI 270-95 tonal corrections.

⑧ Standard Air - Dry Coil - Outdoor.

General Data

MODEL	4YCZ6036C1070A	4YCZ6036C1090A	4YCZ6036A3075C
RATED Volts/PH/Hz	208-230/1/60	208-230/1/60	208-230/3/60
Performance Cooling BTUH^①			
BTUH (High)	35600	35600	35600
Indoor Airflow (CFM) (High)	1175	1175	1175
Power Input (KW)	2.93	2.93	2.93
BTUH (Low)	25200	25200	25200
Indoor Airflow (CFM) (Low)	830	830	830
Power Input (KW)	1.85	1.85	1.85
EER - HI / LOW / SEER	12.0 / 13.6 / 16.60	12.0 / 13.6 / 16.60	12 / 13.6 / 16.6
Sound Power Rating [dB(A)] ^⑦	70	70	70
Performance Heating^②			
Input BTUH - 1st Stage (Natural Gas)	56000	72000	56250
Input BTUH - 2nd Stage (Natural Gas)	70000	90000	75000
AFUE	81	81	79.5
Temp. Rise — Min/Max (°F)	30 / 60	40 / 70	30 / 60
Orifice Qty / Drill Size (Natural Gas) ^③	2 / #33	3 / #37	2 / #33
POWER CONN.—V/PH/HZ	208-230/1/60	208-230/1/60	208-230/3/60
Min. Brch. Cir. Ampacity ^④	26.0	26.0	19.7
Fuse Size — Max./Recmd. (amps)	40 / 40	40 / 40	30 / 30
COMPRESSOR	2-STAGE SCROLL	2-STAGE SCROLL	2-STAGE SCROLL
Volts/Ph/Hz	208-230/1/60	208-230/1/60	208-230/3/60
R.L. Amps — L.R. Amps	16.7 / 82.0	16.7 / 82.0	11.6 / 73
OUTDOOR COIL — TYPE	SPINE-FIN	SPINE-FIN	SPINE-FIN
Rows/F.P.I.	2 / 24	2 / 24	2 / 24
Face Area (sq.ft.)	15.49	15.49	15.49
Tube Size (in.)	3/8	3/8	3/8
INDOOR COIL — TYPE	PLATE FIN	PLATE FIN	PLATE FIN
Rows/F.P.I.	4 / 15	4 / 15	4 / 15
Face Area (sq.ft.)	3.54	3.54	3.54
Tube Size (in.)	3/8	3/8	3/8
Refrigerant Control	EXPANSION VALVE	EXPANSION VALVE	EXPANSION VALVE
Drain Conn. Size (in.)	3/4 FEMALE NPT	3/4 FEMALE NPT	3/4 FEMALE NPT
OUTDOOR FAN — TYPE	PROPELLER	PROPELLER	PROPELLER
Dia. (in.)	23.4	23.4	23.4
Drive/No. Speeds	DIRECT / 1	DIRECT / 1	DIRECT / 1
CFM @ 0.0 in. w.g. ^⑤	3000	3000	3000
Motor — HP/R.P.M.	1/6 / 830	1/6 / 830	1/6 / 830
Volts/Ph/Hz	208-230/1/60	208-230/1/60	208-230/1/60
F.L. Amps/L.R. Amps	0.9 / 1.65	0.9 / 1.65	0.9 / 1.65
INDOOR FAN — TYPE	CENTRIFUGAL	CENTRIFUGAL	CENTRIFUGAL
Dia x Width (in.)	10 X 10	10 X 10	10 X 10
Drive/No. Speeds	DIRECT / VARIABLE	DIRECT / VARIABLE	DIRECT / VARIABLE
CFM @ 0.0 in. w.g. ^⑤	SEE FAN PERFORMANCE TABLE	SEE FAN PERFORMANCE TABLE	SEE FAN PERFORMANCE TABLE
Motor — HP/R.P.M.	1/2 / VARIABLE	1/2 / VARIABLE	1/2 / VARIABLE
Volts/Ph/Hz	208-230/1/60	208-230/1/60	208-230/1/60
F.L. Amps/L.R. Amps	4.3 / 4.3	4.3 / 4.3	4.3 / 4.3
COMBUSTION FAN — TYPE	CENTRIFUGAL	CENTRIFUGAL	CENTRIFUGAL
Drive/No. Speeds	DIRECT / 2	DIRECT / 2	DIRECT / 2
Motor — HP/R.P.M.	1/20 / 3350/2600	1/20 / 3350/2600	1/45 / 2800/1500
Volts/Ph/Hz	208-230/1/60	208-230/1/60	208-230/1/60
FLA	0.34	0.34	0.34
FILTER / FURNISHED	NO	NO	NO
Type Recommended	THROWAWAY	THROWAWAY	THROWAWAY
Recmd. Face Area (sq. ft.) ^⑥	4.0	4.0	4.0
REFRIGERANT — Charge (lbs.)^④	R410A / 6.94	R410A / 6.94	R410A / 7.18
GAS PIPE SIZE (in.)	1/2	1/2	1/2
DIMENSIONS	H X W X L	H X W X L	H X W X L
Crated (in.)	48.0 / 44.5 / 52.0	48.0 / 44.5 / 52.0	47.86 / 44.5 / 52.03
WEIGHT— Shipping (lbs.) / Net (lbs.)	488 / 392	493 / 397	488/394

① Certified in accordance with the Unitary Air-Conditioner Equipment certification program, which is based on AHRI Standard 210/240.

② All models are certified to UL 1995. Ratings shown are for elevations up to 2000 ft. For higher elevations reduce ratings at a rate of 4% per 1000 ft. elevation.

③ Convertible to LPG.

④ This value is approximate. For more precise value, see Unit Nameplate.

⑤ Based on U.S. Government Standard Tests.

⑥ Filters must be installed in return air stream. Square footages listed are based on 300 f.p.m. face velocity. If permanent filters are used size per manufacturer's recommendation with a clean resistance of 0.05" W.C.

⑦ Sound Power values are not adjusted for ARI 270-95 tonal corrections.

⑧ Standard Air - Dry Coil - Outdoor.

General Data

MODEL	4YCZ6036A3096C	4YCZ6036A4075D	4YCZ6036A4096D
RATED Volts/PH/Hz	208-230/3/60	460/3/60	460/3/60
Performance Cooling BTUH ①			
BTUH (High)	35600	35600	35600
Indoor Airflow (CFM) (High)	1175	1175	1175
Power Input (KW)	2.93	2.93	2.93
BTUH (Low)	25200	25200	25200
Indoor Airflow (CFM) (Low)	830	830	830
Power Input (KW)	1.85	1.85	1.85
EER - HI / LOW / SEER	12 / 13.6 / 16.6	12.0 / 13.6 / 16.60	12.0 / 13.6 / 16.60
Sound Power Rating [dB(A)]⑦	70	70	70
Performance Heating ②			
Input BTUH - 1st Stage (Natural Gas)	72000	56250	72000
Input BTUH - 2nd Stage (Natural Gas)	96000	75000	96000
AFUE	80	79	80
Temp. Rise — Min/Max (°F)	40 / 70	30 / 60	40 / 70
Orifice Qty / Drill Size (Natural Gas)③	3 / #37	2 / #33	3 / #37
POWER CONN.—V/PH/Hz	208-230/3/60	460/3/60	460/3/60
Min. Brch. Cir. Ampacity④	19.7	11.9	11.9
Fuse Size — Max./Recmd. (amps)	30 / 30	15 / 15	15 / 15
COMPRESSOR	2-STAGE SCROLL	2-STAGE SCROLL	2-STAGE SCROLL
Volts/Ph/Hz	208-230/3/60	460/3/60	460/3/60
R.L. Amps — L.R. Amps	11.6 / 73	5.7 / 38.0	5.7 / 38.0
OUTDOOR COIL — TYPE	SPINE-FIN	SPINE-FIN	SPINE-FIN
Rows/F.P.I.	2 / 24	2 / 24	2 / 24
Face Area (sq.ft.)	15.49	15.49	15.49
Tube Size (in.)	3/8	3/8	3/8
INDOOR COIL — TYPE	PLATE FIN	PLATE FIN	PLATE FIN
Rows/F.P.I.	4 / 15	4 / 15	4 / 15
Face Area (sq.ft.)	3.54	3.54	3.54
Tube Size (in.)	3/8	3/8	3/8
Refrigerant Control	EXPANSION VALVE	EXPANSION VALVE	EXPANSION VALVE
Drain Conn. Size (in.)	3/4 FEMALE NPT	3/4 FEMALE NPT	3/4 FEMALE NPT
OUTDOOR FAN — TYPE	PROPELLER	PROPELLER	PROPELLER
Dia. (in.)	23.4	28.2	28.2
Drive/No. Speeds	DIRECT / 1	DIRECT / 1	DIRECT / 1
CFM @ 0.0 in. w.g. ⑤	3000	3000	3000
Motor — HP/R.P.M.	1/6 / 830	1/6 / 830	1/6 / 830
Volts/Ph/Hz	208-230/1/60	460/1/60	460/1/60
F.L. Amps/L.R. Amps	0.9 / 1.65	0.5 / 0.84	0.5 / 0.84
INDOOR FAN — TYPE	CENTRIFUGAL	CENTRIFUGAL	CENTRIFUGAL
Dia x Width (in.)	10 X 10	10 X 10	10 X 10
Drive/No. Speeds	DIRECT / VARIABLE	DIRECT / VARIABLE	DIRECT / VARIABLE
CFM @ 0.0 in. w.g. ⑤	SEE FAN PERFORMANCE TABLE	SEE FAN PERFORMANCE TABLE	SEE FAN PERFORMANCE TABLE
Motor — HP/R.P.M.	1/2 / VARIABLE	1/2 / VARIABLE	1/2 / VARIABLE
Volts/Ph/Hz	208-230/1/60	208-230/1/60	208-230/1/60
F.L. Amps/L.R. Amps	4.3 / 4.3	4.3 / 4.3	4.3 / 4.3
COMBUSTION FAN — TYPE	CENTRIFUGAL	CENTRIFUGAL	CENTRIFUGAL
Drive/No. Speeds	DIRECT / 2	DIRECT / 2	DIRECT / 2
Motor — HP/R.P.M.	1/45 / 2800/1500	1/45 / 3460/3412	1/45 / 3460/3412
Volts/Ph/Hz	208-230/1/60	208-230/1/60	208-230/1/60
FLA	0.34	0.34	0.34
FILTER / FURNISHED	NO	NO	NO
Type Recommended	THROWAWAY	THROWAWAY	THROWAWAY
Recmd. Face Area (sq. ft.)⑥	4.0	4.0	4.0
REFRIGERANT — Charge (lbs.) ④	R410A / 7.18	R410A / 7.18	R410A / 7.18
GAS PIPE SIZE (in.)	1/2	1/2	1/2
DIMENSIONS	H X W X L	H X W X L	H X W X L
Crated (in.)	47.86 / 44.5 / 52.03	48.0 / 44.5 / 52.0	48.0 / 44.5 / 52.0
WEIGHT— Shipping (lbs.) / Net (lbs.)	493 / 397	488 / 392	493 / 397

① Certified in accordance with the Unitary Air-Conditioner Equipment certification program, which is based on AHRI Standard 210/240.

② All models are certified to UL 1995. Ratings shown are for elevations up to 2000 ft. For higher elevations reduce ratings at a rate of 4% per 1000 ft. elevation.

③ Convertible to LPG.

④ This value is approximate. For more precise value, see Unit Nameplate.

⑤ Based on U.S. Government Standard Tests.

⑥ Filters must be installed in return air stream. Square footages listed are based on 300 f.p.m. face velocity. If permanent filters are used size per manufacturer's recommendation with a clean resistance of 0.05" W.C.

⑦ Sound Power values are not adjusted for ARI 270-95 tonal corrections.

⑧ Standard Air - Dry Coil - Outdoor.

General Data

MODEL	4YCZ6048C1090A	4YCZ6048C1115A	4YCZ6048A3096C
RATED Volts/PH/Hz	208-230/1/60	208-230/1/60	208-230/3/60
Performance Cooling BTUH ①			
BTUH (High)	48000	48000	48000
Indoor Airflow (CFM) (High)	1520	1520	1520
Power Input (KW)	4.0	4.0	4.0
BTUH (Low)	34800	34800	34800
Indoor Airflow (CFM) (Low)	1120	1120	1120
Power Input (KW)	2.58	2.58	2.58
EER - HI / LOW / SEER	12.0 / 13.48 / 16.00	12.0 / 13.48 / 16.00	12.0 / 13.48 / 16.00
Sound Power Rating [dB(A)]⑦	71	71	71
Performance Heating ②			
Input BTUH - 1st Stage (Natural Gas)	72000	92000	72000
Input BTUH - 2nd Stage (Natural Gas)	90000	115000	96000
AFUE	81	81	80
Temp. Rise — Min/Max (°F)	30 / 60	40 / 70	30 / 60
Orifice Qty / Drill Size (Natural Gas)③	3 / #37	3 / #32	3 / #37
POWER CONN.—V/PH/Hz	208-230/1/60	208-230/1/60	208-230/3/60
Min. Brch. Cir. Ampacity④	34.1	34.1	25.2
Fuse Size — Max./Recmd. (amps)	50 / 50	50 / 50	35 / 35
COMPRESSOR	2-STAGE SCROLL	2-STAGE SCROLL	2-STAGE SCROLL
Volts/Ph/Hz	208-230/1/60	208-230/1/60	208-230/3/60
R.L. Amps — L.R. Amps	21.2 / 104.0	21.2 / 104.0	14.0 / 83.1
OUTDOOR COIL — TYPE	SPINE-FIN	SPINE-FIN	SPINE-FIN
Rows/F.P.I.	2 / 24	2 / 24	2 / 24
Face Area (sq.ft.)	23.57	23.57	23.57
Tube Size (in.)	3/8	3/8	3/8
INDOOR COIL — TYPE	PLATE FIN	PLATE FIN	PLATE FIN
Rows/F.P.I.	4 / 15	4 / 15	4 / 15
Face Area (sq.ft.)	5.0	5.0	5.0
Tube Size (in.)	3/8	3/8	3/8
Refrigerant Control	EXPANSION VALVE	EXPANSION VALVE	EXPANSION VALVE
Drain Conn. Size (in.)	3/4 FEMALE NPT	3/4 FEMALE NPT	3/4 FEMALE NPT
OUTDOOR FAN — TYPE	PROPELLER	PROPELLER	PROPELLER
Dia. (in.)	28.2	28.2	28.2
Drive/No. Speeds	DIRECT / 1	DIRECT / 1	DIRECT / 1
CFM @ 0.0 in. w.g. ⑤	4200	4200	4200
Motor — HP/R.P.M.	1/6 / 830	1/6 / 830	1/6 / 830
Volts/Ph/Hz	208-230/1/60	208-230/1/60	208-230/1/60
F.L. Amps/L.R. Amps	0.9 / 1.65	0.9 / 1.65	0.9 / 1.65
INDOOR FAN — TYPE	CENTRIFUGAL	CENTRIFUGAL	CENTRIFUGAL
Dia x Width (in.)	11 X 10	11 X 10	11 X 10
Drive/No. Speeds	DIRECT / VARIABLE	DIRECT / VARIABLE	DIRECT / VARIABLE
CFM @ 0.0 in. w.g. ⑤	SEE FAN PERFORMANCE TABLE	SEE FAN PERFORMANCE TABLE	SEE FAN PERFORMANCE TABLE
Motor — HP/R.P.M.	3/4 / VARIABLE	3/4 / VARIABLE	3/4 / VARIABLE
Volts/Ph/Hz	208-230/1/60	208-230/1/60	208-230/1/60
F.L. Amps/L.R. Amps	6.8 / 6.8	6.8 / 6.8	6.8 / 6.8
COMBUSTION FAN — TYPE	CENTRIFUGAL	CENTRIFUGAL	CENTRIFUGAL
Drive/No. Speeds	DIRECT / 2	DIRECT / 2	DIRECT / 2
Motor — HP/R.P.M.	1/20 / 3350/2600	1/20 / 3350/2600	1/45 / 2800/1500
Volts/Ph/Hz	208-230/1/60	208-230/1/60	208-230/1/60
FLA	0.34	0.34	0.34
FILTER / FURNISHED	NO	NO	NO
Type Recommended	THROWAWAY	THROWAWAY	THROWAWAY
Recmd. Face Area (sq. ft.)⑥	5.3	5.3	5.3
REFRIGERANT — Charge (lbs.) ④	R410A / 8.77	R410A / 8.77	R410A / 8.77
GAS PIPE SIZE (in.)	1/2	1/2	1/2
DIMENSIONS	H X W X L	H X W X L	H X W X L
Crated (in.)	52.00 / 47.0 / 62.0	52.00 / 47.0 / 62.0	52.00 / 47.0 / 62.0
WEIGHT— Shipping (lbs.) / Net (lbs.)	659 / 531	665 / 537	659 / 531

① Certified in accordance with the Unitary Air-Conditioner Equipment certification program, which is based on AHRI Standard 210/240.

② All models are certified to UL 1995. Ratings shown are for elevations up to 2000 ft. For higher elevations reduce ratings at a rate of 4% per 1000 ft. elevation.

③ Convertible to LPG.

④ This value is approximate. For more precise value, see Unit Nameplate.

⑤ Based on U.S. Government Standard Tests.

⑥ Filters must be installed in return air stream. Square footages listed are based on 300 f.p.m. face velocity. If permanent filters are used size per manufacturer's recommendation with a clean resistance of 0.05" W.C.

⑦ Sound Power values are not adjusted for ARI 270-95 tonal corrections.

⑧ Standard Air - Dry Coil - Outdoor.

General Data

MODEL	4YCZ6048A3120C	4YCZ6048A4096D	4YCZ6048A4120D
RATED Volts/PH/Hz	208-230/3/60	460/3/60	460/3/60
Performance Cooling BTUH^①			
BTUH (High)	48000	48000	48000
Indoor Airflow (CFM) (High)	1520	1520	1520
Power Input (KW)	4.0	4.0	4.0
BTUH (Low)	34800	34800	34800
Indoor Airflow (CFM) (Low)	1120	1120	1120
Power Input (KW)	2.58	2.58	2.58
EER - HI / LOW / SEER	12.0 / 13.48 / 16.00	12.0 / 13.48 / 16.00	12.0 / 13.48 / 16.00
Sound Power Rating [dB(A)] ^⑦	71	71	71
Performance Heating^②			
Input BTUH - 1st Stage (Natural Gas)	90000	72000	90000
Input BTUH - 2nd Stage (Natural Gas)	120000	96000	120000
AFUE	80	80	80
Temp. Rise — Min/Max (°F)	40 / 70	30 / 60	40 / 70
Orifice Qty / Drill Size (Natural Gas) ^③	3 / #32	3 / #37	3 / #32
POWER CONN.—V/PH/Hz	208-230/3/60	460/3/60	460/3/60
Min. Brch. Cir. Ampacity ^④	25.2	15.3	15.3
Fuse Size — Max./Recmd. (amps)	35 / 35	20 / 20	20 / 20
COMPRESSOR	2-STAGE SCROLL	2-STAGE SCROLL	2-STAGE SCROLL
Volts/Ph/Hz	208-230/3/60	460/3/60	460/3/60
R.L. Amps — L.R. Amps	14.0 / 83.1	6.4 / 41.0	6.4 / 41.0
OUTDOOR COIL — TYPE	SPINE-FIN	SPINE-FIN	SPINE-FIN
Rows/F.P.I.	2 / 24	2 / 24	2 / 24
Face Area (sq.ft.)	23.57	23.57	23.57
Tube Size (in.)	3/8	3/8	3/8
INDOOR COIL — TYPE	PLATE FIN	PLATE FIN	PLATE FIN
Rows/F.P.I.	4 / 15	4 / 15	4 / 15
Face Area (sq.ft.)	5.0	5.0	5.0
Tube Size (in.)	3/8	3/8	3/8
Refrigerant Control	EXPANSION VALVE	EXPANSION VALVE	EXPANSION VALVE
Drain Conn. Size (in.)	3/4 FEMALE NPT	3/4 FEMALE NPT	3/4 FEMALE NPT
OUTDOOR FAN — TYPE	PROPELLER	PROPELLER	PROPELLER
Dia. (in.)	28.2	28.2	28.2
Drive/No. Speeds	DIRECT / 1	DIRECT / 1	DIRECT / 1
CFM @ 0.0 in. w.g. ^⑤	4200	4200	4200
Motor — HP/R.P.M.	1/6 / 830	1/6 / 830	1/6 / 830
Volts/Ph/Hz	208-230/1/60	460/1/60	460/1/60
F.L. Amps/L.R. Amps	0.9 / 1.65	0.5 / 0.84	0.5 / 0.84
INDOOR FAN — TYPE	CENTRIFUGAL	CENTRIFUGAL	CENTRIFUGAL
Dia x Width (in.)	11 X 10	11 X 10	11 X 10
Drive/No. Speeds	DIRECT / VARIABLE	DIRECT / VARIABLE	DIRECT / VARIABLE
CFM @ 0.0 in. w.g. ^⑤	SEE FAN PERFORMANCE TABLE	SEE FAN PERFORMANCE TABLE	SEE FAN PERFORMANCE TABLE
Motor — HP/R.P.M.	3/4 / VARIABLE	3/4 / VARIABLE	3/4 / VARIABLE
Volts/Ph/Hz	208-230/1/60	208-230/1/60	208-230/1/60
F.L. Amps/L.R. Amps	6.8 / 6.8	6.8 / 6.8	6.8 / 6.8
COMBUSTION FAN — TYPE	CENTRIFUGAL	CENTRIFUGAL	CENTRIFUGAL
Drive/No. Speeds	DIRECT / 2	DIRECT / 2	DIRECT / 2
Motor — HP/R.P.M.	1/45 / 2800/1500	1/45 / 3460/3412	1/45 / 3460/3412
Volts/Ph/Hz	208-230/1/60	208-230/1/60	208-230/1/60
FLA	0.34	0.34	0.34
FILTER / FURNISHED	NO	NO	NO
Type Recommended	THROWAWAY	THROWAWAY	THROWAWAY
Recmd. Face Area (sq. ft.) ^⑥	5.3	5.3	5.3
REFRIGERANT — Charge (lbs.)^④	R410A / 8.77	R410A / 8.77	R410A / 8.77
GAS PIPE SIZE (in.)	1/2	1/2	1/2
DIMENSIONS	H X W X L	H X W X L	H X W X L
Crated (in.)	52.00 / 47.0 / 62.0	52.00 / 47.0 / 62.0	52.00 / 47.0 / 62.0
WEIGHT— Shipping (lbs.) / Net (lbs.)	665 / 537	659 / 531	665 / 537

① Certified in accordance with the Unitary Air-Conditioner Equipment certification program, which is based on AHRI Standard 210/240.

② All models are certified to UL 1995. Ratings shown are for elevations up to 2000 ft. For higher elevations reduce ratings at a rate of 4% per 1000 ft. elevation.

③ Convertible to LPG.

④ This value is approximate. For more precise value, see Unit Nameplate.

⑤ Based on U.S. Government Standard Tests.

⑥ Filters must be installed in return air stream. Square footages listed are based on 300 f.p.m. face velocity. If permanent filters are used size per manufacturer's recommendation with a clean resistance of 0.05" W.C.

⑦ Sound Power values are not adjusted for ARI 270-95 tonal corrections.

⑧ Standard Air - Dry Coil - Outdoor.

General Data

MODEL	4YCZ6060C1115A	4YCZ6060A3120C	4YCZ6060A4120D
RATED Volts/PH/Hz	208-230/1/60	208-230/3/60	460/3/60
Performance Cooling BTUH ①			
BTUH (High)	57500	57500	57500
Indoor Airflow (CFM) (High)	1950	1950	1950
Power Input (KW)	5.0	5.0	5.0
BTUH (Low)	40500	40500	40500
Indoor Airflow (CFM) (Low)	1325	1325	1325
Power Input (KW)	3.2	3.2	3.2
EER - HI / LOW / SEER	11.4 / 12.65 / 15.10	11.4 / 12.65 / 15.10	11.4 / 12.65 / 15.10
Sound Power Rating [dB(A)]⑦	73	73	73
Performance Heating ②			
Input BTUH - 1st Stage (Natural Gas)	92000	90000	90000
Input BTUH - 2nd Stage (Natural Gas)	115000	120000	120000
AFUE	81	80	80
Temp. Rise — Min/Max (°F)	30 / 60	30 / 60	30 / 60
Orifice Qty / Drill Size (Natural Gas)③	3 / #32	3 / #32	3 / #32
POWER CONN.—V/PH/Hz	208-230/1/60	208-230/3/60	460/3/60
Min. Brch. Cir. Ampacity④	44.4	28.6	17.2
Fuse Size — Max./Recmd. (amps)	60 / 60	40 / 40	20 / 20
COMPRESSOR	2-STAGE SCROLL	2-STAGE SCROLL	2-STAGE SCROLL
Volts/Ph/Hz	208-230/1/60	208-230/3/60	460/3/60
R.L. Amps — L.R. Amps	28.8 / 152.9	16.2 / 110.0	7.60 / 52.0
OUTDOOR COIL — TYPE	SPINE-FIN	Spine-Fin	SPINE-FIN
Rows/F.P.I.	2 / 24	2 / 24	2 / 24
Face Area (sq.ft.)	23.57	23.57	23.57
Tube Size (in.)	3/8	3/8	3/8
INDOOR COIL — TYPE	PLATE FIN	PLATE FIN	PLATE FIN
Rows/F.P.I.	4 / 15	4 / 15	4 / 15
Face Area (sq.ft.)	5.0	5.0	5.0
Tube Size (in.)	3/8	3/8	3/8
Refrigerant Control	EXPANSION VALVE	EXPANSION VALVE	EXPANSION VALVE
Drain Conn. Size (in.)	3/4 FEMALE NPT	3/4 FEMALE NPT	3/4 FEMALE NPT
OUTDOOR FAN — TYPE	PROPELLER	PROPELLER	PROPELLER
Dia. (in.)	28.2	28.2	28.2
Drive/No. Speeds	DIRECT / 1	DIRECT / 1	DIRECT / 1
CFM @ 0.0 in. w.g.	4700	4700	4700
Motor — HP/R.P.M.	1/4 / 830	1/4 / 830	1/4 / 830
Volts/Ph/Hz	208-230/1/60	208-230/1/60	460/1/60
F.L. Amps/L.R. Amps	1.4 / 3.37	1.4 / 3.37	0.7 / 1.68
INDOOR FAN — TYPE	CENTRIFUGAL	CENTRIFUGAL	CENTRIFUGAL
Dia x Width (in.)	11 X 10	11 X 10	11 X 10
Drive/No. Speeds	DIRECT / VARIABLE	DIRECT / VARIABLE	DIRECT / VARIABLE
CFM @ 0.0 in. w.g.⑤	SEE FAN PERFORMANCE TABLE	SEE FAN PERFORMANCE TABLE	SEE FAN PERFORMANCE TABLE
Motor — HP/R.P.M.	1 / VARIABLE	1 / VARIABLE	1 / VARIABLE
Volts/Ph/Hz	208-230/1/60	208-230/1/60	208-230/1/60
F.L. Amps/L.R. Amps	6.9 / 6.9	6.9 / 6.9	6.9 / 6.9
COMBUSTION FAN — TYPE	CENTRIFUGAL	CENTRIFUGAL	CENTRIFUGAL
Drive/No. Speeds	DIRECT / 2	DIRECT / 2	DIRECT / 2
Motor — HP/R.P.M.	1/20 / 3350/2600	1/45 / 2800/1500	1/45 / 3460/3412
Volts/Ph/Hz	208-230/1/60	208-230/1/60	208-230/1/60
FLA	0.34	0.34	0.34
FILTER / FURNISHED	NO	NO	NO
Type Recommended	THROWAWAY	THROWAWAY	THROWAWAY
Recmd. Face Area (sq. ft.)⑥	5.3	5.3	5.3
REFRIGERANT — Charge (lbs.) ④	R410A / 9.30	R410A / 9.30	R410A / 9.30
GAS PIPE SIZE (in.)	1/2	1/2	1/2
DIMENSIONS	H X W X L	H X W X L	H X W X L
Crated (in.)	52.00 / 47.0 / 62.0	52.00 / 47.0 / 62.0	52.00 / 47.0 / 62.0
WEIGHT— Shipping (lbs.) / Net (lbs.)	676 / 548	676 / 548	676 / 548

① Certified in accordance with the Unitary Air-Conditioner Equipment certification program, which is based on AHRI Standard 210/240.

② All models are certified to UL 1995. Ratings shown are for elevations up to 2000 ft. For higher elevations reduce ratings at a rate of 4% per 1000 ft. elevation.

③ Convertible to LPG.

④ This value is approximate. For more precise value, see Unit Nameplate.

⑤ Based on U.S. Government Standard Tests.

⑥ Filters must be installed in return air stream. Square footages listed are based on 300 f.p.m. face velocity. If permanent filters are used size per manufacturer's recommendation with a clean resistance of 0.05" W.C.

⑦ Sound Power values are not adjusted for ARI 270-95 tonal corrections.

⑧ Standard Air - Dry Coil - Outdoor.

Indoor Blower Performance

Indoor Fan Performance 4YCZ6024

Horizontal		External Static Pressure (in. wg)									
		0.1	0.2	0.3	0.4	0.5	0.6	0.7	0.8	0.9	1.0
350 CFM/Ton Setting	Low	489	485	480	474	468	435	403	384	365	356
	High	663	666	670	661	653	635	617	596	574	556
400 CFM/Ton Setting	Low	565	569	573	560	547	533	519	493	467	451
	High	770	779	789	777	765	760	754	735	717	668
450 CFM/Ton Setting	Low	654	660	666	652	638	627	616	589	563	547
	High	874	880	887	880	873	860	846	814	782	721

Down Flow		External Static Pressure (in. wg)									
		0.1	0.2	0.3	0.4	0.5	0.6	0.7	0.8	0.9	1.0
350 CFM/Ton Setting	Low	498	489	477	467	465	439	403	392	376	367
	High	675	673	665	652	649	639	617	608	592	574
400 CFM/Ton Setting	Low	575	567	571	562	552	540	528	507	480	463
	High	783	776	786	780	771	769	768	756	735	686
450 CFM/Ton Setting	Low	658	664	672	656	640	626	617	610	594	577
	High	879	885	893	886	876	858	848	842	825	761

Indoor Fan Performance 4YCZ6036

Horizontal		External Static Pressure (in. wg)										
		0	0.1	0.2	0.3	0.4	0.5	0.6	0.7	0.8	0.9	1
350 CFM/Ton Setting	Low	-	741	743	744	744	743	742	740	737	-	-
	High	-	1059	1062	1063	1063	1062	1059	1057	1053	-	-
400 CFM/Ton Setting	Low	-	825	837	843	844	844	842	839	836	-	-
	High	-	1179	1196	1204	1206	1205	1203	1199	1194	-	-

Down Flow		External Static Pressure (in. wg)										
		0	0.1	0.2	0.3	0.4	0.5	0.6	0.7	0.8	0.9	1
350 CFM/Ton Setting	Low	-	722	745	747	744	742	743	744	736	-	-
	High	-	1032	1064	1066	1063	1060	1062	1063	1052	-	-
400 CFM/Ton Setting	Low	-	830	841	842	840	839	836	836	828	-	-
	High	-	1185	1201	1203	1201	1196	1197	1194	1184	-	-

Indoor Blower Performance

Indoor Fan Performance 4YCZ6048

Horizontal		External Static Pressure (in. wg)										
		0.0	0.1	0.2	0.3	0.4	0.5	0.6	0.7	0.8	0.9	1.0
350 CFM/Ton Setting	Low	-	954	973	977	973	966	957	950	944	-	-
	High	-	1363	1390	1396	1390	1379	1368	1358	1349	-	-
400 CFM/Ton Setting	Low	-	1121	1106	1104	1106	1108	1108	1104	1097	-	-
	High	-	1601	1580	1577	1580	1583	1583	1577	1567	-	-
450 CFM/Ton Setting	Low	-	1223	1254	1268	1271	1268	1264	1261	1258	-	-
	High	-	1747	1792	1811	1816	1812	1806	1801	1797	-	-

Down Flow		External Static Pressure (in. wg)										
		0.0	0.1	0.2	0.3	0.4	0.5	0.6	0.7	0.8	0.9	1.0
350 CFM/Ton Setting	Low	-	948	977	977	970	969	975	979	962	-	-
	High	-	1354	1396	1396	1386	1384	1393	1399	1375	-	-
400 CFM/Ton Setting	Low	-	1102	1106	1109	1113	1116	1119	1120	1118	-	-
	High	-	1574	1580	1585	1589	1594	1599	1601	1597	-	-
450 CFM/Ton Setting	Low	-	1295	1277	1272	1273	1274	1273	1272	1273	-	-
	High	-	1851	1824	1817	1818	1820	1819	1817	1819	-	-

Indoor Fan Performance 4YCZ6060

Horizontal		External Static Pressure (in. wg)										
		0.0	0.1	0.2	0.3	0.4	0.5	0.6	0.7	0.8	0.9	1.0
350 CFM/Ton Setting	Low	-	1163	1238	1259	1256	1246	1240	1237	1230	-	-
	High	-	1662	1768	1799	1794	1780	1771	1767	1757	-	-
400 CFM/Ton Setting	Low	-	1443	1427	1422	1422	1423	1422	1418	1410	-	-
	High	-	2062	2038	2031	2032	2034	2032	2025	2015	-	-

Down Flow		External Static Pressure (in. wg)										
		0.0	0.1	0.2	0.3	0.4	0.5	0.6	0.7	0.8	0.9	1.0
350 CFM/Ton Setting	Low	-	1259	1219	1208	1207	1206	1199	1188	1185	-	-
	High	-	1799	1742	1726	1725	1723	1712	1698	1692	-	-
400 CFM/Ton Setting	Low	-	1410	1393	1386	1384	1383	1380	1368	1344	-	-
	High	-	2015	1990	1980	1977	1976	1971	1955	1920	-	-

Heating Airflow, horizontal or downflow from .2 to .6" wg.

4YCZ6024A1				
Switch Settings		Selection	Nominal Airflow	
			Low Stage	High Stage
7-OFF	8-OFF	A	600	850
7-ON	8-OFF	B	625	900
7-OFF	8-ON	C	650	925
7-ON	8-ON	D	700	975

Indoor Blower Performance

Heating Airflow, horizontal or downflow from .2 to .6" wg.

4YCZ6036C*070				
Switch Settings		Selection	Nominal Airflow	
			Low Stage	High Stage
7-OFF	8-OFF	A	725	1000
7-ON	8-OFF	B	775	1075
7-OFF	8-ON	C	850	1150
7-ON	8-ON	D	925	1250

* can be 1, 3 or 4

4YCZ6036C*090				
Switch Settings		Selection	Nominal Airflow	
			Low Stage	High Stage
7-OFF	8-OFF	A	825	1100
7-ON	8-OFF	B	875	1175

* can be 1, 3 or 4

4YCZ6048C*090				
Switch Settings		Selection	Nominal Airflow	
			Low Stage	High Stage
7-OFF	8-OFF	A	1075	1375
7-ON	8-OFF	B	1100	1450
7-OFF	8-ON	C	1150	1500
7-ON	8-ON	D	1200	1575

* can be 1, 3 or 4

4YCZ6048C*115				
Switch Settings		Selection	Nominal Airflow	
			Low Stage	High Stage
7-OFF	8-OFF	A	1050	1500
7-ON	8-OFF	B	1100	1575
7-OFF	8-ON	C	1150	1625
7-ON	8-ON	D	1200	1700

* can be 1, 3 or 4

4YCZ6060C*115				
Switch Settings		Selection	Nominal Airflow	
			Low Stage	High Stage
7-OFF	8-OFF	A	1375	1800
7-ON	8-OFF	B	1450	1900

* can be 1, 3 or 4

Typical Field Wiring

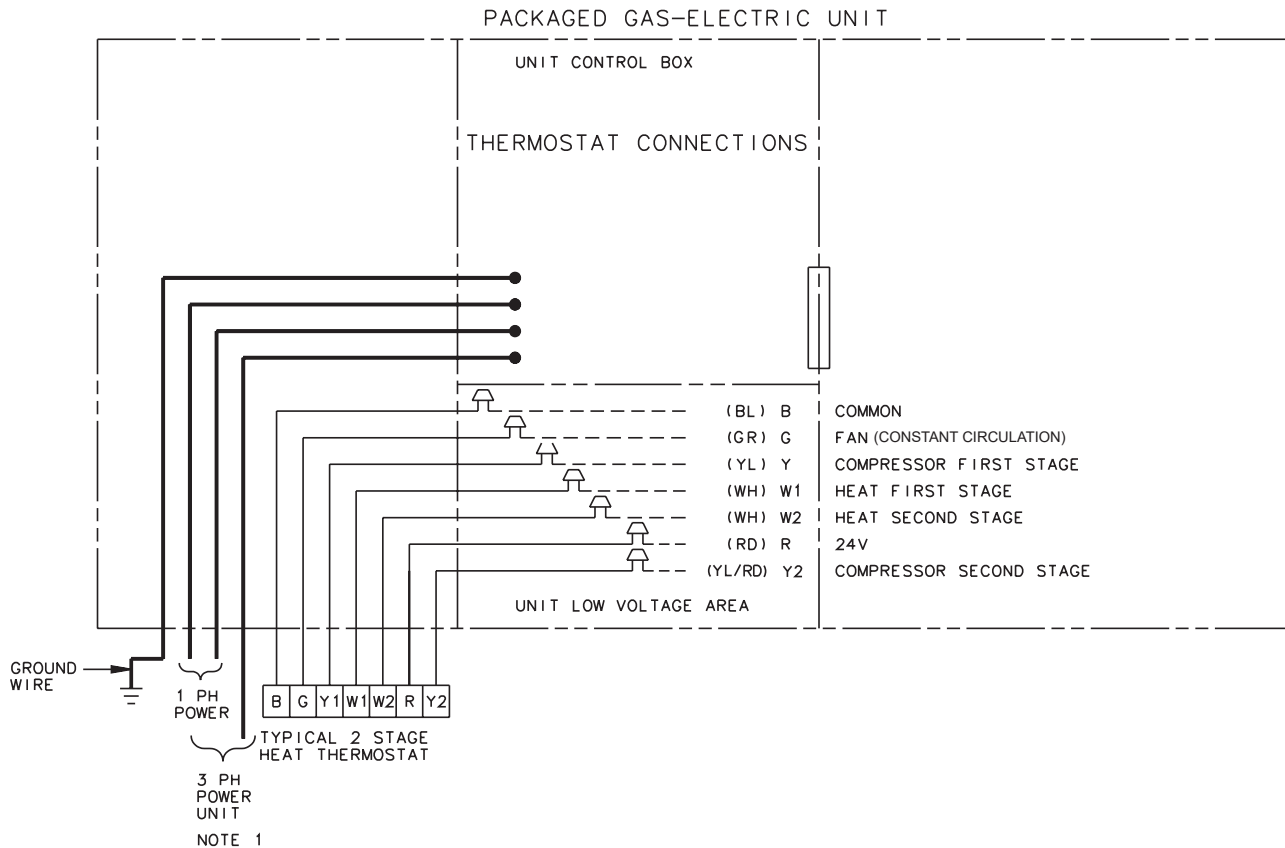

NOTES:

1. FUSED DISCONNECT SIZE, POWER WIRING AND GROUNDING OF EQUIPMENT MUST COMPLY WITH CODES.
2. BE SURE POWER SUPPLY AGREES WITH EQUIPMENT AND HEATER NAMEPLATE.
3. LOW VOLTAGE WIRING TO BE 18 AWG MINIMUM CONDUCTOR.
4. SEE UNIT DIAGRAM FOR ELECTRICAL CONNECTION DETAILS.
5. THE THERMOSTAT ON THE GAS/ELECTRIC UNIT MUST PROVIDE A 'G' SIGNAL IN THE COOLING MODE ONLY. DURING THE HEATING MODE THE FAN WILL BE ENERGIZED BY THE SYSTEM.
6. FOR SINGLE STAGE THERMOSTATS JUMPER W1 AND W2 TOGETHER. SECOND STAGE HEAT WILL BEGIN 10 MINUTES AFTER FIRST STAGE.

INTER-COMPONENT WIRING

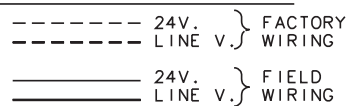

WIRE COLOR DESIGNATION			
ABBR	COLOR	ABBR	COLOR
BK	BLACK	PR	PURPLE
BL	BLUE	RD	RED
BR	BROWN	WH	WHITE
GR	GREEN	YL	YELLOW
OR	ORANGE		

Typical Wiring

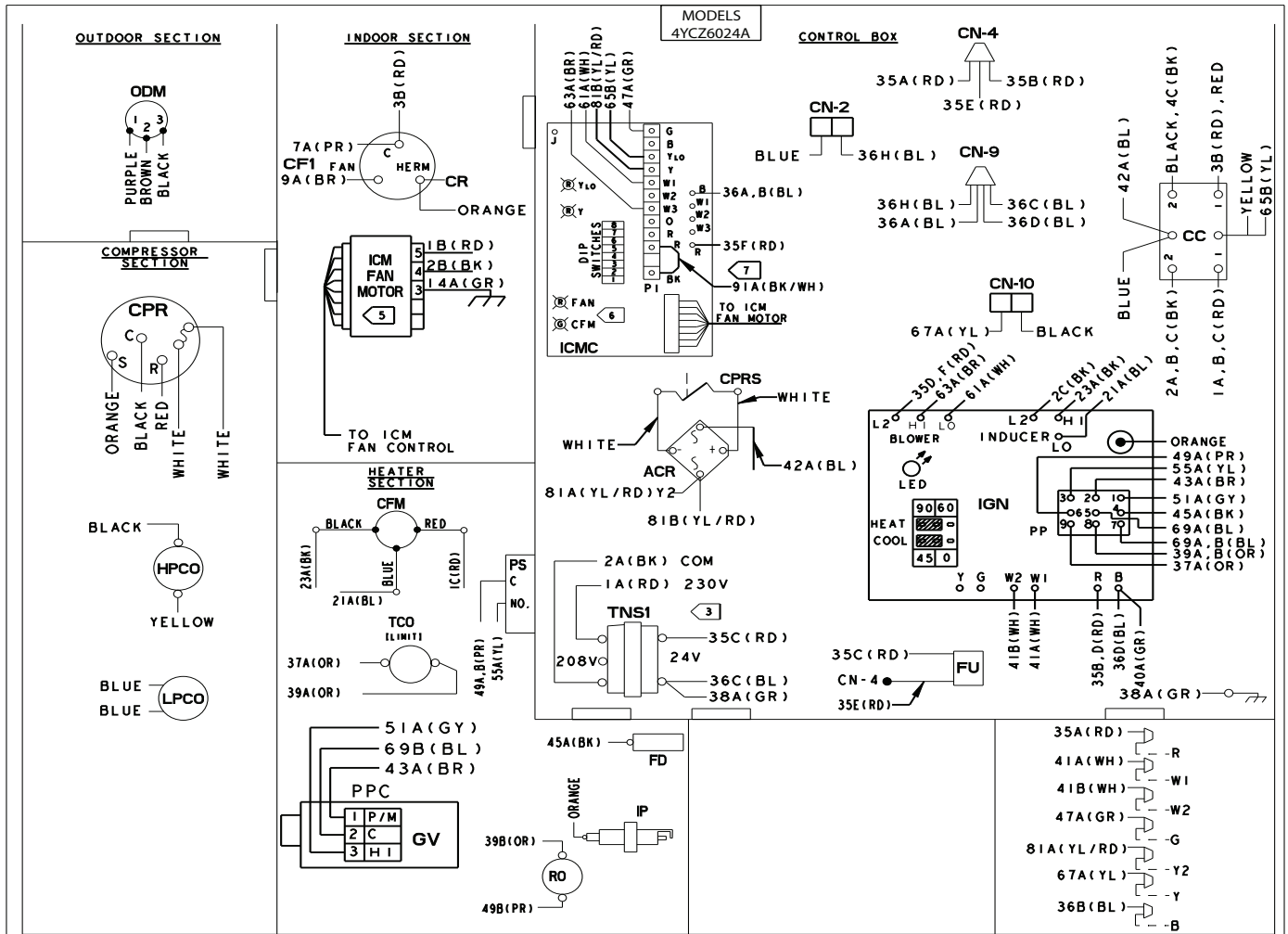

NOTES:

1. CONNECTIONS SHOWN ARE FOR A TYPICAL THERMOSTAT. SEE SCHEMATIC SUPPLIED WITH THERMOSTAT FOR PROPER CONNECTIONS. LOW VOLTAGE WIRING TO UNIT MAY BE NEC CLASS 2 AND MUST BE A MIN. OF 18 A.W.G. SET THERMOSTAT HEAT ANTICIPATOR TO .3 AMPS.
2. MAXIMUM ADDITIONAL EXTERNAL LOAD (PILOT DUTY) BETWEEN "B" AND "R" OF 0.5 AMPS, 24 VAC IS AVAILABLE IN THE COOLING MODE ONLY.
3. FOR 208 VOLT OPERATION MAKE THE FOLLOWING WIRING CHANGES:
A: AT TNS1 REMOVE 1A(RD) WIRE AND CONNECT TO 208V TERMINAL ON TRANSFORMER.
4. IF ANY OF THE ORIGINAL WIRE AS SUPPLIED IN THIS UNIT MUST BE REPLACED, REPLACE IT WITH APPLIANCE WIRING MAT'L RATED AT 105° C.
5. "T" TERMINAL IS NOT CONNECTED WHEN AN ELECTRONIC THERMOSTAT IS USED.
6. THE GREEN LED ON THE ICMC BOARD FLASHES ONCE PER HUNDRED CFM.
7. IF OPTIONAL HUMIDISTAT ACCESSORY IS USED, ON THE ICMC BOARD CUT THE 91A(BK/WH) JUMPER AND CONNECT THE HUMIDISTAT BETWEEN TERMINALS.

24 VOLT TRANSFORMER FUSE REPLACEMENT
FU 300 VOLT TYPE GMD-3.2 AMP

ABBR	COLOR	ABBR	COLOR
BK	BLACK	PR	PURPLE
BL	BLUE	RD	RED
BR	BROWN	WH	WHITE
GR	GREEN	YL	YELLOW
OR	ORANGE		

ICMC DIP SWITCH SETTINGS

DIP SWITCH SETTINGS				COOLING / HEAT PUMP CFM	NOMINAL AIRFLOW
SW 1	SW 2	SW 3	SW 4		
OFF	OFF	OFF	ON	350 CFM/TON	
OFF	OFF	OFF	OFF	400 CFM/TON	**
OFF	OFF	ON	OFF	450 CFM/TON	
FAN OFF-DELAY OPTIONS					
SW 5	SW 6				
OFF	OFF	NONE			
ON	OFF	60 SECONDS 100% NOMINAL**			
OFF	ON	90 SECONDS 50% NOMINAL			
ON	ON	ENHANCED ENHANCED			
ELECTRIC HEAT AIRFLOW					
SW 7	SW 8				
OFF	OFF	350 CFM/TON			
ON	OFF	400 CFM/TON			

** FACTORY SETTING.
AT CONTINUOUS FAN SETTING ("G" ONLY) AIRFLOW VALUES ARE APPROXIMATELY 50% OF LISTED VALUE. THE HEAT PUMP FAN OFF-DELAY IS THE SAME AS THE COOLING MODE.

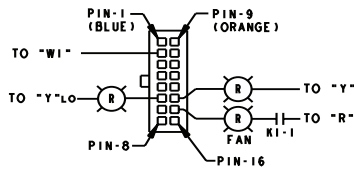

DEVICE	DESCRIPTION	LINE
CC	COMPRESSOR CONTACTOR COIL	50
CF1	OUTDOOR FAN CAPACITOR	15
CN	CONNECTOR OR WIRE NUT	
CFM	COMBUSTION FAN MOTOR	24
CPR	COMPRESSOR	14
CR	COMPRESSOR RUN CAPACITOR	14
FD	FLAME DETECTOR	37
RO	ROLLOUT LIMIT	34
GV	GAS VALVE	31
IDM	INDOOR FAN MOTOR	21
IGN	IGNITION CONTROL MODULE	23,37
IOL	INTERNAL OVERLOAD	14
IP	IGNITOR PROBE	38
LED	IGN DIAGNOSTICS INDICATOR	34
ODM	OUTDOOR FAN MOTOR	17
PP	POLARIZED PLUG	31-37
PS	PRESSURE SWITCH	34
TCO	TEMPERATURE LIMIT SWITCH	34
TNS1	CONTROL POWER TRANSFORMER	28
FU	FUSE	33
HPCO	HIGH PRESSURE SWITCH	50
LPCO	LOW PRESSURE SWITCH	49
CPRS	COMPRESSOR SOLENOID	45
ICMC	INTEGRATED MOTOR CONTROL	40-47
ACR	RECTIFIER BRIDGE	49

PRINTED FROM D758065P01

Typical Wiring

CAUTION-NOT SUITABLE FOR USE ON SYSTEMS EXCEEDING 150 VOLTS TO GROUND.
ATTENTION: NE CONVIENT PAS POUR LES INSTALLATIONS DE PLUS DE 150V. A TERRE.

MODELS
4YCZ6024A1

WARNING
HAZARDOUS VOLTAGE!
DISCONNECT ALL ELECTRIC POWER INCLUDING REMOTE DISCONNECTS BEFORE SERVICING.
FAILURE TO DISCONNECT POWER SUPPLY BEFORE SERVICING CAN CAUSE SEVERE PERSONAL INJURY OR DEATH.

AVERTISSEMENT
VOLTAGE HASARDEUX!
DECONNECTEZ TOUTES LES SOURCES ELECTRIQUES INCLUANT LES DISJONCTEURS SITUES A DISTANCE AVANT D'EFFECTUER L'ENTRETIEN. FAUTE DE DECONNECTER LA SOURCE ELECTRIQUE AVANT D'EFFECTUER L'ENTRETIEN PEUT ENTRAINDER DES BLESSURES CORPORELLES SEVERES OU LA MORT.

UNIT FACTORY WIRED FOR 230V
SEE WIRING DIAGRAM NOTES FOR REQUIRED WIRING CHANGES WHEN INSTALLED ON A 208V POWER SUPPLY.

POWER SUPPLY PER LOCAL CODES
SEE NAMEPLATE FOR LINE VOLTAGE.

CAUTION
USE COPPER CONDUCTORS ONLY!
UNIT TERMINALS ARE NOT DESIGNED TO ACCEPT OTHER TYPES OF CONDUCTORS.
FAILURE TO DO SO MAY CAUSE DAMAGE TO THE EQUIPMENT.

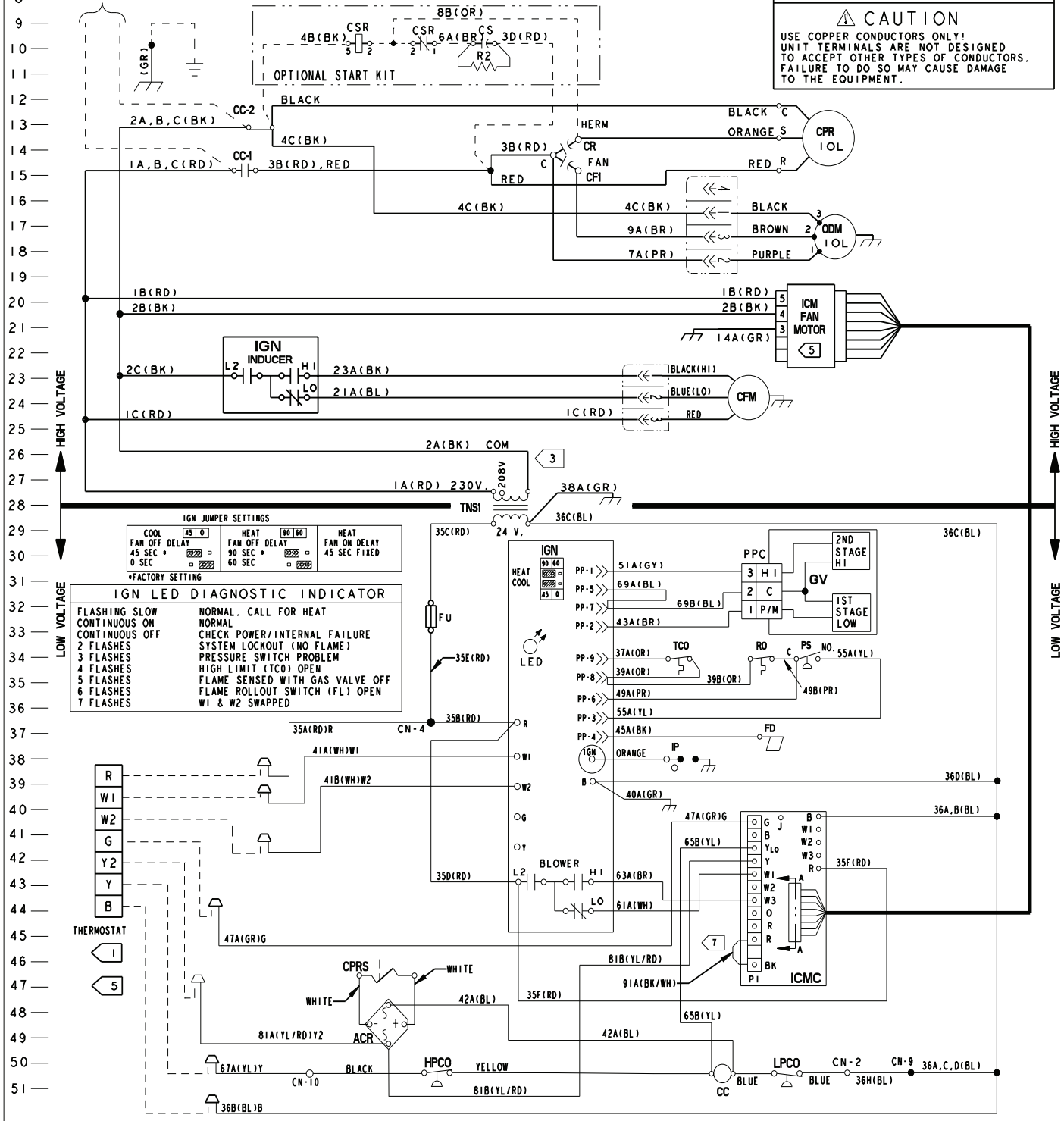

PRINTED FROM D758065P01

Typical Wiring

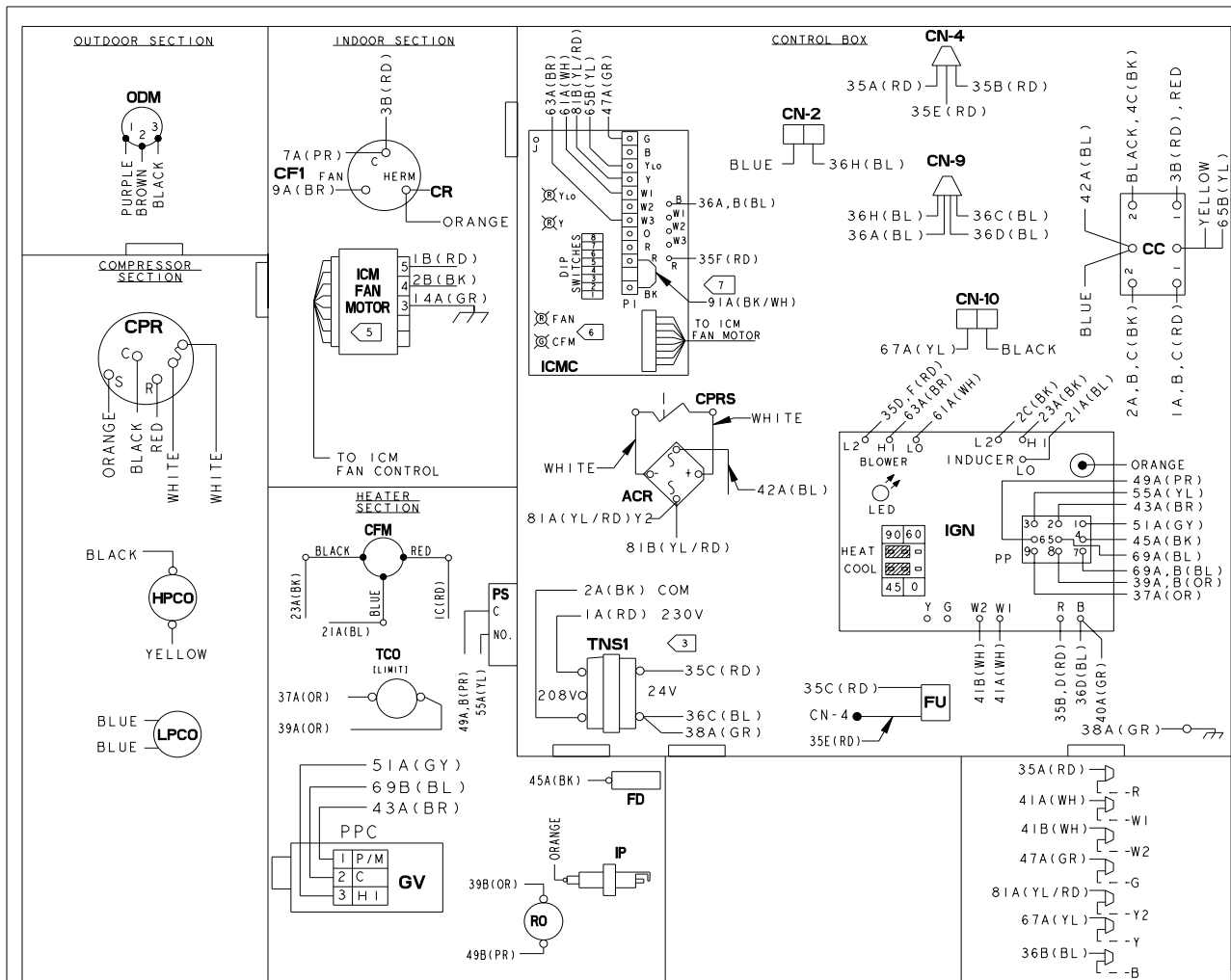

NOTES:

- CONNECTIONS SHOWN ARE FOR A TYPICAL THERMOSTAT. SEE SCHEMATIC SUPPLIED WITH THERMOSTAT FOR PROPER CONNECTIONS. LOW VOLTAGE WIRING TO UNIT MAY BE NEC CLASS 2 AND MUST BE A MIN. OF 18 A.W.G. SET THERMOSTAT HEAT ANTICIPATOR TO .3 AMPS.
- MAXIMUM ADDITIONAL EXTERNAL LOAD (PILOT DUTY) BETWEEN "B" AND "R" OF 0.5 AMPS, 24 VAC IS AVAILABLE IN THE COOLING MODE ONLY.
- FOR 208 VOLT OPERATION MAKE THE FOLLOWING WIRING CHANGES:
A: AT TNS1 REMOVE 1A(RD) WIRE AND CONNECT TO 208V TERMINAL ON TRANSFORMER.
- IF ANY OF THE ORIGINAL WIRE AS SUPPLIED IN THIS UNIT MUST BE REPLACED, REPLACE IT WITH APPLIANCE WIRING MAT'L RATED AT 105° C.
- "T" TERMINAL IS NOT CONNECTED WHEN AN ELECTRONIC THERMOSTAT IS USED.
- THE GREEN LED ON THE ICMC BOARD FLASHES ONCE PER HUNDRED CFM.
- IF OPTIONAL HUMIDISTAT ACCESSORY IS USED, ON THE ICMC BOARD CUT THE 91A(BK/WH) JUMPER AND CONNECT THE HUMIDISTAT BETWEEN TERMINALS.

24 VOLT TRANSFORMER FUSE REPLACEMENT
FU 300 VOLT TYPE GMQ-3.2 AMP

ABBR	COLOR	ABBR	COLOR
BK	BLACK	PR	PURPLE
BL	BLUE	RD	RED
BR	BROWN	WH	WHITE
GR	GREEN	YL	YELLOW
OR	ORANGE		

DEVICE	DESCRIPTION	LINE
CC	COMPRESSOR CONTACTOR COIL	50
CFI	OUTDOOR FAN CAPACITOR	15
CN	CONNECTOR OR WIRE NUT	
CFM	COMBUSTION FAN MOTOR	24
CPR	COMPRESSOR	14
CR	COMPRESSOR RUN CAPACITOR	14
FD	FLAME DETECTOR	37
RO	ROLLOUT LIMIT	34
GV	GAS VALVE	31
IDM	INDOOR FAN MOTOR	21
IGN	IGNITION CONTROL MODULE	23,37
IOL	INTERNAL OVERLOAD	14
IP	IGNITION PROBE	38
LED	IGN DIAGNOSTICS INDICATOR	34
ODM	OUTDOOR FAN MOTOR	17
PP	POLARIZED PLUG	31-37
PS	PRESSURE SWITCH	34
TCO	TEMPERATURE LIMIT SWITCH	34
TNS1	CONTROL POWER TRANSFORMER	28
FU	FUSE	33
HPCO	HIGH PRESSURE SWITCH	50
LPCO	LOW PRESSURE SWITCH	49
CPRS	COMPRESSOR SOLENOID	45
ICMC	INTEGRATED MOTOR CONTROL	40-47
ACR	RECTIFIER BRIDGE	49

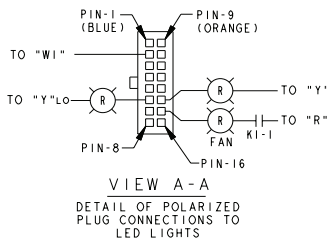

ICMC DIP SWITCH SETTINGS				
DIP SWITCH SETTINGS	COOLING/HEAT PUMP CFM	NOMINAL AIRFLOW		
SW 1 SW 2 SW 3 SW 4	350 CFM/TON			
OFF OFF OFF ON	400 CFM/TON	**		
FAN OFF-DELAY OPTIONS				
SW 5 SW 6	NONE	NOMINAL		
OFF OFF	60 SECONDS	100% NOMINAL**		
ON OFF	90 SECONDS	50% NOMINAL		
ON ON	ENHANCED	ENHANCED		
HEATING AIRFLOW				
SW 7 SW 8	350 CFM/TON			
OFF OFF	400 CFM/TON	**		
ON OFF				

** FACTORY SETTING.
AT CONTINUOUS FAN SETTING ("G" ONLY) AIRFLOW VALUES ARE APPROXIMATELY 50% OF LISTED VALUE. THE HEAT PUMP FAN OFF-DELAY IS THE SAME AS THE COOLING MODE.

Typical Wiring

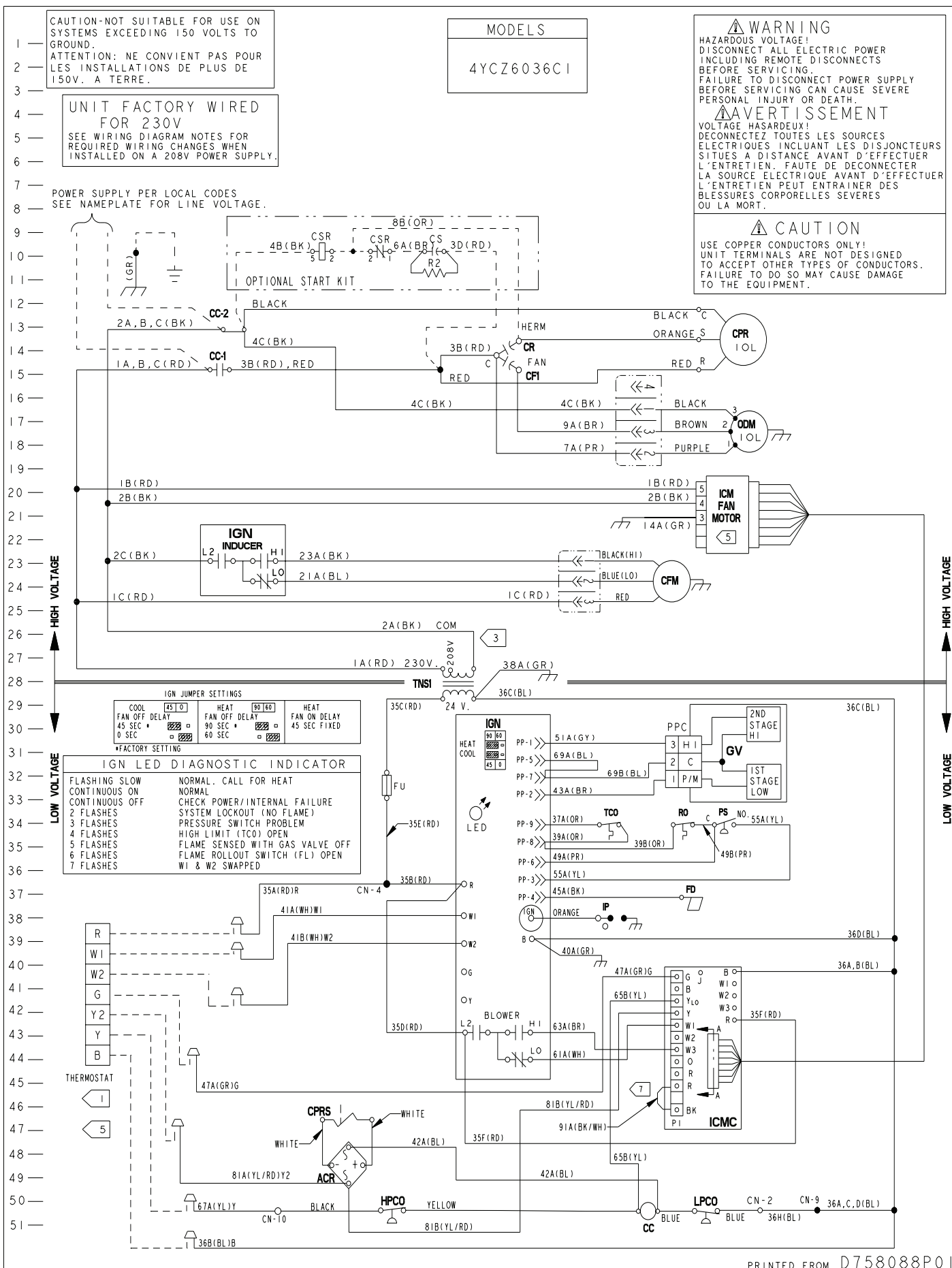

Typical Wiring

MODELS
4YCZ6048C1

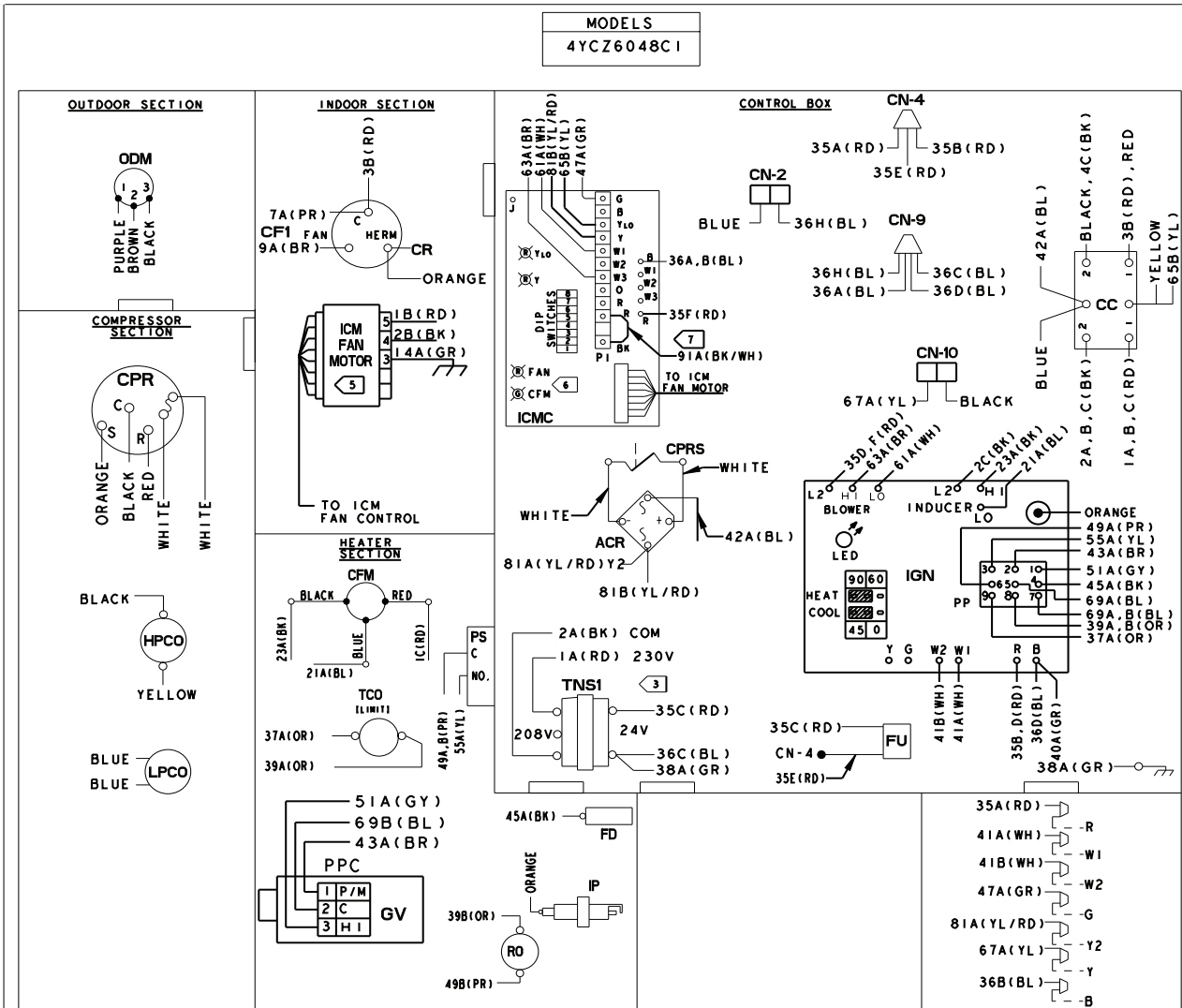

NOTES:

1. CONNECTIONS SHOWN ARE FOR A TYPICAL THERMOSTAT. SEE SCHEMATIC SUPPLIED WITH THERMOSTAT FOR PROPER CONNECTIONS. LOW VOLTAGE WIRING TO UNIT MAY BE NEC CLASS 2 AND MUST BE A MIN. OF 18 A.W.G. SET THERMOSTAT HEAT ANTICIPATOR TO .3 AMPS. MAXIMUM ADDITIONAL EXTERNAL LOAD (PILOT DUTY) BETWEEN "B" AND "R" OF 0.5 AMPS, 24 VAC IS AVAILABLE IN THE COOLING MODE ONLY.
3. FOR 208 VOLT OPERATION MAKE THE FOLLOWING WIRING CHANGES:
A: AT TNS1 REMOVE 1A(RD) WIRE AND CONNECT TO 208V TERMINAL ON TRANSFORMER.
4. IF ANY OF THE ORIGINAL WIRE AS SUPPLIED IN THIS UNIT MUST BE REPLACED, REPLACE IT WITH APPLIANCE WIRING MAT'L RATED AT 105° C.
5. "T" TERMINAL IS NOT CONNECTED WHEN AN ELECTRONIC THERMOSTAT IS USED.
6. THE GREEN LED ON THE ICMC BOARD FLASHES ONCE PER HUNDRED CFM.
7. IF OPTIONAL HUMIDISTAT ACCESSORY IS USED, ON THE ICMC BOARD CUT THE 91A(BK/WH) JUMPER AND CONNECT THE HUMIDISTAT BETWEEN TERMINALS.

24 VOLT TRANSFORMER FUSE REPLACEMENT
FU 300 VOLT TYPE GMQ-3.2 AMP

WIRE COLOR DESIGNATION			
ABBR	COLOR	ABBR	COLOR
BK	BLACK	PR	PURPLE
BL	BLUE	RD	RED
BR	BROWN	WH	WHITE
GR	GREEN	YL	YELLOW
OR	ORANGE		

DEVICE	DESCRIPTION	LINE
CC	COMPRESSOR CONTACTOR COIL	50
CFI	OUTDOOR FAN CAPACITOR	15
CN	CONNECTOR OR WIRE NUT	
CFM	COMBUSTION FAN MOTOR	24
CPR	COMPRESSOR	14
CR	COMPRESSOR RUN CAPACITOR	14
FD	FLAME DETECTOR	37
RO	ROLLOUT LIMIT	34
GV	GAS VALVE	31
IDM	INDOOR FAN MOTOR	21
IGN	IGNITION CONTROL MODULE	23,37
IOL	INTERNAL OVERLOAD	14
IP	IGNITOR PROBE	38
LED	IGN DIAGNOSTICS INDICATOR	34
ODM	OUTDOOR FAN MOTOR	17
PP	POLARIZED PLUG	31-37
PS	PRESSURE SWITCH	34
TCO	TEMPERATURE LIMIT SWITCH	34
TNS1	CONTROL POWER TRANSFORMER	28
FU	FUSE	33
HPCO	HIGH PRESSURE SWITCH	50
LPCO	LOW PRESSURE SWITCH	49
CPRS	COMPRESSOR SOLENOID	45
ICMC	INTEGRATED MOTOR CONTROL	40-47
ACR	RECTIFIER BRIDGE	49

ICMC DIP SWITCH SETTINGS

DIP SWITCH SETTINGS				COOLING / HEAT PUMP CFM	NOMINAL AIRFLOW
SW 1	SW 2	SW 3	SW 4		
OFF	OFF	OFF	ON	350 CFM/TON	
OFF	OFF	OFF	OFF	400 CFM/TON	**
OFF	OFF	ON	OFF	450 CFM/TON	
FAN OFF-DELAY OPTIONS					
SW 5	SW 6			NONE	NOMINAL
OFF	OFF			60 SECONDS	100% NOMINAL**
ON	OFF			90 SECONDS	50 x NOMINAL
ON	ON			ENHANCED	ENHANCED
ELECTRIC HEAT AIRFLOW					
SW 7	SW 8			350 CFM/TON	
OFF	OFF			400 CFM/TON	**
ON	OFF				

** FACTORY SETTING.
AT CONTINUOUS FAN SETTING ("G" ONLY) AIRFLOW VALUES ARE APPROXIMATELY 50% OF LISTED VALUE. THE HEAT PUMP FAN OFF-DELAY IS THE SAME AS THE COOLING MODE.

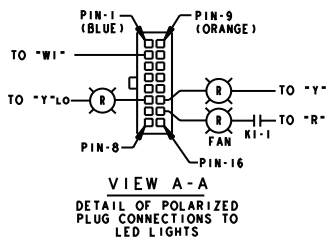

Typical Wiring

CAUTION-NOT SUITABLE FOR USE ON SYSTEMS EXCEEDING 150 VOLTS TO GROUND.
ATTENTION: NE CONVIENT PAS POUR LES INSTALLATIONS DE PLUS DE 150V. A TERRE.

UNIT FACTORY WIRED FOR 230V
SEE WIRING DIAGRAM NOTES FOR REQUIRED WIRING CHANGES WHEN INSTALLED ON A 208V POWER SUPPLY.

MODELS
4YCZ6048C1

WARNING
HAZARDOUS VOLTAGE!
DISCONNECT ALL ELECTRIC POWER INCLUDING REMOTE DISCONNECTS BEFORE SERVICING.
FAILURE TO DISCONNECT POWER SUPPLY BEFORE SERVICING CAN CAUSE SEVERE PERSONAL INJURY OR DEATH.

AVERTISSEMENT
VOLTAGE HASARDEUX!
DECONNECTEZ TOUTES LES SOURCES ELECTRIQUES INCLUANT LES DISJONCTEURS SITUES A DISTANCE AVANT D'EFFECTUER L'ENTRETIEN. FAUTE DE DECONNECTER LA SOURCE ELECTRIQUE AVANT D'EFFECTUER L'ENTRETIEN PEUT ENTRAINER DES BLESSURES CORPORELLES SEVERES OU LA MORT.

CAUTION
USE COPPER CONDUCTORS ONLY!
UNIT TERMINALS ARE NOT DESIGNED TO ACCEPT OTHER TYPES OF CONDUCTORS. FAILURE TO DO SO MAY CAUSE DAMAGE TO THE EQUIPMENT.

POWER SUPPLY PER LOCAL CODES
SEE NAMEPLATE FOR LINE VOLTAGE.

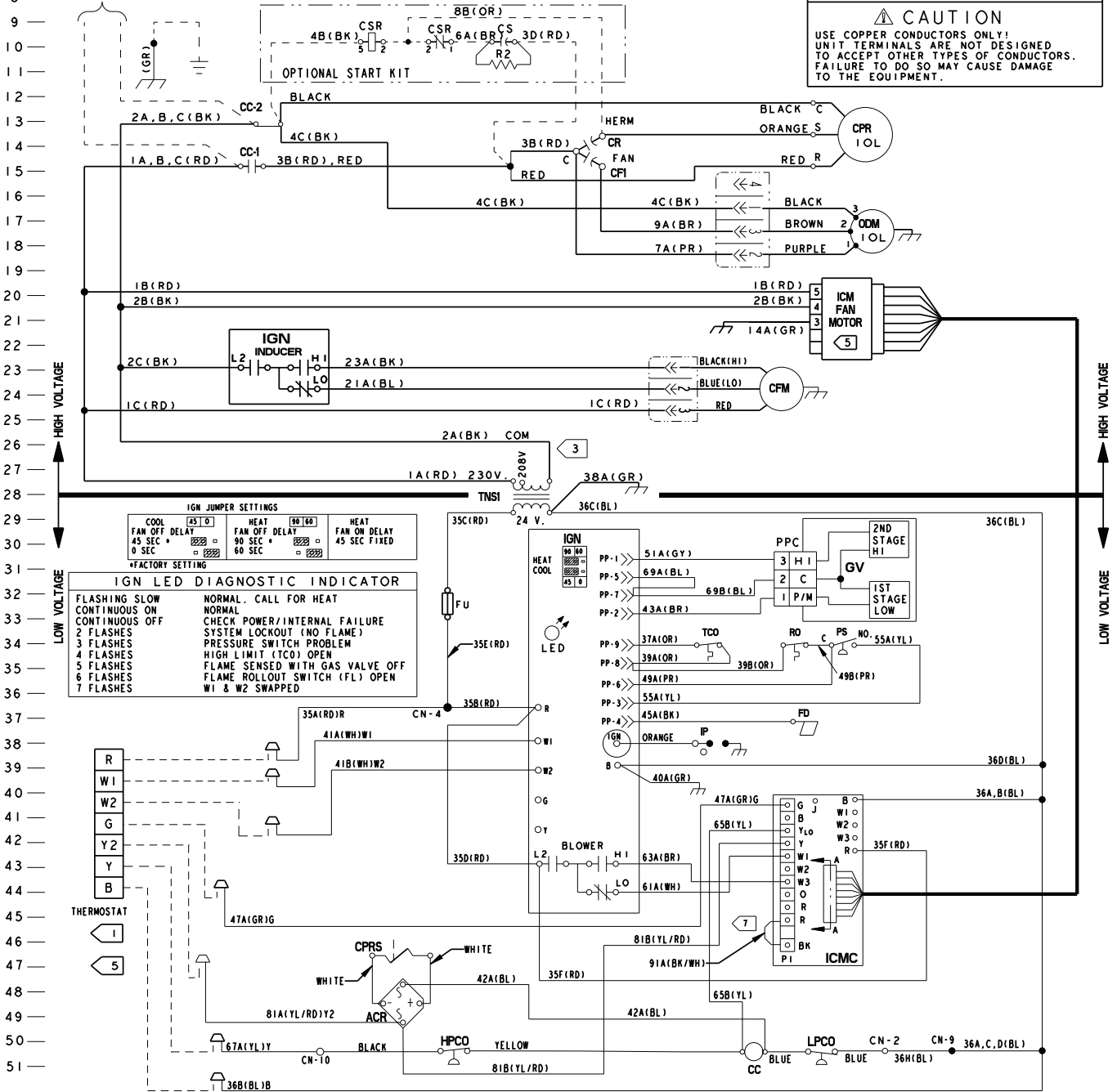

IGN JUMPER SETTINGS			
COOL	45 0	HEAT	90 60
FAN OFF DELAY	0 SEC	FAN OFF DELAY	90 SEC
0 SEC		FAN ON DELAY	45 SEC
		45 SEC	
*FACTORY SETTING			

IGN LED DIAGNOSTIC INDICATOR	
FLASHING SLOW	NORMAL. CALL FOR HEAT
CONTINUOUS ON	NORMAL
CONTINUOUS OFF	CHECK POWER/INTERNAL FAILURE
2 FLASHES	SYSTEM LOCKOUT (NO FLAME)
3 FLASHES	PRESSURE SWITCH PROBLEM
4 FLASHES	HIGH LIMIT (TCO) OPEN
5 FLASHES	FLAME SENSED WITH GAS VALVE OFF
6 FLASHES	FLAME ROLLOUT SWITCH (FL) OPEN
7 FLASHES	W1 & W2 SWAPPED

PRINTED FROM D758050P01

Typical Wiring

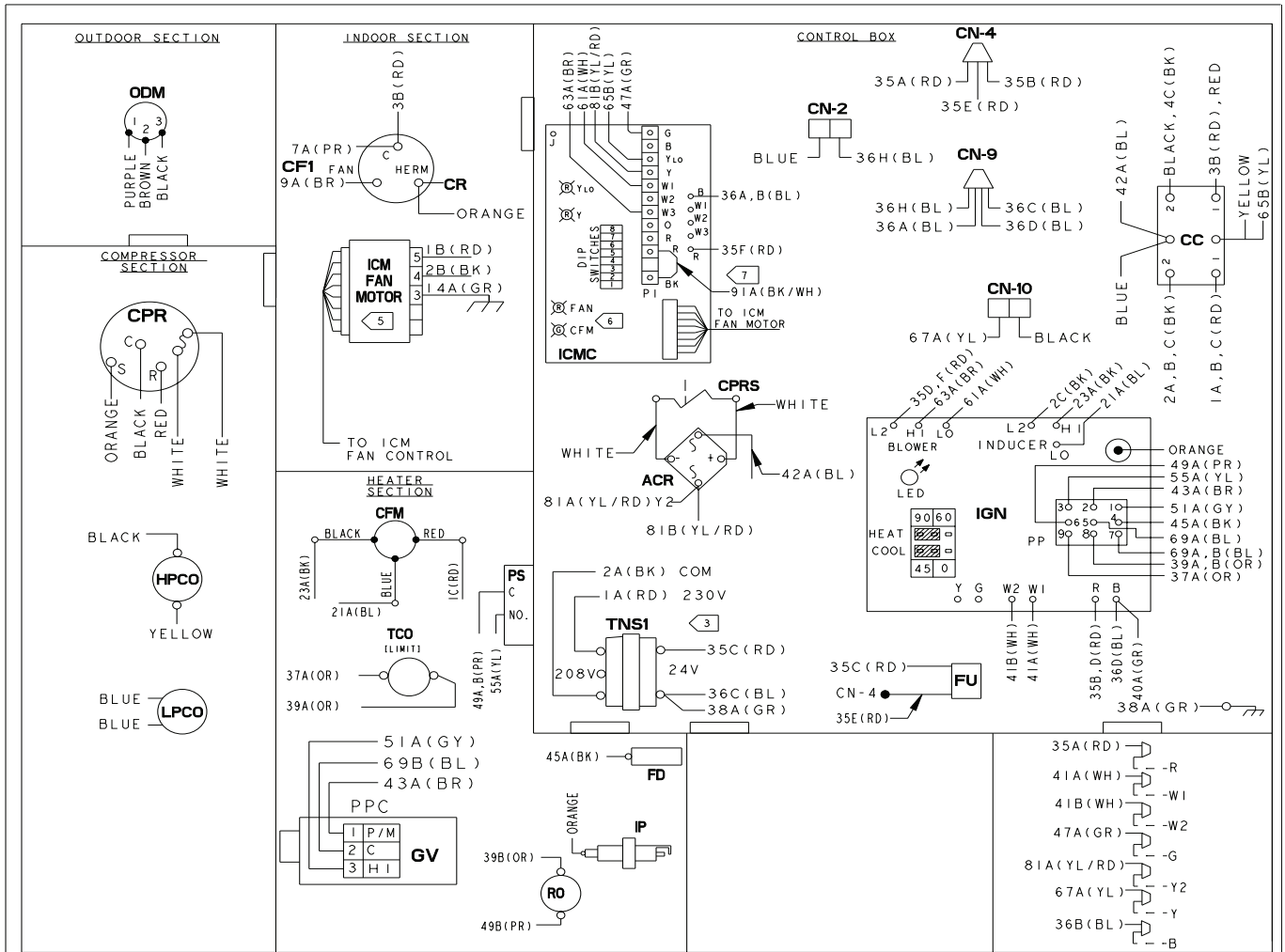

NOTES:

1. CONNECTIONS SHOWN ARE FOR A TYPICAL THERMOSTAT. SEE SCHEMATIC SUPPLIED WITH THERMOSTAT FOR PROPER CONNECTIONS. LOW VOLTAGE WIRING TO UNIT MAY BE NEC CLASS 2 AND MUST BE A MIN. OF 18 A.W.G. SET THERMOSTAT HEAT ANTICIPATOR TO .3 AMPS.
2. MAXIMUM ADDITIONAL EXTERNAL LOAD (PILOT DUTY) BETWEEN "B" AND "R" OF 0.5 AMPS, 24 VAC IS AVAILABLE IN THE COOLING MODE ONLY.
3. FOR 208 VOLT OPERATION MAKE THE FOLLOWING WIRING CHANGES:
A: AT TNS1 REMOVE 1A(RD) WIRE AND CONNECT TO 208V TERMINAL ON TRANSFORMER.
4. IF ANY OF THE ORIGINAL WIRE AS SUPPLIED IN THIS UNIT MUST BE REPLACED, REPLACE IT WITH APPLIANCE WIRING MAT'L RATED AT 105° C.
5. "T" TERMINAL IS NOT CONNECTED WHEN AN ELECTRONIC THERMOSTAT IS USED.
6. THE GREEN LED ON THE ICMC BOARD FLASHES ONCE PER HUNDRED CFM.
7. IF OPTIONAL HUMIDISTAT ACCESSORY IS USED, ON THE ICMC BOARD CUT THE 91A(BK/WH) JUMPER AND CONNECT THE HUMIDISTAT BETWEEN TERMINALS.

24 VOLT TRANSFORMER FUSE REPLACEMENT
FU 300 VOLT TYPE GMQ-3.2 AMP

ABBR	COLOR	ABBR	COLOR
BK	BLACK	PR	PURPLE
BL	BLUE	RD	RED
BR	BROWN	WH	WHITE
GR	GREEN	YL	YELLOW
OR	ORANGE		

DEVICE	DESCRIPTION	LINE
CC	COMPRESSOR CONTACTOR COIL	50
CF1	OUTDOOR FAN CAPACITOR	15
CN	CONNECTOR OR WIRE NUT	
CFM	COMBUSTION FAN MOTOR	24
CPR	COMPRESSOR	14
CR	COMPRESSOR RUN CAPACITOR	14
FD	FLAME DETECTOR	37
RO	ROLLOUT LIMIT	34
GV	GAS VALVE	31
IDM	INDOOR FAN MOTOR	21
IGN	IGNITION CONTROL MODULE	23, 37
IOL	INTERNAL OVERLOAD	14
IP	IGNITOR PROBE	38
LED	IGN DIAGNOSTICS INDICATOR	34
ODM	OUTDOOR FAN MOTOR	17
PP	POLARIZED PLUG	31-37
PS	PRESSURE SWITCH	34
TCO	TEMPERATURE LIMIT SWITCH	34
TNS1	CONTROL POWER TRANSFORMER	28
FU	FUSE	33
HPCO	HIGH PRESSURE SWITCH	50
LPCO	LOW PRESSURE SWITCH	49
CPRS	COMPRESSOR SOLENOID	45
ICMC	INTEGRATED MOTOR CONTROL	40-47
ACR	RECTIFIER BRIDGE	49

ICMC DIP SWITCH SETTINGS

DIP SWITCH SETTINGS				HEATING AIRFLOW	
SW 1	SW 2	SW 3	SW 4	COOLING / HEAT PUMP CFM	NOMINAL AIRFLOW
OFF	OFF	OFF	ON	350 CFM/TON	
OFF	OFF	OFF	OFF	400 CFM/TON	**
				FAN OFF-DELAY OPTIONS	
OFF	OFF			NONE	NOMINAL
ON	OFF			60 SECONDS	100% NOMINAL**
OFF	ON			90 SECONDS	50% NOMINAL
ON	ON			ENHANCED	ENHANCED
				HEATING AIRFLOW	
OFF	OFF			350 CFM/TON	
ON	OFF			400 CFM/TON	**

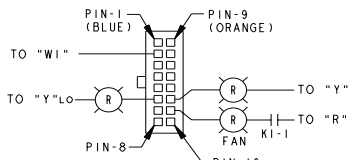

** FACTORY SETTING.
AT CONTINUOUS FAN SETTING ("G" ONLY) AIRFLOW VALUES ARE APPROXIMATELY 50% OF LISTED VALUE. THE HEAT PUMP FAN OFF-DELAY IS THE SAME AS THE COOLING MODE.

Typical Wiring

CAUTION-NOT SUITABLE FOR USE ON SYSTEMS EXCEEDING 150 VOLTS TO GROUND.
ATTENTION: NE CONVIENT PAS POUR LES INSTALLATIONS DE PLUS DE 150V. A TERRE.

UNIT FACTORY WIRED FOR 230V
SEE WIRING DIAGRAM NOTES FOR REQUIRED WIRING CHANGES WHEN INSTALLED ON A 208V POWER SUPPLY.

MODELS

4YCZ6060C1

WARNING
HAZARDOUS VOLTAGE!
DISCONNECT ALL ELECTRIC POWER INCLUDING REMOTE DISCONNECTS BEFORE SERVICING.
FAILURE TO DISCONNECT POWER SUPPLY BEFORE SERVICING CAN CAUSE SEVERE PERSONAL INJURY OR DEATH.

AVERTISSEMENT
VOLTAGE HASARDEUX!
DECONNECTEZ TOUTES LES SOURCES ELECTRIQUES INCLUANT LES DISJONCTEURS SITUES A DISTANCE AVANT D'EFFECTUER L'ENTRETIEN. FAUTE DE DECONNECTER LA SOURCE ELECTRIQUE AVANT D'EFFECTUER L'ENTRETIEN PEUT ENTRAINER DES BLESSURES CORPORELLES SEVERES OU LA MORT.

CAUTION
USE COPPER CONDUCTORS ONLY!
UNIT TERMINALS ARE NOT DESIGNED TO ACCEPT OTHER TYPES OF CONDUCTORS.
FAILURE TO DO SO MAY CAUSE DAMAGE TO THE EQUIPMENT.

POWER SUPPLY PER LOCAL CODES
SEE NAMEPLATE FOR LINE VOLTAGE.

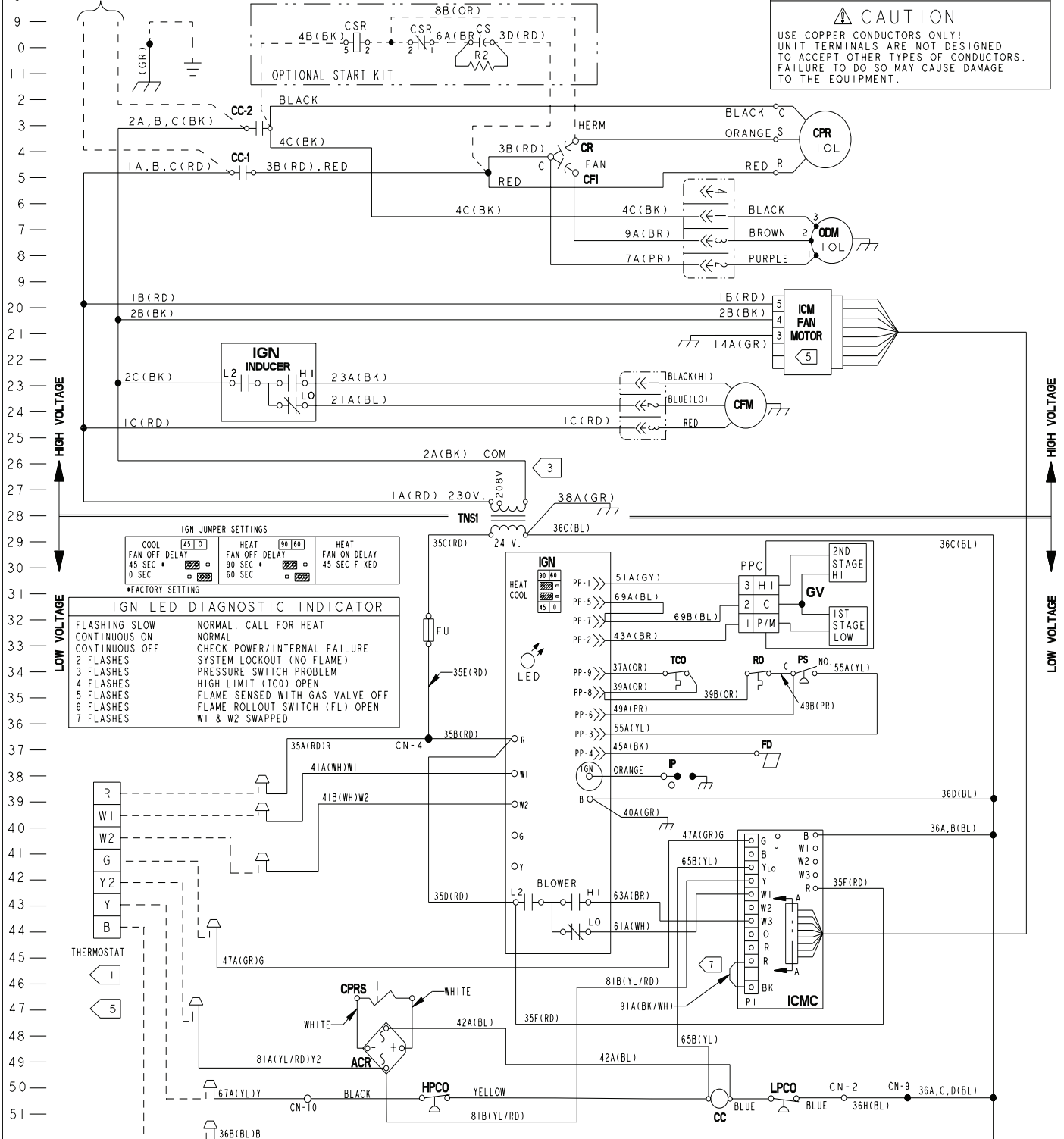

PRINTED FROM D758091P01

Optional Equipment

BAYCURB050A FULL PERIMETER ROOF MOUNTING CURB FOR 4YCZ6024/36

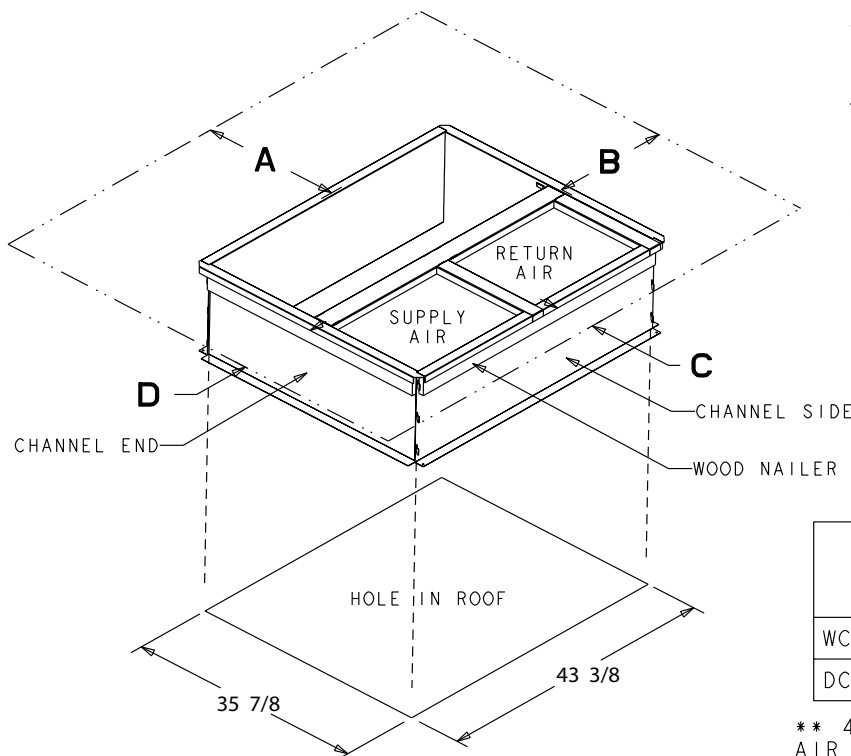
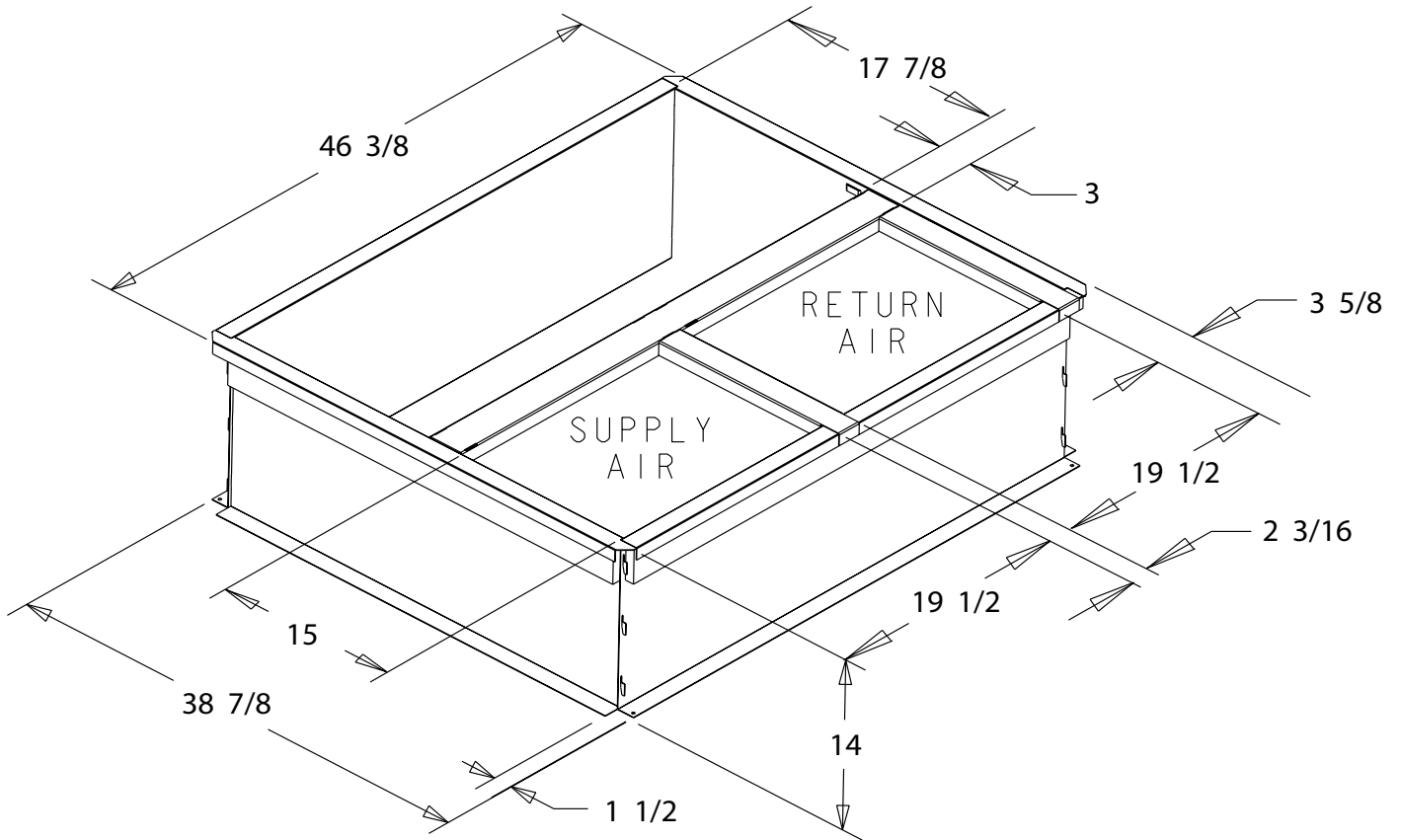

The drawings on this page are prepared by the manufacturer in order to provide detail regarding job layout only. These drawings are not intended to be used as a basis to construct, build or modify the items depicted in the drawings. The manufacturer is not responsible for the unauthorized use of these drawings and expressly disclaims any liability for damages resulting from such unauthorized use.

	SERVICE CLEARANCE DIMENSIONS			
	A	B	C	D
WC*/TC*	42.00	36.00	12.00**	24.00
DC*/YC*	42.00	36.00	12.00**	36.00

** 42.00 WITH ECONOMIZER WITH 25% FRESH AIR ACCESSORY

Optional Equipment

BAYCURB051A Full Perimeter Roof Mounting Curb for 4YCZ6048-060

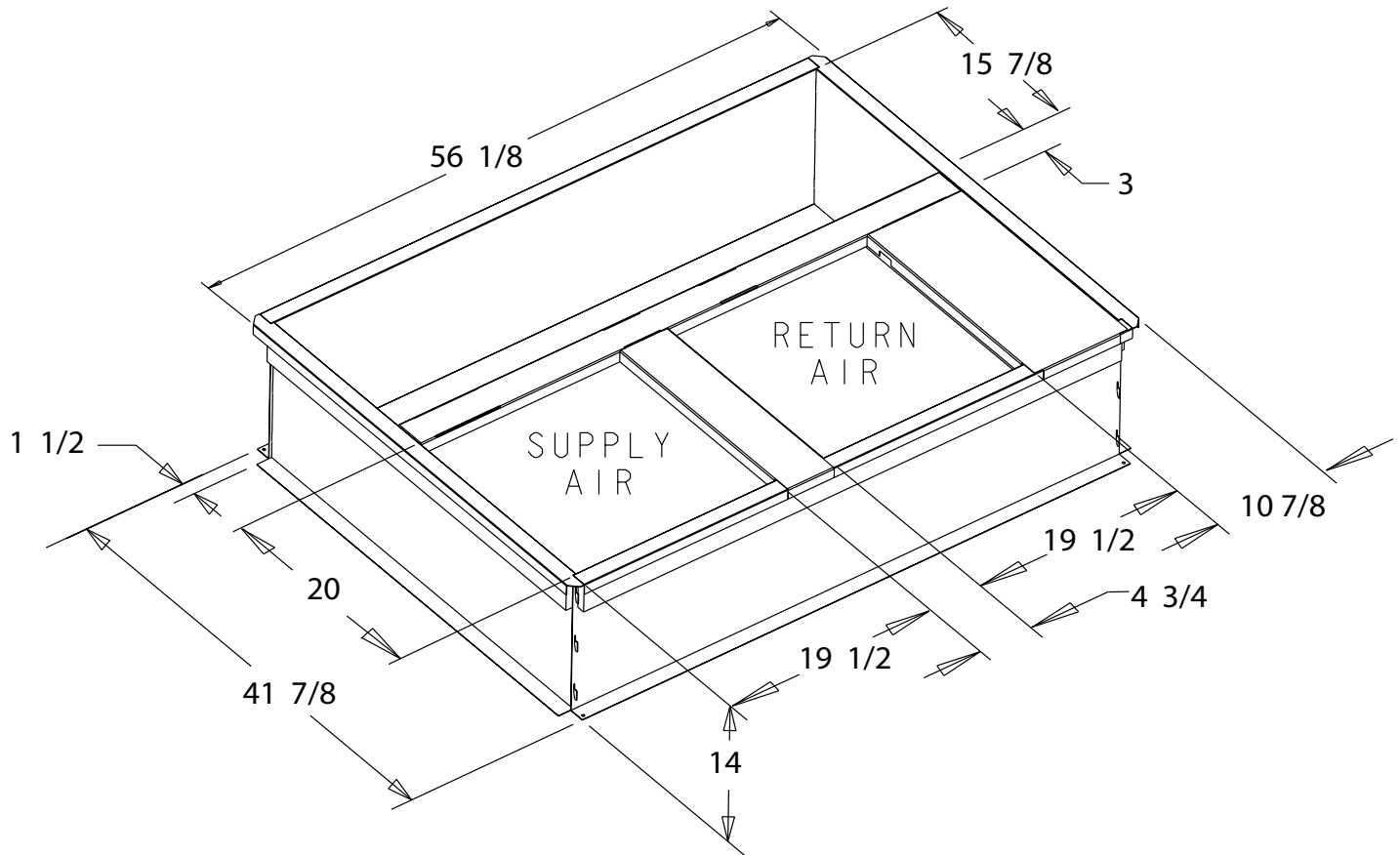

The drawings on this page are prepared by the manufacturer in order to provide detail regarding job layout only. These drawings are not intended to be used as a basis to construct, build or modify the items depicted in the drawings. The manufacturer is not responsible for the unauthorized use of these drawings and expressly disclaims any liability for damages resulting from such unauthorized use.

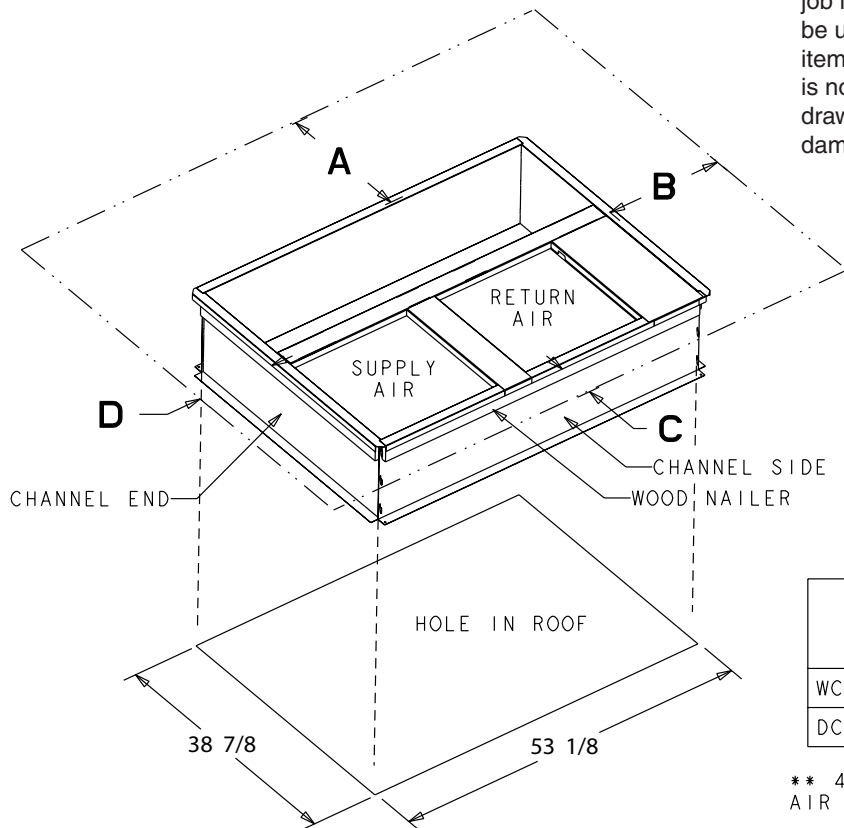

	SERVICE CLEARANCE DIMENSIONS			
	A	B	C	D
WC*/TC*	42.00	36.00	12.00**	24.00
DC*/YC*	42.00	36.00	12.00**	36.00

** 42.00 WITH ECONOMIZER WITH 25% FRESH AIR ACCESSORY

Optional Equipment

BAYFLTR101, 201B, 1" - 2" Filter Rack (Mounts in Filter/Coil Section)

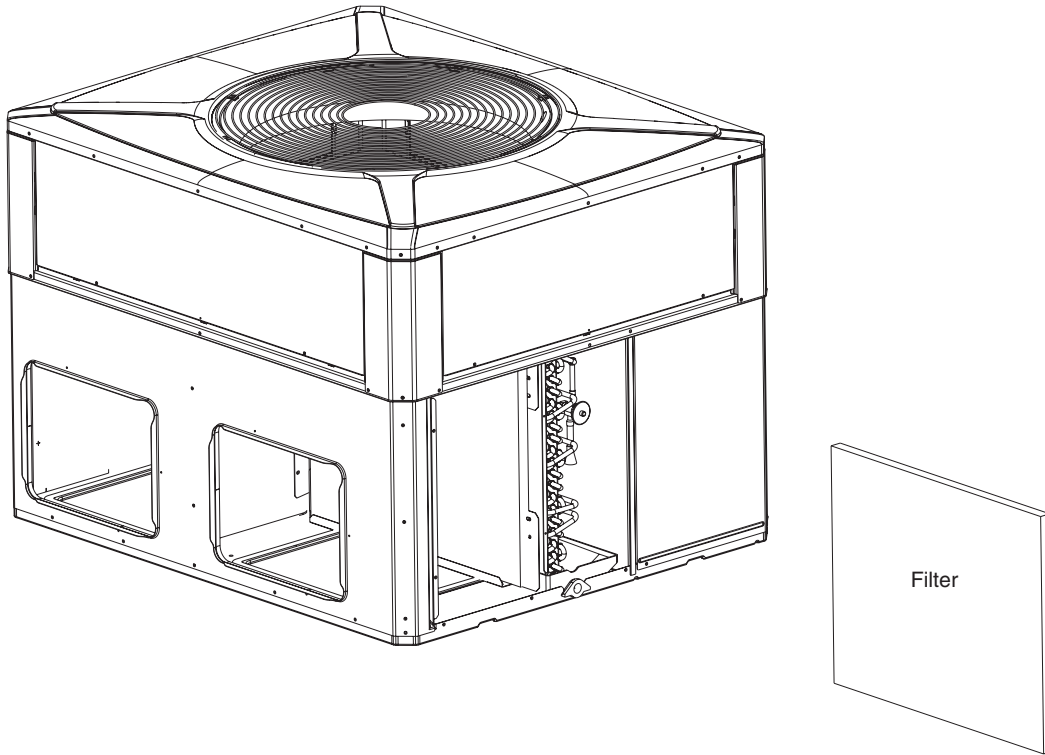

BAYACCDOR1A & BAYACCDOR2A Hinged Filter Access Door Replaces Filter/Coil Access Panel

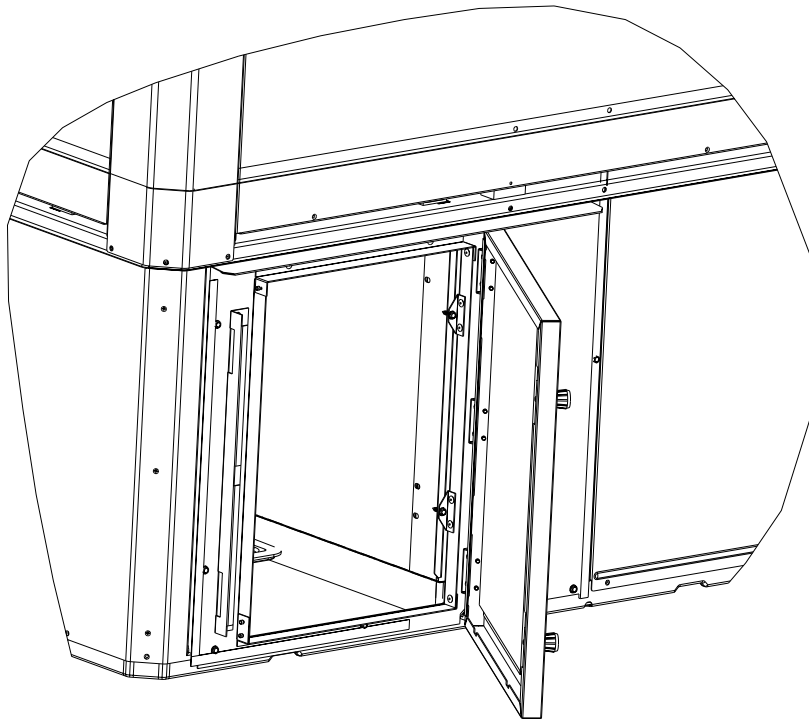

The drawings on this page are prepared by the manufacturer in order to provide detail regarding job layout only. These drawings are not intended to be used as a basis to construct, build or modify the items depicted in the drawings. The manufacturer is not responsible for the unauthorized use of these drawings and expressly disclaims any liability for damages resulting from such unauthorized use.

Optional Equipment

BAYECON103,104A Down Discharge Economizer and Rain Hood (Mounts Over Horizontal Return Air Opening)

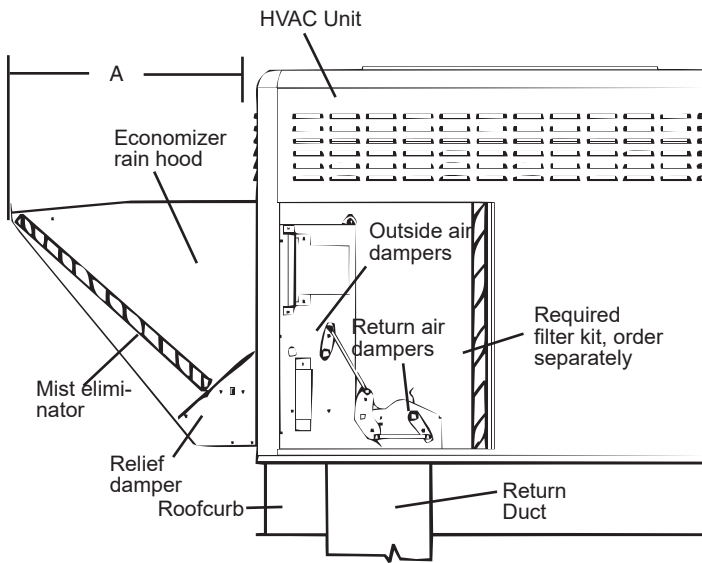

Economizer	Models	A
BAYECON103A	4WCZ6036A 4DCZ6036A 4YCZ6024A 4YCZ6036A	20 1/8"
BAYECON104A	4WCZ6048-060A 4DCZ6048-060A 4YCZ6048-060A	24 3/8"

BAYECON203,204A Horizontal Economizer and Rain Hood

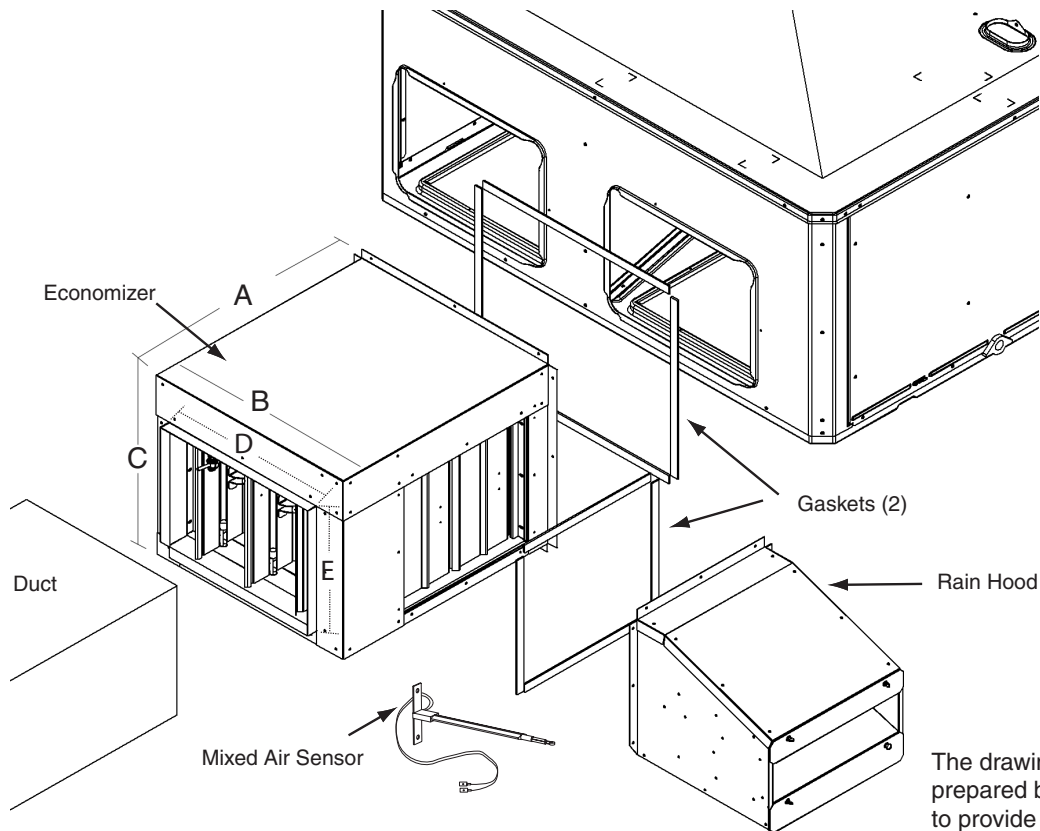

The drawings on this page are prepared by the manufacturer in order to provide detail regarding job layout only. These drawings are not intended to be used as a basis to construct, build or modify the items depicted in the drawings. The manufacturer is not responsible for the unauthorized use of these drawings and expressly disclaims any liability for damages resulting from such unauthorized use.

Economizer	A	B	C	D	E	F
BAYECON203AA	22"	20"	16 7/8	15 11/16	11 11/16	15
BAYECON204AA	26"	22 21/32"	19"	17 11/16	14 11/16	21-3/8

Optional Equipment

BAYOSAH001,002A, 25% Outside Air Damper (Replaces Filter/Coil Access Panel)

The drawings on this page are prepared by the manufacturer in order to provide detail regarding job layout only. These drawings are not intended to be used as a basis to construct, build or modify the items depicted in the drawings. The manufacturer is not responsible for the unauthorized use of these drawings and expressly disclaims any liability for damages resulting from such unauthorized use.

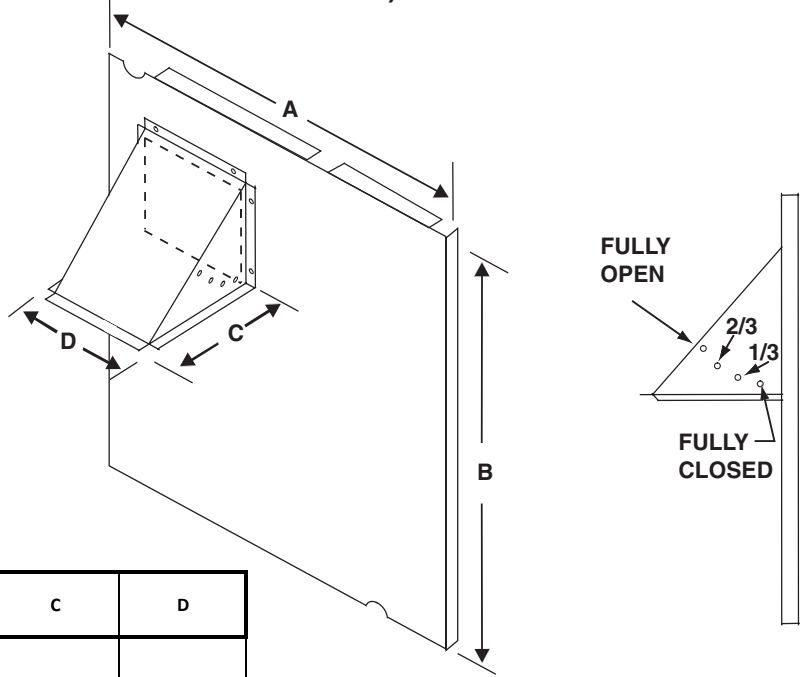

Manual Fresh Air Model	Unit Application Models	A	B	C	D
BAYOSAH001	2.0 - 3.0 Ton Models	22 7/16"	20 11/16"	12 3/8"	9 3/16"
BAYOSAH002	3.5 - 5.0 Ton Models	25 3/16"	20 11/16"	12 3/8"	9 3/16"

BAYDMPR101,102A, 25% Motorized Outside Air Damper (Mounts Over Horizontal Return Air Opening)

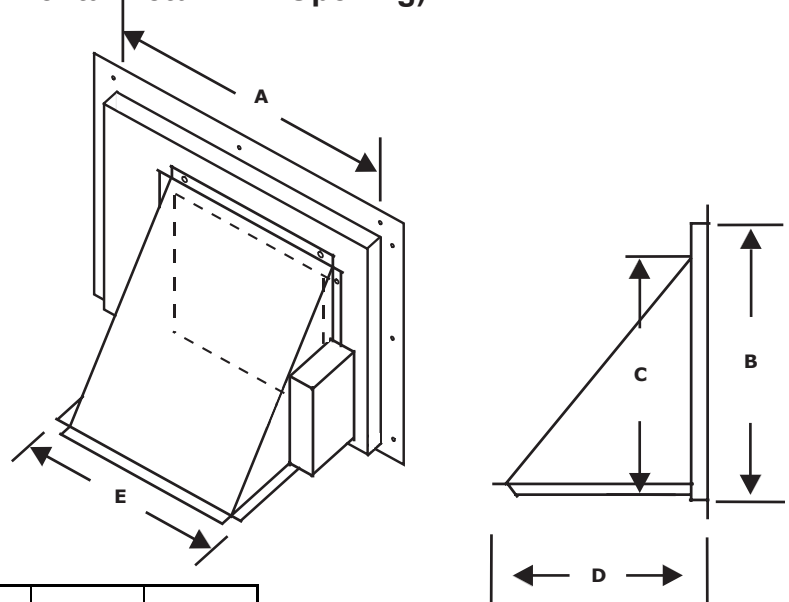

	Unit Application Models	A	B	C	D	E
BAYDMPR101A	2.0-3.0 Ton Models	15 13/16"	11 13/16"	10 1/4"	11 1/2"	12 1/4"
BAYDMPR102A	3.5 - 5.0 Ton Models	18 3/16"	15 1/8"	10 1/4"	11 1/2"	12 1/4"

Dimensional Data

SECTION X-X
TYPICAL (8) SIDES OF SIDEFLOW DUCT OPENINGS



SECTION Y-Y
TYPICAL (8) SIDES OF DOWNFLOW DUCT OPENINGS

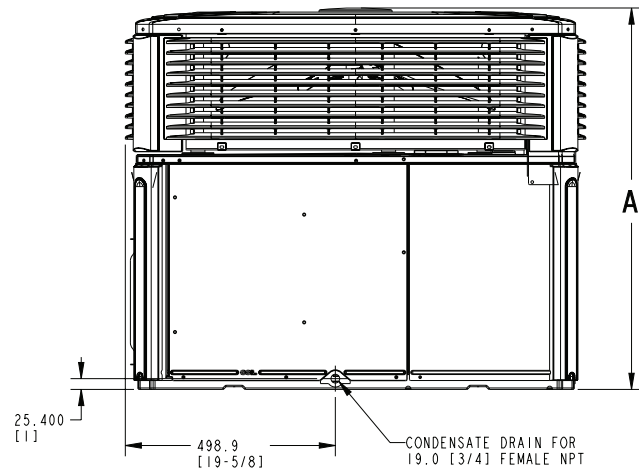
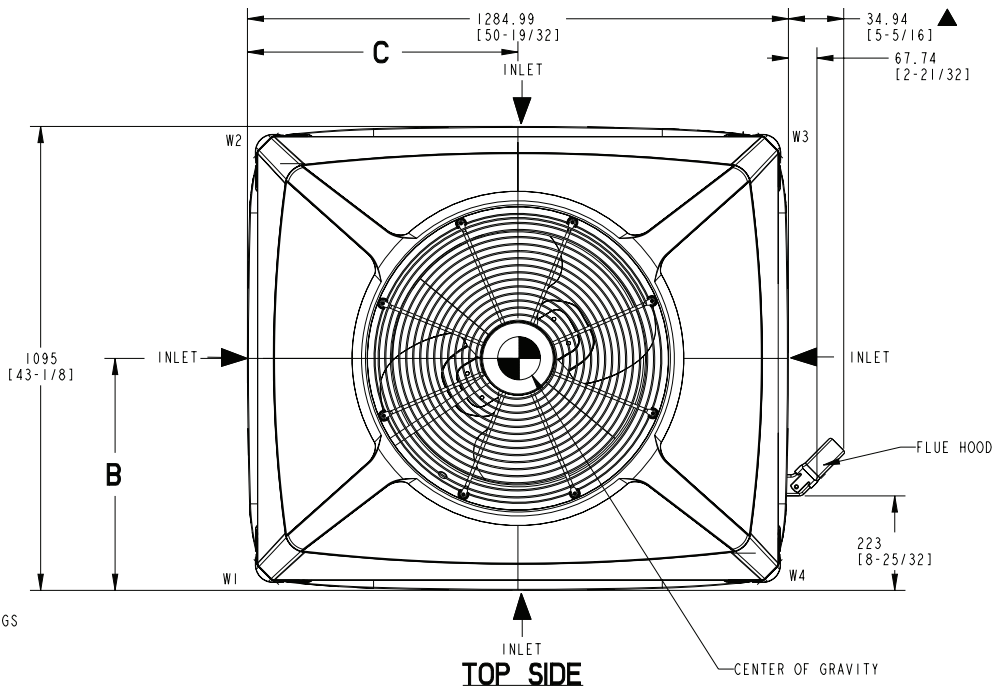
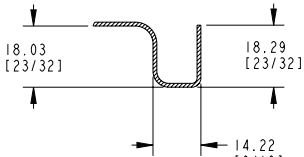

LEFT SIDE

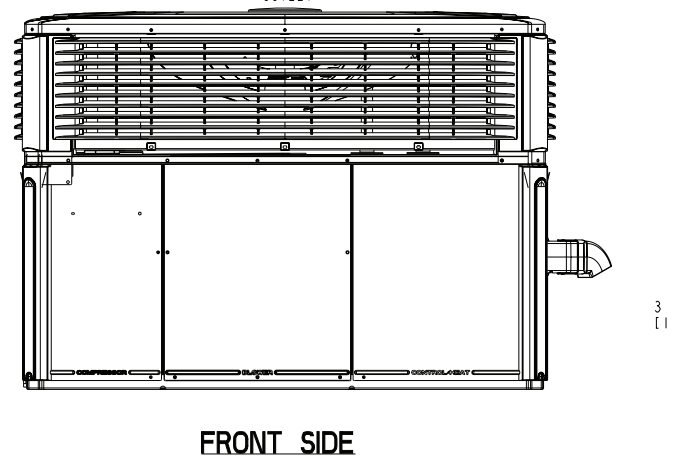

FRONT SIDE

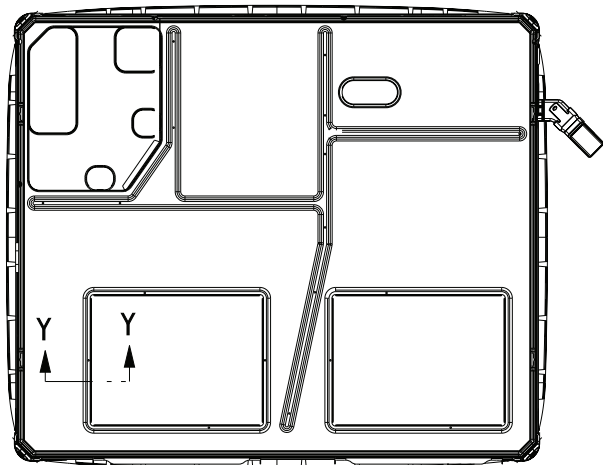

BOTTOM SIDE

DWG NO. D673947G01_REV C

4YCZ6024A (1 of 3)

Dimensional Data

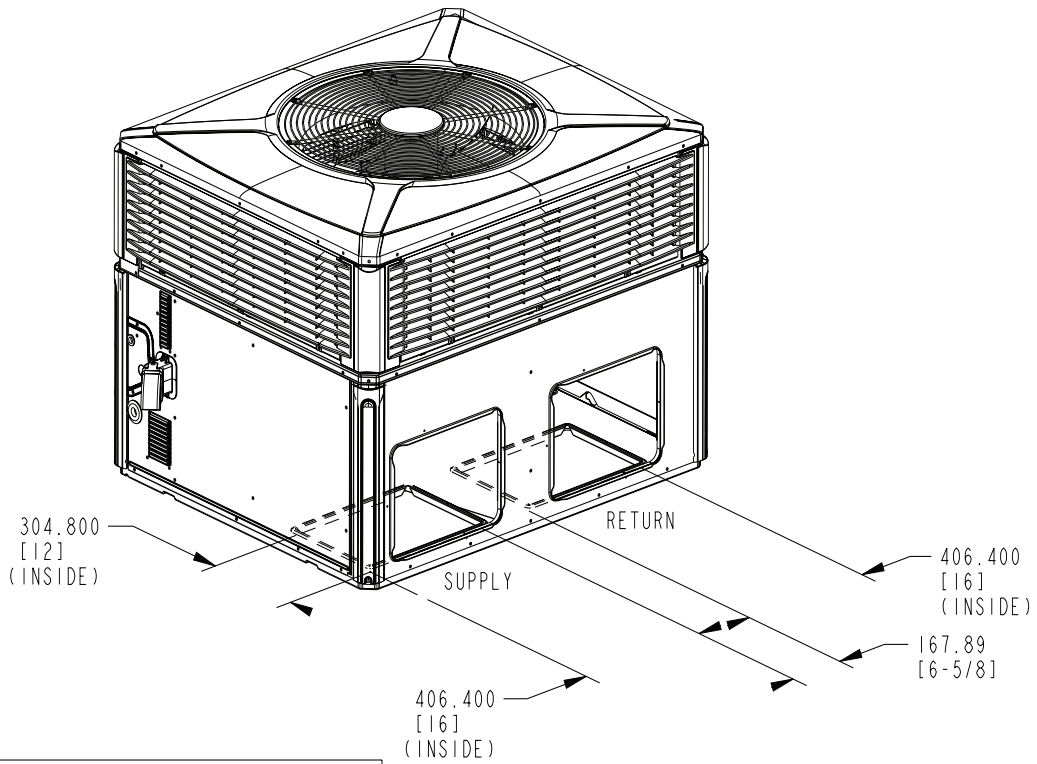

RECOMMENDED SERVICE CLEARANCE MM/IN.		
		WITH ECONOMIZER
BACK SIDE	304.8 [12]	762.0 [30]
LEFT SIDE	762.0 [30]	914.4 [36]
RIGHT SIDE	914.4 [36]	-
FRONT SIDE	1066.8 [42]	-

BOTTOM DUCT OPENINGS

CLEARANCE TO COMBUSTIBLE MATERIAL MM/IN.	
BOTTOM	0
BACK SIDE	25.4 [1]
LEFT SIDE	152.4 [6]
RIGHT SIDE	304.8 [12]
FRONT SIDE	304.8 [12]
TOP	914.4 [36]

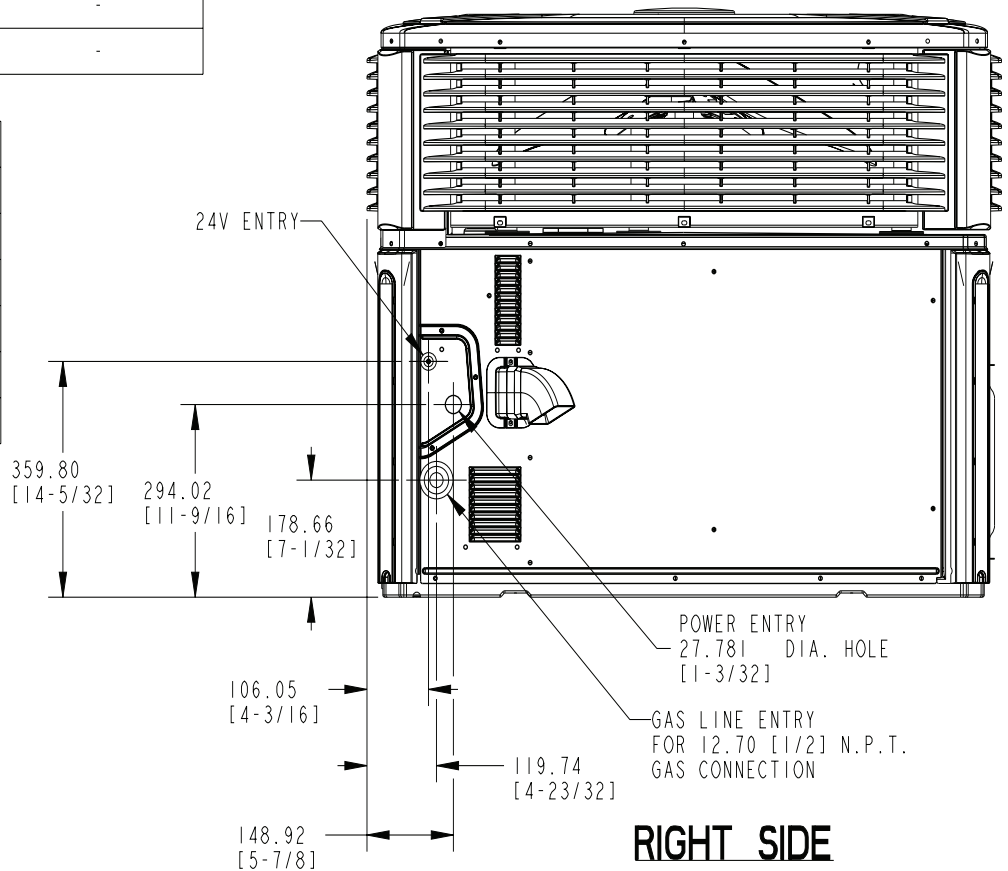

RIGHT SIDE

4YCZ6024A (2 of 3)

Dimensional Data

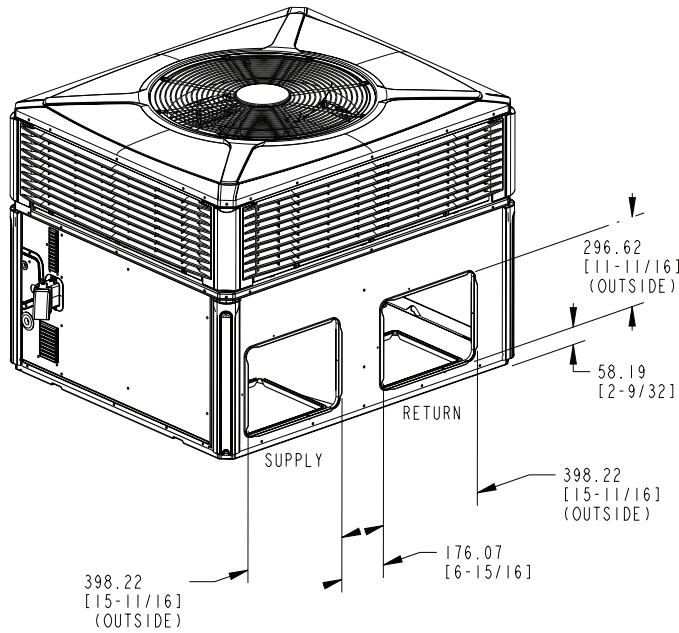

BACK DUCT OPENINGS

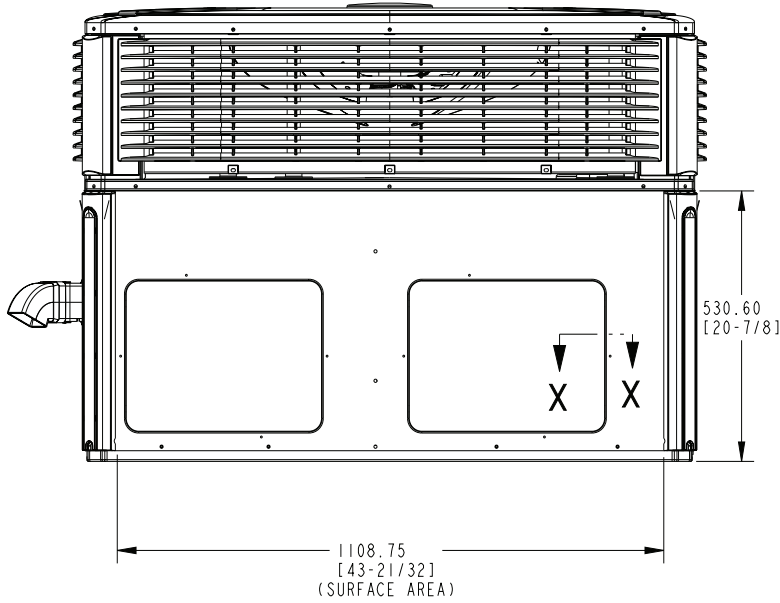

BACK SIDE

MODEL	HEIGHT MM/IN.	APPROX. CORNER WEIGHT - KG/LBS				SHIPPING WEIGHT KG/LBS	TOTAL UNIT WEIGHT KG/LBS	CENTER OF GRAVITY MM/IN.	
	A	W1	W2	W3	W4			B	C
▲ 4YCZ6024	903.29 [35-3/8]	60.3 [133]	38.1 [84]	26.8 [59]	42.6 [94]	199.6 [440]	167.8 [370]	406.0 [16.0]	533.4 [21.0]
4YCY4036/4YCY6036 (075)	949.99 [37-3/8]	60.3 [133]	36.3 [80]	30.4 [67]	50.3 [111]	221.6 [488]	178.0 [392]	388.6 [15.3]	558.8 [22.0]
4YCY4036/4YCY6036 (096)		61.2 [135]	36.7 [81]	30.8 [68]	51.3 [113]	223.8 [493]	180.1 [397]	388.6 [15.3]	558.8 [22.0]
▲ 4DCY4024 (064)	903.29 [35-3/8]	60.8 [134]	38.1 [84]	31.3 [69]	48.5 [107]	218.4 [481]	174.8 [385]	398.8 [15.7]	546.1 [21.5]
4DCY4030 (075)		62.1 [137]	37.2 [82]	30.4 [67]	50.3 [111]	221.6 [488]	178.0 [392]	386.1 [15.2]	558.8 [22.0]
▲ 4DCY4036/4DCZ6036 (075)	949.99 [37-3/8]	62.1 [137]	37.2 [82]	30.4 [67]	50.3 [111]	221.6 [488]	178.0 [392]	386.1 [15.2]	558.8 [22.0]
▲ 4YCY5024(060)	903.29 [35-3/8]	57.8 [128]	36.6 [81]	25.9 [57]	40.7 [90]	192.8 [425]	161.0 [355]	401.3 [15.8]	546.1 [21.5]
4YCY5030(070)	949.99 [37-3/8]	62.7 [138]	39.6 [87]	28.1 [62]	44.2 [97]	206.4 [455]	174.6 [385]	388.6 [15.3]	558.8 [22.0]
4YCY5036(070)	949.99 [37-3/8]	63.5 [140]	40.2 [89]	28.5 [63]	44.7 [99]	208.7 [460]	176.9 [390]	388.6 [15.3]	558.8 [22.0]
4YCY5036(090)	949.99 [37-3/8]	64.4 [142]	40.7 [90]	28.8 [64]	45.3 [100]	210.9 [465]	179.2 [395]	388.6 [15.3]	558.8 [22.0]

4YCZ6024A (3 of 3)

Dimensional Data

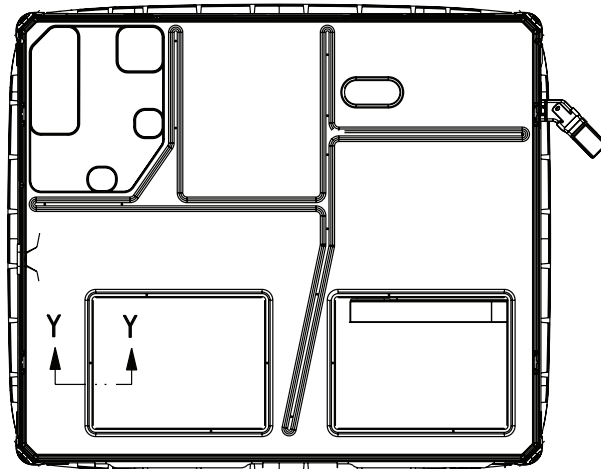
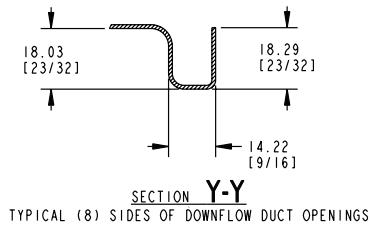
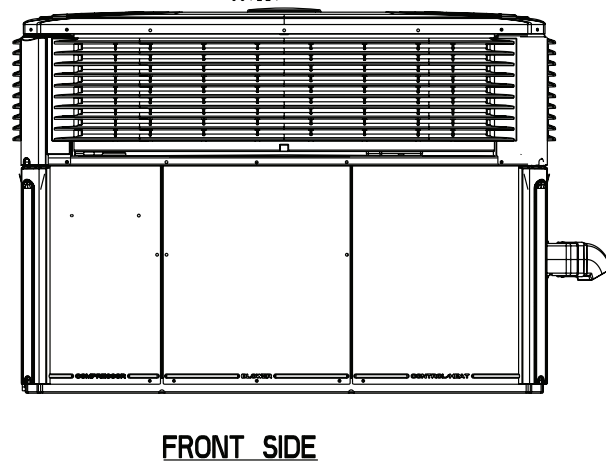
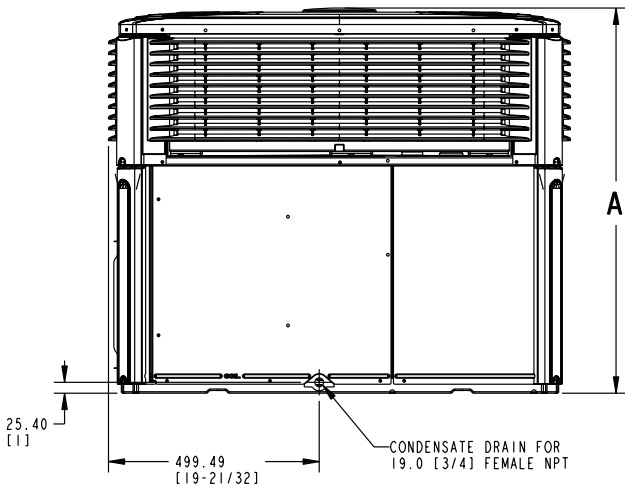
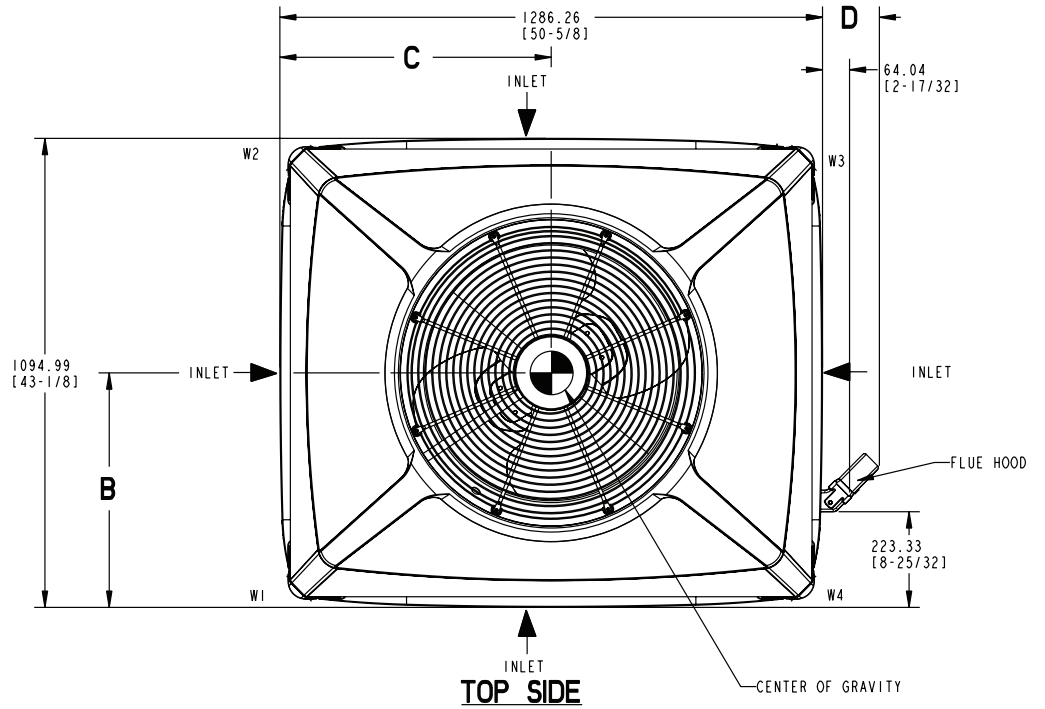

4YCZ6036A (1 of 3)

Dimensional Data

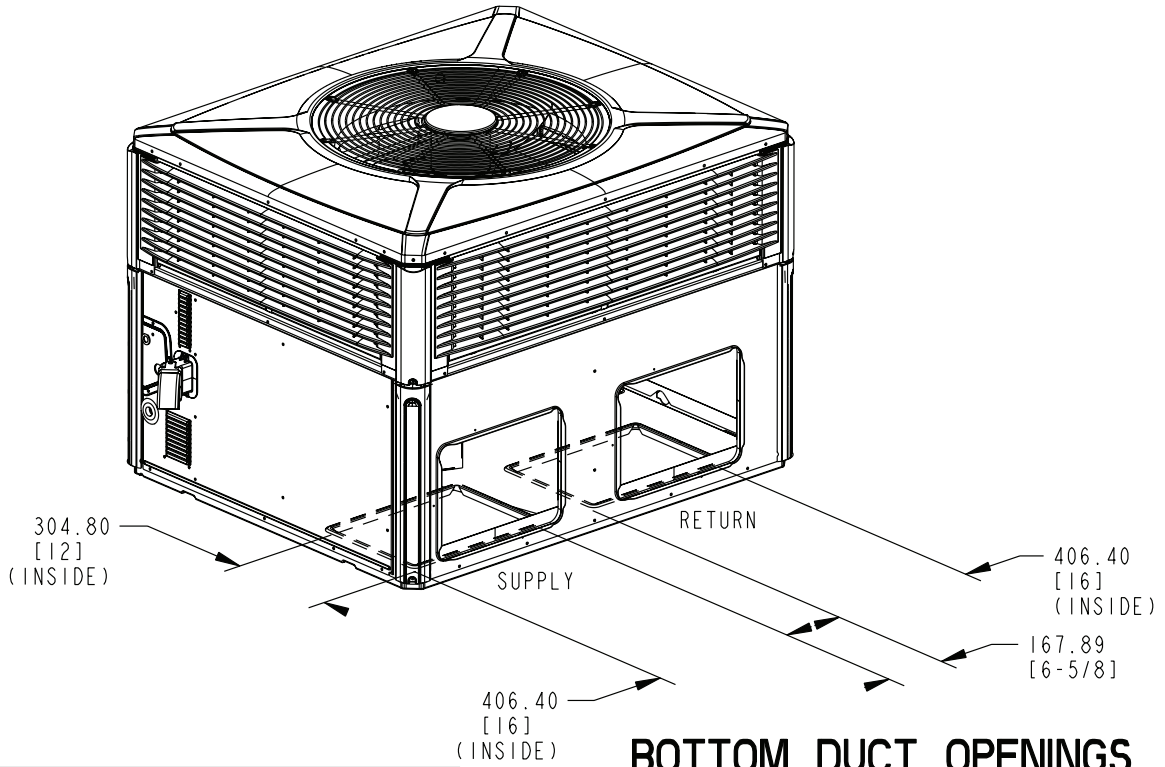

BOTTOM DUCT OPENINGS

RECOMMENDED SERVICE CLEARANCE MM/IN.		
		WITH ECONOMIZER
BACK SIDE	304.8 [12]	762.0 [30]
LEFT SIDE	762.0 [30]	914.4 [36]
RIGHT SIDE	914.4 [36]	-
FRONT SIDE	1066.8 [42]	-

CLEARANCE TO COMBUSTIBLE MATERIAL MM/IN.	
BOTTOM	0
BACK SIDE	25.4 [1]
LEFT SIDE	152.4 [6]
RIGHT SIDE	304.8 [12]
FRONT SIDE	304.8 [12]
TOP	914.4 [36]

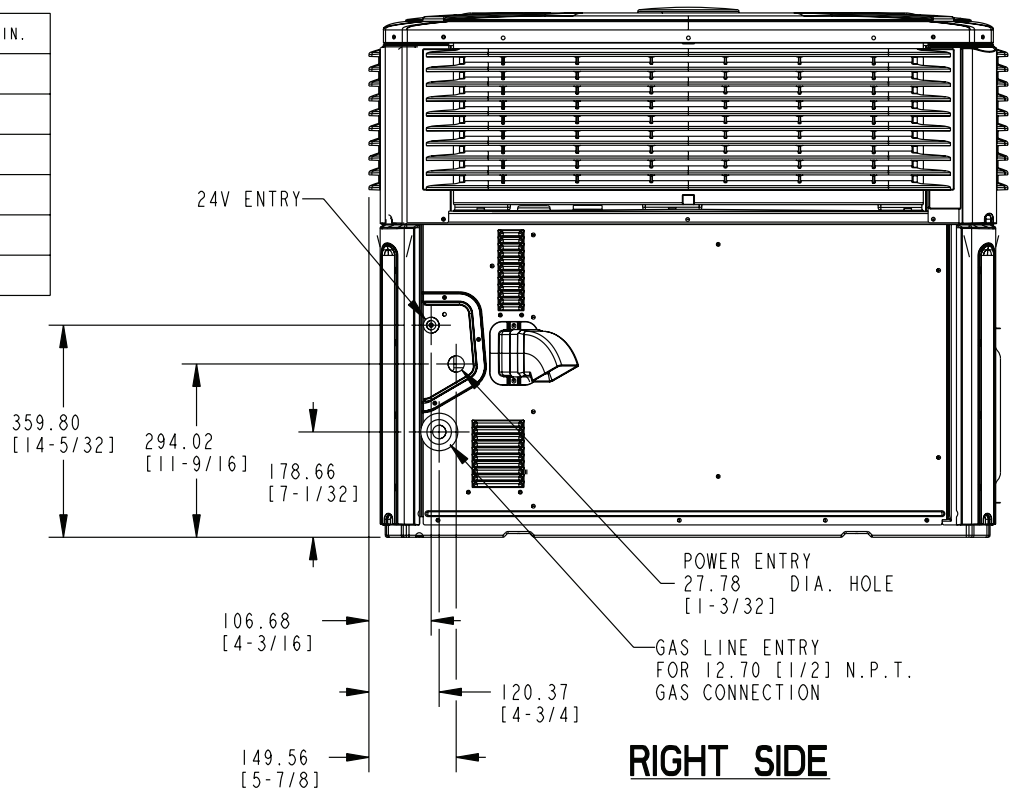

RIGHT SIDE

4YCZ6036A (2 of 3)

Dimensional Data

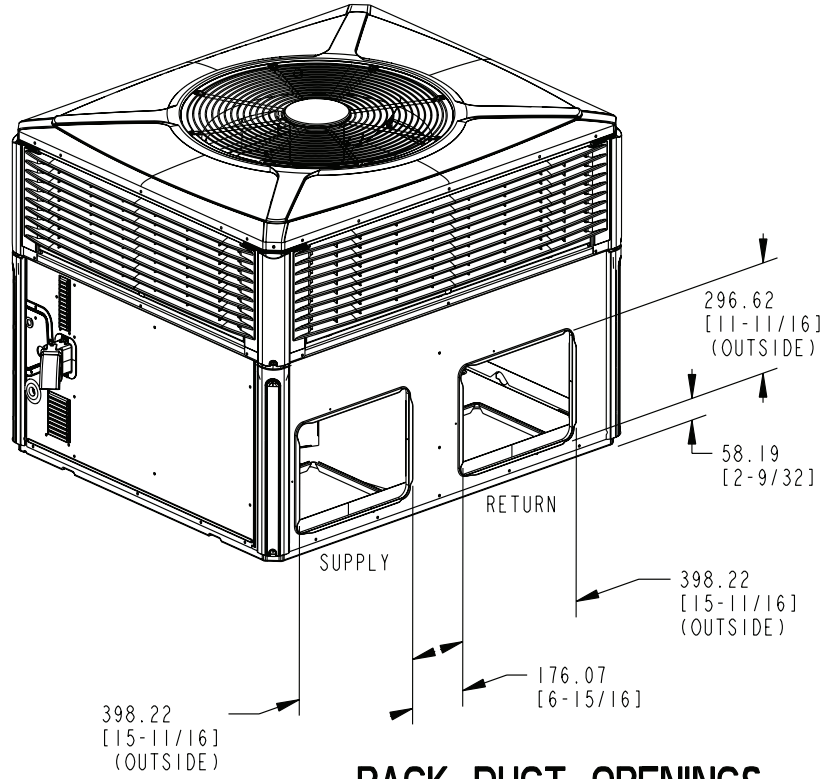

BACK DUCT OPENINGS

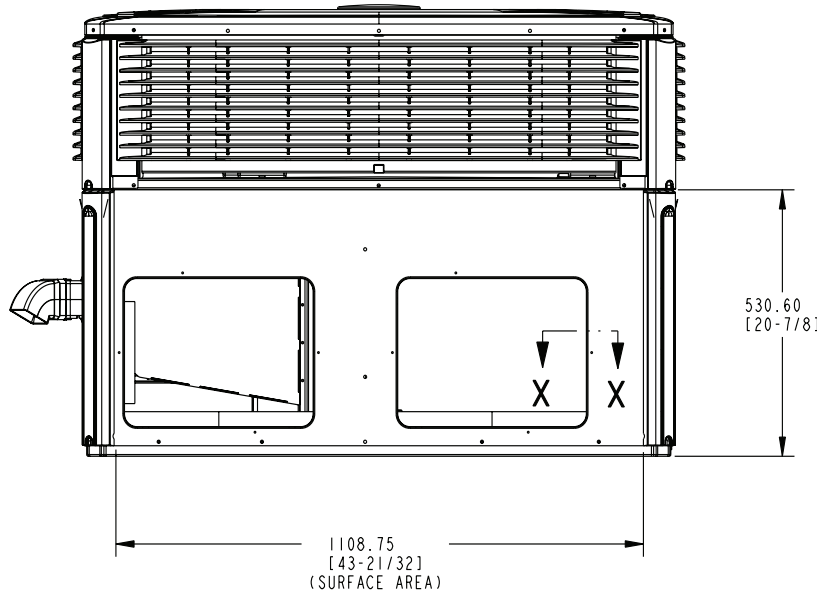

BACK SIDE

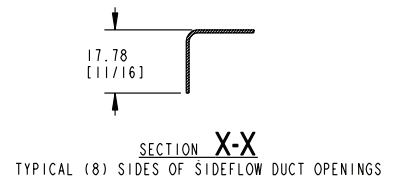

MODEL	HEIGHT MM/IN.	FLUE HOOD W/BRKT MM/IN.	APPROX. CORNER WEIGHT - KG/LBS				SHIPPING WEIGHT KG/LBS	TOTAL UNIT WEIGHT KG/LBS	CENTER OF GRAVITY MM/IN.	
	A		D	W1	W2	W3			W4	B
4CY4024 (060)	903.29 [35-9/16]	-	59.0 [130]	37.2 [82]	31.3 [69]	48.5 [107]	218.4 (481)	174.8 [385]	401.3 [15.8]	546.1 [21.5]
4CY4030 (070)										
4CY4036/4YC6036 (070)	949.99 [37-3/8]	117.86 [4-5/8]	60.3 [133]	36.3 [80]	30.4 [67]	50.3 [111]	221.6 (488)	178.0 [392]	388.6 [15.3]	558.8 [22.0]
4CY4036/4YC6036 (090)			61.2 [135]	36.7 [81]	30.8 [68]	51.3 [113]	223.8 (493)	180.1 [397]	388.6 [15.3]	558.8 [22.0]
4DCY4024 (060)	903.29 [35-9/16]	-	60.8 [134]	38.1 [84]	31.3 [69]	48.5 [107]	218.4 (481)	174.8 [385]	398.8 [15.7]	546.1 [21.5]
4DCY4030 (070)										
4DCY4036/4DCZ6036 (070)	949.99 [37-3/8]	117.86 [4-5/8]	62.1 [137]	37.2 [82]	30.4 [67]	50.3 [111]	221.6 (488)	178.0 [392]	386.1 [15.2]	558.8 [22.0]

4YCZ6036A (3 of 3)

Dimensional Data

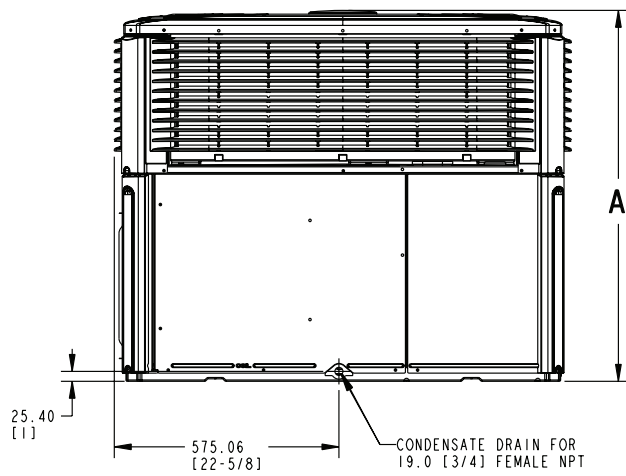
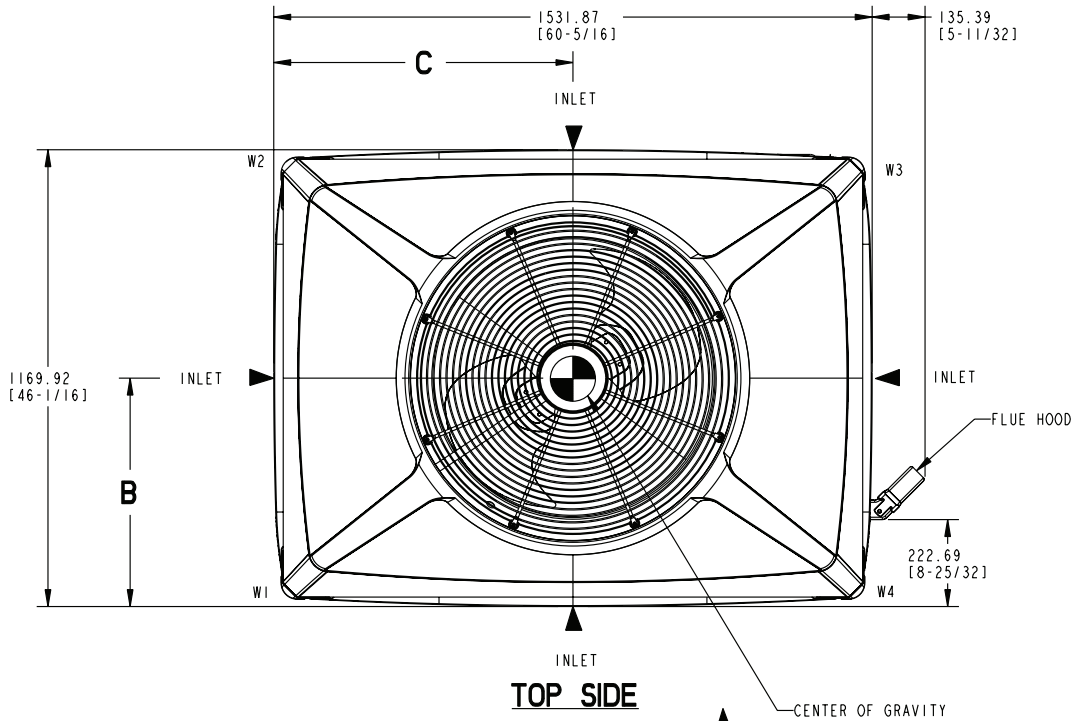

LEFT SIDE

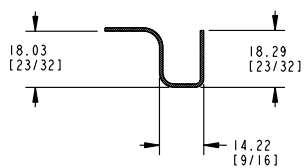
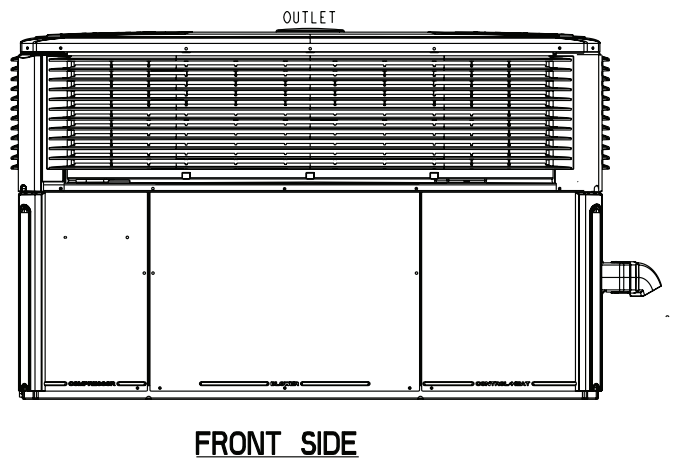

SECTION Y-Y
 TYPICAL (8) SIDES OF DOWNFLOW DUCT OPENINGS

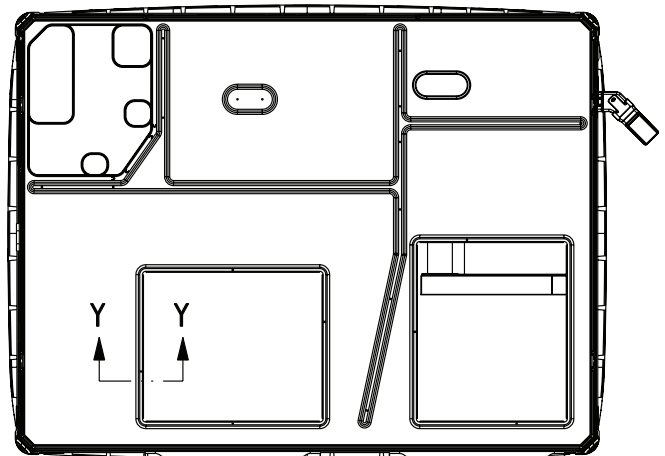

4YCZ6048A through 4YCZ6060A (1 of 3)

Dimensional Data

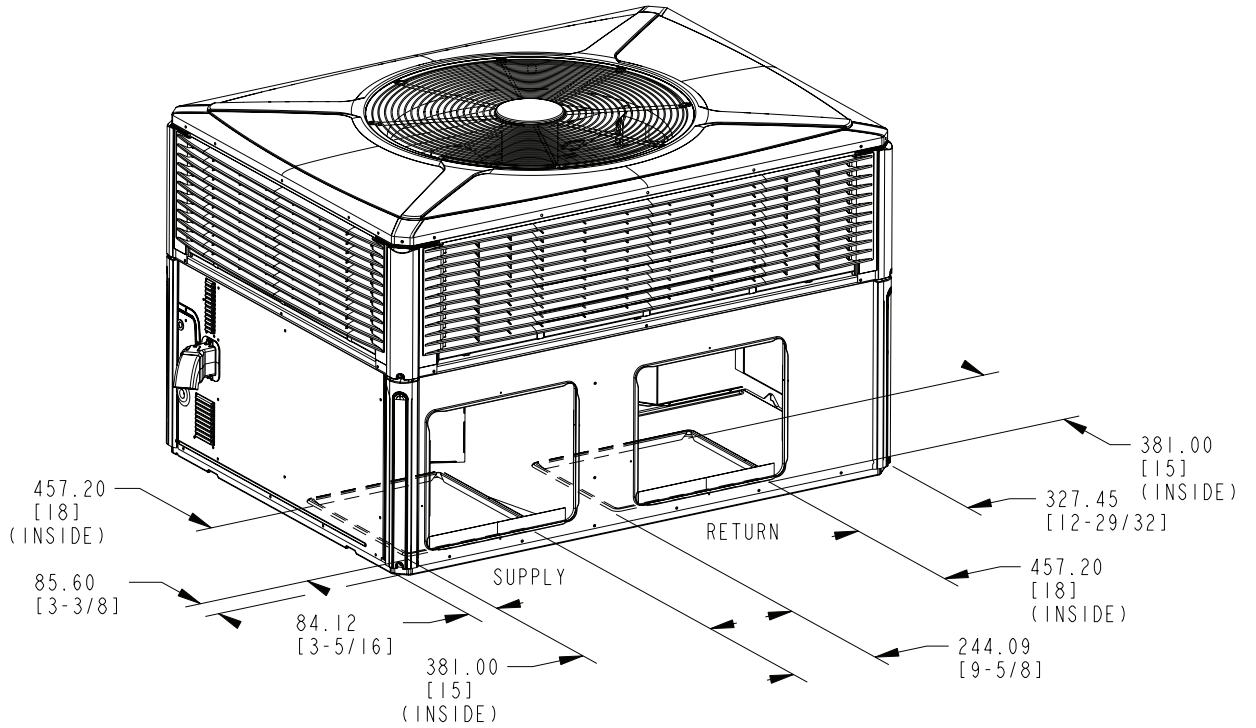

BOTTOM DUCT OPENINGS

RECOMMENDED SERVICE CLEARANCE MM/IN.		
		WITH O.A. DAMPER/ECON.
BACK SIDE	304.8 [12]	762.0 [30]
LEFT SIDE	914.4 [36]	1066.8 [42]
RIGHT SIDE	914.4 [36]	-
FRONT SIDE	1066.8 [42]	-

CLEARANCE TO COMBUSTIBLE MATERIAL MM/IN.	
BOTTOM	0
BACK SIDE	25.4 [1]
LEFT SIDE	152.4 [6]
RIGHT SIDE	304.8 [12]
FRONT SIDE	304.8 [12]
TOP	914.4 [36]

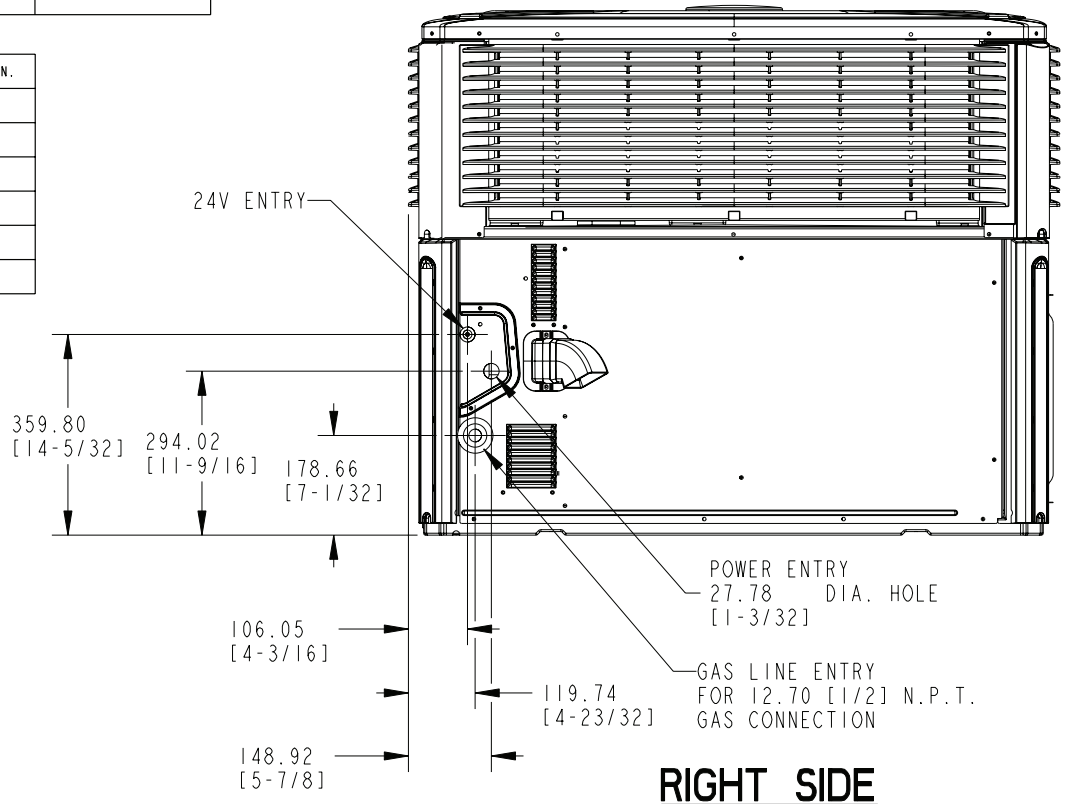

RIGHT SIDE

4YCZ6048A through 4YCZ6060A (2 of 3)

Dimensional Data

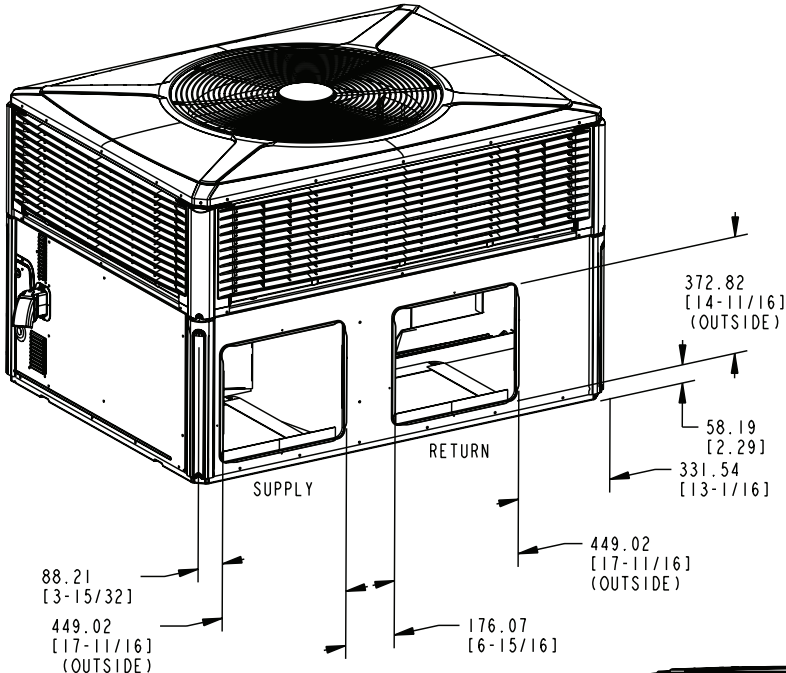

BACK DUCT OPENINGS

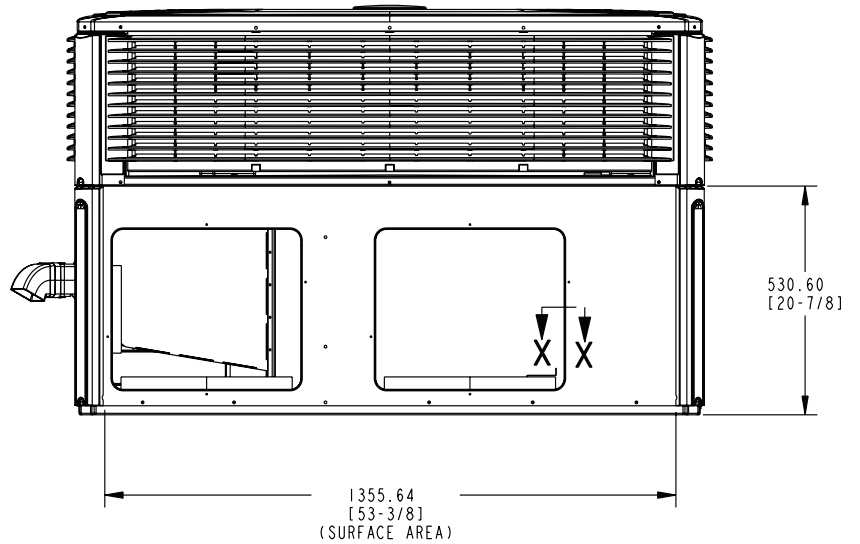
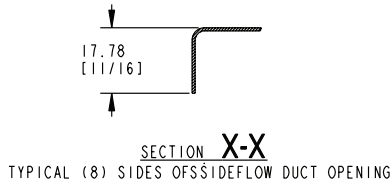

BACK SIDE

MODEL	HEIGHT MM/IN.	APPROX. CORNER WEIGHT - KG/LBS				SHIPPING WEIGHT KG/LBS	TOTAL UNIT WEIGHT KG/LBS	CENTER OF GRAVITY MM/IN.	
		A	W1	W2	W3			W4	B
4CY4042C (090)	949.33 [37-3/8]	75.3 [166]	50.3 [111]	45.4 [100]	67.6 [149]	296.5 [653]	238.1 [525]	444.5 [17.5]	698.5 [27.5]
4CY4048C (090)	949.33 [37-3/8]	77.1 [170]	52.2 [115]	47.2 [104]	69.4 [153]	303.4 [669]	245.9 [541]	444.5 [17.5]	698.5 [27.5]
4CY4048C (115)	949.33 [37-3/8]	77.1 [170]	52.2 [115]	47.2 [104]	69.4 [153]	303.4 [669]	245.9 [541]	444.5 [17.5]	698.5 [27.5]
4CY4060C (115)	1050.93 [41-3/8]	82.1 [181]	46.3 [102]	43.1 [95]	76.7 [169]	306.9 [676]	248.6 [548]	401.3 [15.8]	711.2 [28.0]
4DCY4042C (090)	949.33 [37-3/8]	77.1 [170]	51.3 [113]	45.4 [100]	67.6 [149]	296.5 [653]	238.4 [525]	442.0 [17.4]	698.5 [27.5]
4DCY4048C (090)	949.33 [37-3/8]	78.9 [174]	53.0 [117]	47.2 [104]	69.4 [153]	306.6 [676]	248.5 [548]	442.0 [17.4]	698.5 [27.5]
4DCY4060C (115)	1050.93 [41-3/8]	83.9 [185]	47.2 [104]	43.1 [95]	76.7 [169]	306.9 [676]	248.8 [548]	398.8 [15.7]	711.2 [28.0]
4YCZ6048C (090)	1050.93 [41-3/8]	75.7 [167]	50.8 [112]	45.8 [101]	68.5 [151]	299.2 [659]	240.9 [531]	444.5 [17.5]	698.5 [27.5]
4YCZ6048C (115)		81.6 [180]	46.3 [102]	42.2 [93]	73.5 [162]	301.6 [665]	243.6 [537]	419.1 [16.5]	706.1 [27.8]
4YCZ6060C (115)	1050.93 [41-3/8]	82.1 [181]	46.3 [102]	43.1 [95]	76.7 [169]	306.9 [676]	248.6 [548]	401.3 [15.8]	711.2 [28.0]
4DCZ6048C (090)	1050.93 [41-3/8]	81.6 [180]	46.3 [102]	42.2 [93]	73.5 [162]	301.6 [665]	243.6 [537]	419.1 [16.5]	706.1 [27.8]
4DCZ6060C (115)	1050.93 [41-3/8]	83.9 [185]	47.2 [104]	43.1 [95]	75.7 [169]	306.9 [676]	248.8 [548]	398.8 [15.7]	711.2 [28.0]

4YCZ6048A through 4YCZ6060A (3 of 3)

Mechanical Specifications

General

All units shall be factory assembled, piped, internally wired and fully charged with refrigerant. All units shall be designed to operate at outdoor ambient temperatures as high as 115°F. Cooling capacities shall be rated in accordance with A.H.R.I. standards. The heating/cooling unit design is certified to ANSI 221.47/CSA 2.3, specifically for outdoor applications using natural gas or propane. All units shall be designed for outdoor rooftop or ground level installation. Unit casing is constructed of heavy gauge, galvanized steel and painted with a weather-resistant powder paint.

Shipped for horizontal application, convertible to downflow.

Casings

All panels shall be heavy gauge steel, gasketed and insulated. Foil-faced insulation shall be in the heat exchanger section. Foil-faced insulation shall be in the evaporator section. Base pan shall be heavy gauge steel. **WEATHERGUARD™** exterior corrosion resistant screws shall be used for added resistance to rust and corrosion.

Controls

Refrigeration cycle controls shall include condenser fan, evaporator fan and compressor contactors. Compressors shall be equipped with a combination internal winding thermostat/current overload. Internal high pressure relief shall also be provided.

Refrigeration System

Compressors —

The Duration™ two-stage compressor features internal over temperature and pressure protector, total dipped hermetic motor. Other features include: centrifugal oil pump, and low vibration and noise.

Evaporator Coil — (2-4 Ton Models)

All aluminum micro channel, extruded tubes, mechanically bonded to aluminum fins and factory pressure and leak tested at 480-650 psig. All units have TXV to control refrigerant flow.

(5 Ton Models) Internally enhanced 3/8-inch OD seamless copper tubing mechanically bonded to aluminum fins, factory pressure and leak tested at 480-650 psig. All units have TXV to control refrigerant flow.

**American Standard
Heating & Air Conditioning**
6200 Troup Highway
Tyler, TX 75707

Condenser Coil —

The **Spine Fin™** condenser coil shall be continuously wrapped, corrosion resistant all aluminum with minimum brazed joints. This coil is 3/8 inch OD seamless aluminum tubing glued to a continuous aluminum fin. Coils are lab tested to withstand 2,000 pounds of pressure per square inch. The outdoor coil provides low airflow resistance and efficient heat transfer. The coil is protected on all four sides by louvered panels.

Indoor Air Fan — Direct-drive, forward-curved, centrifugal wheel in a Composite **Vortica®** Blower housing. Motor shall have thermal overload protection. Permanently lubricated motor bearings. Motor/blower assembly isolated from unit with rubber mounts.

Condenser Fan — Direct-drive, draw through propeller type. Weather-proofed permanent split capacitor fan motor shall have built-in thermal overload and permanently lubricated motor bearings.

Low Ambient — Standard refrigerant system operation down to 55°F. Low ambient accessory required for operation to 0°F ambient condition.

Gas-Fired Heating System — Models shall provide completely assembled, wired and piped gas fired heating systems within unit. Design certified by UL, specifically for outdoor application. Threaded gas connection on the unit.

Electronic Ignition System — Main burner is lit each time thermostat calls for gas heat. Flame sensor proves flame and keeps the main burners on. Should a loss of flame occur, the main valve closes and the spark recurs within 0.8 second. When thermostat is satisfied, main burner is extinguished.

Forced Combustion Blower — Insures flame stability under varying wind conditions. Gives higher combustion efficiency and location flexibility.

Heat Exchanger — stainless steel tubes. Free floating design.

Burners — stainless steel. Multi-port inshot.

Accessories (U.S. Domestic Models)

Roof Curb — The roof curb shall be designed to mate with the unit and provide support and complete weather-tight installation when properly installed. Curb shall ship knocked down for field assembly, and include wood nailer strips.

Modulating Economizer — This accessory shall be field installed and be composed of the following items: 0-100% fresh air damper, damper drive motor fixed dry bulb enthalpy control, and low voltage polarized plug for electrical connections. Solid state enthalpy or differential enthalpy control is optional. Economizer operations shall be controlled by the preset position of the enthalpy control. A barometric relief damper shall be standard with the economizer and provide a pressure operated damper that shall be gravity closing and prohibit entrance of outside air on equipment "off" cycle.

Manual Fresh Air Hood

Manual outside air provides a fixed outside air quantity from 0 to 25 percent. Includes hood and birdscreen.

Low Ambient Control

Control allows cycling of compressor under low ambient cooling conditions. Required for cooling operation to 0°F.

Propane Gas Conversion Kit — For conversion from natural gas to LP gas.

