

TAG: _____

SPECIFICATION

4 Ton Split System Cooling — 1 Ph 4A7A7048B

NOTE: All dimensions are in mm/inches.

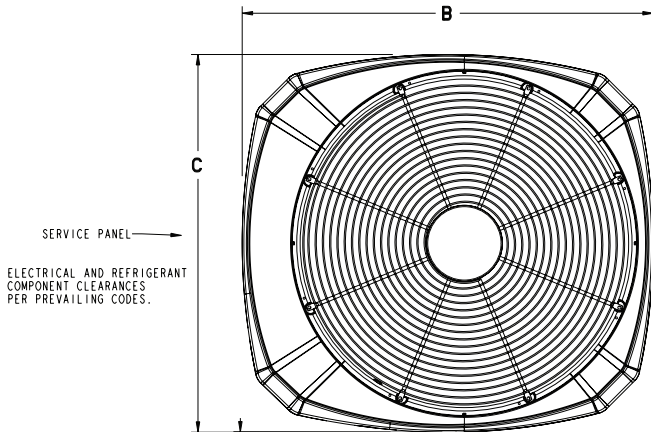

SERVICE PANEL
ELECTRICAL AND REFRIGERANT
COMPONENT CLEARANCES
PER PREVAILING CODES.

TOP DISCHARGE AREA SHOULD BE
UNRESTRICTED FOR AT LEAST 1524 (5 FEET)
ABOVE UNIT. UNIT SHOULD BE PLACED SO ROOF
RUN-OFF WATER DOES NOT POUR DIRECTLY ON UNIT,
AND SHOULD BE AT LEAST 305 (12") FROM WALL AND
ALL SURROUNDING SHRUBBERY ON TWO SIDES.
OTHER TWO SIDES UNRESTRICTED.

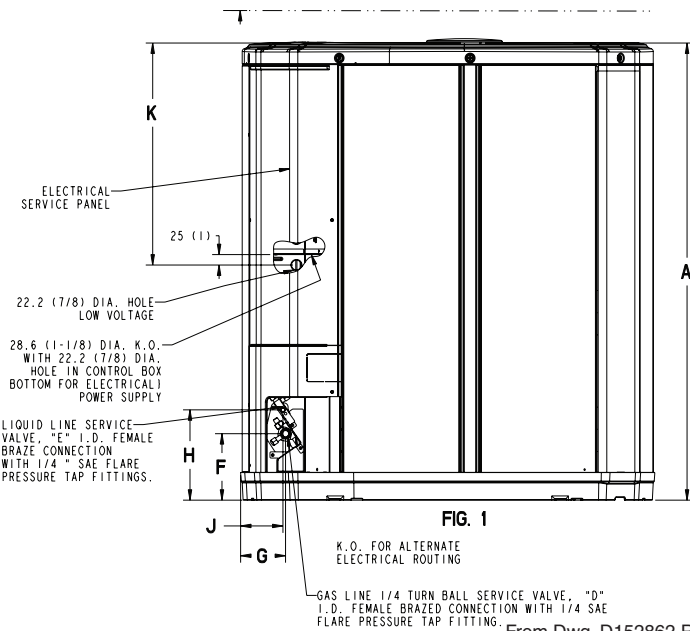

FIG. 1

K.O. FOR ALTERNATE
ELECTRICAL ROUTING
GAS LINE 1/4 TURN BALL SERVICE VALVE, "D"
1/2" FEMALE BRAZED CONNECTION WITH 1/4 SAE
FLARE PRESSURE TAP FITTING. From Dwg. D152862 Rev. 26

MODELS	BASE	A	B	C	D	E	F	G	H	J	K
4A7A7048B	4	1147 (45-1/8)	946 (37-1/4)	870 (34-1/4)	7/8	3/8	152 (6)	98 (3-7/8)	219 (8-5/8)	86 (3-3/8)	813 (32)

Product Specifications

OUTDOOR UNIT ①②	4A7A7048B1000A
POWER CONNS. — V/PH/HZ ③	208/230/1/60
MIN. BRCH. CIR. AMPACITY	28
BR. CIR. PROT. RTG. — MAX. (AMPS)	45
COMPRESSOR	DURATION™ - SCROLL
NO. USED - NO. STAGES	1 - 2
VOLTS/PH/HZ	230/1/60
R.L. AMPS ⑦ - L.R. AMPS	20.4 - 122
FACTORY INSTALLED	
START COMPONENTS ⑧	NO
INSULATION/SOUND BLANKET	NO
COMPRESSOR HEAT	NO
OUTDOOR FAN	PROPELLER
DIA. (IN.) - NO. USED	27.6 - 1
TYPE DRIVE - NO. SPEEDS	DIRECT - 1
CFM @ 0.0 IN. W.G. ④	4400
NO. MOTORS - HP	1 - 1/3
MOTOR SPEED R.P.M.	825
VOLTS/PH/HZ	208/230/1/60
F.L. AMPS	2.8
OUTDOOR COIL — TYPE	SPINE FIN™
ROWS - F.P.I.	1 - 24
FACE AREA (SQ. FT.)	30.79
TUBE SIZE (IN.)	3/8
REFRIGERANT	R-410A
LBS. — R-410A (O.D. UNIT) ⑤	11 LBS.- 15 OZ.
FACTORY SUPPLIED	YES
LINE SIZE - IN. O.D. GAS ⑥	7/8
LINE SIZE - IN. O.D. LIQ. ⑥	3/8
CHARGING SPECIFICATION	10°F
SUBCOOLING	
DIMENSIONS	H X W X D
CRATED (IN.)	51 X 35.1 X 38.7
WEIGHT	
SHIPPING (LBS.)	296
NET (LBS.)	259

① Certified in accordance with the Air-Source Unitary Air-conditioner Equipment certification program, which is based on AHRI standard 210/240. In order to achieve AHRI standard rating, the indoor fan time delay on the comfort control must be enabled.

② Rated in accordance with ARI standard 270.

③ Calculated in accordance with Natl. Elec. Codes. Use only HACR circuit breakers or fuses.

④ Standard Air — Dry Coil — Outdoor

⑤ This value approximate. For more precise value see unit nameplate.

⑥ Max. linear length 60 ft.; Max. lift - Suction 25 ft.; Max. lift - Liquid 25 ft. For greater length consult refrigerant piping software Pub. No. 32-3312-0* (* denotes latest revision).

⑦ This value shown for compressor RLA on the unit nameplate and on this specification sheet is used to compute minimum branch circuit ampacity and max. fuse size. The value shown is the branch circuit selection current.

⑧ No means no start components. Yes means quick start kit components. PTC means positive temperature coefficient starter.

Sound Power Level

Model	A-Weighted Sound Power Level [dB(A)]	Full Octave Sound Power [dB]							
		63 Hz	125 Hz	250 Hz	500 Hz	1000 Hz	2000 Hz	4000 Hz	8000 Hz
4A7A7048B	73	70	67	68	66	63	56	53	49

Note: Rated in accordance with AHRI Standard 270-2008

Mechanical Specification Options

General

The 4A7A7 is fully charged from the factory for matched indoor section and up to 15 feet of piping. This unit is designed to operate at outdoor ambient temperatures as high as 115°F. Cooling capacities are matched with a wide selection of air handlers and furnace coils that are AHRI certified. The unit shall be certified to UL 1995. Exterior is designed for outdoor application.

Casing

Unit casing is constructed of heavy gauge, G60 galvanized steel and painted with a weather-resistant powder paint on all louvers and panels. Corrosion and weatherproof CMBP-G30 DuraBase™ base.

Refrigerant Controls

Refrigeration system controls include condenser fan, compressor contactor and high pressure switch. High and low pressure controls are inherent to the compressor. A factory installed liquid line drier is standard.

Compressor

The Duration® 2-stage compressor features internal over temperature and pressure protection and hermetic motor. Other features include: roto lock suction and discharge refrigerant connections, centrifugal oil pump and modular plugs for electrical connections.

Condenser Coil

The outdoor coil provides low airflow resistance and efficient heat transfer. The coil is protected on all four sides by louvered panels.

Low Ambient Cooling

As manufactured, this unit has a cooling capability to 55°F. For low ambient cooling below 55° see Application Guide APP-APG014-EN.

