

## GENERAL

The VL\* Series is designed for permanent vertical installations in a closet or recessed in the wall. Units of three tons and less can be installed with front return through the option return air filter grille. An optional wall hanging kit is available. Air conditioning and heat pump coils are available to match specific manufacturer's outdoor units. Various models are available for applications up to three tons of nominal cooling capacity. The VL model is 18" W x 18" D x 36<sup>3/4</sup>" H with up to 2.5 tons nominal capacity, and available up to 10 kW electric resistance heat.

The VLD model is 20" W x 23" D x 40" H, the VLL model is 24.00" W x 24.00" D x 40" H. The VLD and the VLL models are available up to 3 tons of nominal capacity and up to 15 kW electric resistance heat. Cabinets are fully insulated and constructed from embossed galvanized steel.

Front panels are painted for an attractive appearance. Time delay fan relays are standard on all models. All models are pre-wired for heat pump application. Flowrator refrigerant metering devices are standard. Thermal expansion valves or check valves are available factory or field installed. All models are 208/230 VAC single phase 60 Hz and are provided with a 24 volt control transformer.

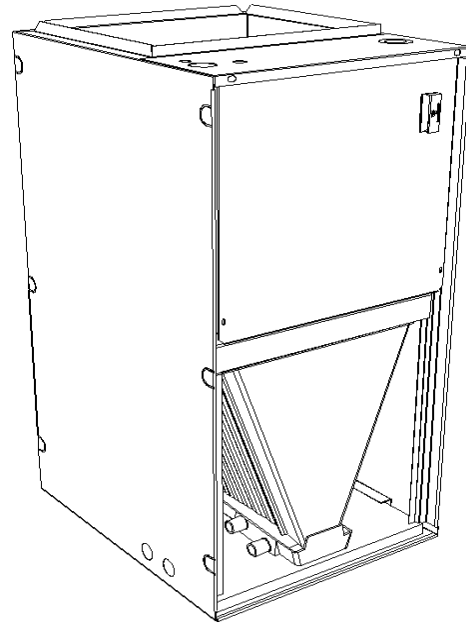

**! WARNING:** Due to possible damage to equipment or personal injury, installation, service and maintenance should only be performed by a trained, qualified person. Consumer service is recommended only for filter replacement.

Installation of this unit shall be made in accordance with the National Electric Code, NFPA No. 90A and 90B, and any other local codes or utilities requirements.

**! WARNING:** HAZARDOUS VOLTAGE - Ensure all power is disconnected before installing or servicing this unit. More than one disconnect device may be required to de-energize the equipment. Hazardous voltage can cause severe personal injury. Make certain all panels are in place before operating this unit.

## UNPACKING

Carefully unpack the unit and inspect the contents for damage. If any damage is found at the time of delivery proper notification and claims should be made with the carrier who delivered the unit.

Check the unit rating plate to insure model number and voltage, plus any kits agree with what you ordered. The supplier should be notified immediately of any discrepancy or parts shortage.

# INSTALLATION GUIDE

## Location

The blower coil unit should be centrally located and may be installed in a closet or recessed mounted in a wall with 0" clearance from any side, front, rear, or duct work. The unit must be installed in a level position to ensure proper condensation drainage. Make sure the unit is level in both directions within 1/8" on either side.

When the unit is installed in a closet or utility room, the room should be large enough and have an opening to allow replacement of the unit. All servicing is done from the front and a clearance of 24" is needed for service unless the closet door aligns with the front of the furnace. The unit is designed to sit on a platform or hang on the wall with the supplied mounting tabs punched out in the back cabinet wall.

If the unit is going to be installed with the return air through the base, remove the lower access door and remove the fiberboard insulation panel from the bottom channel. This channel may be used as a filter rack. A standard 18" x 18" x 1" filter will fit the channel on the VL, a 20" x 20" x 1" filter is required on the VLD model, and a 24" x 24" x 1" filter is required on the VLL model. Be sure to replace the lower access door prior to operating the unit.

If the unit is to hang on the wall, an optional wall mounting kit is required. Carefully follow the instructions in the kit.

When the unit is mounted flush in the wall between studs, the optional return air filter grille panel is required. The unit should be positioned approximately 10" to 12" above the finished floor elevation between the studs of the wall. This will allow proper spacing to trap the primary auxiliary condensate drains. (See fig. A)

Any modifications to existing framing should be accomplished by the general contractor to ensure structural strength is maintained in the structure.

The structural opening in the framing should be 37.25" high and 18.50" wide for the VL model. Rough opening for the VLD model should be 20.50" wide and 40.50" high, and the VLL model should be 24.50" wide and 40.50" high. The unit should be positioned where the front edge of the cabinet is flush with the finished face of the wall.

All service connection openings are recessed away from the front to allow clearance for 3.50" wall framing. Three installation tabs are provided on each side of the unit to facilitate mounting. Bend the tabs out 90° and the tabs will position the unit to allow for 1/2" sheet rock finished walls.

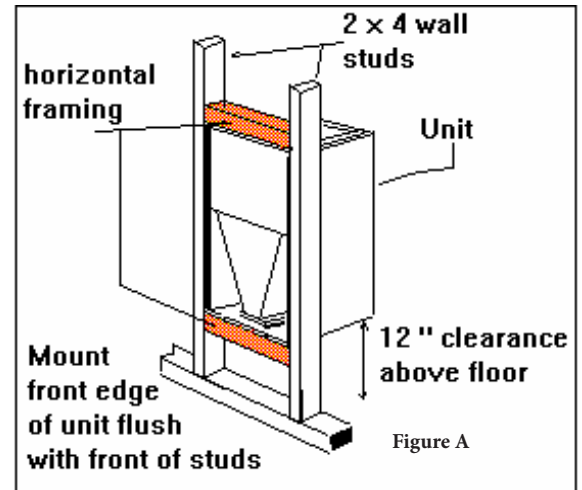

## Duct Work

The duct work should be installed in accordance with the NFPA No. 90A "Installation of Air Conditioning and Ventilating Systems" and No. 90B "Residential Type Warm Air Heating and Air Conditioning Installation."

The duct work should be insulated in accordance with the applicable building code, local utility or other governing body.

## Condensate Drain

The unit is supplied with 3/4" primary and auxiliary condensate drains. Both drains must be trapped outside the unit and piped in accordance with applicable building codes. Do not reduce the drain line size less than the connection size on the drain pan. Condensate should be piped to an open drain or to the outside. All drains must pitch downward away from the unit a minimum of 1/8" per foot of line to ensure proper drainage. For safety it is recommended that a float switch be installed.

# INSTALLATION GUIDE

## Refrigerant Piping

Refrigerant pipe connections are located on the top of the unit. Refrigerant piping external to the unit shall be sized in accordance with the instructions of the manufacturer of the outdoor equipment. When units are recessed in the wall, make certain that piping connections are pressure tested prior to the wall being closed.

## Metering Device

All units are shipped with a checkflow piston installed which is designed for air conditioning or heat pump operation. If your application requires a thermal expansion valve or check expansion valve then it is necessary to remove the piston from the distributor assembly and install the proper metering device. Be sure to follow the instructions in the kit to ensure proper installation.

## Blower

This unit is supplied with a multi-speed motor with a direct drive blower wheel which can obtain various air flows. The unit is shipped with the blower connected for high speed. If a lower blower speed is required, disconnect all power to the unit, remove the black indoor fan motor lead from the fan relay, place an insulated cap on the black lead, remove the insulated cap from the red indoor fan motor lead, place a spade connector on the lead and connect it to the fan relay where the black lead was originally connected. Be sure to check the air flow and the temperature drop across the evaporator coil to ensure that you have sufficient air flow. For ECM option refer to ECM wiring diagram for speed tap placement. (ECM speed taps are 24v to energize) See page 10.

## Wiring

Consult all schematic and pictorial wiring diagrams of this unit and the outdoor equipment to determine compatibility of the wiring connections and to determine specific requirements.

All field wiring to the blower coil should be installed in accordance with the latest edition of the National Electric Code NFPA No. 70 and any local codes.

Check rating plates on unit for rated volts, minimum circuit ampacity and maximum over current protection. Supply circuit power wiring must be 75°C. (167°F) minimum copper conductors only. Copper supply wires shall be sized to the National Electric Code or local code requirements, whichever is more stringent.

The unit is shipped wired for 230/240 Volt AC, 60 Hz, 1 Phase Operation. If the unit is to be operated at 208 VAC, 60 Hz, then follow the instruction on the indoor unit wiring diagram to change the low voltage transformer to 208 VAC operation.

Be sure the unit is properly grounded.

Class 2 low voltage control wiring should not be run in conduit with power wiring and must be separated from power wiring, unless class 1 wire of proper voltage rating is used. Low voltage control wiring should be 18 Awg, color coded (105°C minimum). For lengths longer than 100 ft., 16 Awg wire should be used. Make certain that separation of control wiring and power wiring has been maintained.

## Air Filter

An air filter must be installed prior to the air entering the evaporator coil to protect the coil, blower and other internal parts from excessive dirt and dust. If the unit is installed for the return air through the unit base, then the internal filter rack may be utilized.

If you decide to use a remote filter, then it should be sized for a maximum of 300 feet/minute air velocity.

If the unit is recess mounted in a wall utilizing the optional wall mount return filter grille be sure to install a filter in the panel. The door must be fastened in place securely to ensure proper filtration of return air.

*Easy slide in filter to replace bottom insulation board  
Solid panel easily installed with thumb screws*

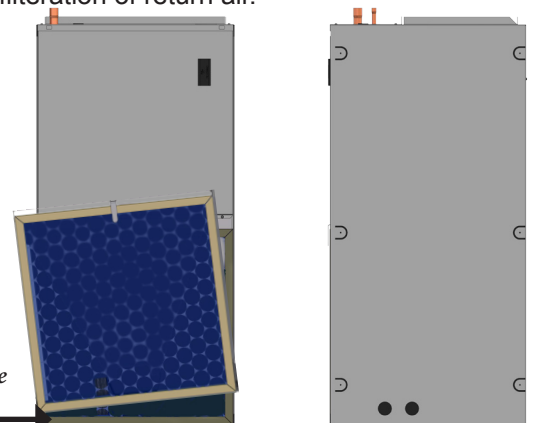

# INSTALLATION GUIDE

## Thermostat

Select a thermostat that is commonly referred to as a single stage cooling with electric heat subbase. This stat will energize the fan on a demand for heat or cool. Install the thermostat on an inside wall away from drafts, lights or other heat sources, in a location that has good air circulation from the other rooms being controlled by the thermostat. The thermostat should be mounted 4 to 5 feet above the floor.

## Sequence of Operation

**Cooling (cooling only or heat pump with reversing valve energized in heat mode):** When the thermostat calls for cooling, the blower relay is energized. The N.O. contacts will close after a time delay then the indoor blower will operate. The circuit between R and Y is completed which causes the contactor on the outdoor equipment to close, and start the compressor and the outdoor fan motor.

**Cooling (heat pump with reversing valve energized in cooling mode):** When the thermostat calls for cooling, the circuit between R and G and R and O is complete. Circuit R and O energizes the reversing valve to the cooling position. Circuit R and G energizes the blower relay. The N.O. contacts will close after a time delay then the indoor blower will operate. The circuit between R and Y is complete. Which causes the contactor on the outdoor equipment to close, and start the compressor and the outdoor fan motor.

**Heating (electric heat only):** When the thermostat calls for heat, the circuit between R and W is completed. The heat sequencer is energized. A time delay will occur, which allows the heating element(s) and the indoor blower motor to come on.

**Heating (heat pump reversing valve energized in the heat mode):** When the thermostat calls for heat, the circuits between R and B, R and Y and R and G are completed. Circuit R and B energize the reversing valve switching it to the heat position. Circuit R and Y energized the outdoor unit contactor starting the compressor and outdoor fan. Circuit R and G energizes the blower relay starting the blower motor.

If the indoor room temperature should continue to fall, circuit R and W2 is by the second-stage heat bulb on the thermostat. Circuit R-W2 energizes the heat sequencer. The completed circuit will energize the supplemental electric heat.

**Blower Time Delay:** This unit is equipped with timed on and a timed off relay. This relay delays the start and delays the stopping of the indoor fan motor to maximize the efficiency of the unit.

**Defrost:** When the unit starts the defrost cycle supplemental heat can be provided by connecting B on the blower coil to the defrost relay on the outdoor heat pump. This will complete the circuit between R and B (in the blower coil) through a set of contacts in the defrost relay in the outdoor unit. This circuit when it is connected, will help prevent cold air from being discharged from the indoor unit during the defrost.

## Maintenance

The system air filter(s) should be inspected, cleaned or replaced at least monthly. If the filter is mounted internal to unit, make sure that electrical power is disconnected before removing the access panels. Make certain that the access panels are replaced and secured properly before placing the unit back in operation. This product is designed for dependable service, however periodic maintenance should be scheduled to be conducted by trained professional service personnel. This service should be conducted at least annually, and should include testing and inspection of electrical and refrigerant components. The heat transfer surface should be cleaned. The blower motor is permanently lubricated for normal operating conditions.

# INSTALLATION GUIDE

## Warnings

Do not store or use any corrosives or combustibles in the vicinity of this unit. All panels must be in place and properly secured before operating this equipment.

All electrical power servicing this unit must be disconnected prior to removal of any panels. Service of this unit must be accomplished by qualified trained professional personnel only.

Conforms to UL STD 1995

THIS UNIT IS MANUFACTURED IN THE USA BY:



# WIRING DIAGRAM

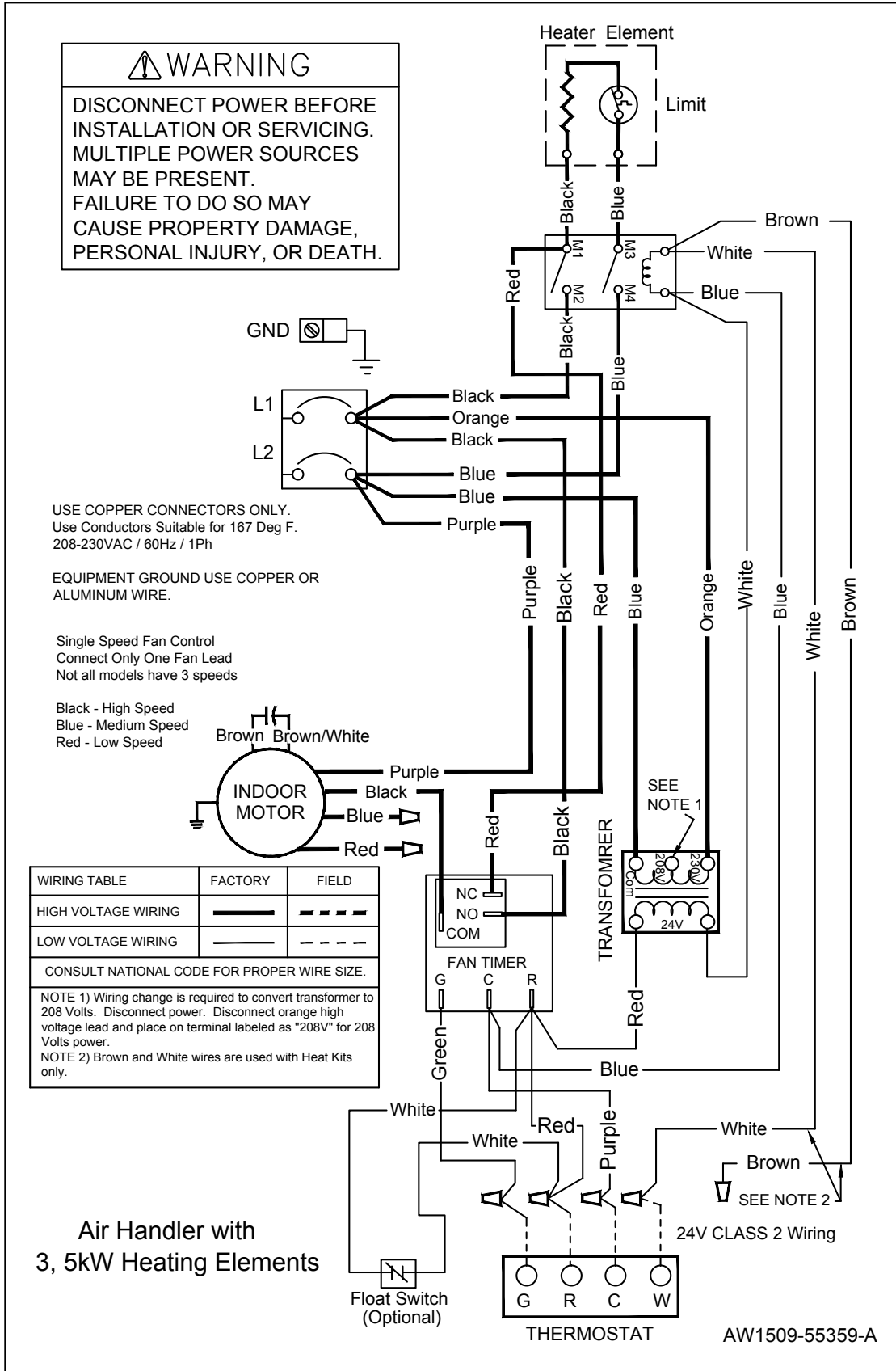

# WIRING DIAGRAM

**⚠ WARNING**  
 DISCONNECT POWER BEFORE  
 INSTALLATION OR SERVICING.  
 MULTIPLE POWER SOURCES  
 MAY BE PRESENT.  
 FAILURE TO DO SO MAY  
 CAUSE PROPERTY DAMAGE,  
 PERSONAL INJURY, OR DEATH.

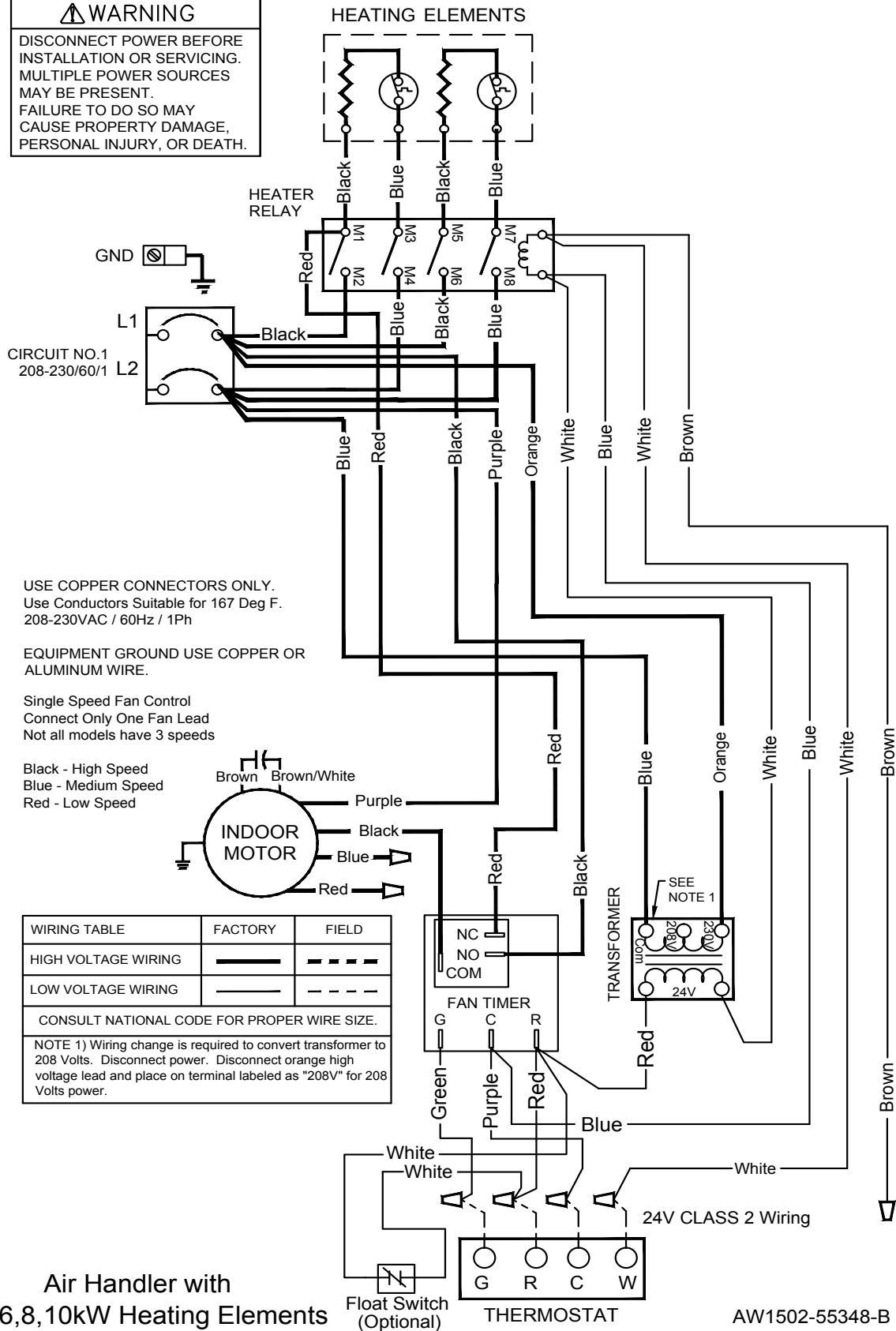

**Air Handler with  
6,8,10kW Heating Elements**

AW1502-55348-B

# WIRING DIAGRAM

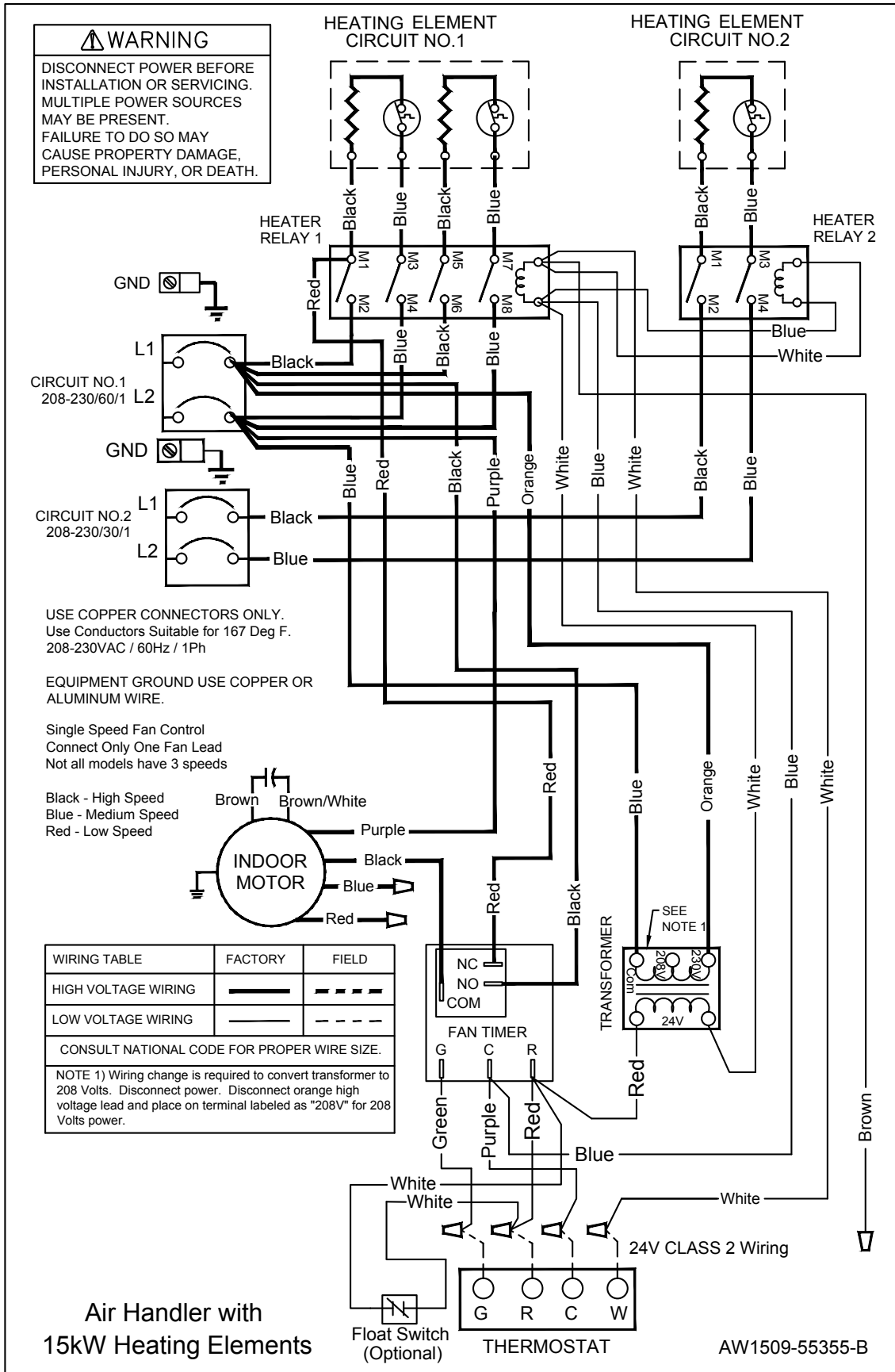



# WIRING DIAGRAM

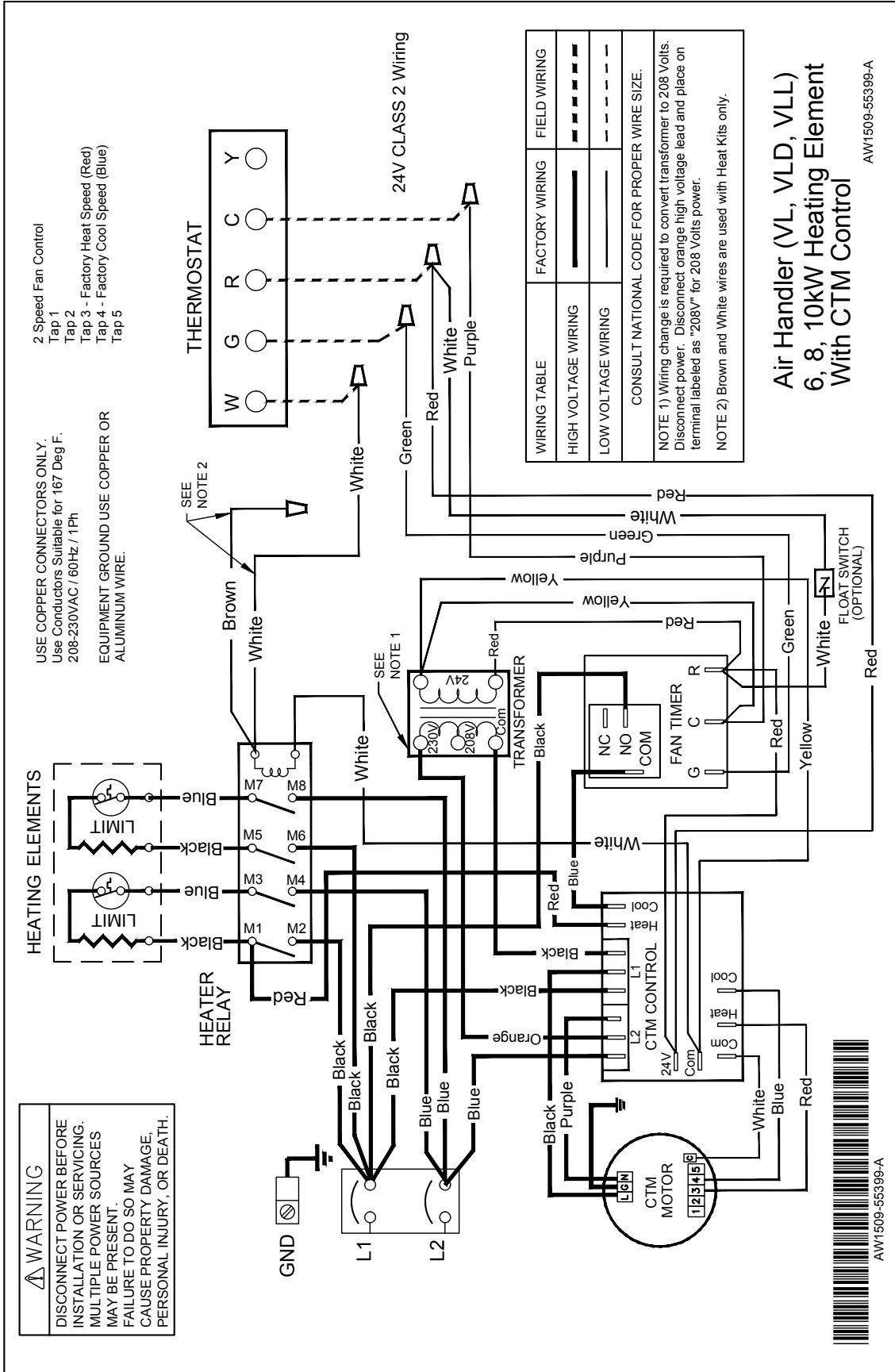

# VL\* APPLICATIONS

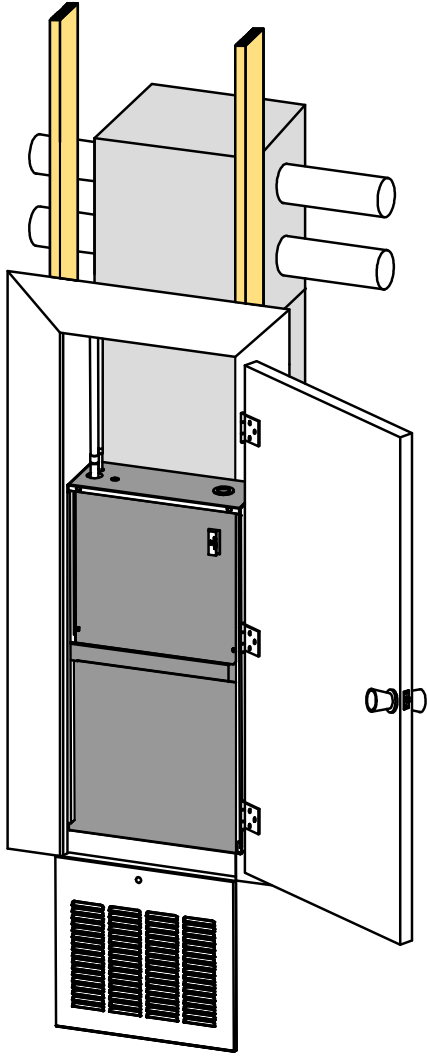

VL\* Air Handler Installed in Closet

To install the VL\* unit into the closet, remove bottom duct board and install a solid bottom door panel. Then install a filter grille below.

VL\* Bottom Door Panel  
Part #

- VL\* - LCP - 1AS
- VLD\* - LCP - 2AS

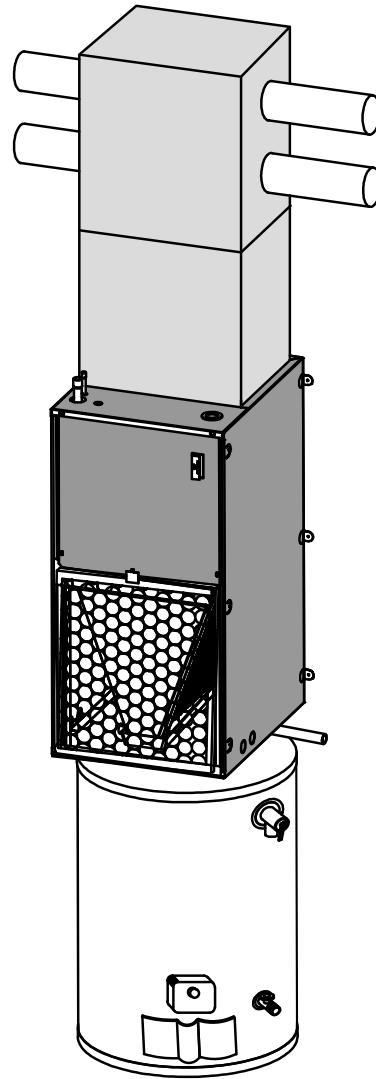

VL\* Air Handler Installed Above a  
Water Heater

To install the VL\* unit above a hot water heater, take solid panel off and install filter in front of the unit.

# VL\* APPLICATIONS

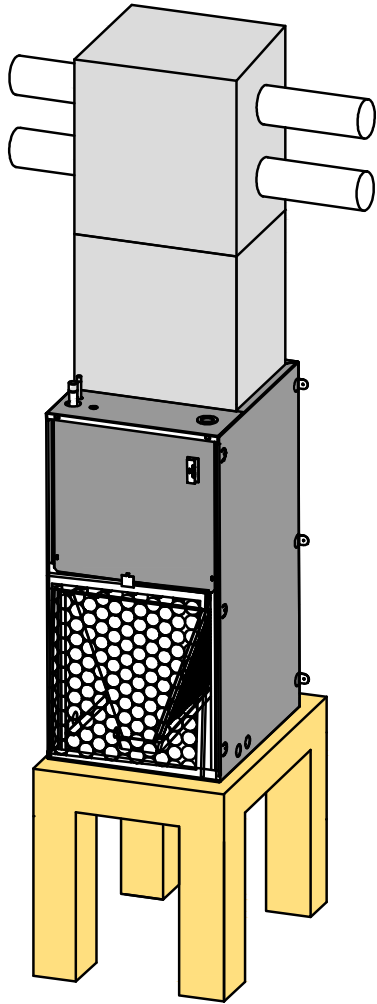

VL\* Air Handler Attached to Back Wall  
OR  
Mounted on a Platform in Utility Room

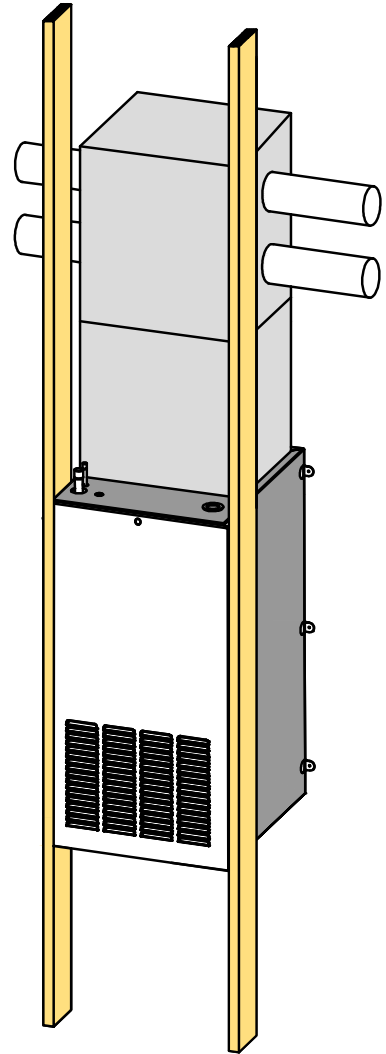

VL\* Air Handler Installed in a  
Stud / Wall Mount  
Application

Filter Panel Available in  
Various Sizes



Conforms to UL STD 1995



7037 Brittmoore Road  
Houston, Tx 77041

AllStyle Coil Company L.P.  
Made in USA

Since the manufacturer has a policy of continuous product and product data improvement, it reserves the right to change design and specification without notice.