

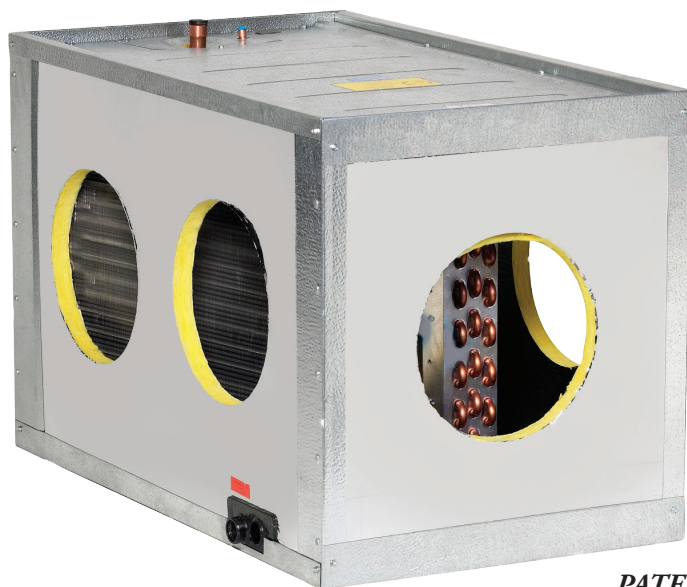

“AAA” SILVER - LINER HORIZONTAL PLENUM COILS



PATENT PRODUCT
5, 062, 280

PRODUCT FEATURES

- **Rated For R-22 & R-410a**
- **Cleanable, Mold-Resistant Silver-Liner Interior Surface**
- **UV Resistant Materials**
- **Fiberglass Removed from the Air Stream**
- **Superior Air Flow from Sides or End of Plenum**
- **Easily Removable Top Panel with Locking Air Seal and K.O. for UV Light**
- **Easy Installed Safety Drain Pan**
- **Pitched Drain Pan Elevates Coil from the Condensate**
- **Top Left and Right Refrigerant Drain Connections**
- **Factory Installed Thermal Expansion Valve**
- **Aluminum or Rifled, Copper Tube Option Available**
- **Enhanced Aluminum Fins**
- **Heavy Aluminum End Plates Vs. Galvanized Steel**
- **Pressure Tested to 500 PSI**
- **Fits Furnace 17” to 23” Wide for Easy Attic Installation**
- **Plenum Coil Combines an Adjustable Inlet Adapter, Cooling Coil, and Supply Plenum Into One Easy Install**

Safety Drain Pan has International Mechanical Code Council Approval





ASLT, ASLB, ASFM, ASKM ALL - IN - ONE PLENUM COILS

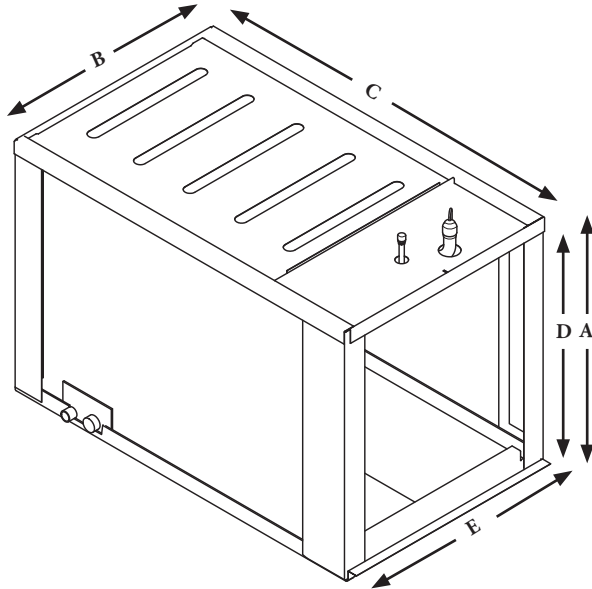

3/4" FPT Primary Drain Connection
3/4" Slip Secondary Drain Connection
3/8" Refrigerant Liquid Line
Refrigerant Suction Line
 1.5 to 3.0 Tons - 3/4"
 3.5 to 5.0 Tons - 7/8"
Optional Galvanized Steel Cabinet

Cabinet Specifications					
Model	Height A	Width B	Length C	Opening D	Opening E
ASLT	18.25"	20.25"	26.25"	13.00" to 18.00"	16.00" to 20.25"
ASLB	18.25"	20.25"	34.375"	13.00" to 18.00"	16.00" to 20.25"
ASLL	18.25"	20.25"	40.375"	13.00" to 18.00"	16.00" to 20.25"
ASFM	22.25"	20.25"	34.375"	17.00" to 21.00"	16.00" to 20.25"
ASFL	22.25"	20.25"	40.375"	17.00" to 21.00"	16.00" to 20.25"
ASKM	26.25"	20.25"	34.375"	21.00" to 23.00"	16.00" to 20.25"
ASKL	26.25"	20.25"	40.375"	21.00" to 23.00"	16.00" to 20.25"

Specifications may change without notice

ASLT, ASLB, ASFM, ASKM SECONDARY SAFETY DRAIN PANS

STANDARD FEATURES

- Exact Fit for AllStyle Plenum Coils
- Sturdy Safety Auxiliary Drain Pan
- Seamless One Piece 3/4" FPT Drain Connection
- Mounting Brackets are Integral to the Drain Pan
- ETL Listed Accessory for AllStyle Coils

ORDERING INSTRUCTIONS

Specify Complete Model Number or Part Number
(i.e. RP 46003)

or

Add "S" to the End of the Plenum Coil Model Number



Safety Drain Pan Specifications

Part Number	Dimensions	Fits Plenum Coil Model	Drain Connection
RP 46002	37.50" x 22.375" x 1.50"	ASLB, ASFM, ASKM	3/4" FPT
RP 46003	27.50" x 22.25" x 1.50"	ASLT, ASFT, ASKT	3/4" FPT
RP 46006	43.00" x 22.25" x 1.50"	ASLL, ASFL, ASKL	3/4" FPT
Specifications may change without notice			



“AAA” SILVER - LINER HORIZONTAL PLENUM COILS

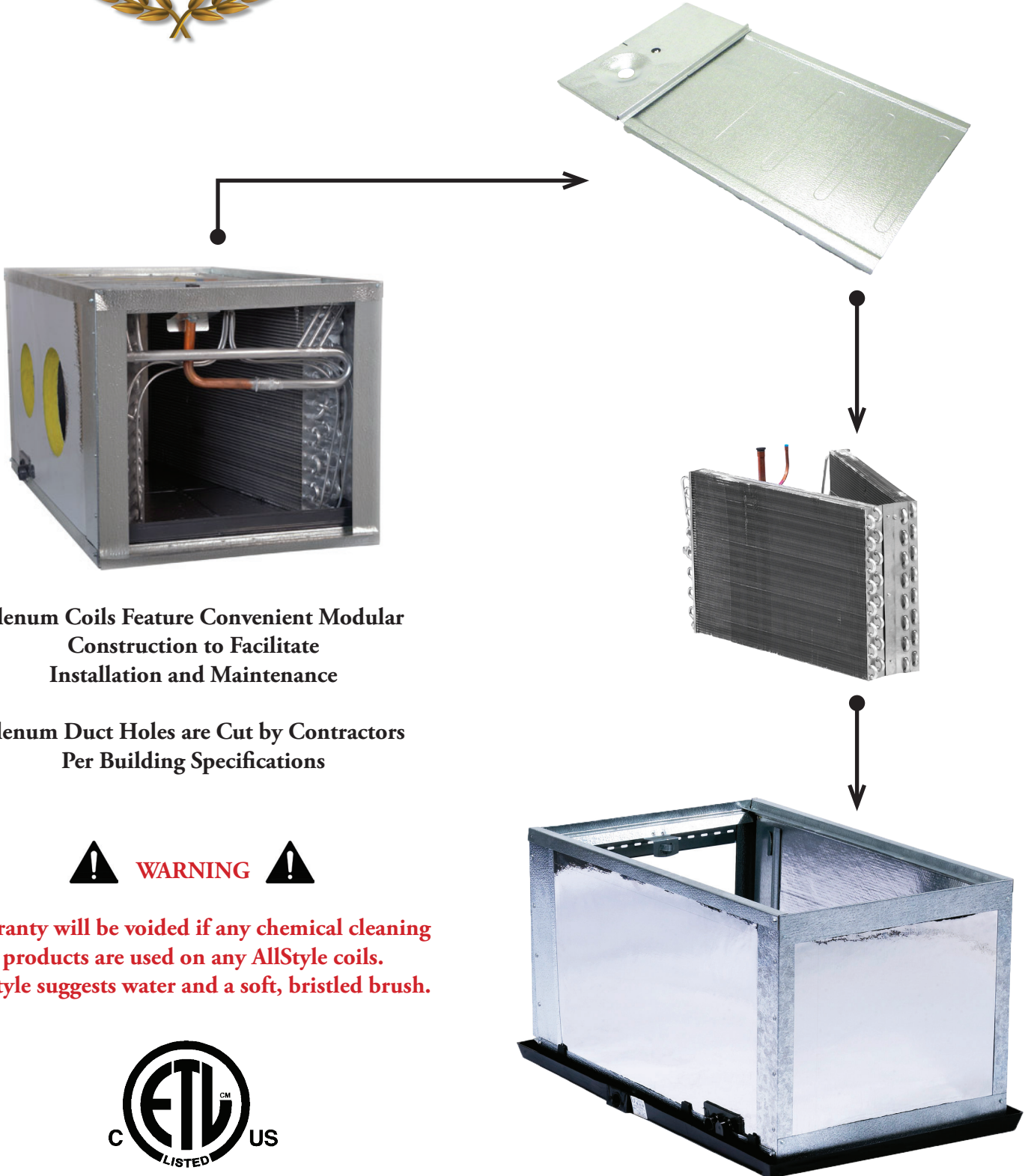

Plenum Coils Feature Convenient Modular Construction to Facilitate Installation and Maintenance

Plenum Duct Holes are Cut by Contractors Per Building Specifications



WARNING



Warranty will be voided if any chemical cleaning products are used on any AllStyle coils. AllStyle suggests water and a soft, bristled brush.



Intertek