

THE FIRST PREDICTIVE SUMP PUMP SENSOR

Sumpie is more than a sump pump alarm. It's the world's first predictive sump pump sensor. Sumpie monitors sump pit water levels in real-time and tracks sump pump performance for predictive maintenance and flood protection at commercial and residential properties. The system sends alerts and notifications to assigned users, in advance, if the pit is filling above an acceptable level or the pump isn't operating efficiently.

Sumpie can help you make money and keep customers happy.

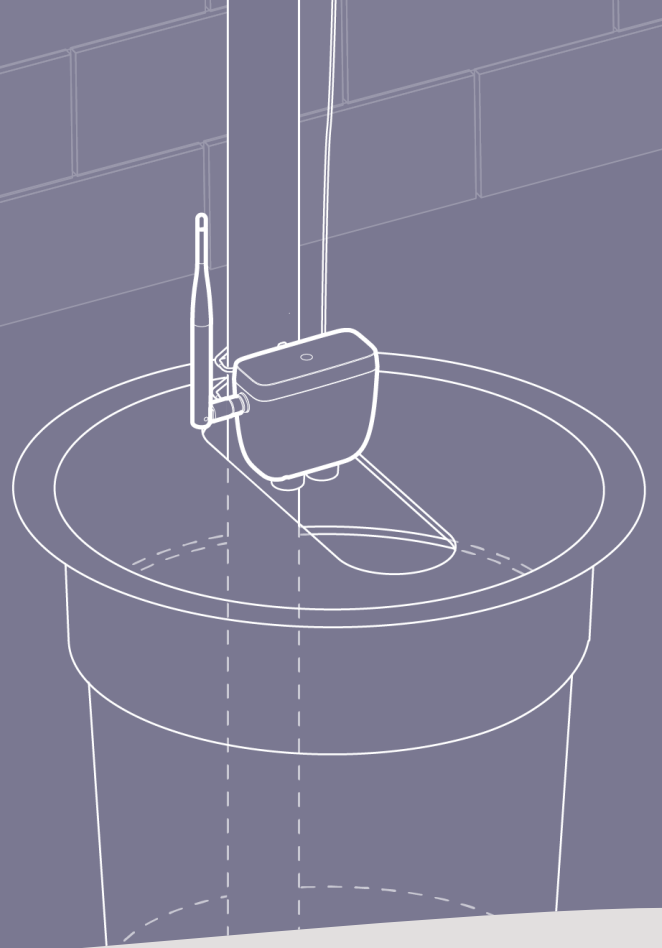

INCREASE REVENUE

- Sell premium monitoring and service contracts with new business
- Convert customers during service calls
- Upsell on existing service contracts



STAND OUT FROM THE COMPETITION

- Deliver new smart flood detection technology
- Provide unique 24/7 monitoring service plans



BOOST CUSTOMER RETENTION

- Increase customer satisfaction
- Grow business through referrals

For more information, latest product specifications and to order, contact your Account Manager or check your Distributor's eCommerce website.

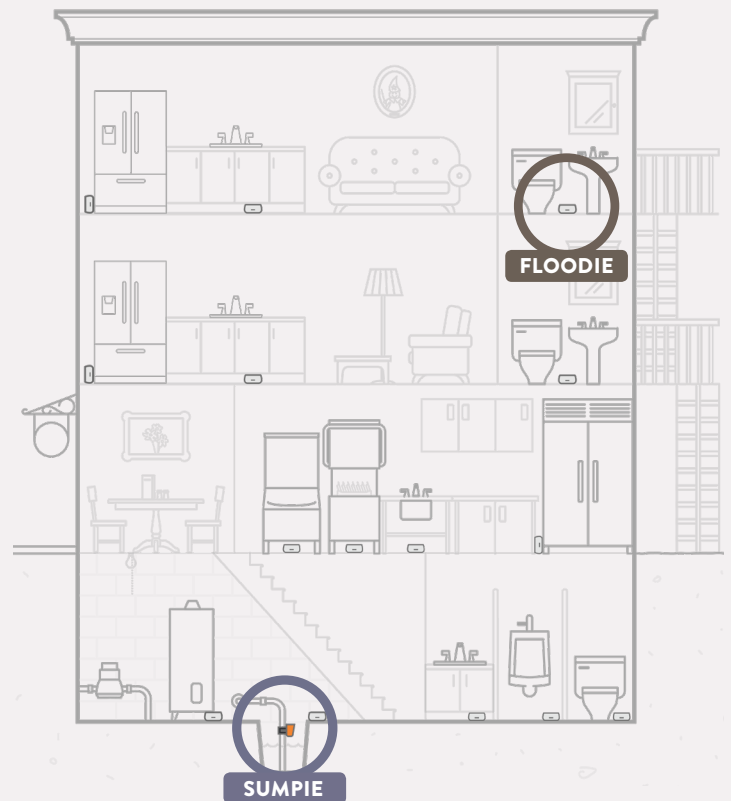

SUMPIE

Sump Pump Sensor

As a service provider, you know that sump pumps are installed to make sure that sump pits don't overflow, and that most property owners don't pay attention to their sump pump or know whether the sump pump is working properly. Sumpie can now predict problems and prevent property damage for your customers. Additionally, property owners might not know that:

11%
of all insurance claims are from failed sump pumps during heavy rainstorms

25%
of properties with a backup pump don't have a backup battery

80%
of properties with sump pits have no backup pump

\$43,000
is the average cost of a flooded basement



WATER LEVEL



SUMP PUMP HEALTH



MECHANICAL FAILURE



POWER OUTAGES



OVERFLOW WARNING

QUICK INSTALLATION

Sumpie is a professional-grade sensor that can be installed in **2 minutes** in normal and sealed sump pits.

DASHBOARD & APP

The monitoring service includes access to the Dashboard and App for contractors and property owners. The platform provides instant alerts and 24-hour monitoring for all assigned users for each property.

OPERATIONS CONSOLE

The operations console is your control center for all of your customers' sensors. The platform provides:

- Access to all properties, sensors, analytics and alerts in one place
- Flexibility to sort properties by location, assigned technician or sensor
- Event warnings and alerts to help you identify, proactively diagnose and dispatch the right service.

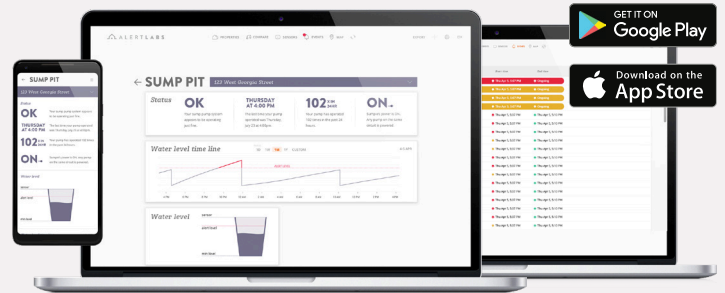

EMERGENCY NOTIFICATIONS AND ALERTS

Sumpie uses a cellular connection to deliver you and your customers instant text messages, emails, in-app, and phone call alerts when there is a problem in the sump pit or with the pump. The backup battery keeps Sumpie working without electricity to provide 24/7 alarms and alerts for up to 3 days.

FLOODIE FLOOD SENSOR

Easily pair Floodie flood sensors with Sumpie to provide additional leak and flood protection.

