



Installation Instructions

B Series

Multi-Position & Hydronic Air Handlers

Electric or Hot Water Heat, with available Variable-Speed High Efficiency ECM Motor

TABLE OF CONTENTS		PAGE	PAGE
Air Handler Safety.....	1	Connect Refrigerant Lines	7
General	2	Refrigerant Line Installation	8
Tools and Parts.....	2	Refrigerant Charging Instructions	8
Outdoor System Requirements.....	2	Supply Voltage Connections.....	9
Location Requirements	2	Thermostat Connections.....	10
Installation Clearances.....	3	Wiring Diagram	13
Configuration Options	3	Blower Performance Data.....	14
Drain Pan Connections	4	Air Handler Checks.....	16
Electrical Requirements	5	Hot Water Coil Installation	17
Ductwork Requirements.....	5	Hot Water Coil Flushing.....	18
Inspect Shipment	5	Sequence of Operation.....	19
Install Condensate Drain.....	6	Air Handler Maintenance	19
Install Ductwork.....	6	Assistance or Service	19
Metering Device.....	7	Warranty	20

AIR HANDLER SAFETY

SAFETY CONSIDERATIONS

Your safety and the safety of others are very important.

We have provided many important safety messages in this manual and on your appliance. Always read and obey all safety messages.



This is the safety alert symbol.

This symbol alerts you to potential hazards that can kill or hurt you and others.

All safety messages will follow the safety alert symbol and signal word. These signal words mean the following:

DANGER: You can be **killed or seriously injured** if you don't immediately follow instructions.

WARNING: Indicate a potentially hazardous situation which, if not avoided, could result in **death or serious injury**.

CAUTION: Indicates a potentially hazardous situation which, if not avoided, may result in **minor or moderate injury**. Caution may also be used to alert against unsafe practices.

NOTICE: Indicates a statement of company policy as the message relates directly or indirectly to the safety of personnel or protection of property.

IMPORTANT: More detailed information concerning the statement of company policy as the message relates directly or indirectly to the safety of personnel or protection of property.



All safety messages will tell you what the potential hazard is, tell you how to reduce the chance of injury, and tell you what can happen if the instructions are not followed.



Product improvement is a continuous process at Advanced Distributor Products. Therefore, product specifications are subject to change without notice and without obligation on our part. Please contact your ADP representative or distributor to verify details.

© by Advanced Distributor Products. All rights reserved.

GENERAL

 **WARNING** 

This product may contain fiberglass wool insulation. Glass wool fibers are known to the State of California to cause cancer. Disturbing insulation during installation, maintenance, or repair may expose you to glass wool fibers and may cause respiratory, skin or eye irritation. For further information on risks associated with fiberglass wool, consult Material Safety Data Sheet available from OEM.

These instructions are intended as a general guide only and do not supersede any national or local codes in any way. Compliance with all local, state, or national codes pertaining to this type of equipment should be determined prior to installation.

Read this entire instruction manual, as well as the instructions supplied in separate equipment, before starting the installation. All models are designed for indoor installation only.

The installation of the air handler, field wiring, warm air ducts, etc. must conform to the requirements of the National Electrical Code, ANSI/NFPA No. 70 (latest edition) in the United States, and any state laws, and local ordinances (including plumbing or wastewater codes). Local authorities having jurisdiction

TOOLS AND PARTS NEEDED

Assemble the required tools and parts before starting installation. Read and follow the instructions provided with any tools listed here:

<i>1/4" Nut Driver</i>	<i>Tape Measure</i>
<i>Level</i>	<i>Hammer</i>
<i>Screw Drive</i>	<i>Sealant</i>
<i>Adjustable Wrench</i>	<i>UL listed wire nuts</i>

Replacement orifice (if needed; see "Verify Orifice Size.")



OUTDOOR SYSTEM REQUIREMENTS

The air handler is designed to match, and must be used with, outdoor units as rated in AHRI. The indoor sections are manufactured with an interchangeable refrigerant metering device to provide optimum refrigerant control and system

LOCATION REQUIREMENTS

NOTE: When the unit is installed in a very humid space and used in cooling applications, excessive sweating may occur on outside of unit. To prevent excessive sweating wrap unit with 1" fiberglass insulation. All openings should be sealed to prevent air leakage that could cause condensate to form inside the cabinet.

- If installed in an unconditioned space, sealant should be applied around the electrical wires, refrigerant tubing, and condensate lines where they enter the cabinet.

 **WARNING** 

Electrical Shock

Disconnect power before servicing.

Replace all parts and panels before operating.

Electrically ground air handler.

Connect ground wire to ground terminal marked "GRD".

Failure to do so can result in death or electrical shock.

Explosion Hazard

Keep flammable materials and vapors, such as gasoline, away from this unit.

Place this unit so that the heating elements are at least 18in (46cm) above the floor for a garage insulation.

Failure to follow these instructions can result in death,

should be consulted before installation is made. Such applicable regulations or requirements take precedence over the general instructions in this manual.

Install the conditioned air plenum, ducts and air filters (not provided) in accordance with NFPA 90B Standard for the Installation of Warm Air Heating and Air-Conditioning Systems (latest edition).

Check local codes, check existing electrical supply, and read "Ductwork Requirements," and "Electrical Requirements," before purchasing parts.

The correct orifice size may be contained in the replacement orifice package located inside the control box of the outdoor unit. If this package does not contain the correct orifice for your air handler, you must purchase the correct orifice size.

performance with a variety of different capacities of outdoor units. In some cases, the AHRI rating may require that the air handler refrigerant metering device be changed to obtain rated performance.

- Electrical wires should be sealed on the inside where they exit the conduit opening. Sealant is required to prevent air leakage into and condensate from forming inside the air handler, control box, and on electrical controls.
- The air handler must be installed in such a way as to allow free access to the coil/filter compartment and blower/control compartment.

INSTALLATION CLEARANCES

Clearance to combustible material to be 0 inches to unit casing, and 0 inches to plenum and duct for first 36 inches.

The air handler can be installed in a closet with a false bottom to form a return air plenum or be installed with a return air plenum under the air handler.

Louvers or return air grilles are field supplied. Local codes may limit application of systems without a ducted return to single-story buildings.

- Install louvers in a closet. Use the “Minimum Filter Requirements Chart” to determine the opening size that will provide the amount of free air you will require. If using louvers or grilles, match the free area rating of the louver or grille to the Minimum Return Air Free Area you deter-

mined to be necessary by consulting the “Minimum Filter Requirements Chart.”

- If the free area is not known, assume a 25% free area for wood or a 75% free area for metal louvers or grilles.
- If the return air plenum is used, the return air grille should be immediately in front of the opening in the plenum to allow for the free flow of return air.
- When not installed in front of the opening, there must be adequate clearance around the air handler to allow for the free flow of return air.

CONFIGURATION OPTIONS

For ease of installation, it is best to make any necessary coil configuration changes before setting air handler in place.

- Vertical upflow Air Handlers only contain 1 drain pan.
- Multi-position Air Handlers contain 2 drain pans.

Vertical Installations (Upflow)

The air handler must be supported on the bottom only and set on solid floor or field supplied supporting frame. Securely attach the air handler to the floor or supporting frame. For best efficiency and airflow, horizontal drain pan (if installed) should be removed from units in upflow configurations.

Horizontal Installations

Horizontal installations can be left-hand or right-hand air supply.

Adequate support must be provided to ensure cabinet integrity. Units mounted horizontal should be mounted with a slight angle toward the drain connections to be used so that the drain pan will empty completely without water standing in the pan. Ensure that there is adequate room to remove service and access panels if installing in the horizontal position.

IMPORTANT:

- This coil is provided with a secondary drain that should be trapped and piped to a location that will give the occupant a visual warning that the primary drain is clogged. See “Install Condensate Drain.”
- When an evaporator coil is installed in an attic or above a finished ceiling, an auxiliary drain pan should be provided under the air handler as specified by most local building codes.
- Extend suction line insulation into the coil cabinet by 2” to prevent moisture from dripping onto the insulation (the rubber grommet may need to be removed).

Conversion from Vertical to Horizontal

A vertical only air handler may be converted to horizontal air discharge by installing a horizontal drain pan kit (see accessories).

A multi-position air handler may be converted from horizontal left-hand discharge to horizontal right-hand discharge without additional parts.

Suspended Cabinet Installation

NOTE: Air handler must be positioned with one side parallel to the floor when in the horizontal position, with a 1/2” pitch towards drain.

The suspending means must be field fabricated, and should consist of a minimum of two “cradles” made by attaching two 3/8” all thread rods to a length 1-5/8” x 7/8” unistrut. Cradles should not interfere with panel removal, drain connections, or refrigerant connections.

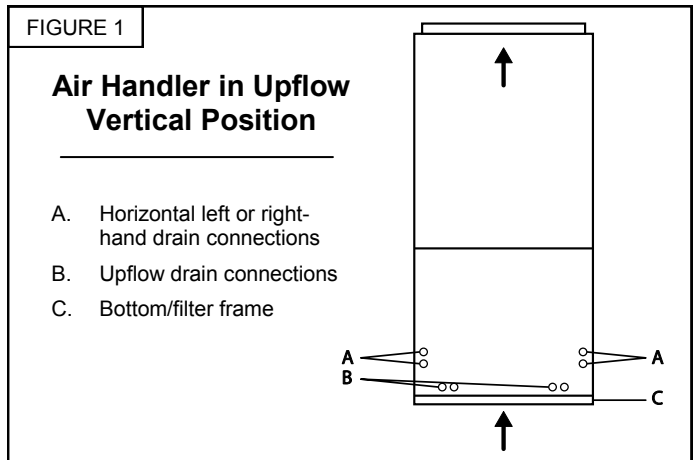

DRAIN PAN CONNECTIONS

Horizontal installations can be either “Right” or “Left.”

For horizontal right installations, a drain pan location change may be required. Use drain connections “A” below. For horizontal left installations, use drain connections marked “B” below.

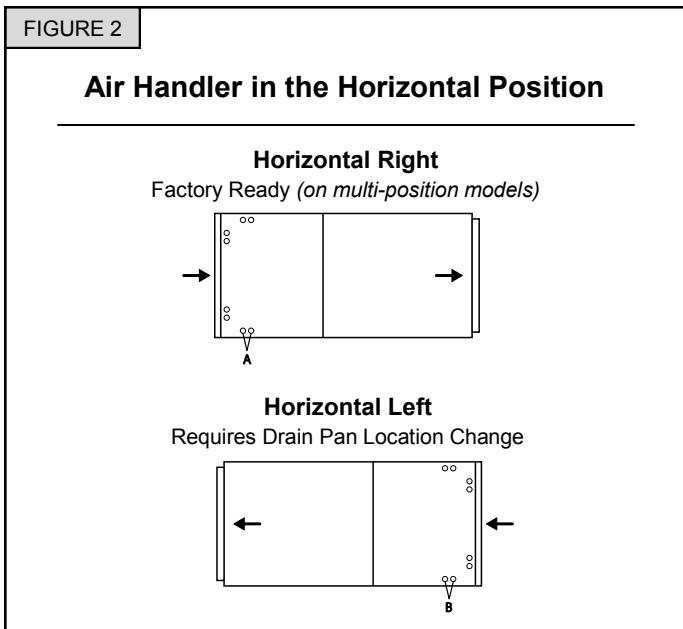

Models listed in Figure 3 are shipped in the horizontal right airflow configuration. To convert to horizontal left airflow, follow these steps:

1. Remove and set aside all front panels.
2. Locate slant coil support bracket and remove the 2 screws from the side of the cabinet.
3. Remove the horizontal drain pan retaining bracket.
4. Carefully remove coil assembly and drain pan(s) as one assembly from the unit.

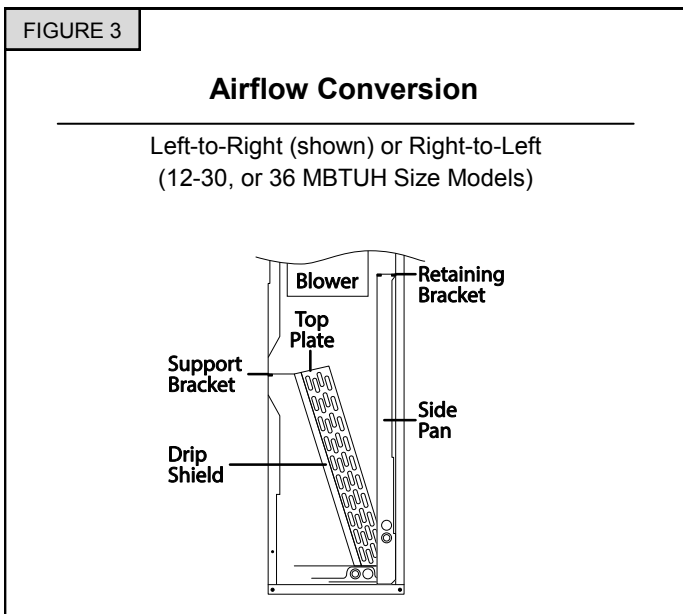

5. If the air handler is to be used for upflow, the horizontal pan and bracket can be discarded.
6. Remove the screws holding the coil bracket to the left side of top plate. Reposition coil support bracket to right side of top plate.
7. Remove drip shield from front left-hand side of coil assembly and attach to front right-hand side.
8. Repeat for the rear drip shields. Failure to move drip shields will allow air by-pass around coil.
9. If needed for horizontal installation, slide the horizontal drain pan over the bottom pan. If vertical application, only install bottom pan. Install the pan(s) into bottom left hand side of the air handler. If installed properly the drains should match knockouts on the connection panel (Refer to drawing).
10. Install coil assembly back into unit.
11. Re-install slant coil support bracket retaining screws.
12. Knockout required panels for drain line connections.

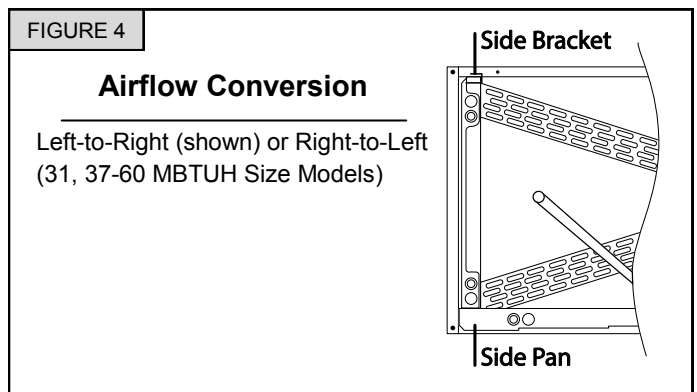

Models listed in figure 4 are shipped in the horizontal right airflow configuration. To convert to horizontal left airflow, follow these steps:

1. Remove and set aside front panels.
 2. Remove side bracket with 2 screws.
 3. Carefully remove coil assembly and bottom drain pan as one assembly from the unit.
 4. Move side drain pan from left hand side of coil to right.
 5. Move coil support bracket under top plate from left hand side of coil to right.
 6. Install modified coil assembly back into unit.
 7. Reinstall side bracket with 2 screws on opposite side.
 8. Knockout required panels for drain line connections.
- CAUTION:** Take care when removing coil assembly from unit. Installation in this configuration may cause the coil to tip into unit once clear of the cabinet. Support the coil when removing.

ELECTRICAL REQUIREMENTS

WARNING

Electrical Shock

Disconnect power before servicing.

Replace all parts and panels before operating.

Electrically ground air handler.

Connect ground wire to ground terminal marked "GRD".

Failure to do so can result in death or electrical shock.

Explosion Hazard

Keep flammable materials and vapors, such as gasoline, away from this unit.

Place this unit so that the heating elements are at least 18in (46cm) above the floor for a garage insulation.

NOTE: Use copper conductors only.

- All field wiring must be done in accordance with National Electrical Code, applicable requirements of UL and local codes, where applicable.
- Electrical wiring, disconnect means and over-current protection are to be supplied by the installer. Refer to the air handler rating plate for maximum over-current protection, minimum circuit Ampacity, as well as operating voltage.
- The power supply must be sized and protected according to the specifications supplied on the product.

DUCTWORK REQUIREMENTS

- Install the conditioned air plenum, ducts and air filters (not provided) in accordance with NFPA 90B Standard for the Installation of Warm Air Heating and Air-Conditioning Systems (latest edition).
- The air handler is provided with flanges for the connection of the plenum and ducts.
- Replacement air filters must be listed as Class 2 furnace air filters.
- Supply and return ductwork must be adequately sized to meet the system's air requirements and static pressure capabilities. Ductwork should be insulated with a minimum of 1" thick insulation with a vapor barrier in conditioned areas and 2" minimum in unconditioned areas.
- Supply plenum should be the same size as the flanged opening provided around the blower outlet and should extend ideally at least 3 ft. from the air handler before turning or branching off plenum into duct runs. The plenum forms an extension of the blower housing and minimizes air expansion losses from the blower.

INSPECT SHIPMENT

WARNING

Excessive Weight Hazard

Use two or more people to move and install air handler.

Failure to do so can result in back or other injury.

If damage is found, it should be noted on the carrier's freight bill. Damage claims should be filed with the carrier immediately. Claims of shortages should be filed with the seller within 5 days.

NOTE: If any damages are discovered and reported to the carrier, do not install the unit because your claim may be denied.

All air handlers are performance tested. Each unit consists of a blower assembly, refrigerant coil and controls, in an insulated, factory-finished enclosure. Knockouts are provided for electrical wiring entrance.

1. Check the unit rating plate to confirm specifications are as ordered.
2. Upon receipt of equipment, carefully inspect it for possible shipping damage. Take special care to examine the unit if the carton is damaged.

Filter Size Chart	
Unit Size (MBTUH)	Filter Size
12-24	12" x 20"
25-30 & 36	16" x 20"
31 & 37-48	16" x 24"
60	18" x 24"

INSTALL CONDENSATE DRAIN

The air handler is provided with 3/4" NPT condensate drain connections. A field fabricated secondary drain pan, with a drain pipe to the outside of the building, is required in all installations over a finished living space or in any area that may be damaged by overflow from the main drain pan. In some localities, local codes may require a secondary drain pan for horizontal installations. For horizontal applications make sure unit is tilted with a 3/4" drop in the horizontal position towards the drain pan to ensure proper condensate drainage. The blower and coil should also be tilted 1/2" from back to front toward the drain line so that the drain pan will empty completely without water standing in pan.

1. Remove the appropriate drain knockouts. See "Drain Pan Connections Section". You may need to remove the indoor coil assembly from the cabinet.
2. Connect primary drain line connection to the primary drain pan connection. The primary drain connection is flush with the bottom of the inside of the pan. Secondary connection is raised above the bottom of the inside of the pan.
3. Secondary drain connections, if used, should be connected to a separate drainage system. Run the secondary drain so the occupant will be able to notice if water is flowing through the secondary drain.
4. Install a 2" trap in both the primary and secondary drain lines as close to the unit as practical. Make sure the top of the trap is below the connection to the drain pan to allow complete drainage of the pan. **NOTE:** Horizontal runs must also have an anti-siphon air vent (standpipe) installed ahead of the horizontal run. See Figure 5. An extremely long horizontal run may require an oversized drain line to eliminate air trapping. **NOTE:** Do not operate air handler without a drain trap. The condensate drain is on the negative pressure side of the blower; therefore, air being pulled through the condensate line will prevent positive drainage without a proper trap.

5. Route the drain line to the outside or to an appropriate drain. Drain lines must be installed so they do not block service access to the front of the air handler. A 24" clearance is required for filter, coil, or blower removal and service access. **NOTE:** Check local codes before connecting the drain line to an existing drainage system.
6. Insulate the drain lines where sweating could cause water damage

Upon completion of installation, it is the responsibility of the installer to ensure the drain pan(s) is capturing all condensate, and all condensate is draining properly and not dripping into duct/system.

1. Pour several quarts of water into drain pan, enough to fill drain trap and line.
2. Check to make sure the drain pan is draining completely, no leaks are found in drain line fittings, and water is draining from the end of the primary drain pan.
3. Correct any leaks found.

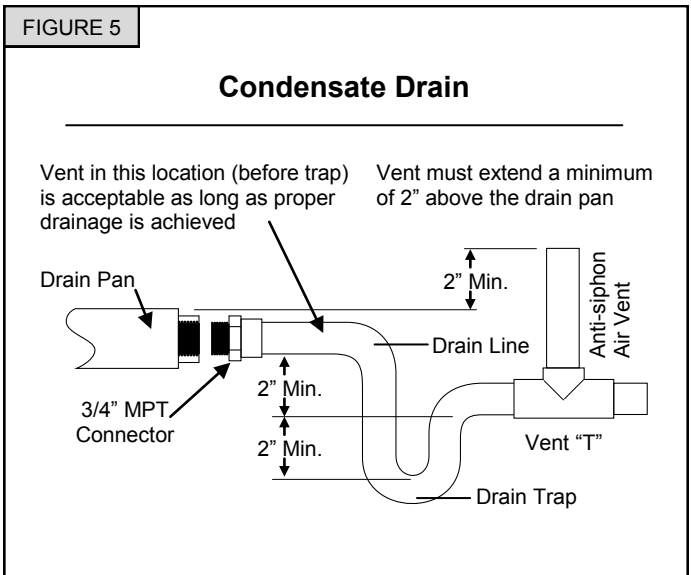

INSTALL DUCTWORK

IMPORTANT:

- Install ductwork in accordance with NFPA 90B and any local codes.
- Connect supply air duct to the flange on top of the air handler. If an isolation connector is used, it must be nonflammable.
- A return air duct system is recommended. If the unit is installed in a confined space or closet, a return connection must be run to a location outside the cabinet.

METERING DEVICE

Thermal Expansion Valve (TXV)

Some models are equipped with a factory installed thermal expansion valve. The sensing bulb of the valve needs to be removed during installation and reattached to the header (Fig 6). For optimum performance, attach and insulate the bulb at a 10 to 2 o'clock position outside of the cabinet to the main suction line no more than one foot from suction line connection.

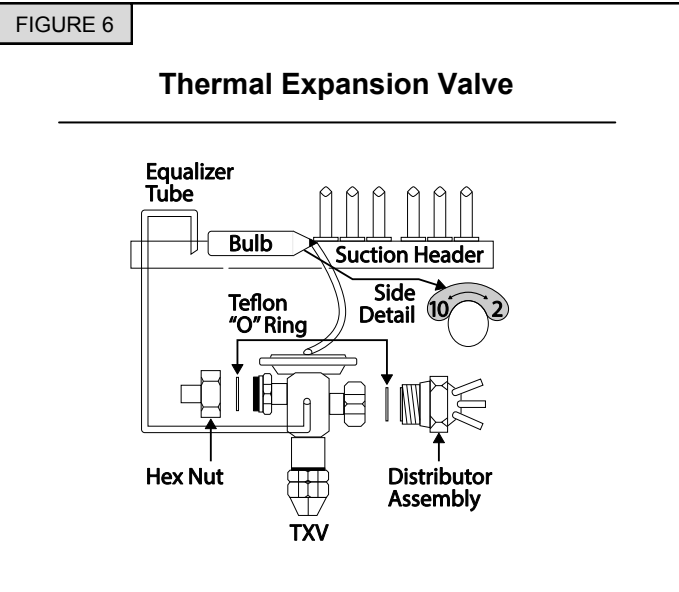

Pistons

As shipped from the factory, the piston installed in each coil is chosen for the nominal BTUH capacity of the coil. A label on the liquid line identifies the piston size. For optimum performance the piston should be sized to match the nominal BTUH of the condensing unit.

When changing pistons use the following procedure:

1. Loosen hex nut located on liquid line and separate from distributor assembly.
2. Remove the existing piston from inside the distributor assembly
3. Insert the desired piston into the distributor assembly.
4. Inspect "O" ring and replace if damaged. Ensure gasket is in place.
5. Re-install hex nut to body and torque to 10 ft-lbs.

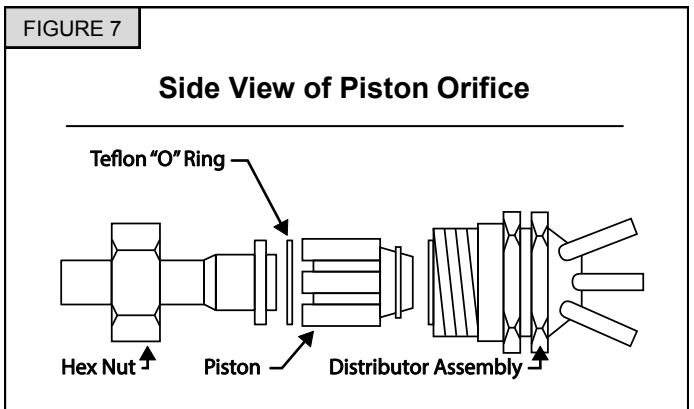

REFRIGERANT LINE INSTALLATION

Refrigerant lines must be connected by a licensed, EPA certified refrigerant technician in accordance with established procedures.

IMPORTANT:

- Connecting refrigerant lines must be clean, dehydrated, refrigerant-grade copper lines. Air handler coils should be installed only with specified line sizes for approved system combinations.
- Use care with the refrigerant lines during the installation process. Sharp bends or possible kinking in the lines will cause a restriction.
- Do not remove the caps from the lines or system connection points until connections are ready to be completed.

1. Route the suction and liquid lines from the fittings on the indoor coil to the fittings on the outdoor unit. Run the lines in a direct path, avoiding unnecessary turns and bends.
2. Ensure that the suction line is insulated over the entire exposed length and that both suction and liquid lines are not in direct contact with floors, walls, ductwork, floor joists, or other piping.

3. Connect the suction and liquid line to the evaporator coil.
4. To avoid damaging the rubber grommets in the cabinet while brazing, slide the rubber grommets over the refrigerant lines until they are away from the heat source.
5. Braze with an alloy of silver or copper and phosphorus with a melting point above 1,100°F. **NOTE:** Do not use soft solder.
6. Reinstall the rubber grommets after brazing is finished.
7. Make sure the outdoor air conditioning unit has been put in place according to the Installation Instructions and is connected to the refrigerant lines.

ADP recommends installing a filter drier and sight glass in the liquid line. While brazing, purge the system with Nitrogen to prevent contamination. ADP recommends reattaching and insulating the TXV sensing bulb at a 10 to 2 o'clock position on the suction line, outside the coil housing, no more than one foot from the connection. Evacuate the system to 500 microns to ensure proper air and moisture removal (**Note:** *Deep evacuation or triple evacuation method recommended*). Open the suction service valve slowly and allow the refrigerant to bleed into the system before opening the liquid service valve.

REFRIGERANT CHARGING INSTRUCTIONS

When charging in cooling mode, the outdoor temperature should be 60°F or higher. To allow the pressures to stabilize, operate the system a minimum of 15 minutes between adjustments. When adjusting charge to systems with micro-channel outdoor coils, make small (1 ounce or less) adjustments as these systems are very sensitive to refrigerant charge.

TXV Charging^{2,3,4} – Use the charging method recommended by the outdoor unit instructions. Alternatively, ADP recommends charging to 12°F sub-cooling for AC units and 10°F sub-cooling for heat pump units. In addition, if equipped with an adjustable valve, adjust to 10°F superheat.

Fixed Orifice Charging^{2,3,4} – Use the superheat recommended by the outdoor unit instructions. Alternatively, ADP recommends charging to the superheat table below.

Outdoor Air Temp. (°F)	60	65	70	75	80	85	90	95	100	105	110	115
Superheat (°F)	31	28	25	22	20	16	13	10	8	6	5	5

For heat pump units initially charged in the cooling mode, final adjustments to charge in the heating mode are acceptable if necessary. Some heat pump units require charging in the heating mode. In this case, refer to the outdoor instructions for recommended charging procedures.

If the system is undercharged after the initial charge, add refrigerant until the sight glass is clear and recommended pressures, temperatures, sub-cooling and superheat can be obtained. If the system is overcharged after the initial charge, recover refrigerant until recommended pressures, temperatures, sub-cooling and superheat can be obtained.

Notes:

1. If any problems or questions regarding charge occur, contact customer service.
2. OEM charging methods vary depending on design and application. Verify all recommended pressures, temperatures, sub-cooling and superheat settings result in the proper charge.
3. ADP coils may require charge compensation due to size variation versus the OEM coil.
4. Temperatures are ±2°F unless otherwise recommended.

SUPPLY VOLTAGE CONNECTIONS

! **WARNING** !

Electrical Shock

Disconnect power before servicing.

Replace all parts and panels before operating.

Electrically ground air handler.

Connect ground wire to ground terminal marked "GRD".

Failure to do so can result in death or electrical shock.

Explosion Hazard

Keep flammable materials and vapors, such as gasoline, away from this unit.

Place this unit so that the heating elements are at least 18in (46cm) above the floor for a garage insulation.

Unit Size (MBTUH)	Electric Heat Kit (kW)
12	5
18	10
24	12.5
25	15
30	17.5
31	17.5
36	20
37	20
42	20
48	25
60	25

Table: Maximum allowable kW Electric Heat Kits that can be field installed for their respective Air Handler Size.

1. Disconnect all power supplies.
2. Remove the air handler access panel.
3. Route the field supply wires to the air handler electrical connection box.
4. Using UL listed wire nuts, connect the field supply wires to the air handler; black-to-black, and yellow-to-yellow (240V) or white-to-white (120V), as shown in Figure 8.
5. Connect ground wire to ground terminal marked "GND."
6. Replace the air handler access panel.

! **WARNING** !



Electrical Shock Hazard

Disconnect all power supplies before servicing.

Replace all parts and panels before operating.

Failure to do so can result in death or electrical shock.

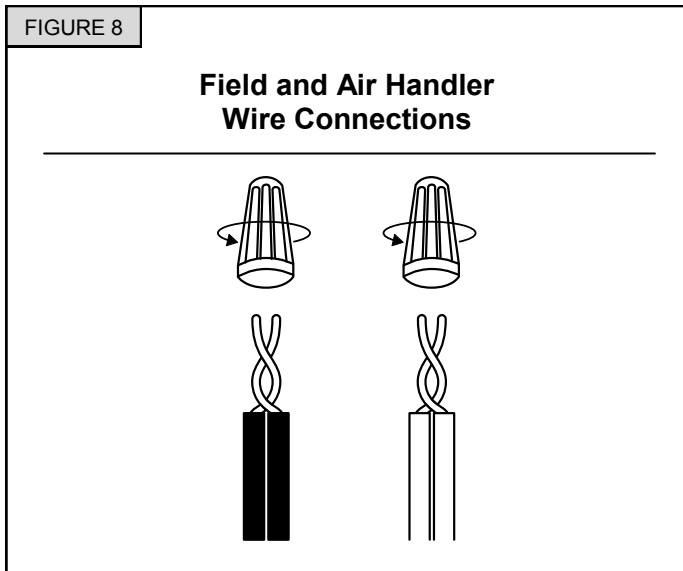

THERMOSTAT CONNECTIONS

3-Speed Motor (Electric Heat)

Maximum allowable current draw from power-stealing thermostats or other accessories is 18 mA. Exceeding this value may cause the Air Handler control board to operate abnormally.

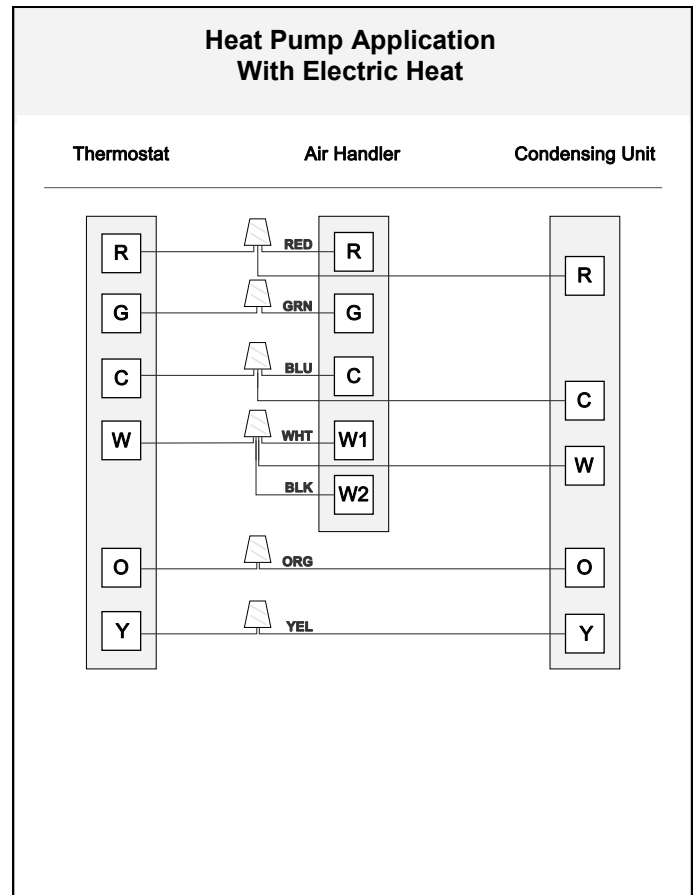
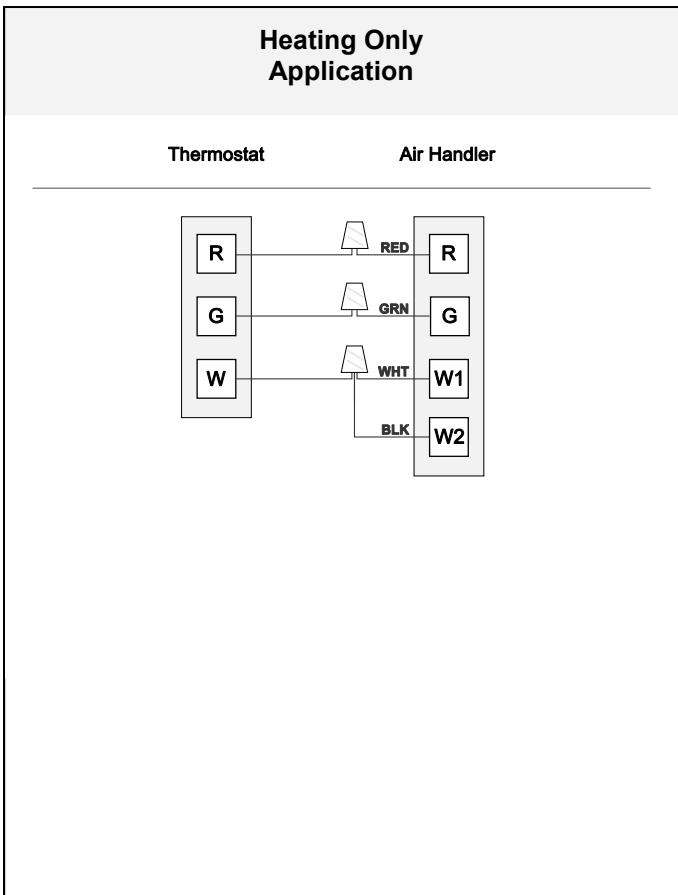
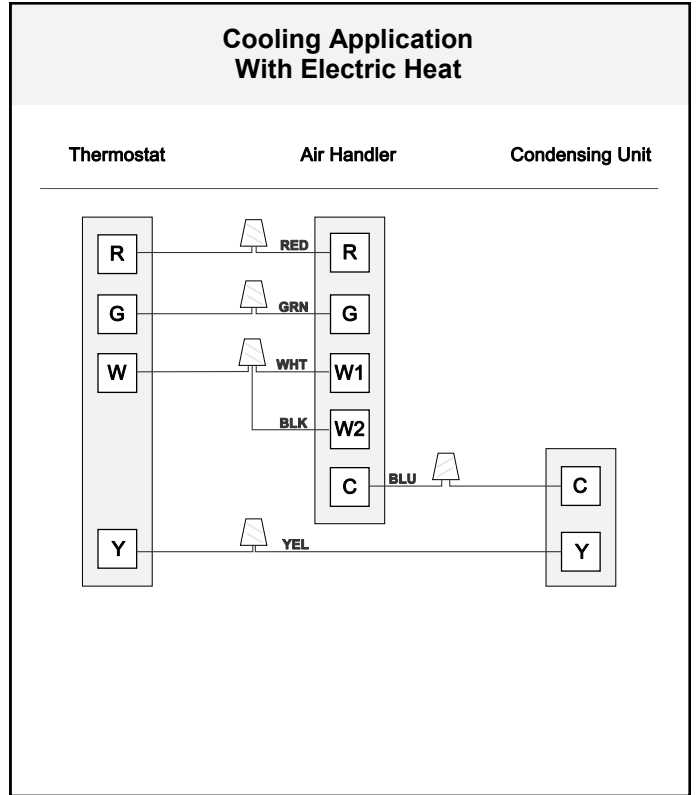
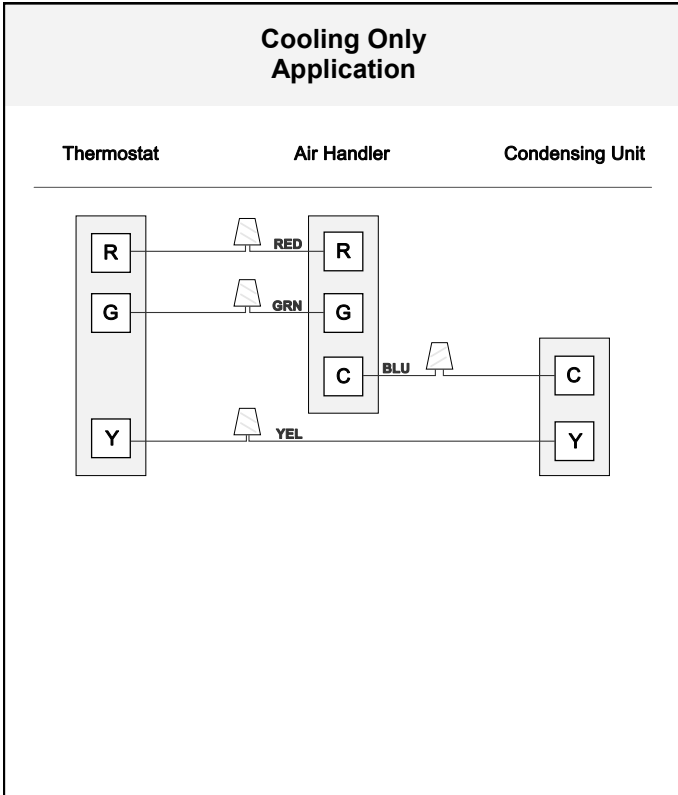

THERMOSTAT CONNECTIONS

3-Speed Motor & Variable-Speed High Efficiency ECM Motor (Hot Water Heat)

Maximum allowable current draw from power-stealing thermostats or other accessories is 18 mA. Exceeding this value may cause the Air Handler control board to operate abnormally.

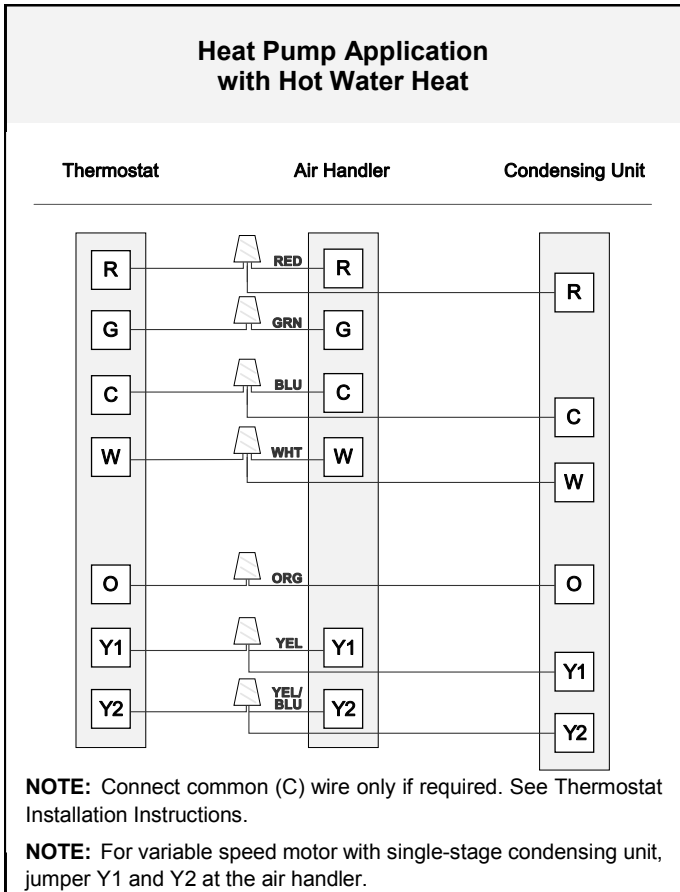
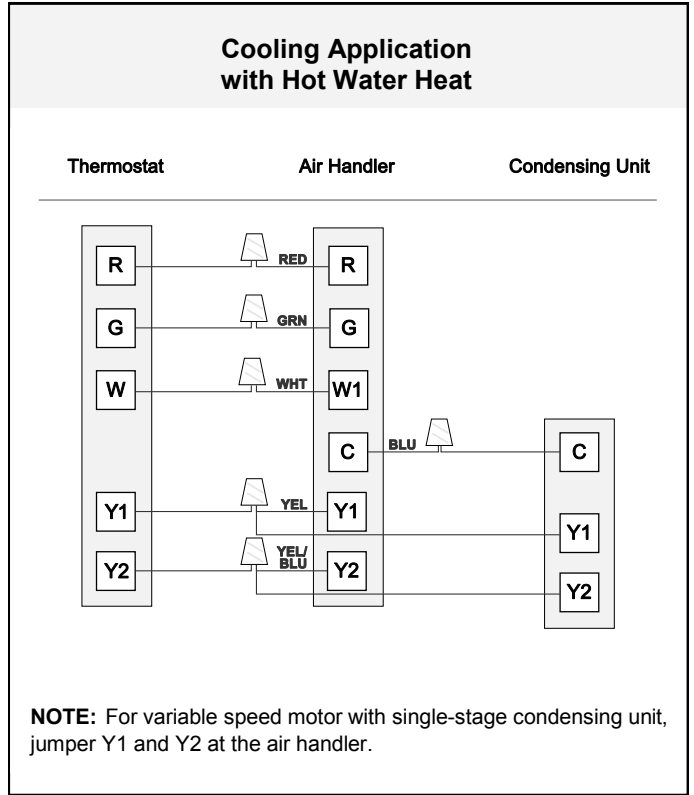
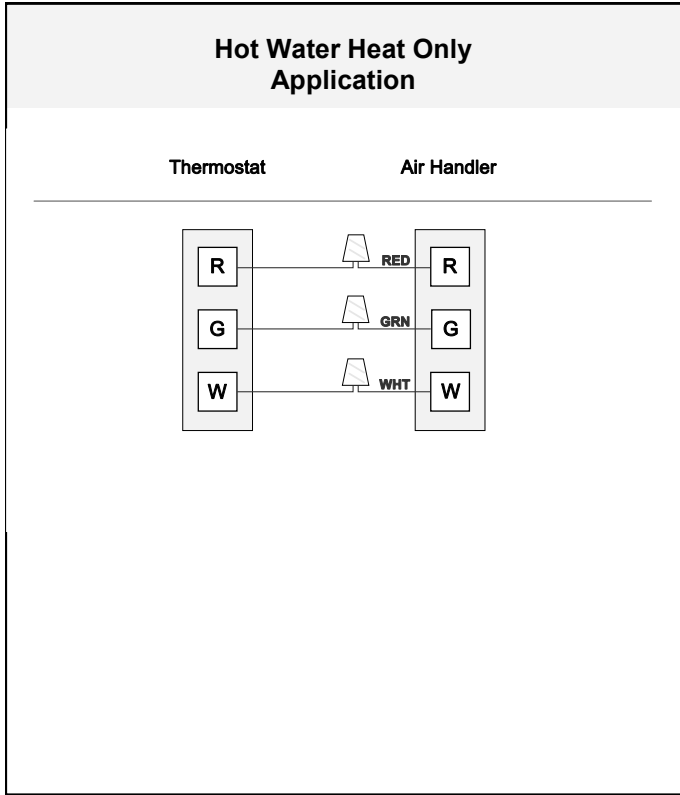

THERMOSTAT CONNECTIONS

Variable-Speed High Efficiency ECM Motor (Electric Heat)

Maximum allowable current draw from power-stealing thermostats or other accessories is 18 mA. Exceeding this value may cause the Air Handler control board to operate abnormally.

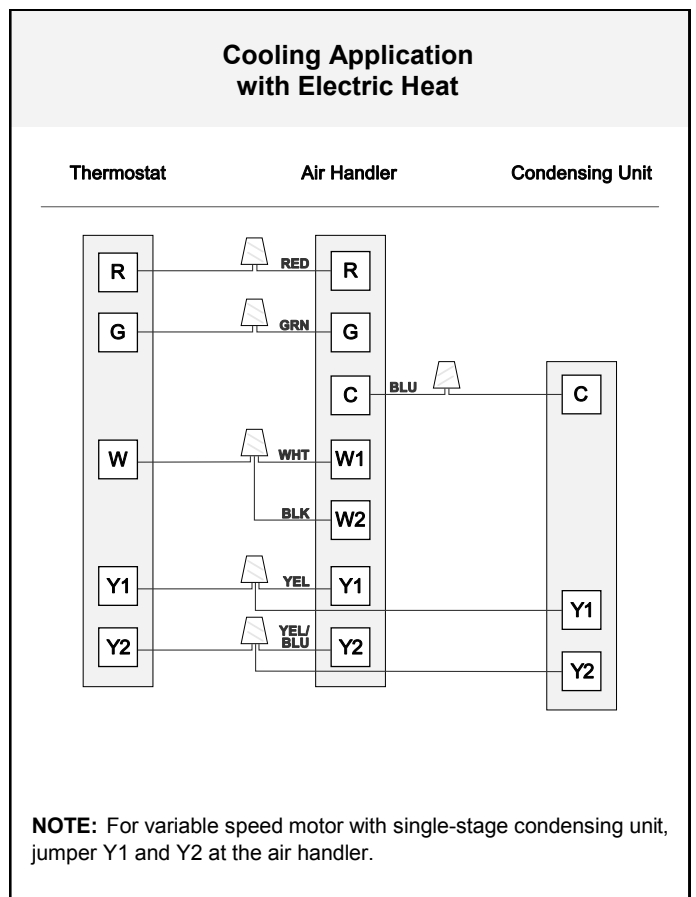
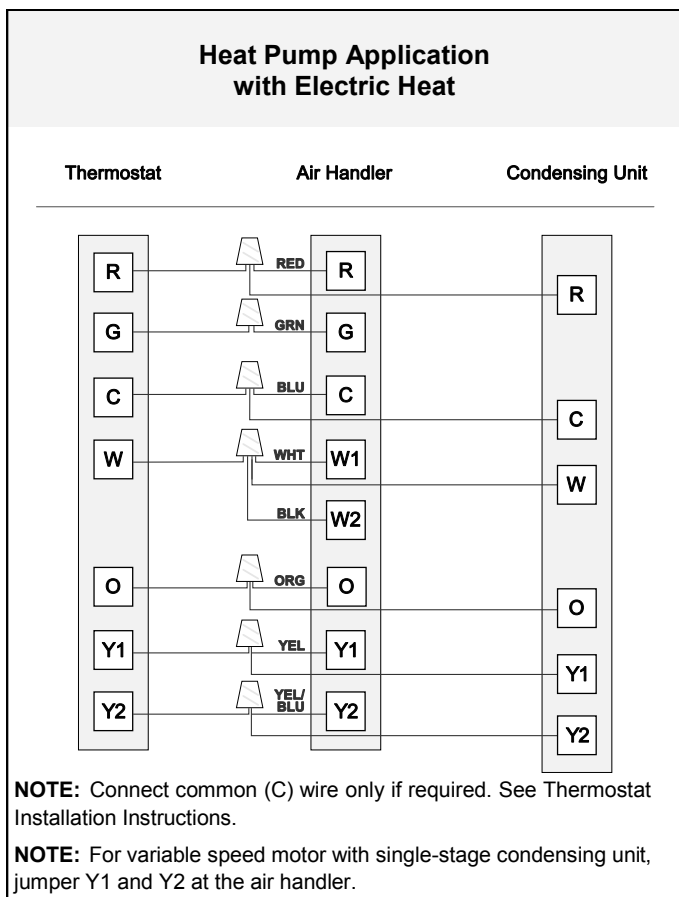
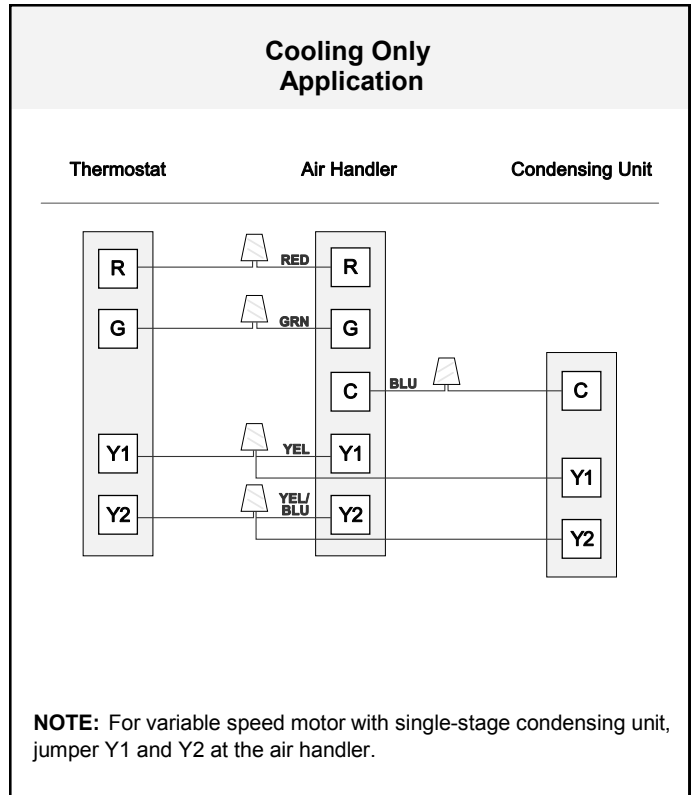
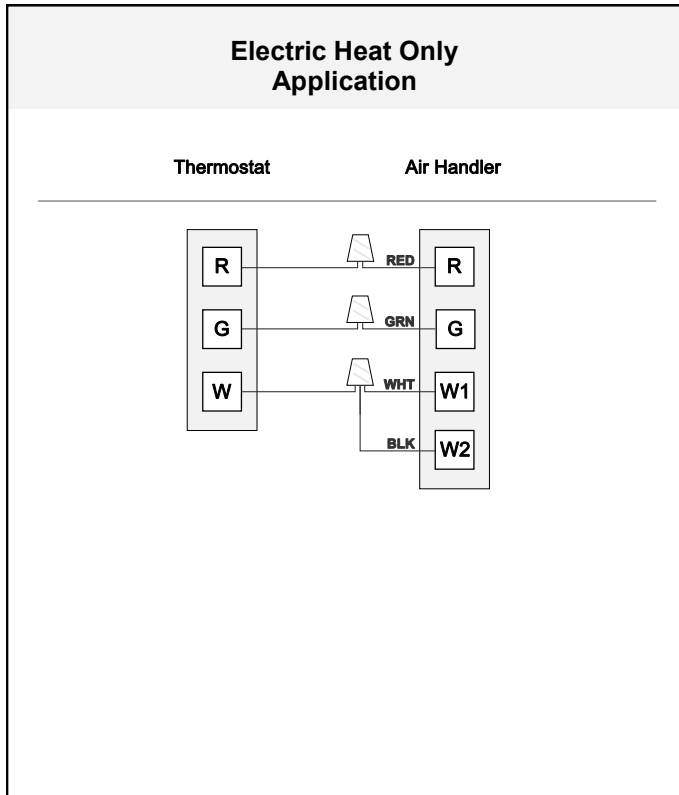

WIRING DIAGRAM

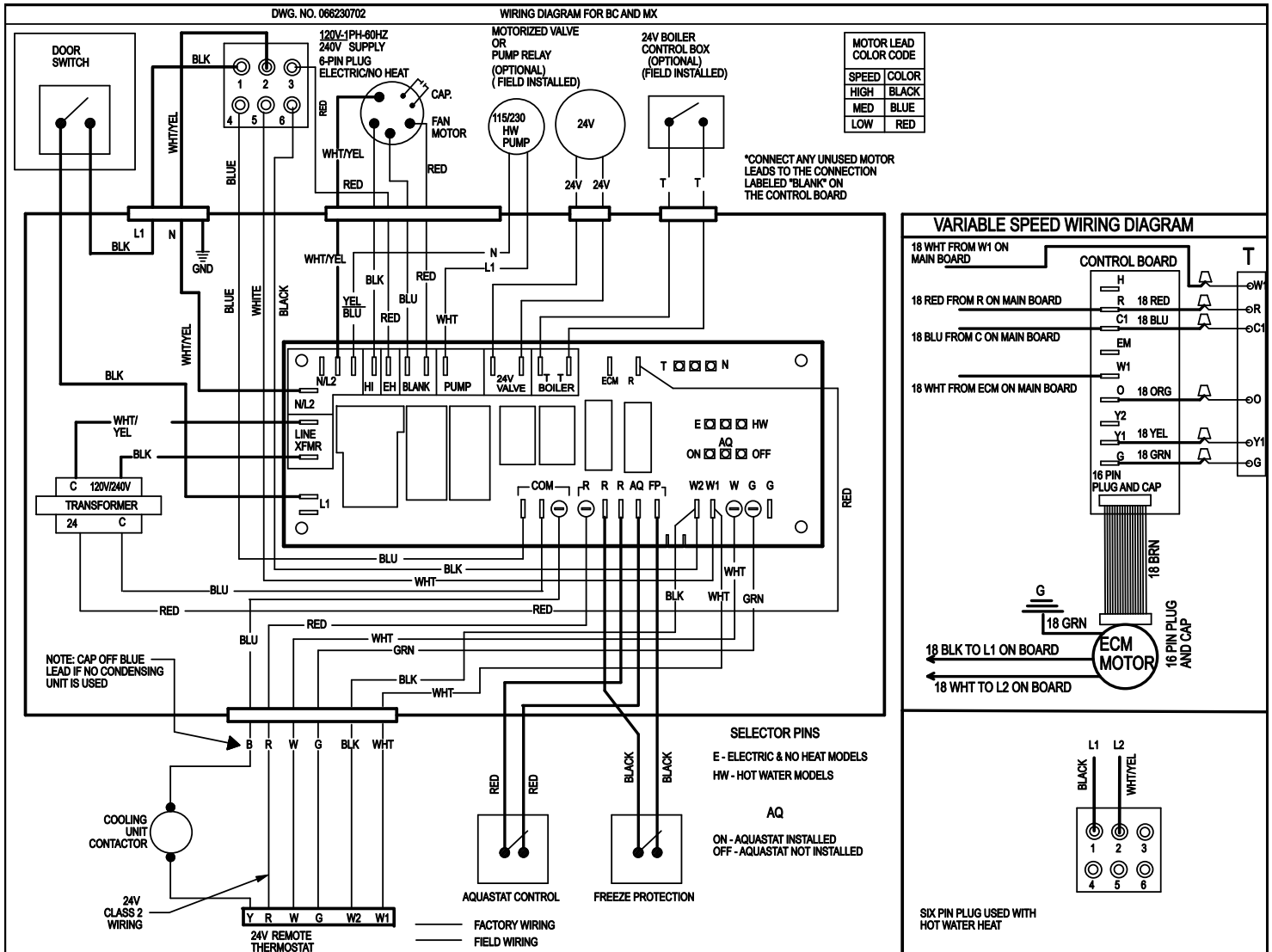

NOTE: 6-Pin Plug serves as connection for electric heat kits to control board.

If your unit is equipped with a multi-function control board, then for electric heat installations insure that heat selector pin is set to "E".

BLOWER PERFORMANCE DATA

3-Speed Motor

All data is given while air handler is operating with a dry DX coil and air filter installed.

Speeds marked in **bold with asterisk*** are the factory speed settings for both heating and cooling. Heating speeds should not be reduced below factory setting.

208/240V Motor		Airflow (CFM) vs. External Static Pressure (inches W.C.)									
Unit Size (MBUTH)	Fan Speed Setting	Electric Heat Models					Water Heat Models				
		0.10	0.20	0.30	0.40	0.50	0.10	0.20	0.30	0.40	0.50
12	*Low	640	635	619	584	513	608	603	588	555	487
	Med	907	861	808	743	659	862	818	768	706	626
	High	961	914	854	786	703	913	868	811	747	668
18	*Low	640	635	619	584	513	608	603	588	555	487
	Med	907	861	808	743	659	862	818	768	706	626
	High	961	914	854	786	703	913	868	811	747	668
24	Low	640	635	619	584	513	608	603	588	555	487
	Med	907	861	808	743	659	862	818	768	706	626
	*High	961	914	854	786	703	913	868	811	747	668
25	Low	757	725	673	602	549	719	689	639	572	522
	*Med	893	862	823	746	660	848	819	782	709	627
	High	1111	1059	1005	964	904	1055	1006	955	916	859
30	Low	757	725	673	602	549	719	689	639	572	522
	Med	893	862	823	746	660	848	819	782	709	627
	*High	1111	1059	1005	964	904	1055	1006	955	916	859
31	*Low	1221	1187	1099	1080	1018	1160	1128	1044	1026	967
	Med	1329	1267	1208	1146	1073	1263	1204	1148	1089	1019
	High	1383	1317	1260	1188	1103	1314	1251	1197	1129	1048
36	Low	1221	1187	1099	1080	1018	1160	1128	1044	1026	967
	*Med	1329	1267	1208	1146	1073	1263	1204	1148	1089	1019
	High	1383	1317	1260	1188	1103	1314	1251	1197	1129	1048
37	*Low	1251	1263	1253	1214	1133	1188	1200	1190	1153	1076
	Med	1396	1397	1371	1309	1215	1326	1327	1302	1244	1154
	High	1731	1668	1588	1487	1379	1644	1585	1509	1413	1310
42	Low	1251	1263	1253	1214	1133	1188	1200	1190	1153	1076
	*Med	1396	1397	1371	1309	1215	1326	1327	1302	1244	1154
	High	1731	1668	1588	1487	1379	1644	1585	1509	1413	1310
48	Low	1627	1582	1513	1432	1328	1546	1503	1437	1360	1262
	*Med	1801	1706	1620	1513	1398	1711	1621	1539	1437	1328
	High	1854	1748	1656	1552	1448	1761	1661	1573	1474	1376
60	Low	1640	1583	1552	1497	1439	1558	1504	1474	1422	1367
	*Med	1961	1892	1814	1704	1616	1863	1797	1723	1619	1535
	High	2072	2001	1889	1789	1643	1968	1901	1795	1700	1561

120V Motor		Airflow (CFM) vs. External Static Pressure (inches W.C.)									
Unit Size (MBUTH)	Fan Speed Setting	Electric Heat Models					Water Heat Models				
		0.10	0.20	0.30	0.40	0.50	0.10	0.20	0.30	0.40	0.50
12	*Low	499	493	470	437	401	458	445	431	402	368
	Med	671	636	611	557	490	631	611	581	543	485
	High	727	715	675	631	540	725	691	650	602	544
18	*Low	499	493	470	437	401	458	445	431	402	368
	Med	671	636	611	557	490	631	611	581	543	485
	High	727	715	675	631	540	725	691	650	602	544
24	Low	687	584	579	549	487	588	580	564	537	471
	Med	889	847	795	731	666	771	747	710	671	600
	*High	952	896	847	780	697	893	848	801	714	639
25	Low	819	812	805	782	735	781	777	773	760	741
	*Med	1015	1004	986	961	930	989	989	983	967	942
	High	1155	1149	1122	1090	1039	1095	1089	1072	1049	1020
30	Low	819	812	805	782	735	781	777	773	760	741
	Med	1015	1004	986	961	930	989	989	983	967	942
	*High	1155	1149	1122	1090	1039	1095	1089	1072	1049	1020
31	*Low	1121	1110	1099	1065	1023	1118	1111	1097	1060	1013
	Med	1302	1278	1233	1197	1144	1275	1261	1222	1168	1112
	High	1448	1391	1359	1298	1223	1355	1330	1317	1267	1196
36	Low	1121	1110	1099	1065	1023	1118	1111	1097	1060	1013
	*Med	1302	1278	1233	1197	1144	1275	1261	1222	1168	1112
	High	1448	1391	1359	1298	1223	1355	1330	1317	1267	1196
37	*Low	1190	1122	1052	1028	1003	1072	1011	947	926	903
	Med	1437	1355	1270	1241	1212	1351	1274	1194	1167	1139
	High	1449	1429	1389	1344	1298	1361	1342	1305	1263	1219
42	Low	1345	1331	1302	1282	1257	1153	1144	1144	1135	1135
	*Med	1681	1615	1587	1521	1487	1494	1445	1431	1395	1342
	High	1788	1727	1674	1603	1529	1666	1590	1571	1511	1469
48	Low	1568	1527	1502	1433	1397	1518	1440	1409	1383	1338
	*Med	1775	1724	1672	1563	1505	1652	1575	1541	1506	1459
	High	1881	1834	1765	1693	1597	1736	1668	1614	1564	1524
60	Low	1662	1650	1643	1614	1568	1646	1642	1639	1630	1606
	*Med	1853	1840	1813	1746	1675	1833	1826	1820	1766	1702
	High	2085	2038	1990	1916	1839	2065	2029	1981	1918	1847

BLOWER PERFORMANCE DATA

Variable-Speed High Efficiency ECM Motor

Unit Size (MBUTH)	Operating Mode	Thermostat Terminals						Control Board Taps							
		X = Energized Terminal						Cool				Heat			
		HUM	EM	W1	Y1	Y2	G	A CFM	B CFM	C CFM	D CFM	A CFM	B CFM	C CFM	D CFM
25	Continuous Blower						X	500	400	350	350				
	Hi Cooling / HP Heating	**			X	X		1000	800	700	600				
	Low Cooling/ HP Heating				X			700	560	490	420				
	Aux. Heat			X	X	X		***	***	***	***	1000	800	700*	600*
	Emer. Heat		X	X				***	***	***	***	1000	800	700*	600*
30, 31	Continuous Blower						X	600	500	400	350				
	Hi Cooling / HP Heating	**			X	X		1200	1000	800	600				
	Low Cooling/ HP Heating				X			840	700	560	420				
	Aux. Heat			X	X	X		***	***	***	***	1200	1100	1100	1100
	Emer. Heat		X	X				***	***	***	***	1200	1100	1100	1100
37	Continuous Blower						X	600	500	400	350				
	Hi Cooling / HP Heating	**			X	X		1200	1000	800	600				
	Low Cooling / HP Heating				X			840	700	560	420				
	Aux. Heat			X	X	X		***	***	***	***	1200	1100*	1100*	1100*
	Emer. Heat		X	X				***	***	***	***	1200	1100*	1100*	1100*
42	Continuous Blower						X	800	700	600	500				
	Hi Cooling / HP Heating	**			X	X		1600	1400	1200	1000				
	Low Cooling / HP Heating				X			1120	980	840	700				
	Aux. Heat			X	X	X		***	***	***	***	1600	1400	1200*	1100*
	Emer. Heat		X	X				***	***	***	***	1600	1400	1200*	1100*
48	Continuous Blower						X	800	700	600	500				
	Hi Cooling / HP Heating	**			X	X		1600	1400	1200	1000				
	Low Cooling / HP Heating				X			1120	980	840	700				
	Aux. Heat			X	X	X		***	***	***	***	1600	1400*	1200*	1100*
	Emer. Heat		X	X				***	***	***	***	1600	1400*	1200*	1100*
60	Continuous Blower						X	900	800	700	600				
	Hi Cooling / HP Heating	**			X	X		1850	1600	1400	1200				
	Low Cooling / HP Heating				X			1295	1120	980	840				
	Aux. Heat			X	X	X		***	***	***	***	1850	1600	1400*	1200*
	Emer. Heat		X	X				***	***	***	***	1850	1600	1400*	1200*

* This CFM is not approved for use with the highest kW heater size.

** Humidistat will reduce cooling airflow by 10% in high humidity.

***Airflow is the greater of the COOL and HEAT values when both electric heat and heat pump are operating.

Adjust tap (+) will increase airflow by 10%, while tap (-) will decrease airflow by 12%.

Adjust tap TEST will cause the motor to run at 70% of full airflow. Use this for troubleshooting only.

VARIABLE SPEED CONTROL BOARD

The motor control board that provides selection also features LED indicators that display operating mode, humidity control and airflow CFM. In addition, thermostat signals for emergency heat (EM), aux, heat (W1), reversing valve (O), compressor stage 1 (Y1), compressor stage 2 (Y2) and blower (G) are all indicated by lit LED's on this board. If a humidistat is used, the dehumidify LED will light when the humidistat opens and the motor runs at reduced airflow. The control board also has a CFM LED that displays the operating CFM. This red LED

flashes once for each 100 CFM. For example, if the operating CFM is 1200, the CFM LED will flash 12 times, then pause before repeating the 12-flash pattern.

! **WARNING** !



Electrical Shock Hazard

Disconnect all power supplies before servicing.

Replace all parts and panels before operating.

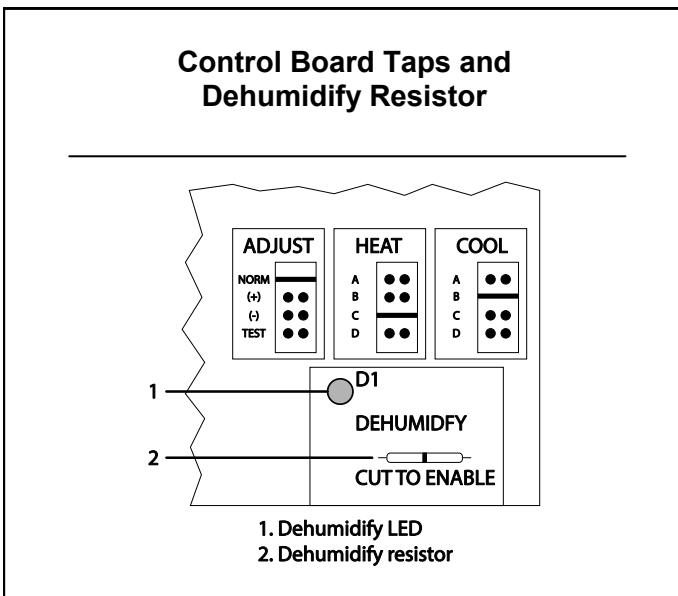

AIR HANDLER CHECKS

Check Blower Operation

1. Set thermostat to FAN ON.
2. The indoor blower should come on.

Check Hot Water Heat (if used)

1. Set thermostat to call for auxiliary heat (approximately 5°F above ambient temperature). The indoor blower and auxiliary heat should come on together.
2. Set the thermostat so it does not call for heat.

Check Airflow

Cooling Blower Speed:

- For proper cooling operation, the airflow through the indoor coil should be between 350 and 450 CFM per ton of cooling capacity (350 - 450 CFM per 12,000 BTU/HR) based on the rating of the outdoor unit.
- The cooling blower speed is factory configured to provide correct airflow for an outdoor unit that matches the maximum cooling capacity rating of the air handler.
- If the outdoor unit is smaller than the maximum cooling capacity rating for the air handler, the cooling blower speed may need to be changed. Refer to "Blower Performance Chart."

IMPORTANT: The cooling blower speed must be set to provide a minimum of 350 CFM airflow per ton (12,000 BTU/HR) of outdoor cooling capacity.

To change blower speed for 3-Speed Motor: (Refer to "Wiring Diagram – 3-Speed Motor.")

As shipped from the factory, the cooling and heating speeds are the same. In some cases it may be necessary to change speed for cooling or heating. To do so, use the following procedure:

1. Disconnect all power supplies.
2. Remove the air handler access panel.
3. Locate the motor wire running from the blower motor to the control board motor tap.
4. Remove the motor wire from the control board and replace with desired motor speed wire from P9 or P10 in the Blank area of board.
5. Replace all panels.
6. Reconnect power.

HOT WATER COIL INSTALLATION

ADP hydronic air handlers (certified to NSF 372) can be used with potable water systems and are shipped with or without circulating pumps. Kits are also available. Refer to pipe and pump sizing in the Air Handler's Engineering & Specification Guide for units with external pumps.

Proper water heating sizing should consider both the gallon capacity AND the BTU input of the water heater.

To determine water heater gallon capacity:

A minimum 40 gallon high recovery and/or high efficiency gas or oil fired water heater is recommended. The following volume -sizing guide is satisfactory in most areas.

1. Determine Volume

CFM	Water Heater Requirements
600-800	40 gallons
1000-1200	40 gallons
1400-1600	Either 2 -40 gallons piped together, 1 high input 50 gallon (63,000 to 75,000 Btu/hr input), or 1 -72 (or higher) gallon tank.
2000	Any combination of water heaters piped together with a total output of 105,000 Btu/hr.

2. Determine water heater BTU/HR input requirements

Assume water heater recovery efficiency of 76%

BTU/HR input=

Mild climates: structure heat loss X 1.51

Cold climates: structure heat loss X 1.58

NOTICE

If connecting to tankless water heater, the circulating pump may need to be changed to get proper flow. Refer to water heater instructions for details.

NOTICE

Use copper pipe and fittings. Other compatible piping and fitting materials may be used only if approved by local code authority and only if installed following the manufacturer's application and installation instructions.

NOTICE

Solder joints on domestic water lines are to be made with NO-LEAD SOLDER.

NOTICE

The State of Mass requires the use of a pump timer on domestic water applications to periodically circulate water during the off cycle. This pump timer requirement is a standard factory installed feature on all B Series Air Handlers. A 50' maximum distance between water heater and air handler is also required.

NOTICE

The factory installed freeze protection on all air handlers with hot water coils is designed to protect the coil from freezing. Installer must protect water piping from freezing when in unconditioned spaces such as attics, crawl spaces, or within structures that may be unoccupied during freezing conditions. Insulating piping or using a water-glycol solution may help prevent pipe freezing.

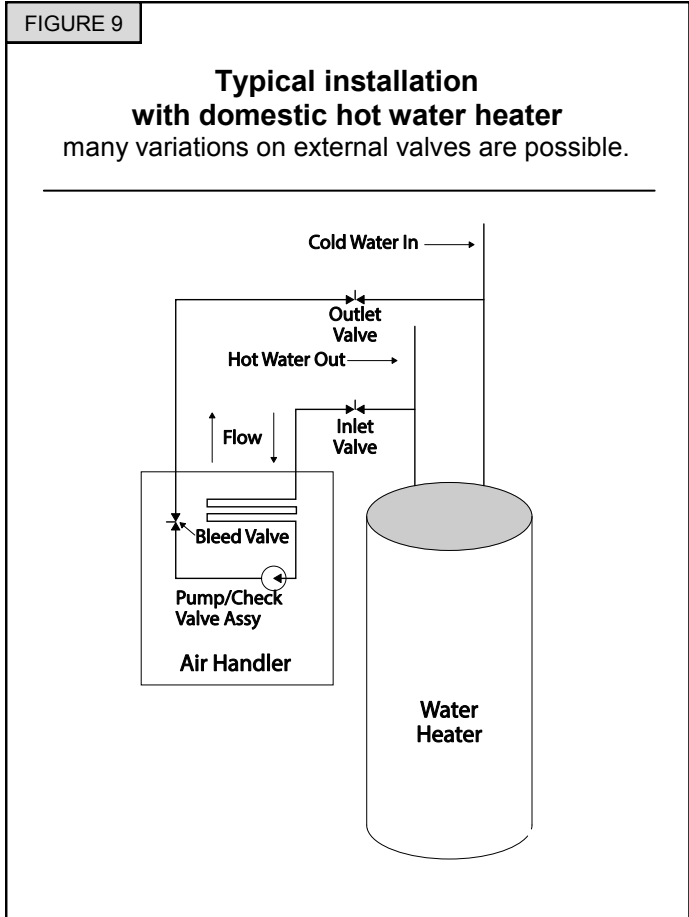

HOT WATER COIL WATER FLUSHING

Flushing the hot water coil prior to start up is required to remove any residual material from the installation or manufacturing processes as well as remove any air from the system.

A bleed valve comes standard on all air handlers with factory installed circulating pumps. If using an external circulating pump, please use an external purge valve or other mechanism to flush hot water coil after installation. Take precautions while

⚠ **CAUTION** ⚠

Do not engage pump until the flushing process is completed. Running pump dry will cause damage.

⚠ **CAUTION** ⚠

Follow piping manufacturer's requirements for any additional required flushing or cleaning of coil and piping if using non-copper piping.

flushing the air handler to keep the multi-function control board and other electrical components from getting wet. Hot water is preferred for flushing.

Flushing is a 3-step process. Use a bucket or hose to dispose of water from the bleed valve during flushing (refer to Figure 9).

First, flush the return line by closing the inlet valve (supply) and opening the outlet valve (return). Open the bleed valve. Close the bleed valve when flushing is complete.

Second, flush the supply line and coil by closing the outlet valve (return) and opening the inlet valve (supply). Open the bleed valve. Close the bleed valve when flushing complete.

Third, apply power to the air handler. Open inlet and outlet valves. Engage pump and open bleed valve. Verify proper flow direction—inlet should become warm before outlet. Close the bleed valve when flushing is complete.

Operate pump for 5 minutes immediately after flushing system to purge remaining air from the pump bearing chamber.

SEQUENCE OF OPERATIONS

The Blower Door Safety Switch circuit must be complete for all Sequence of Operations to take place.

FIGURE 10

Drawing of Multi-function Control Board, installed in all B Series Air Handlers

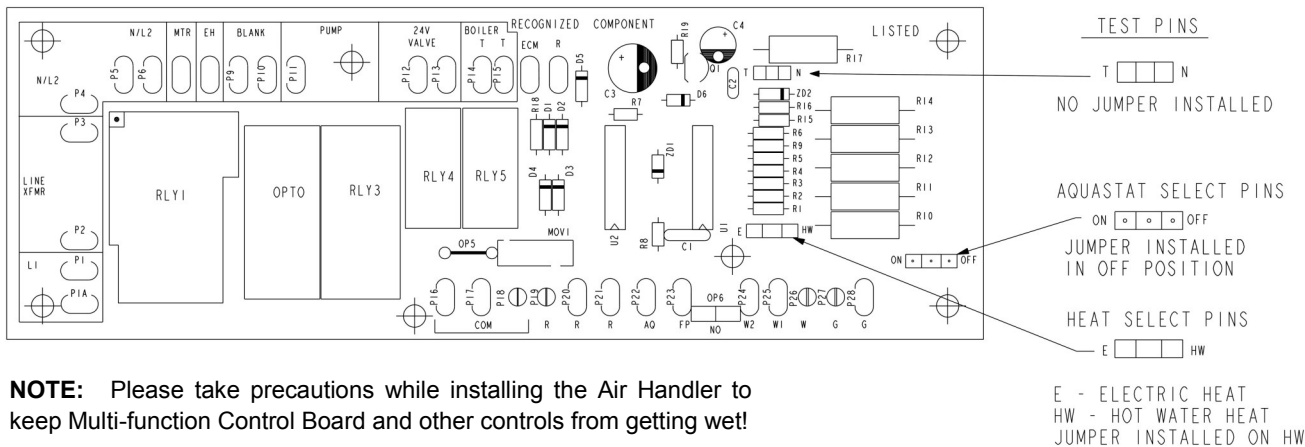

Cooling

When the thermostat calls for cooling, the circuit between R and G is completed, and the blower **relay** is energized. The Normally Open contacts close, causing the indoor blower motor to operate. The circuit between R and Y is also completed; this circuit closes the contactor in the outdoor fan motor. Circuit R and O or R and B energizes the reversing valve, switching it to the cooling position (depends on outdoor unit). Air Handler blower turns off 45 seconds after the thermostat stops calling for cooling.

Heating (electric heat only)

When the thermostat calls for heat, the circuit between R and W is completed, and the heater sequencer is energized. A time

delay follows before the heating elements and the indoor blower motor comes on. Units with a second heat sequencer can be connected with the first sequencer to W on the thermostat sub base or connected to a second stage on the sub base. Air Handler blower turns off 30 seconds after the thermostat stops calling for heating.

Heating (heat pump with electric heat)

When the thermostat calls for heat, the circuits between R and Y and R and G are completed. Circuit R-Y energizes the contactor starting the outdoor fan motor and the compressor. Circuit R and G energizes the blower relay starting the indoor blower motor. Circuit R and O or R and B energizes the reversing valve, switching it to the heating position (depends on outdoor unit). If the room temperature should continue to

SEQUENCE OF OPERATIONS

fall, the circuit between R and W1 is completed by the second stage heat room thermostat. Circuit R-W1 energizes a heat sequencer. The completed circuit will energize supplemental electric heat (if applicable). Units with a second heater sequencer can be connected with the first sequencer to W1 on the thermostat or connected to a second heating stage W2 on the thermostat sub base. Air Handler blower turns off 30 seconds after the thermostat stops calling for heating.

Emergency Heat (heat pump with electric heat)

If selector switch on thermostat is set to the emergency heat position, the heat pump will be locked out of the heating circuit, and all heating will be electric heat (if applicable). A jumper should be placed between W2 and E on the thermostat subbase so that the electric heat control will transfer to the first stage heat on the thermostat. This will allow the indoor blower to cycle on and off with the electric heat when the fan switch is in the AUTO position.

Heating (hot water heat only)

When the thermostat calls for heat, the circuit between R and W is completed, activating the hot water circulating pump. If a field installed circulating pump is being used the control board can still be wired to the pump directly or to an isolation valve supplying hot water to the Air Handler using the control board's 24V relay switch. A similar 24 V dry switching relay labeled TT can be used to activate a boiler or water heater valve. After the circuit between R & W are completed

Units with Factory Installed Aquastats- The water temperature inside the hot water coil must reach 130 deg. F before the circuit between R and G are complete activating the indoor blower motor. To deactivate a factory installed aquastat simply move the selector pin on the multi-function control board (See drawing above) from the on position to the off position.

Units without Factory Installed Aquastats or Deactivated Aquastats- A time delay of 60 seconds follows before the circuit between R and G are complete activating the indoor blower motor.

The Air Handler fan will turn off 30 seconds after the Thermostat stops calling for heating.

Heating (heat pump with hot water heat)

When the thermostat calls for heat, the circuits between R and Y and R and G are completed. Circuit R-Y energizes the contactor starting the outdoor fan motor and the compressor. Circuit R and

G energizes the blower relay starting the indoor blower motor. Circuit R and O or R and B energizes the reversing valve, switching it to the cooling position (depends on outdoor unit). If the room temperature should continue to fall, the second stage heat room thermostat completes the circuit between R and W. If a field installed circulating pump is being used the control board can still be wired to the pump directly or to an isolation valve supplying hot water to the Air Handler using the control board's 24V relay switch. A similar 24 V dry switching relay labeled TT can be used to activate a boiler or water heater valve. After the circuit between R & W are completed

Units with Factory Installed Aquastats- The water temperature inside the hot water coil must reach 130 deg. F before the circuit between R and G are complete activating the indoor blower motor. To deactivate a factory installed aquastat simply move the selector pin on the multi-function control board (See drawing above) from the on position to the off position.

Units without Factory Installed Aquastats or Deactivated Aquastats— a time delay of 60 seconds follows before the circuit between R and G are complete activating the indoor blower motor.

The Air Handler fan will turn off 45 seconds after the Thermostat stops calling for heating.

Freeze Protection (hot water heat)

If the temperature of the water within the hot water coil were to drop below 40°F the circuit between R and W is completed, activating the hot water circulating pump, external circulating pump or isolation valve. Once the water temperature rises above 70°F the circuit between R and W is opened and hot water will stop circulating within the hot water coil.

To prevent the freeze protection from activating the water circulating pump when in cooling mode, move freeze stat to far left or far right of water coil, and insulate with foam tape insulation.

Pump Timer (hot water heat)

The State of Massachusetts requires the use of a pump timer on domestic water applications to periodically circulate water during the off cycle. This pump timer requirement is a standard factory installed feature on all B Series Air Handlers. The Pump timer activates the circulating pump or isolation valve for one minute every six hours by completing the circuit between R and W. The Pump timer is skipped while the outdoor compressor is operating.

AIR HANDLER MAINTENANCE

At the beginning of each heating season the unit should be serviced by a qualified installer or servicing agency.

ASSISTANCE OR SERVICE

If you need further assistance, you may contact us at this address with any questions or concerns. Please include a daytime phone number in your correspondence.

Advanced Distributor Products
1995 Air Industrial Park Road, Grenada, MS 38901
www.adpnow.com

WARRANTY



Air Handler Limited Warranty – Standard 5 Year

(Applies only to product installed within the United States or Canada)

Term of Standard Warranty: Advanced Distributor Products (ADP) warrants that products sold shall be of merchantable quality, free of defects in material and workmanship, under normal use and service, for a period of five (5) years from the date of installation, **not** to exceed six (6) years from the date of manufacture. Use of this product other than in a residential application will limit the warranted term to a period of (1) year from the date of installation, not to exceed two (2) years from the date of manufacture.

Warranty Procedure: Warranty parts should be replaced by a qualified local contractor or dealer and will require the following information: model number, serial number, date of installation and an accurate description of the problem. Contractor or dealer will contact a local ADP distributor for replacement parts.

Replacement Parts: If, during the term of this warranty, a warranted part fails, ADP will either provide a replacement part free of charge, or may at its option, grant a credit for the original purchase price of the defective article to a distributor of ADP products. ADP may require the return of a defective article for factory inspection to verify and/or determine the root cause of the failure. Covered components include all parts of this unit except for the following **excluded components**, which are not covered by this warranty: cabinet, cabinet pieces, wiring and wiring harnesses.

Care of Equipment: For this warranty to apply, ADP product must be properly installed, operated, and maintained in accordance with the installation, operation and maintenance instructions provided with each unit. Unauthorized alteration of ADP product may void this warranty.

Conditions of Warranty: Replacement parts furnished under this warranty will be warranted for the balance of the original warranty term of the unit and will not serve to extend the original term. This warranty is void if the ADP product is removed from the original installation site. This warranty does not apply to damage caused by shipping, misuse, mishandling or damage caused by floods, winds, fires, lightning, or exposure to corrosive elements/environments (such as salt, chlorine, fluorine or other damaging chemicals).

Limitations of Warranty: The costs of refrigerant, refrigerant reclamation, miscellaneous material and labor charges for diagnostics, servicing or replacing parts are not covered. ADP shall have no liability for expenses incurred for repairs without prior, written authorization from ADP. No purchaser, distributor, dealer, representative, agent, person, firm or corporation has authority to alter, add to or modify this warranty, either orally or in writing.

No Other Warranties: ADP makes no warranty, express or implied, of fitness for any particular purpose, or of any other nature whatsoever, with respect to products manufactured or sold by ADP hereunder, except as specifically set forth above and on the face hereof. Any implied warranty of merchantability or fitness for a particular purpose on this product is limited in duration to the duration of this warranty. Some states and provinces do not allow limitations on how an implied warranty lasts, so the above limitation may not apply to you. It is expressly understood and agreed that ADP shall not be liable to buyer, or any customer of buyer, for direct or indirect, special, incidental, consequential or penal damages, or for any expenses incurred by reason of the use or misuse by buyer or third parties of said products. To the extent said products may be considered "consumer products", as defined in Sec. 101 of the Magnuson-Moss Warranty-Federal Trade Commission Improvement Act, ADP makes no warranty of any kind, express or implied, to "consumers," except as specifically set forth above on the face hereof. The foregoing is in lieu of all other warranties, express or implied, notwithstanding the provisions of the Uniform Commercial Code, the Magnuson-Moss Warranty-Federal Trade Commission Improvement Act, or any other statutory or common law, federal or state.

2175 West Park Place Boulevard
Stone Mountain, Georgia 30087
www.adpnow.com