

Installation Instructions

F Series

Premier Low Profile Air Handlers

Electric or No Heat, with available 5-Speed High Efficiency ECM Motor

Table of Contents

AIR HANDLER SAFETY	1	Verify Orifice Size	7
INSTALLATION REQUIREMENTS	2	Connect Refrigerant Lines	7
Tools and Parts	2	Refrigerant Charging Instructions	8
Outdoor System Requirements	2	Electrical Connections –	
Location Requirements	2	Models without Factory Installed Electric Heat	8
Installation Configurations	3	Electrical Connections –	
Drain Pan Connections	4	Models with Factory Installed Electric Heat	9
Electrical Requirements	5	Blower Performance	15
Ductwork Requirements	5	SEQUENCE OF OPERATION	17
INSTALLATION INSTRUCTIONS	5	AIR HANDLER MAINTENANCE	17
Inspect Shipment	5	ASSISTANCE OR SERVICE	17
Install Condensate Drain	6	WARRANTY	18
Install Ductwork	7		



AIR HANDLER SAFETY

Your safety and the safety of others are very important.

We have provided many important safety messages in this manual and on your appliance. Always read and obey all safety messages.



This is the safety alert symbol.

This symbol alerts you to potential hazards that can kill or hurt you and others.

All safety messages will follow the safety alert symbol and either the word "DANGER" or "WARNING." These words mean:



You can be killed or seriously injured if you don't immediately follow instructions.



You can be killed or seriously injured if you don't follow instructions.

All safety messages will tell you what the potential hazard is, tell you how to reduce the chance of injury, and tell you what can happen if the instructions are not followed.

INSTALLATION REQUIREMENTS

These instructions are intended as a general guide only and do not supersede any national or local codes in any way. Compliance with all local, state, or national codes pertaining to this type of equipment should be determined prior to installation.

Read this entire instruction manual, as well as the instructions supplied in separate equipment, before starting the installation.

All models are designed for indoor installation only.

The installation of the air handler, field wiring, warm air ducts, etc. must conform to the requirements of the National Electrical Code, ANSI/NFPA No. 70 (latest edition) in the United States, and any state laws, and local ordinances (including plumbing or wastewater codes). Local authorities having jurisdiction should be consulted before installation is made. Such applicable regulations or requirements take precedence over the general instructions in this manual.

Install the conditioned air plenum, ducts and air filters (not provided) in accordance with NFPA 90B Standard for the Installation of Warm Air Heating and Air-Conditioning Systems (latest edition).

Some models are configured for upflow air discharge only, and some models are configured for upflow or horizontal left-hand air discharge.

Do not remove the cabinet knockouts until it has been determined which knockouts need to be removed for the installation.

Select the final installation position that best suits the site conditions. Consider required clearances, space, routing requirements for refrigerant line, condensate disposal, filters, ductwork, wiring, and accessibility for service. Refer to the air handler rating plate on the air handler for specific information.

Tools and Parts Needed

Assemble the required tools and parts before starting installation. Read and follow the instructions provided with any tools listed here.

- ¼" nut driver
- Level
- Screwdriver
- Adjustable wrench
- Tape measure
- Hammer
- Sealant

Check local codes, check existing electrical supply, and read "Ductwork Requirements," and "Electrical Requirements," before purchasing parts.

- UL listed wire nuts
- Replacement orifice (if needed). See "Verify Orifice Size." The correct orifice size may be contained in the replacement orifice package located inside the control box of the outdoor unit. If this package does not contain the correct orifice for your air handler, you must purchase the correct orifice size.

Outdoor System Requirements

The air handler is designed to match, and must be used with, outdoor units as rated. The indoor sections are manufactured with an interchangeable refrigerant metering orifice to provide optimum refrigerant control and system performance with a variety of different capacities of outdoor units.

In some cases, the rating of the outdoor unit may require that the air handler coil assembly orifice be changed to obtain rated performance.

Location Requirements

⚠ WARNING



Explosion Hazard

Keep flammable materials and vapors, such as gasoline, away from air handler.

Place air handler so that heating elements are at least 18 inches (46 cm) above the floor for a garage installation.

Failure to follow these instructions can result in death, explosion, or fire.

NOTE: When the unit is installed in a very humid space and used in cooling applications, excessive sweating may occur on outside of unit. To prevent excessive sweating wrap unit with 1" fiberglass insulation. All openings should be sealed to prevent air leakage that could cause condensate to form inside the cabinet.

- If installed in an unconditioned space, sealant should be applied around the electrical wires, refrigerant tubing, and condensate lines where they enter the cabinet.
- Electrical wires should be sealed on the inside where they exit the conduit opening. Sealant is required to prevent air leakage into and condensate from forming inside the air handler, control box, and on electrical controls.
- The air handler must be installed in such a way as to allow free access to the coil/filter compartment and blower/control compartment.

Installation Clearances

Non-Ducted Return Closet Installation

The air handler can be installed in a closet with a false bottom to form a return air plenum or be installed with a return air plenum under the air handler.

Louvers or return air grilles are field supplied. Local codes may limit application of systems without a ducted return to single-story buildings.

- Install louvers in a closet. Use the “Minimum Filter Requirements Chart” to determine the opening size that will provide the amount of free air you will require. If using louvers or grilles, match the free area rating of the louver or grille to the Minimum Return Air Free Area you determined to be necessary by consulting the “Minimum Filter Requirements Chart.”
 - If the free area is not known, assume a 25% free area for wood or a 75% free area for metal louvers or grilles.
 - If the return air plenum is used, the return air grille should be immediately in front of the opening in the plenum to allow for the free flow of return air.
 - When not installed in front of the opening, there must be adequate clearance around the air handler to allow for the free flow of return air.
-

Installation Configuration Options

For ease of installation, it is best to make any necessary coil configuration changes before setting air handler in place.

- Vertical models only contain 1 drain pan.
 - Multi-Position models contain 2 drain pans.
-

Vertical Installations

Upflow

The air handler must be supported on the bottom only and set on solid floor or field supplied supporting frame. Securely attach the air handler to the floor or supporting frame.

Horizontal Installations

Horizontal installations can be left-hand or right-hand air supply.

Adequate support must be provided to ensure cabinet integrity. Units mounted horizontal should be mounted with a slight angle toward the drain connections to be used so that the drain pan will empty completely without water standing in the pan.

Ensure that there is adequate room to remove service and access panels if installing in the horizontal position.

IMPORTANT:

- This coil is provided with a secondary drain that should be trapped and piped to a location that will give the occupant a visual warning that the primary drain is clogged. See “Install Condensate Drain.”
- When an evaporator coil is installed in an attic or above a finished ceiling, an auxiliary drain pan should be provided under the air handler as specified by most local building codes.
- Extend suction line insulation into the coil cabinet by 2” to prevent moisture from dripping onto the insulation (the rubber grommet may need to be removed)

Conversion from Vertical to Horizontal

An upflow only air handler may be converted to horizontal air discharge by installing a horizontal drain pan kit (see accessories).

An upflow/horizontal air handler may be converted from horizontal left-hand discharge to horizontal right-hand discharge without additional parts.

Suspended Cabinet Installation

NOTE: Air handlers cannot be installed horizontally lying on or suspended from either the front or back of the air handler. It must be positioned with one side parallel to the floor when in the horizontal position.

The suspending means must be field fabricated, and should consist of two “cradles” made by attaching two rods to a length of angle iron or suitable gauge steel.

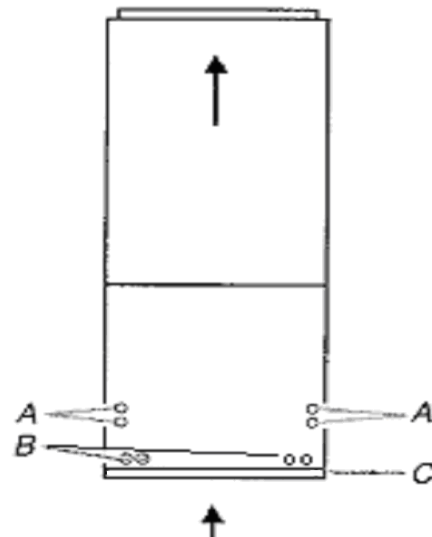

Figure 1. Air Handler in upflow vertical position.

- A. Horizontal left or right-hand drain connections
- B. Upflow drain connections
- C. Bottom/filter frame

Drain Pan Connections

Horizontal installations can be either "Right" or "Left."

For horizontal right installations, a drain pan location change is required. Use drain connections "A" below.

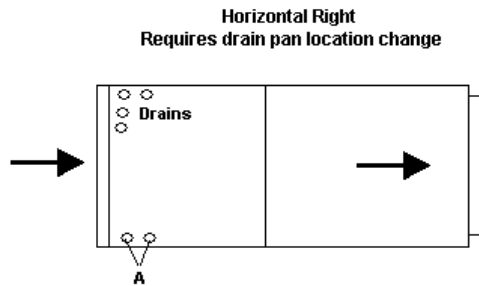

For horizontal left installations, use drain connections marked "A" below.

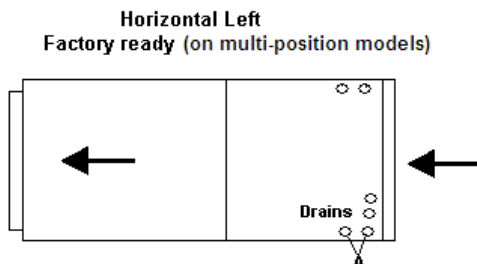

Figure 2. Air Handler in horizontal position.

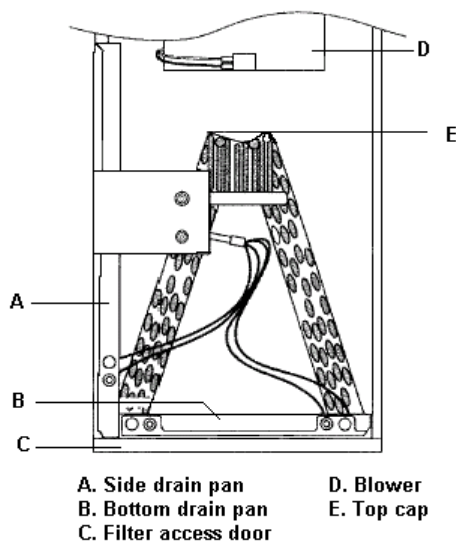

Figure 3. Front view of Air Handler without front access panel.

Follow these steps to modify drain pan for horizontal right configuration.

1. Remove and set aside blower and front access panels.
2. Remove the coil support bracket.
3. Carefully remove coil assembly, bottom drain pan and side drain pan as one assembly from the air handler.

Caution: Take care when removing coil assembly from unit. Installation in this configuration may cause the coil to tip into unit once clear of the cabinet. Support the coil when removing.

4. Move side drain pan to the opposite side.
5. Install modified coil assembly back into air handler in the same orientation as before.
6. Install the coil support bracket on the opposite side of the air handler.

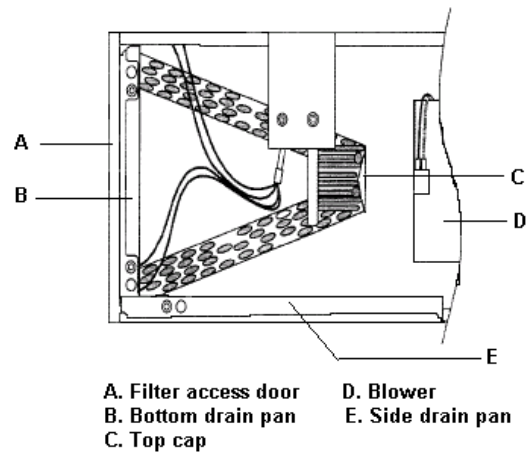



Figure 4. Front view of Air Handler in horizontal position without front access panel after conversion.

7. Determine knockouts required for drain line connections. Knock out and install drain lines.
8. Replace the blower and coil access doors.

Electrical Requirements

⚠ WARNING



Electrical Shock Hazard

Electrically ground electric heater.
Connect ground wire to ground terminal marked "GND."
Use copper wire rated for supply connection.
Correct wire gauge is shown in the chart below.
Failure to follow these instructions can result in death or electrical shock.

Rating Plate Ampacity	AWG
21 - 30	10
31 - 40	8
41 - 60	6

NOTE: Use copper conductors only.

- All field wiring must be done in accordance with National Electrical Code, applicable requirements of UL and local codes, where applicable.
- Electrical wiring, disconnect means and over-current protection are to be supplied by the installer. Refer to the air handler rating plate for maximum over-current protection, minimum circuit Ampacity, as well as operating voltage.
- The power supply must be sized and protected according to the specifications supplied on the product.
- This air handler is factory configured for 240 Volt, single phase, 60 cycles. For 208 Volt applications, see "208 Volt Conversion" in the "Make Electrical Connections" section.
- For optional electric heater applications refer to the instructions provided with the accessory for proper installation.

Ductwork Requirements

- Install the conditioned air plenum, ducts and air filters (not provided) in accordance with NFPA 90B Standard for the Installation of Warm Air Heating and Air-Conditioning Systems (latest edition).
- The air handler is provided with flanges for the connection of the plenum and ducts.
- The air handler is equipped with flanges that can form a filter rack for the installation of the air filter, or the filter may be installed as part of the return air duct system.
- Air filters must be listed as Class 2 furnace air filters.
- Supply and return ductwork must be adequately sized to meet the system's air requirements and static pressure capabilities. Ductwork should be insulated with a minimum of 1" thick insulation with a vapor barrier in conditioned areas and 2" minimum in unconditioned areas.
- Supply plenum should be the same size as the flanged opening provided around the blower outlet and should extend ideally at least 3 ft. from the air handler before turning or branching off plenum into duct runs. The plenum forms an extension of the blower housing and minimizes air expansion losses from the blower.

INSTALLATION INSTRUCTIONS

Inspect Shipment

⚠ WARNING

Excessive Weight Hazard

Use two or more people to move and install air handler.
Failure to do so can result in back or other injury.

All air handlers components are performance tested. Each unit consists of a blower assembly, refrigerant coil and controls, in an insulated, factory-finished enclosure. Knockouts are provided for electrical wiring entrance.

1. Check the unit rating plate to confirm specifications are as ordered.
2. Upon receipt of equipment, carefully inspect it for possible shipping damage. Take special care to examine the unit if the carton is damaged.

If damage is found, it should be noted on the carrier's freight bill. Damage claims should be filed with the carrier immediately. Claims of shortages should be filed with the seller within 5 days.

NOTE: If any damages are discovered and reported to the carrier, do not install the unit because your claim may be denied.

If a filter is to be installed, a filter rack must be formed using factory-supplied flanges as shown in Figure 5.

1. Lay air handler on its back.
2. Pry filter rack tabs.
3. Place air handler in vertical position.

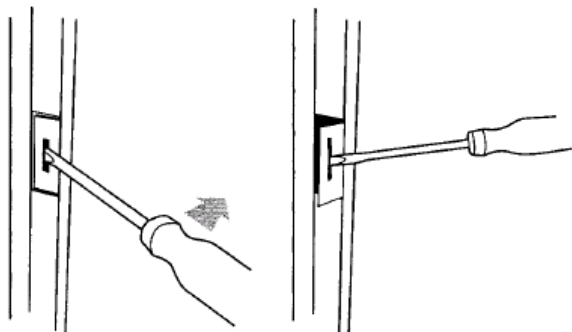

Figure 5. Drawing depicting filter rack tabs being adjusted.

Filter Size Chart

Model	Filter Size
12/18/24	12" X 20"
25/30/36	16" X 20"
31/37/42/48/60	18" X 25"

Install Condensate Drain

The air handler is provided with 3/4" NPT condensate drain connections.

A field fabricated secondary drain pan, with a drain pipe to the outside of the building, is required in all installations over a finished living space or in any area that may be damaged by overflow from the main drain pan. In some localities, local codes may require a secondary drain pan for horizontal installations. For horizontal applications make sure unit is tilted with a 3/4" drop in the horizontal position towards the drain pan to ensure proper condensate drainage. The blower and coil should also be tilted 1/2" from back to front toward the drain line so that the drain pan will empty completely without water standing in pan.

1. Remove the appropriate drain knockouts. See "Drain Pan Connections Section". You may need to remove the indoor coil assembly from the cabinet.
2. Remove any web from inside and threaded drain pan hole to which a drain line is to be connected. Use care when removing the web so as not to damage the coil.
3. Connect primary drain line connection to the primary drain pan connection. The primary drain connection is flush with the bottom of the inside of the pan. Secondary connection is raised above the bottom of the inside of the pan.

4. Secondary drain connections, if used, should be connected to a separate drainage system. Run the secondary drain so the occupant will be able to notice if water is flowing through the secondary drain.
5. Install a 2" trap in both the primary and secondary drain lines as close to the unit as practical. Make sure the top of the trap is below the connection to the drain pan to allow complete drainage of the pan.

NOTE: Horizontal runs must also have an antisiphon air vent (standpipe) installed ahead of the horizontal run. See Figure 6. An extremely long horizontal run may require an oversized drain line to eliminate air trapping.

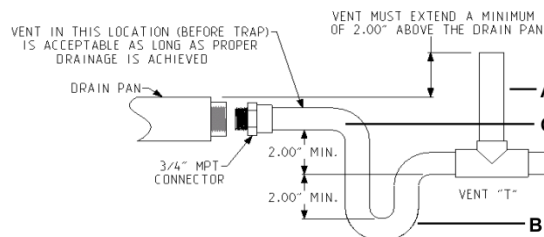

Figure 6. Typical condensate drain connection with A- Antisiphon Air Vent, B- Drain Trap, and C- Drain Line. Secondary drain not shown.

NOTE: Do not operate air handler without a drain trap. The condensate drain is on the negative pressure side of the blower; therefore, air being pulled through the condensate line will prevent positive drainage without a proper trap.

6. Route the drain line to the outside or to an appropriate drain. Drain lines must be installed so they do not block service access to the front of the air handler. A 24" clearance is required for filter, coil, or blower removal and service access.
- NOTE:** Check local codes before connecting the drain line to an existing drainage system.
7. Insulate the drain lines where sweating could cause water damage.

Upon completion of installation, it is the responsibility of the installer to ensure the drain pan(s) is capturing all condensate, and all condensate is draining properly and not getting into duct/system.

1. Pour several quarts of water into drain pan, enough to fill drain trap and line.
2. Check to make sure the drain pan is draining completely, no leaks are found in drain line fittings, and water is draining from the end of the primary drain pan.
3. Correct any leaks found.

Install Ductwork

IMPORTANT:

- Install ductwork in accordance with NFPA 90B and any local codes.
- Connect supply air duct to the flange on top of the air handler. If an isolation connector is used, it must be nonflammable.
- A return air duct system is recommended. If the unit is installed in a confined space or closet, a return connection must be run to a location outside the cabinet.

Verify Orifice Size

NOTE: Some models are equipped with thermo expansion valve and do not require any orifice change.

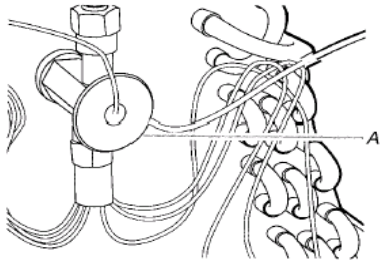

Figure 7. Diagram of Thermo Expansion Valve (Letter A)

Factory Installed Expansion Valves - Sensing bulbs are factory installed and clamped to the suction line. For optimum performance, reattach and insulate the bulb at a 10 to 2 o'clock position outside of the cabinet to the main suction line no more than one foot from the suction line connection.

IMPORTANT: For optimum performance, the piston should be sized to match the recommendation from the outdoor unit manufacturer. Consult the outdoor unit information to determine whether the indoor unit has the correct orifice size.

When changing pistons, use the following procedure:

1. Loosen the hex nut located on liquid line and separate from distributor assembly.

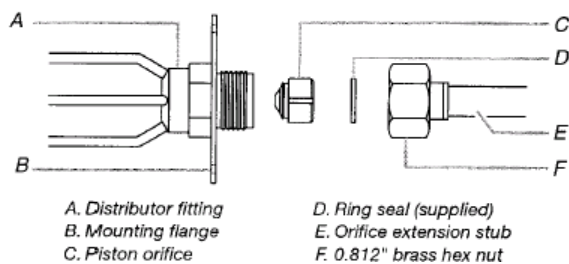

Figure 8. Side view of Piston Orifice

2. Remove the existing piston from inside the distributor assembly.

3. Insert the desired piston into the distributor assembly.
4. Inspect Teflon O-Ring and replace if damaged. Ensure Teflon O-Ring is in place.
5. Re-install hex nut to body and torque to 10 ft-lbs.

Connect Refrigerant Lines

Refrigerant lines must be connected by a licensed, EPA certified refrigerant technician in accordance with established procedures.

IMPORTANT:

- Connecting refrigerant lines must be clean, dehydrated, refrigerant-grade copper lines. Air handler coils should be installed only with specified line sizes for approved system combinations.
- Use care with the refrigerant lines during the installation process. Sharp bends or possible kinking in the lines will cause a restriction.
- Do not remove the caps from the lines or system connection points until connections are ready to be completed.

1. Route the suction and liquid lines from the fittings on the indoor coil to the fittings on the outdoor unit. Run the lines in a direct path, avoiding unnecessary turns and bends.
2. Ensure that the suction line is insulated over the entire exposed length and that both suction and liquid lines are not in direct contact with floors, walls, ductwork, floor joists, or other piping.
3. Connect the suction and liquid line to the evaporator coil.
4. To avoid damaging the rubber grommets in the cabinet while brazing, slide the rubber grommets over the refrigerant lines until they are away from the heat source.
5. Braze with an alloy of silver or copper and phosphorus with a melting point above 1,100°F. **NOTE:** Do not use soft solder.
6. Reinstall the rubber grommets after brazing is finished.
7. Make sure the outdoor air conditioning unit has been put in place according to the Installation Instructions and is connected to the refrigerant lines.

Refrigerant Charging Instructions

When charging in cooling mode, the outdoor temperature should be 60°F or higher. To allow the pressures to stabilize, operate the system a minimum of 10 minutes between adjustments.

TXV – Use the subcooling recommended by the outdoor unit instructions, or use the range of 6°F to 15°F subcooling. If equipped, adjust the TXV to 6°F to 10°F superheat.

Fixed Orifice – Use the superheat recommended by the outdoor unit instructions, or use the superheat table below.

Outdoor Air Temp. (°F)	Nominal Superheat (°F)	Minimum Superheat (°F)
60	31	28
65	28	25
70	25	22
75	22	20
80	20	16
85	16	13
90	13	10
95	10	6
100	8	6
105	6	4
110	5	4
115	5	4

For heat pumps initially charged in the cooling mode, final adjustment in heating mode is acceptable if necessary. When charging heat pumps in the heating mode, refer to the outdoor unit charging instructions.

Electrical Connections – Models without Electric Heat

120 V, 208/240 V Installations – 3 & 5-Speed Motors

⚠ WARNING



Electrical Shock Hazard

Disconnect all power supplies before servicing.

Replace all parts and panels before operating.

Failure to do so can result in death or electrical shock.

1. Disconnect all power supplies.
2. Remove the air handler access panel.
3. Route the field supply wires to the air handler electrical connection box.
4. Using UL listed wire nuts; connect the field supply wires to the air handler, black-to-black and yellow-to-yellow (240V) or white to white (120V), as shown in Figure 9.
5. Connect ground wire to ground terminal marked "GND."
6. Replace the air handler access panel.

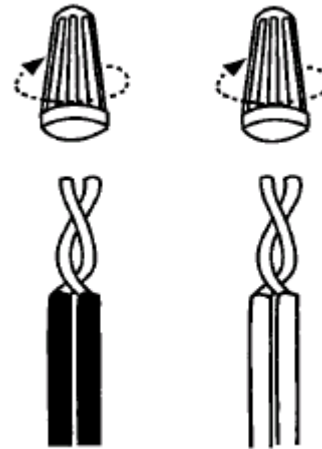

Figure 9. Field and Air Handler Wire Connections.

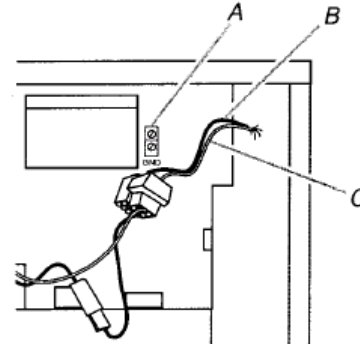

Figure 10. Field and Air Handler Wire Connections. A - Ground Terminal Connection. B - Black to Black Connection C-Yellow-to-Yellow connection.

208 Volt Conversion – 3-Speed Motors Only

1. Disconnect all power supplies.
2. Remove the air handler access panel.
3. Move the 2 connected black transformer leads from the 240 Volt terminals on the transformer to the 208 Volt terminals on the transformer. See "Wiring Diagram – 3-Speed Motor."

Electrical Connections – Models with Electric Heat.

⚠ WARNING



Electrical Shock Hazard
 Disconnect all power supplies before servicing.
 Replace all parts and panels before operating.
 Failure to do so can result in death or electrical shock.

1. Determine the number of circuits needed to supply the heater with electrical power (1 or 2 circuits). See the air handler Accessory Kit label for number of circuits and ratings.
2. Disconnect all power supplies.
3. Knock out the correct number of knockouts (1 or 2), and install UL listed wires and fittings.
4. Connect appropriate size wire to circuit breaker terminals. If circuit breakers are not provided, a terminal block is provided.
5. Connect green ground wire(s) (1 or 2) to ground terminal(s) (1 or 2) marked "GND."
6. Install conduit-opening plugs in any unused openings.
7. Reinstall the air handler blower access panel.
8. Reconnect power
9. Dispose of all remaining parts.

⚠ WARNING



Electrical Shock Hazard
 Electrically ground electric heater.
 Connect ground wire to ground terminal marked "GND."
 Use copper wire rated for supply connection.
 Correct wire gauge is shown in the chart below.
 Failure to follow these instructions can result in death or electrical shock.

Rating Plate Ampacity	AWG
21 - 30	10
31 - 40	8
41 - 60	6

Connect to Circuit Breaker

NOTE: There are 2 ground terminals marked "GND" shown in Figure 11. There may be 1, 2, or 3 ground terminals depending on the number of circuit breakers.

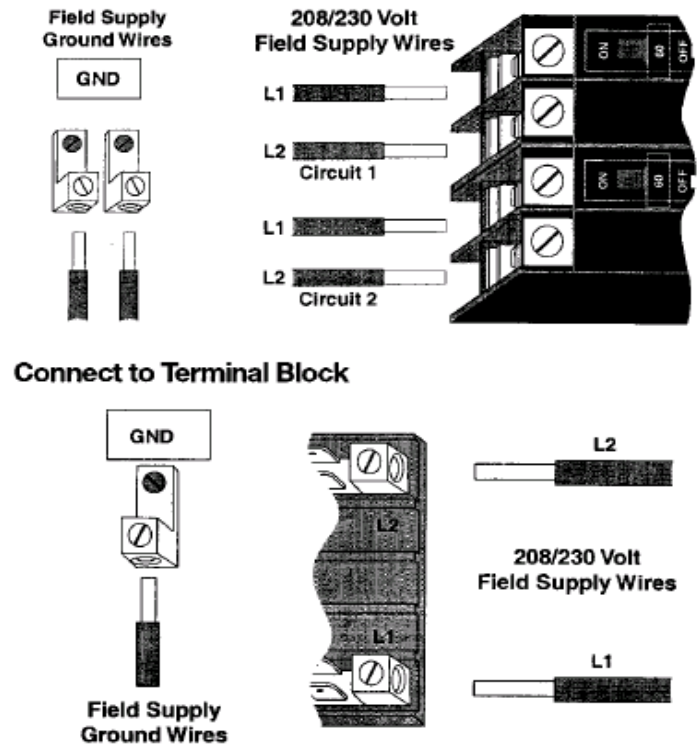
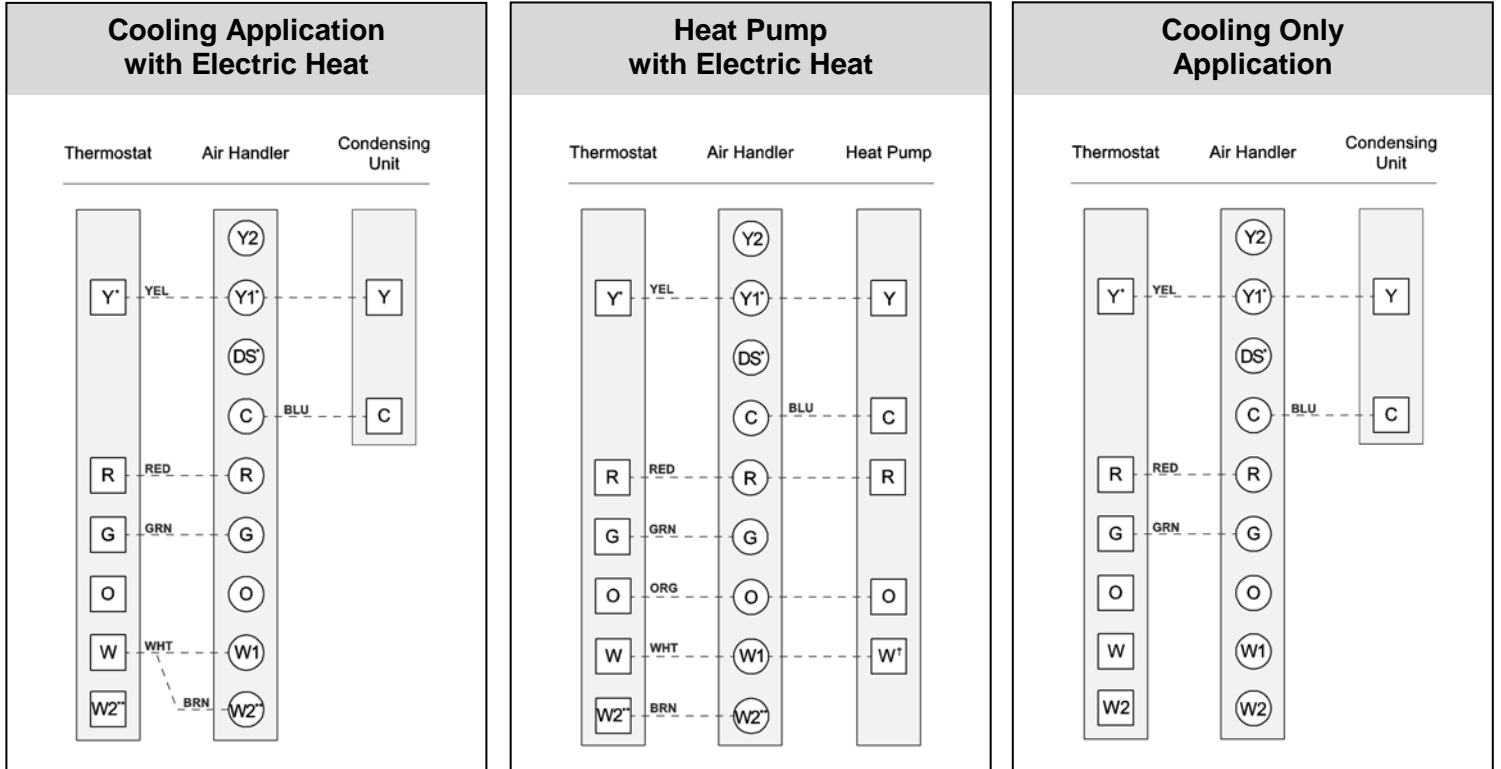

Figure 11. Air Handler Supply Voltage Wire Connections.

Typical Single Stage Thermostat Connections: 5-speed High Efficiency ECM Motor



- † For high static system, jumper "Y1" & "DS" at air handler terminal block
- ** For single stage heat, jumper "W1" & "W2" at air handler terminal block
- † The "W" connection on heat pump could also be referred to as "X2"

Typical 2-Stage Thermostat Connections: 5-speed High Efficiency ECM Motor

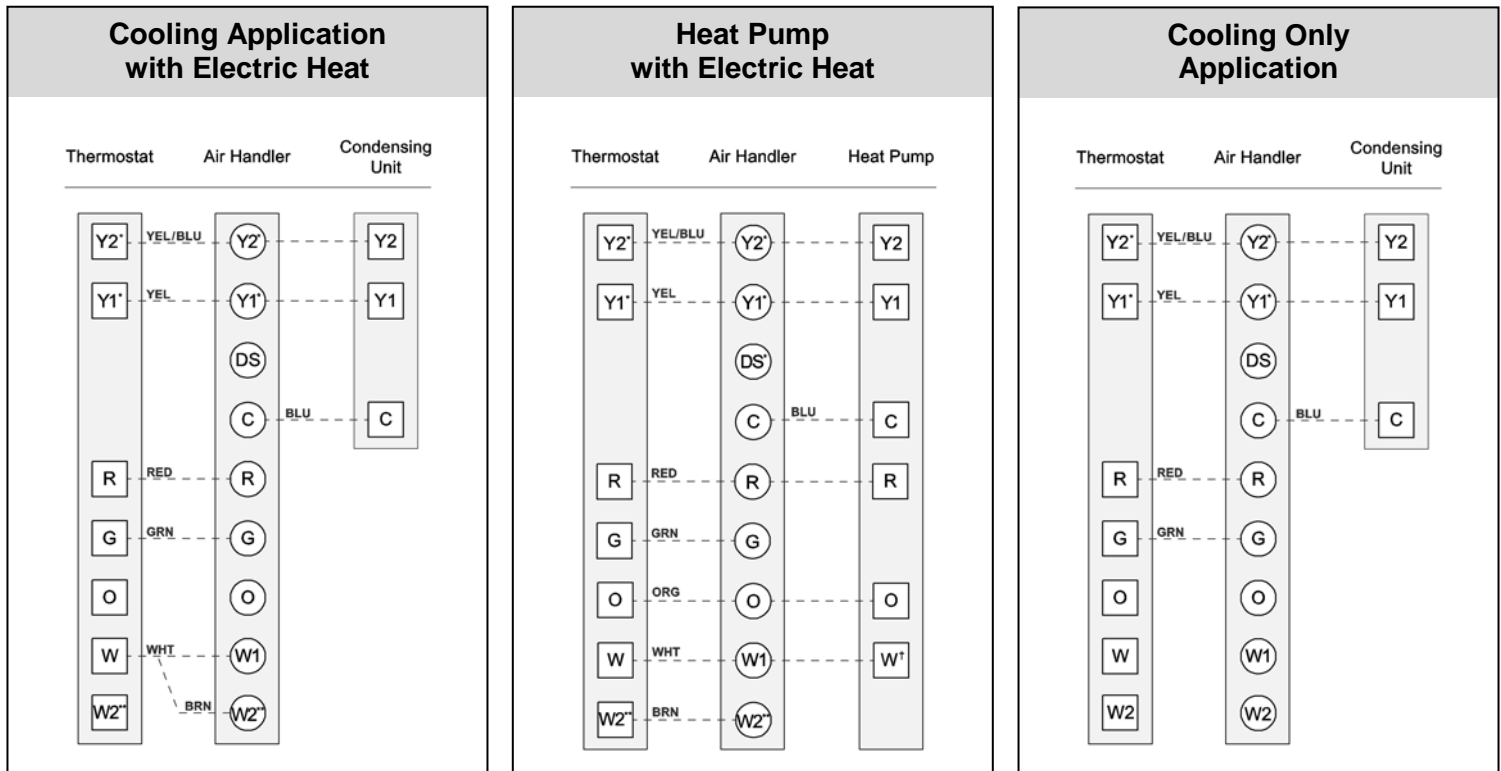

- For typical 2-stage operation, move motor tap 3 (YEL) to Y2, and move motor tap 2 (BRN) to Y1.
- † For high static system and other blower speed changes, see page 14.
- ** For single stage heat, jumper "W1" & "W2" at air handler terminal block
- † The "W" connection on heat pump could also be referred to as "X2"

Wiring Diagram – 5-Speed High Efficiency ECM Motor

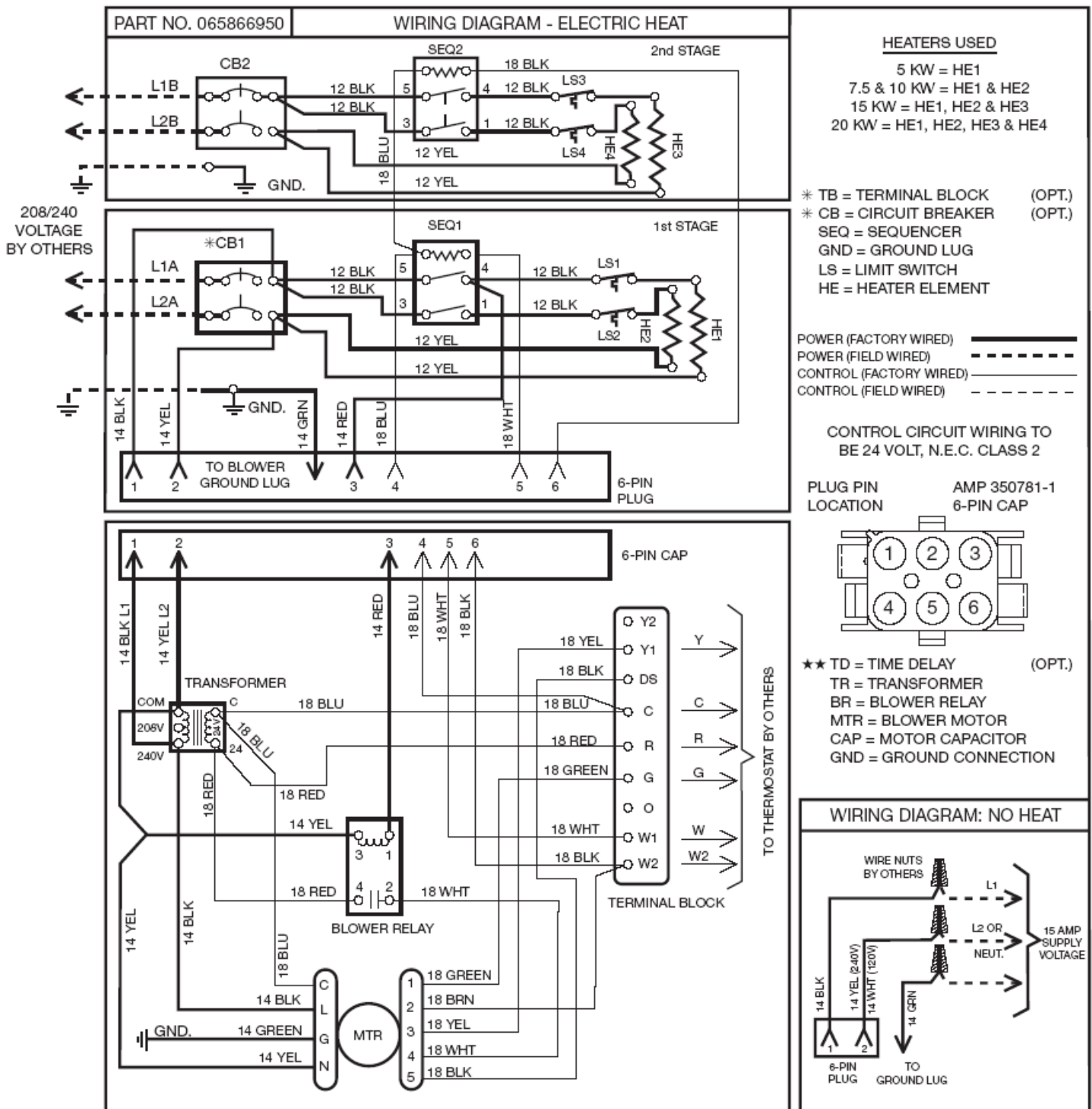

Typical Single Stage Thermostat Connections: 3-speed PSC Motor

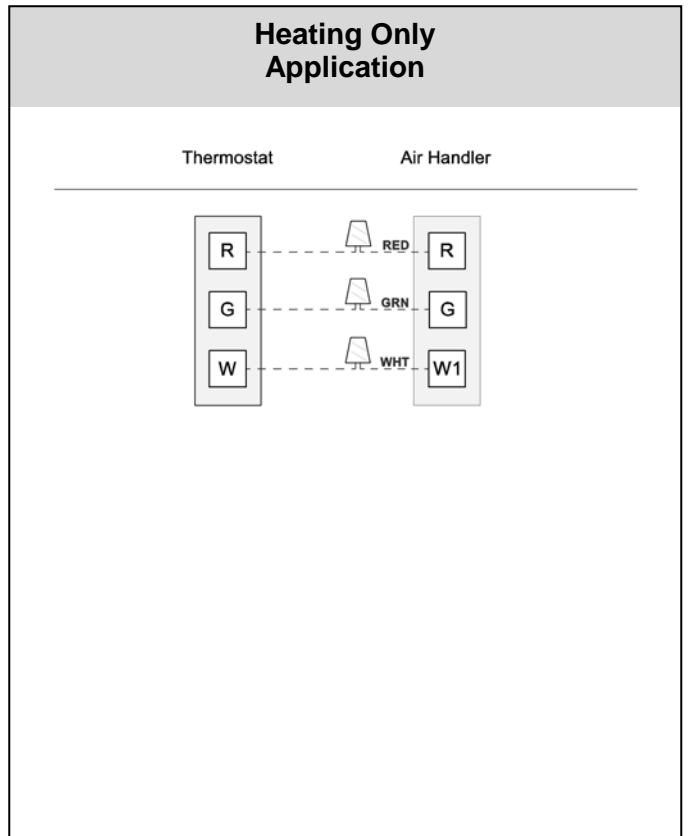
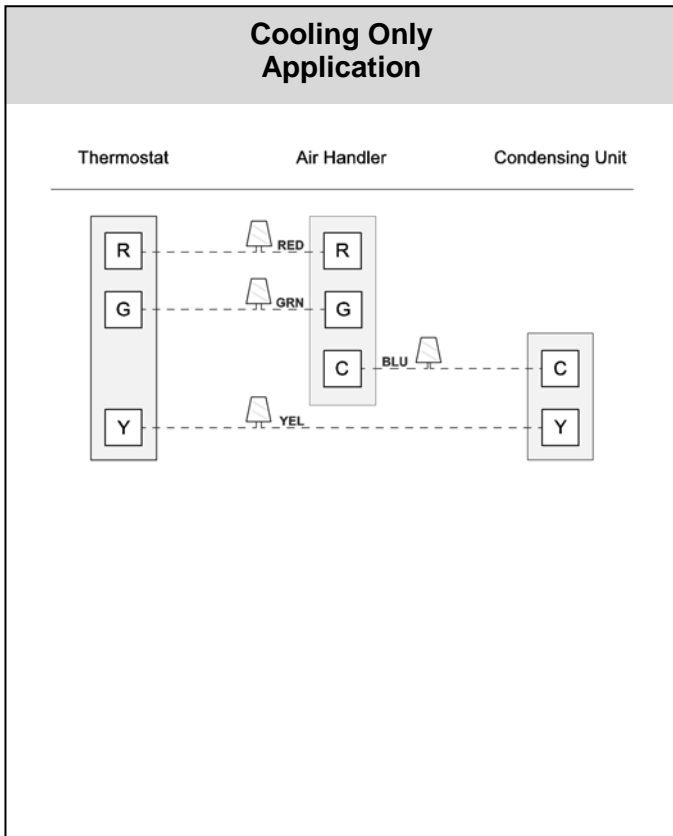
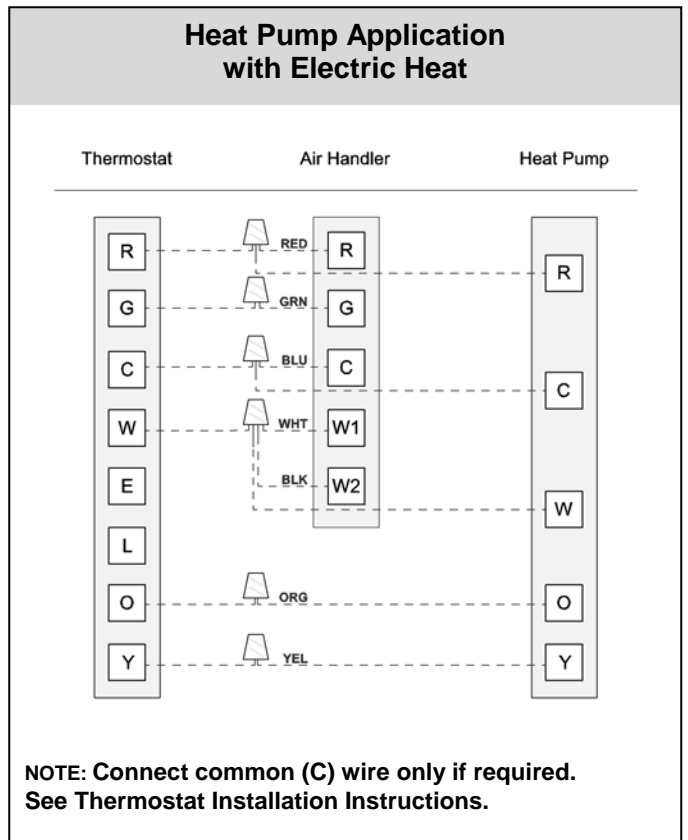
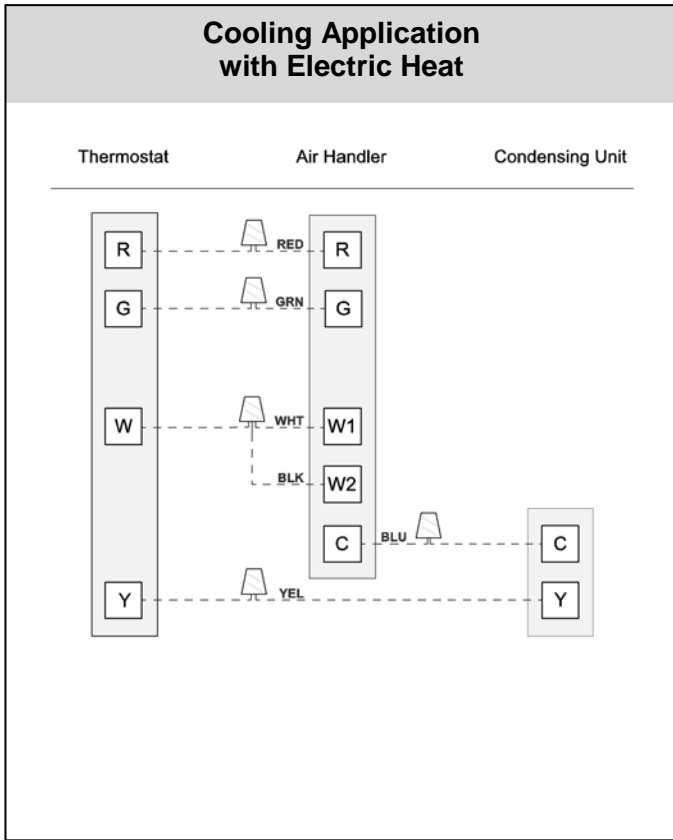

Wiring Diagram – 3-Speed Motor

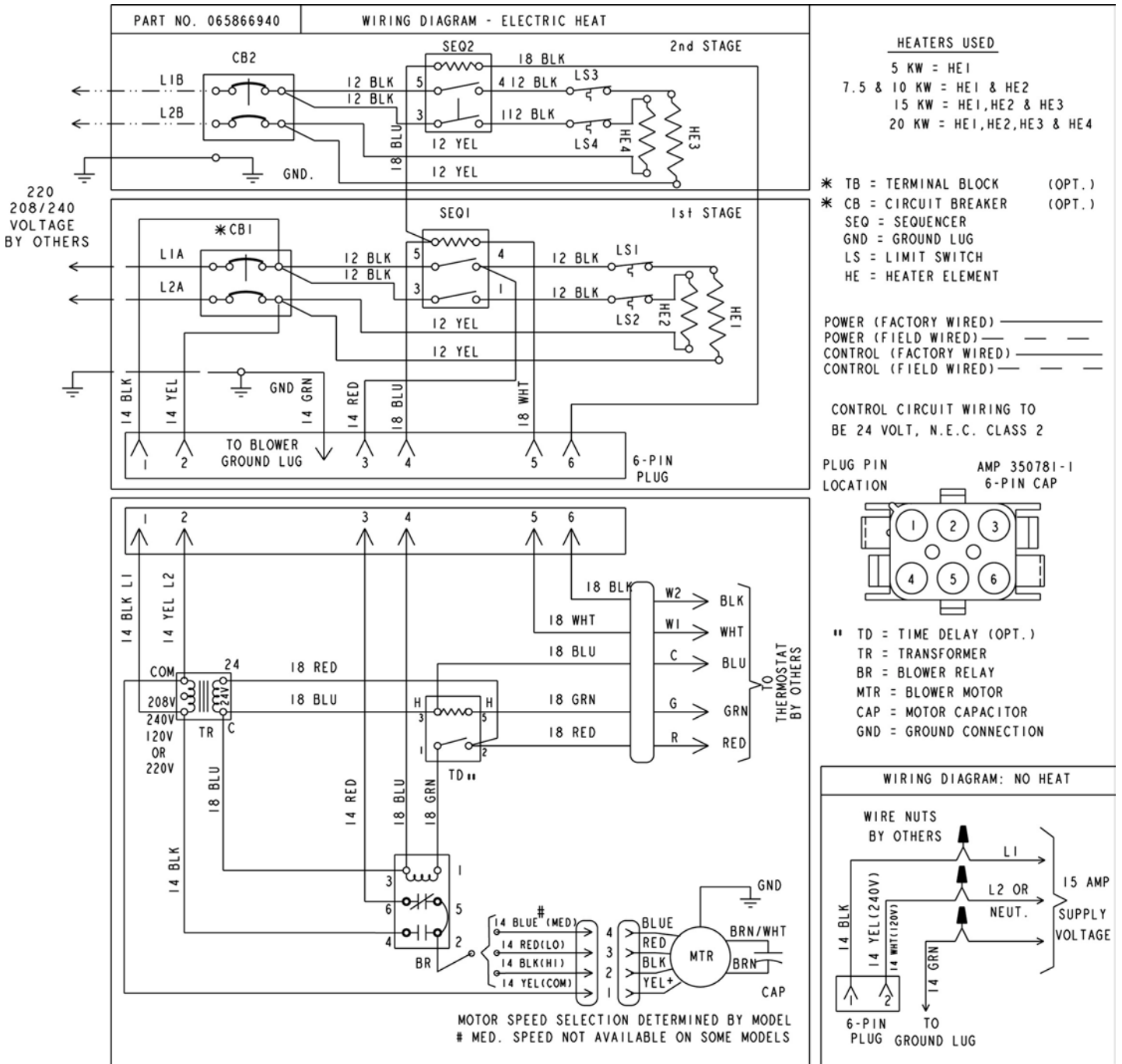

Check Blower Operation

1. Set thermostat to FAN ON.
2. The indoor blower should come on.

Check Electric Heater (if used)

1. Set thermostat to call for auxiliary heat (approximately 5°F above ambient temperature). The indoor blower and auxiliary heat should come on together. Allow a minimum of three minutes for all sequencers to cycle on.
2. Set the thermostat so it does not call for heat. Allow up to five minutes for all sequencers to cycle off.

Check Airflow

Cooling blower speed

- For proper cooling operation, the airflow through the indoor coil should be between 350 and 450 CFM per ton of cooling capacity (350 - 450 CFM per 12,000 BTU/HR) based on the rating of the outdoor unit.
- The cooling blower speed is factory configured to provide correct airflow for an outdoor unit that matches the maximum cooling capacity rating of the air handler.
- If the outdoor unit is smaller than the maximum cooling capacity rating for the air handler, the cooling blower speed may need to be changed. Refer to “Blower Performance Chart.”

IMPORTANT: The cooling blower speed must be set to provide a minimum of 350 CFM airflow per ton (12,000 BTU/HR) of outdoor cooling capacity.

⚠ WARNING



Electrical Shock Hazard

Disconnect all power supplies before servicing.
Replace all parts and panels before operating.
Failure to do so can result in death or electrical shock.

To change blower speed for 3-Speed Motor: (Refer to “Wiring Diagram – 3-Speed Motor.”)

1. Disconnect all power supplies.
2. Remove the air handler access panel.
3. Locate pin number 2 on the blower relay. Two black wires are connected to this terminal pin. One wire connects to pin number 5 on the blower relay; one connects to an inline splice connecting to a blue wire.
4. Remove the wire going to the 4-pin blower motor connector from the splice.
5. Connect the blower lead (Red [LO], Blue [MED], Black [HI]) onto the splice from the 4-pin blower motor connector.
NOTE: Unused blower speeds are shipped from the factory covered with a plastic cap. Remove this cap from the new blower speed terminal and replace it over the factory set blower terminal.
6. Replace all panels.
7. Reconnect power.

To change blower speed for 5-Speed High Efficiency ECM Motor: (Refer to “Wiring Diagram – 5-Speed High Efficiency ECM Motor.”)

1. Disconnect all power supplies.
2. Remove the air handler access panel.
3. Locate low voltage terminal block on air handler.
4. Reduced airflow single stage installation (1/2 ton lower airflow):
 - a. Move motor tap 2 (BRN) to Y1.
 - b. Move motor tap 3 (YEL) to W2.
5. High static single stage installation:
 - a. Jumper terminals Y1 and DS
6. Typical 2-stage installation:
 - a. Move motor tap 3 (YEL) to Y2 terminal.
 - b. Move motor tap 2 (BRN) to Y1 terminal.
7. Reduced airflow 2-stage installation (1/2 ton lower airflow):
 - a. Move motor tap 2 (BRN) to Y2 terminal.
 - b. Move motor tap 1 (GRN) to Y1 terminal.
 - c. Move motor tap 3 (YEL) to G terminal.
 - d. Note: A call for “fan on” will provide higher CFM than normal operation.
8. High static 2-stage installation:
 - a. Move motor tap 5 (BLK) to Y2 terminal.
 - b. Move motor tap 3 (YEL) to DS terminal.
 - c. Move motor tap 2 (BRN) to Y1 terminal.
9. Replace all panels.
10. Reconnect power.

Blower Performance – 3-Speed PSC Motor

- All data is given while air handler is operating with a dry coil and air filter installed.
- Speeds marked ***bold with asterisk** are the factory speed settings for both heating and cooling.
- Heating speeds should not be reduced below factory setting.
- Different speeds can be set for cooling mode; see installation instructions for changing cooling speeds.

208/240 Volt 3-Speed PSC Motor

		Airflow (CFM) vs. External Static Pressure (inches W.C.)				
Size	Speed	0.10	0.20	0.30	0.40	0.50
18	Low	505	499	487	434	397
	*Med	653	634	625	600	512
	High	891	853	812	778	733
24	Low	663	624	583	578	562
	*Med	902	864	822	792	744
	High	1159	1097	1031	960	893
25	*Low	867	839	803	780	733
	Med	1044	1015	991	941	889
	High	1260	1234	1200	1149	1098
30	Low	867	839	803	780	733
	*Med	1044	1015	991	941	889
	High	1260	1234	1200	1149	1098
31	*Low	1143	1112	1081	1047	1015
	Med	1268	1233	1186	1165	1133
	High	1415	1390	1352	1314	1260
36	Low	1143	1112	1081	1047	1015
	*Med	1268	1233	1186	1165	1133
	High	1415	1390	1352	1314	1260
37	*Low	1318	1299	1270	1210	1147
	Med	1444	1409	1374	1294	1220
	High	1712	1645	1544	1453	1328
42	Low	1318	1299	1270	1210	1147
	*Med	1444	1409	1374	1294	1220
	High	1712	1645	1544	1453	1328
48	*Low	1764	1709	1652	1563	1418
	Med	1984	1884	1780	1683	1509
	High	2031	1959	1832	1725	1617
60	Low	1764	1709	1652	1563	1418
	Med	1984	1884	1780	1683	1509
	*High	2031	1959	1832	1725	1617

120 Volt 3-Speed PSC Motor

		Airflow (CFM) vs. External Static Pressure (inches W.C.)				
Size	Speed	0.10	0.20	0.30	0.40	0.50
18	Low	431	424	425	403	385
	*Med	645	645	645	641	597
	High	804	804	804	793	765
24	Low	530	525	519	507	483
	*Med	925	915	875	823	736
	High	1189	1110	1016	917	826
25	*Low	998	956	905	844	770
	Med	1045	1004	962	871	785
	High	1089	1036	980	905	826
30	Low	998	956	905	844	770
	*Med	1045	1004	962	871	785
	High	1089	1036	980	905	826
31	*Low	945	930	912	869	793
	Med	1150	1145	1123	1166	1004
	High	1291	1291	1285	1277	1200
36	Low	945	930	912	869	793
	*Med	1150	1145	1123	1166	1004
	High	1291	1291	1285	1277	1200
42	*Low	1393	1378	1366	1246	1167
	Med	1603	1592	1575	1540	1443
	High	1811	1811	1805	1744	1674
48	Low	1393	1378	1366	1246	1167
	*Med	1603	1592	1575	1540	1443
	High	1811	1811	1805	1744	1674
60	Low	1583	1583	1583	1567	1551
	*Med	1972	1972	1968	1882	1819
	High	2169	2146	2096	2004	1908

Blower Performance – 5-Speed High Efficiency ECM Motor

CFM @ ESP. – in. W. C.

- All data is given while air handler is operating with a dry coil and air filter installed.
- Speeds marked ***bold with asterisk** are the factory speed settings for both heating and cooling.
- Heating speeds should not be reduced below factory setting.
- Different speeds can be set for cooling mode; see installation instructions for changing cooling speeds.

		Airflow (CFM) vs. External Static Pressure (inches W.C.)							
Size	Tap	0.10	0.20	0.30	0.35	0.40	0.45	0.50	0.60
18	1	492	448	393	361	361	333	307	273
	2	513	471	420	414	384	357	325	318
	*3	667	641	615	605	596	577	567	560
	4	705	673	665	648	630	621	603	590
	5	721	689	673	656	639	629	612	590
24, 25	1	732	627	590	581	571	545	536	525
	2	671	634	594	578	573	546	493	480
	*3	892	859	832	828	818	797	790	775
	4	911	866	839	832	825	818	804	760
	5	924	886	846	832	825	818	797	780
30, 31	1	871	830	778	722	671	635	625	586
	2	906	859	809	779	715	689	654	635
	*3	1085	1070	1048	1036	1024	1001	989	975
	4	1125	1103	1087	1059	1047	1024	1012	983
	5	1176	1146	1114	1098	1081	1059	1047	1029
36, 37	1	882	887	826	804	766	760	755	695
	2	1082	1037	1025	1002	990	959	921	881
	*3	1270	1250	1238	1228	1214	1189	1179	1162
	4	1290	1275	1265	1246	1236	1227	1212	1172
	5	1335	1315	1301	1287	1278	1259	1240	1225
42	1	1008	907	861	832	803	772	717	671
	2	1292	1243	1202	1192	1171	1149	1127	1070
	*3	1447	1430	1404	1377	1359	1340	1322	1283
	4	1534	1502	1476	1459	1433	1416	1398	1362
	5	1559	1519	1502	1477	1460	1434	1417	1381
48	1	1585	1494	1320	1252	1210	1151	1120	1088
	2	1510	1463	1414	1389	1363	1324	1256	1228
	*3	1675	1633	1579	1556	1545	1510	1487	1451
	4	1737	1697	1655	1633	1612	1590	1568	1545
	5	1781	1731	1679	1658	1637	1615	1593	1571
60	1	1394	1342	1288	1251	1172	1109	1077	1025
	2	1722	1666	1623	1594	1564	1534	1518	1471
	*3	2083	2048	2013	1990	1972	1947	1929	1885
	4	2179	2135	2101	2079	2056	2039	2021	1937
	5	2209	2166	2122	2101	2057	2058	2047	1956

Sequence of Operation

Application: Cooling (cooling only or heat pump)

When the thermostat calls for cooling, the circuit between R and G is completed, and the blower relay is energized. The Normally Open contacts close, causing the indoor blower motor to operate. The circuit between R and Y is also completed; this circuit closes the contractor in the outdoor fan motor. Circuit R and O energizes the reversing valve, switching it to the cooling position. (The reversing valve remains energized as long as selector switch is on the COOL position.)

Application: Heating (electric heat only)

When the thermostat calls for heat, the circuit between R and W is completed, and the heater sequencer is energized. A time delay follows before the heating elements and the indoor blower motor comes on. Units with a second heat sequencer can be connected with the first sequencer to W on the thermostat sub base or connected to a second stage on the sub base.

Application: Heating (heat pump)

When the thermostat calls for heat, the circuits between R - Y and R - G are completed. Circuit R-Y energizes the contactor starting the outdoor fan motor and the compressor. Circuit R - G energizes the blower relay starting the indoor blower motor. If the room temperature should continue to fall, the second stage heat room thermostat completes the circuit between R - W1. Circuit R - W1 energizes a heat sequencer. The completed circuit will energize supplemental electric heat. Units with a second heater sequencer can be connected with the first sequencer to W1 on the thermostat or connected to a second heating stage W2 on the thermostat sub base.

Application: Emergency Heat (heating heat pump)

If selector switch on thermostat is set to the emergency heat position, the heat pump will be locked out of the heating circuit, and all heating will be electric heat (if applicable). A jumper is necessary so that the electric heat control will transfer to the first stage heat on the thermostat. This will allow the indoor blower to cycle on and off with the electric heat when the fan switch is in the AUTO position.

Air Handler Maintenance

At the beginning of each heating season the unit should be serviced by a qualified installer or servicing agency.

Assistance or Service

If you need further assistance, you may contact us at the address below with any questions or concerns. Please include a daytime phone number in your correspondence.

Advanced Distributor Products
1995 Air Industrial Park Road
Grenada, MS 38901
www.adpnow.com



Air Handler Limited Warranty – Standard 5 Year

(Applies only to product installed within the United States or Canada)

Term of Standard Warranty: Advanced Distributor Products (ADP) warrants that products sold shall be of merchantable quality, free of defects in material and workmanship, under normal use and service, for a period of five (5) years from the date of installation, **not** to exceed six (6) years from the date of manufacture. Use of this product other than in a residential application will limit the warranted term to a period of (1) year from the date of installation, not to exceed two (2) years from the date of manufacture.

Warranty Procedure: Warranty parts should be replaced by a qualified local contractor or dealer and will require the following information: model number, serial number, date of installation and an accurate description of the problem. Contractor or dealer will contact a local ADP distributor for replacement parts.

Replacement Parts: If, during the term of this warranty, a warranted part fails, ADP will either provide a replacement part free of charge, or may at its option, grant a credit for the original purchase price of the defective article to a distributor of ADP products. ADP may require the return of a defective article for factory inspection to verify and/or determine the root cause of the failure. Covered components include all parts of this unit except for the following **excluded components**, which are not covered by this warranty: cabinet, cabinet pieces, wiring and wiring harnesses.

Care of Equipment: For this warranty to apply, ADP product must be properly installed, operated, and maintained in accordance with the installation, operation and maintenance instructions provided with each unit. Unauthorized alteration of ADP product may void this warranty.

Conditions of Warranty: Replacement parts furnished under this warranty will be warranted for the balance of the original warranty term of the unit and will not serve to extend the original term. This warranty is void if the ADP product is removed from the original installation site. This warranty does not apply to damage caused by shipping, misuse, mishandling or damage caused by floods, winds, fires, lightning, or exposure to corrosive elements/environments (such as salt, chlorine, fluorine or other damaging chemicals).

Limitations of Warranty: The costs of refrigerant, refrigerant reclamation, miscellaneous material and labor charges for diagnostics, servicing or replacing parts are not covered. ADP shall have no liability for expenses incurred for repairs without prior, written authorization from ADP. No purchaser, distributor, dealer, representative, agent, person, firm or corporation has authority to alter, add to or modify this warranty, either orally or in writing.

No Other Warranties: ADP makes no warranty, express or implied, of fitness for any particular purpose, or of any other nature whatsoever, with respect to products manufactured or sold by ADP hereunder, except as specifically set forth above and on the face hereof. Any implied warranty of merchantability or fitness for a particular purpose on this product is limited in duration to the duration of this warranty. Some states and provinces do not allow limitations on how an implied warranty lasts, so the above limitation may not apply to you. It is expressly understood and agreed that ADP shall not be liable to buyer, or any customer of buyer, for direct or indirect, special, incidental, consequential or penal damages, or for any expenses incurred by reason of the use or misuse by buyer or third parties of said products. To the extent said products may be considered "consumer products", as defined in Sec. 101 of the Magnuson-Moss Warranty-Federal Trade Commission Improvement Act, ADP makes no warranty of any kind, express or implied, to "consumers," except as specifically set forth above on the face hereof. The foregoing is in lieu of all other warranties, express or implied, notwithstanding the provisions of the Uniform Commercial Code, the Magnuson-Moss Warranty-Federal Trade Commission Improvement Act, or any other statutory or common law, federal or state.

2175 West Park Place Boulevard
Stone Mountain, Georgia 30087
www.adpnow.com

REV 090908





Advanced Distributor Products[®]

Solutions for Your needs

2175 West Park Place Boulevard
Stone Mountain, GA 30087
www.adpnow.com