

MotorPro[®] Training RESCUE[®] Select

“The OEM ECM Replacement Blower Motor”



ECM Motors

- The designation ECM is usually reserved for smaller variable speed motors that operate from a single-phase power source and have the electronic controller mounted in or on the motor
- Electronically commutated motors can have other features that also may be used in addition to ECM in their name

- A permanent magnet rotor
- Some are made to run directly from a DC power source.
- Others are made to run from an AC power source, but they rectify the AC to DC in their controllers before it is pulsed or commutated



ECM Motors

- Power is pulsed on and off electronically with semi-conductor devices, sometimes called electronic switches or transistors
- The pulsed signals power three or more circuits or coil groups within the motor
- By varying the timing and duration of pulses, the electronic controller can accomplish speed control and maintain high torque at start and over a broad speed range



Nidec's Advanced ECM Design

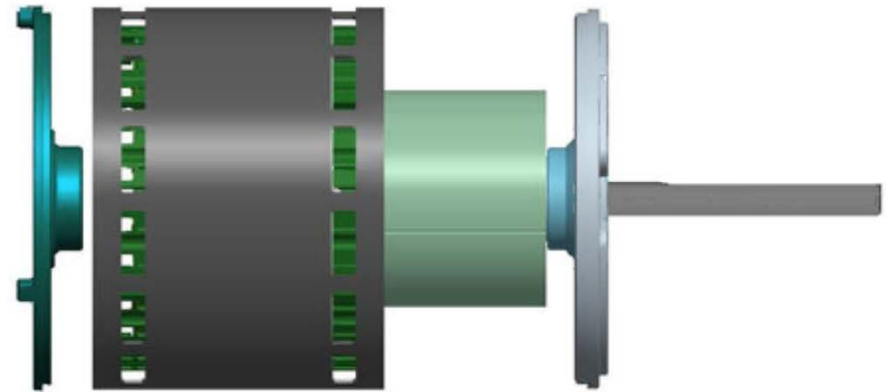
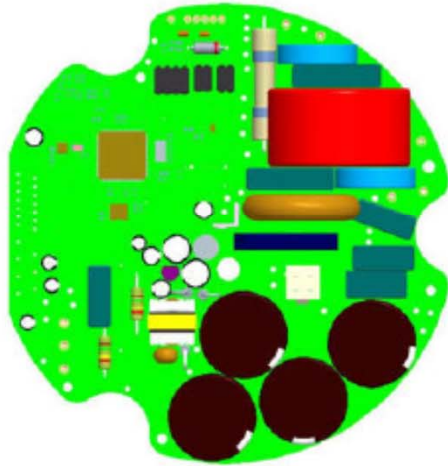

Electronic Control Module

- Sensorless, Sine Wave Control
- Thermal/Power Limit Software Protection
- Smooth Starting

Brushless Permanent Magnet Motor

- 3 Phase Chain Winding Design
- 12 Slot 10 Pole Motor Configuration
- Ferrite Magnet Rotor
- Ball Bearing



ECM Motor Technologies

There are three main ECM motor types

- Constant Torque
 - Constant CFM
 - Constant Speed
- **Constant CFM** motors react to system static pressure changes by adjusting motor RPM up or down to maintain system design airflow performance
 - **Constant Torque** motors react to system static pressure changes by adjusting motor RPM up or down to maintain a pre-programmed torque setting for each speed tap
 - **Constant Speed** motors do not react to system static pressure changes, continue to run at the pre-programmed RPM, and are not commonly found in indoor blower applications

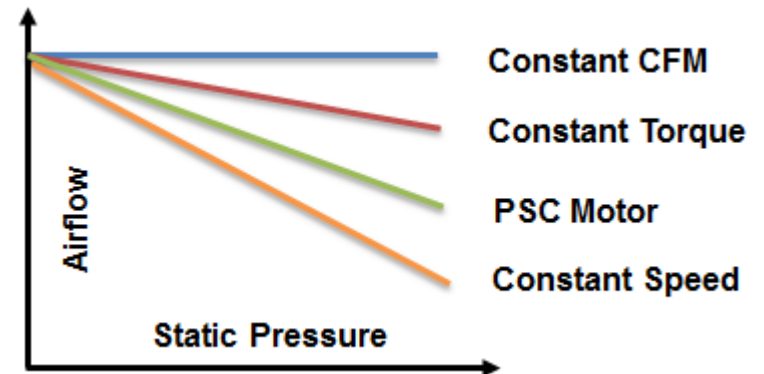

ECM Technologies



| | SelectTech® & X13®* | 16x4w & ECM 2.3 | PerfectSpeed® & ECM 3.0 |
|------------------------|------------------------------------|---|------------------------------------|
| Constant CFM | | ✓ | ✓ |
| Constant Torque | ✓ | ✓ | ✓ |
| Constant Speed | | ✓ | ✓ |
| Control Method | (2-5) programmable Speed Taps | Non-communicating 16 Pin 24v Analog & PWM | 2- Way Serial Communication & PWM |

Note: SelectTech and PerfectSpeed are trademarks of Nidec Motor Corporation

* All marks shown within this document are properties of their respective owners.



ECM Technologies



| | SelecTech® & X13®* | 16x4w & ECM 2.3 | PerfectSpeed® & ECM 3.0 |
|-----------------|-------------------------------|---|-----------------------------------|
| Constant CFM | | ✓ | ✓ |
| Constant Torque | ✓ | ✓ | ✓ |
| Constant Speed | | ✓ | ✓ |
| Control Method | (2-5) programmable Speed Taps | Non-communicating 16 Pin 24v Analog & PWM | 2- Way Serial Communication & PWM |

- RESCUE® Select replaces U.S. MOTORS® SelecTech® and the Regal™* X13 motors.
- It does **NOT** replace the U.S. MOTORS 16x4w and PerfectSpeed® or the Regal™* ECM 2.3 and ECM 3.0

* All marks shown within this document are properties of their respective owners.



How to Identify an X13[®]*

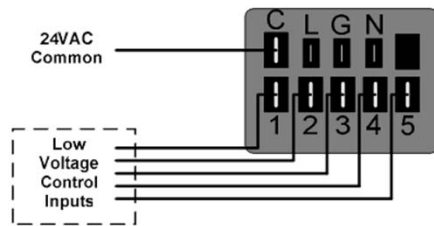

- The X13[®]* motor is a different body
- It is typically referred to as a “one piece” because controls are internal
- Has a unique connector with 5 programmable speed/torque taps
- The X13[®]* trademark is typically found on motor nameplate
- **Primary Applications**
 - Air Handlers #1
 - Heat Pumps #2
 - Furnaces #3
 - Primarily 208-230V
 - 115V volume increasing

* All marks shown within this document are properties of their respective owners.



The ECM Aftermarket Motor That Replaces OEM Constant Torque Blower Motors!

- Replaces SelecTech[®] and X13^{®*} constant torque ECM motors
 - Do not have to purchase the OEM ECM motor from the OEM
 - Programmed at the point of sale to meet the performance of the OEM ECM motor
 - Replace X13 motors from any brand of equipment
- 2 year warranty from time of programming
 - 6000V surge protection!
 - Almost double the protection of most OEM ECM motors
 - Fully potted electric module for superior moisture protection
 - Warranty can be tracked by serial number on motor and is stored in web tool database
- Wires to the OEM equipment using the OEM equipment's existing connections
 - No modifications needed to install!
 - Can be mounted using existing OEM belly band mounting system
 - Kits available for mounting adaption for flex and rigid mounting systems



A Drop In Replacement for the X13^{®*}



Constant Torque Technology

X13^{®*}



- 1
- 2
- 3
- 4
- 5

RESCUE[®] Select



- 1
- 2
- 3
- 4
- 5



RESCUE[®] Select

- 6 “unprogrammed” motor ratings may be used to replace hundreds of OEM motors
 - HP ranges from 1/3 HP to 1 HP
 - 115 & 208-230 Volt
- Profiles (1500+ ratings)
 - New ratings continually being added to the programming database
 - Loading ratings from all equipment manufactures
 - Email notification sent to us if an OEM part number is not in database



Air Conditioning & Heating



No affiliation between the owners of the marks shown on this page and Nidec Motor Corporation is intended or to be construed. All marks shown are the property of their respective owners.



Construction: OEM vs. RESCUE® Select

- RESCUE® Select is a 2 piece motor



Construction: OEM vs. RESCUE® Select

The RESCUE® Select motor is slightly longer than some of the other OEM motors that it replaces

| RESCUE® Select | | X13®* | |
|----------------|--------|------------|--------|
| Horsepower | Length | Horsepower | Length |
| 1/3 | 6.25 | 1/3 | 5.25 |
| 1/2 | 6.25 | 1/2 | 5.75 |
| 3/4 | 6.75 | 3/4 | 6.5 |
| 1 | 7.25 | 1 | 7.25 |



Construction: OEM vs. RESCUE® Select

- The RESCUE Select motor is slightly longer than some of the other OEM motors that it replaces
- Since the belly band is able to be positioned directly next to the RESCUE Select motor's module, the difference in length for mounting purposes is only ½”.
- This additional length should not create any issues with the RESCUE Select motor being able to fit in the blower equipment.

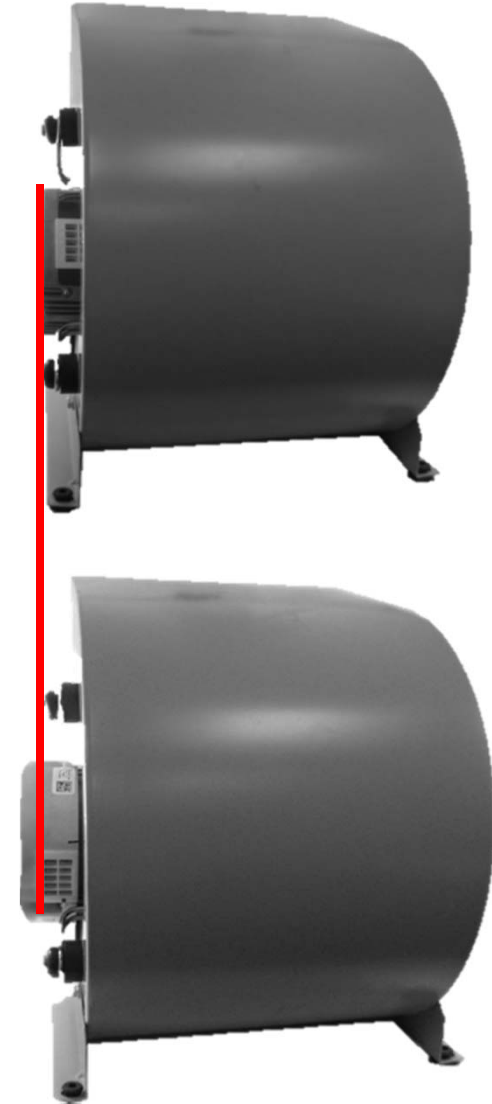

Mounting

- Most OEM ECM motors use a belly band mounting system
 - The RESCUE[®] Select motor can use the original belly band mounting system
- Belly band kits are available
- Use Kits 17, 23, 24, 29, 39 & 44



Kit 17 &
23



Kit
39



Kit 24 &
29



Kit 44





Summary

You should now:

- Understand the difference between the various ECM motor technologies.
- See the key features and benefits of the RESCUE® Select motor.
- Recognize which EC motors the RESCUE Select motor replaces.

Thank You !

